

T B 6 5 2 5 F

CYLINDER AND LOADING MOTOR CONTROLLER IC FOR VTR MOVIES

The TB6525F is a single-chip IC for VTR movie cylinder motor controllers and loading motor controllers.

The cylinder area is a soft-switching pre-driver based on a 3-phase full-wave sensorless drive and 180 degree trapezoidal wave commutation control.

The loading area is a pre-driver for driving the bridge driver, and is equipped with a tape top/tape end sensor, a reel FG amplifier, and a current limiter circuit.

FEATURES

- Operating power voltage: $V_{CC}(\text{opr.}) = 2.7$ to 5.5 V

<Cylinder area>

- Built-in FG amplifier and PG amplifier
- Torque command: Analog output with PWM signal input (built-in integral amplifier)
- Detects the upper V_{CE} and outputs the analog voltage used by the external SW regulator.
- Built-in current limiter: Output current detection with feedback resistance.
- Built-in short-circuit protection function.

<Loading area>

- Four modes: Forward, reverse, stop and break.
- Built-in current limiter:
Output current detection with feedback resistance (equipped with a limiter status output pin).
- Built-in tape top and tape end detection function.
- Two built-in reel FG amplifiers.
- Built-in short-circuit protection function.

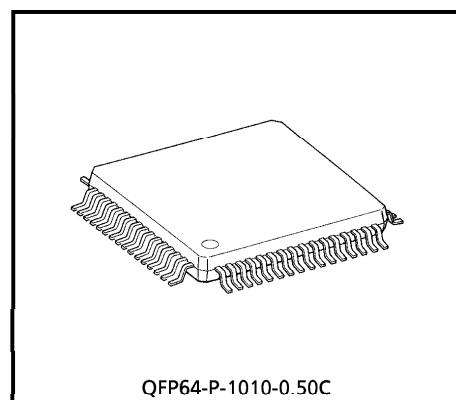

Weight : 0.48 g (Typ.)

980910EBA1

- TOSHIBA is continually working to improve the quality and the reliability of its products. Nevertheless, semiconductor devices in general can malfunction or fail due to their inherent electrical sensitivity and vulnerability to physical stress. It is the responsibility of the buyer, when utilizing TOSHIBA products, to observe standards of safety, and to avoid situations in which a malfunction or failure of a TOSHIBA product could cause loss of human life, bodily injury or damage to property. In developing your designs, please ensure that TOSHIBA products are used within specified operating ranges as set forth in the most recent products specifications. Also, please keep in mind the precautions and conditions set forth in the TOSHIBA Semiconductor Reliability Handbook.
- The products described in this document are subject to the foreign exchange and foreign trade laws.
- The information contained herein is presented only as a guide for the applications of our products. No responsibility is assumed by TOSHIBA CORPORATION for any infringements of intellectual property or other rights of the third parties which may result from its use. No license is granted by implication or otherwise under any intellectual property or other rights of TOSHIBA CORPORATION or others.
- The information contained herein is subject to change without notice.

BLOCK DIAGRAM

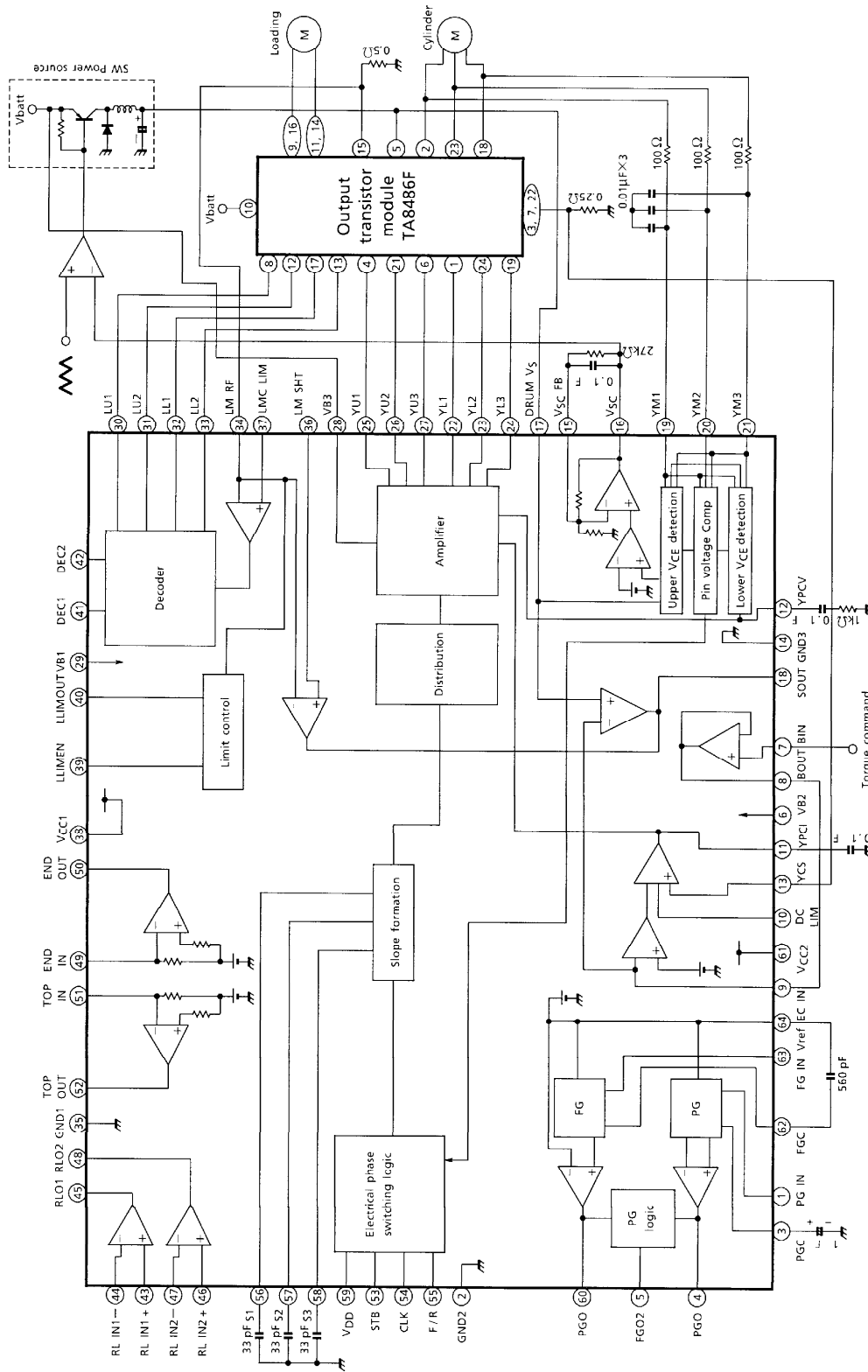

(Note) Short circuiting between output and line to ground faults may result in damage to the IC. Ensure that great care is taken during the design of the output line, VCC (VM, VS, VEE) and the GND line.

TB6525F-2

PIN DESCRIPTIONS

PIN No.	PIN SYMBOL	PIN DESCRIPTION
1	PG IN	Cylinder motor's PG signal input pin
2	GND2	Cylinder motor's PG amplifier and FG amplifier ground pin
3	PGC	Cylinder motor's condenser ground pin for signal detection
4	PGO	Cylinder motor's PG signal formation output pin
5	PGO2	Cylinder motor's PG2 signal output pin
6	VB2	Cylinder motor's battery power voltage pin for small signals
7	B IN	Cylinder motor's torque command buffer input pin
8	B OUT	Cylinder motor's torque command buffer output pin
9	EC IN	Cylinder motor's torque command input pin
10	DC LIM	Cylinder motor's input pin for current limit setting
11	YPCI	Cylinder motor's current feedback phase compensation pin
12	YPCV	Cylinder motor's voltage feedback phase compensation pin
13	YCS	Cylinder motor's current detection input pin
14	GND3	Cylinder motor's ground pin
15	V _{SC} FB	Cylinder motor's V _{SC} phase compensation pin
16	V _{SC}	Cylinder motor's SW Reg upper V _{CE} detection output pin
17	DRUM V _S	Cylinder (drum) motor's power voltage input pin
18	SOUT	Cylinder motor's short detection output pin
19	YM1	Cylinder motor's induced operation voltage detection input pin 1
20	YM2	Cylinder motor's induced operation voltage detection input pin 2
21	YM3	Cylinder motor's induced operation voltage detection input pin 3
22	YL1	Cylinder motor's lower pre-driver output pin 1
23	YL2	Cylinder motor's lower pre-driver output pin 2
24	YL3	Cylinder motor's lower pre-driver output pin 3
25	YU1	Cylinder motor's upper pre-driver output pin 1
26	YU2	Cylinder motor's upper pre-driver output pin 2
27	YU3	Cylinder motor's upper pre-driver output pin 3
28	VB3	Cylinder motor's battery power voltage pin for the pre-driver
29	VB1	Loading motor's battery power voltage pin for small signals
30	LU1	Loading motor's upper pre-driver output pin 1
31	LU2	Loading motor's upper pre-driver output pin 2
32	LL1	Loading motor's lower pre-driver output pin 1
33	LL2	Loading motor's lower pre-driver output pin 2
34	LM RF	Loading motor's current detection input pin
35	GND1	Loading motor's ground pin
36	LM SH1	Loading motor's input pin for short detection setting
37	LMC LIM	Loading motor's input pin for current limit setting
38	V _{CC1}	Loading motor's small signal power voltage pin
39	LLIMEN	Loading motor's current limit operation input pin
40	LLIMOUT	Loading motor's current limit status output pin

PIN No.	PIN SYMBOL	PIN DESCRIPTION
41	DEC1	Loading motor's decoder input pin 1
42	DEC2	Loading motor's decoder input pin 2
43	RL IN +	Loading motor's reel FG amplifier 1 positive input pin
44	RL IN -	Loading motor's reel FG amplifier 1 negative input pin
45	RLO1	Loading motor's reel FG amplifier 1 output pin
46	RL IN2 +	Loading motor's reel FG amplifier 2 positive input pin
47	RL IN2 -	Loading motor's reel FG amplifier 2 negative input pin
48	RLO2	Loading motor's reel FG amplifier 2 output pin
49	END IN	Loading motor's tape end sensor amplifier input pin
50	END OUT	Loading motor's tape end sensor amplifier output pin
51	TOP IN	Loading motor's tape top sensor amplifier input pin
52	TOP OUT	Loading motor's tape top sensor amplifier output pin
53	STB	Cylinder motor's stand-by status input pin
54	CLK	Standard clock input pin
55	F/R	Cylinder motor's forward / reverse input pin
56	S1	Cylinder motor's sine-wave formation detection pin 1
57	S2	Cylinder motor's sine-wave formation detection pin 2
58	S3	Cylinder motor's sine-wave formation detection pin 3
59	V _{DD}	Cylinder motor's logic power voltage pin
60	FGO	Cylinder motor's FG amplifier formation detection pin
61	V _{CC2}	Cylinder motor's small signal power voltage pin
62	FGC	Cylinder motor's FG amplifier phase compensation pin
63	FG IN	Cylinder motor's FG amplifier input pin
64	Vref	Cylinder motor's standard voltage output pin for the PG amplifier and FG amplifier

TRUE VALUE AREAS
Cylinder (drum) motor

INPUT		OUTPUT STATUS
STB	F / R	OUTPUT MODE (DIRECTION OF REVOLUTIONS)
H	L	YM1 → YM2 → YM3
H	H	YM3 → YM2 → YM1
L	L / H	Stand-by status

Loading motor

INPUT		OUTPUT			
DEC1	DEC2	LU1	LU2	LL1	LL2
H	H	Z	Z	H (ON)	H (ON)
H	L	L (ON)	Z	Z	H (ON)
L	H	Z	L (ON)	H (ON)	Z
L	L	Z	Z	Z	Z

Z : High impedance

Loading motor, current limit operations

LLIMEN (INPUT)	LIMITER AMPLIFIER CIRCUIT	LLIMOUT (OUTPUT)
H	Operating time (output current detection time)	L
H	When not operating	H
L	Non-operations	H

MAXIMUM RATINGS (Ta = 25°C)

CHARACTERISTIC	SYMBOL	RATING	UNIT	REMARKS
Logic Power Voltage	V _{CC}	8	V	V _{CC}
Battery Power Voltage	V _B	8	V	V _B
Output Pin Voltage	V _N	8	V	YU1, YU2, YU3, YL1, YL2, YL3, LU1, LU2, LL1, LL2
Input Pin Voltage	V _I	-0.3~ V _{CC} + 0.3	V	STB, CLK, F/R, PGIN, FGIN, ECIN, YCS, BIN, BRK, TOPIN, ENDIN, LIMEN, RF, RS, LS1, LS2, DEC1, DEC2, YVM, YM1, YM2, YM3
Power Dissipation	P _D	0.95	W	IC unit
Operating Temperature	T _{opr}	-20~75	°C	
Storage Temperature	T _{stg}	-55~125	°C	

RECOMMENDED OPERATING CONDITIONS

CHARACTERISTIC	SYMBOL	MIN	TYP.	MAX	UNIT
Logic Power Voltage	V _{CC}	2.7	2.9	5.5	V
Battery Power Voltage	V _B	4.5	4.78	7.3	V
Clock Frequency	f _{CLK}	300	333.3	500	kHz

Voltage relationship : Ensure that a $V_B \geq V_{CC} + 1.8V$ relationship has been satisfied before usage.

ELECTRICAL CHARACTERISTICS (Ta = 25°C, V_{CC} = 2.9 V, V_b = 4.78 V when not specifically designated)
Cylinder area

No.	CHARACTERISTIC	SYMBOL	TEST CIRCUIT	TEST CONDITION	MIN	TYP.	MAX	UNIT
1	Power Supply Current (1)	I _{CC} (1)	—	CYL operations, LM is BRAKE	—	40	60	mA
2	Power Supply Current (2)	I _{CC} (2)	—	CYL operations, LM is STOP	—	6.2	15	mA
3	Power Supply Current (3)	I _{CC} (3)	—	CYL is STB, LM is CW / CCW	—	19	30	mA
4	Power Supply Current (4)	I _{CC} (4)	—	CYL is STB, LM is STOP	—	3.8	10	mA
5	Battery Power Current (1)	I _b (1)	—	CYL operations, LM is BRAKE	—	26	40	mA
6	Battery Power Current (2)	I _b (2)	—	CYL is STB, LM is STOP	—	80	150	μA
7	Buffer (B) Amplifier Input Current	B _{lin}	—		—	0.06	2	μA
8	B Amplifier Common-mode Input Voltage Range	B _{cmr}	—		0	—	2.9	V
9	B Amplifier Output Voltage	V _{outb}	—	V _{IN} = 1.5 V, I _o = ±100 μA	1.45	1.5	1.55	V
10	EC Amplifier Input Current (1)	E _{lin} (1)	—	ECIN = 0 V	—	0.5	4	μA
11	EC Amplifier Input Current (2)	E _{lin} (2)	—	ECEN = 2.9 V	—	50	70	μA
12	EC Amplifier Common-mode Input Voltage Range	E _{cmr}	—		0	—	2.9	V
13	PCI Amplifier Output Voltage	I _{PCI}	—	PCI = 0 V, ECIN = 2.9 V	70	100	150	μA
14	PCV Amplifier Output Voltage	I _{PCV}	—		10	20	30	μA
15	I/O Gain	G _{io}	—	ECIN = 0.5 to 0.6 V	0.04	0.08	0.12	
16	Dead Point	V _{dead}	—		0.2	0.3	0.6	V
17	Maximum Output Voltage	C _{Smax}	—	ECIN = 2.9 V, R _F = 0.25 Ω	0.15	0.18	0.22	V
18	Lower Output Voltage (1)	V _L (1)	—	CS = 50 mV	0.1	0.2	0.3	V
19	Lower Output Voltage (2)	V _L (2)	—	ECIN = 2.9 V	0.2	0.4	0.6	V
20	Upper Drive Current	Y _{IU}	—		15	22	—	mA
21	Lower Drive Current	Y _{IL}	—		15	43	—	mA
22	SC Operation Point (1)	V _{sc} (1)	—	ECIN = 0.2 V, V _{SC} = 1.5 V	0.06	0.15	0.2	V
23	SC Operation Point (2)	V _{sc} (2)	—	ECIN = 2.9 V, V _{SC} = 1.5 V	0.7	0.93	1.2	V
24	SC Gain	G _{sc}	—	ECIN = 0.5 V, V _M = 0.2 to 0.3 V	17	23	25	dB
25	V _{sc} FB Input Current (H)	I _{sc} FB (H)	—	V _{sc} = L, V _{sc} FB = V _{CC}	330	450	550	μA
26	V _{sc} FB Input Current (L)	I _{sc} FB (L)	—	V _{sc} = H, V _{sc} FB = 0 V	46	60	76	μA
27	FG Input Current	I _{FG}	—	FGIN = 0.5 V	—	0.2	2	μA
28	FG Common-mode Input Voltage Range	FG _{cmr}	—		0.5	—	1.9	V
29	FG Amplifier Sensitivity	FG _{sens}	—	p-p Voltage	20	—	—	mV
30	FG	"H" Level	FG (H)	I _o = 10 μA	2.4	2.6	—	V
31		"L" Level	FG (L)	I _o = 10 μA	—	0.05	0.4	V
32	PG Amplifier Sensitivity	PG _{sens}	—	p-p Voltage	6	—	—	mV
33	PG Common-mode Input Voltage Range	PG _{cmr}	—		0.5	—	1.9	V

No.	CHARACTERISTIC		SYMBOL	TEST CIR-CUIT	TEST CONDITION	MIN	TYP.	MAX	UNIT
34	P G	"H" level	PG (H)	—	$I_o = 10 \mu A$	2.4	2.6	—	V
35		"L" level	PG (L)	—	$I_o = 10 \mu A$	—	0.05	0.4	V
36	PGC Voltage (1)		VPGC (1)	—	PGIN = 1 kHz, Duty = 80% PGC = 1 μF	0.95	—	1.35	V
37	PGC Voltage (2)		VPGC (2)	—	PGIN = 1 kHz, Duty = 20% PGC = 1 μF	0.7	—	0.9	V
38	PG02 Output Voltage (H)		VPG02(H)	—	$I_o = 10 \mu A$	2.5	—	—	V
39	PG02 Output Voltage (L)		VPG02 (L)	—	$I_o = 10 \mu A$	—	—	0.4	V
40	Vref Voltage		Vref	—	$I_o = \pm 500 \mu A$	1.1	1.31	1.5	V
41	Logic Input Voltage (H)		IN (H)	—	STB, F/R, CLK pin	2.0	—	—	V
42	Logic Input Voltage (L)		IN (L)	—	STB, F/R, CLK pin	—	—	0.6	V
43	Stand-by Input Current		ISTB	—	VSTB = V_{CC}	—	—	1	μA
44	YLIMIT Common-mode Input Voltage Range		YLcmr	—		0	—	1.0	V
45	YLIMIT Input Current		IYL	—	YLIMIT = 0 V, ECIN = 2.9 V	—	—	2	μA
46	YLIMIT Operations		YL	—	YL = 0.05 V, ECIN = 2.9 V	30	40	50	mV
47	Sout	"H" level	Sout (H)	—	ECIN = 2.9 V, DVS = 3.0 V	2.2	2.6	—	V
48		"L" level	Sout (L)	—	ECIN = 2.9 V, DVS = 2.8 V	—	0.05	0.5	V

Loading area

No.	CHARACTERISTIC		SYMBOL	TEST CIR-CUIT	TEST CONDITION	MIN	TYP.	MAX	UNIT
49	DEC Input Voltage	"H" Level	VDEC (H)	—		2.0	—	—	V
50		"L" Level	VDEC (L)	—		—	—	0.6	V
51	DEC Input Current (H)		IDEC (H)	—	DEC = V_{CC}	—	—	1	μA
52	DEC Input Current (L)		IDEC (L)	—	DEC = 0 V	—	—	1	μA
53	LIMEN Input Voltage	"H" Level	VLE (H)	—		2.0	—	—	V
54		"L" Level	VLE (L)	—		—	—	0.6	V
55	LIMEN Input Current (H)		ILE (H)	—	LIMEN = V_{CC}	—	0.9	5	μA
56	LIMEN Input Current (L)		ILE (L)	—	LIMEN = 0 V	—	—	1	μA
57	Upper Drive Current		LIU	—		10	15	—	mA
58	Lower Drive Current		LIL	—		10	15	—	mA
59	Current Limiter Standard Voltage Input Range		LLcmr	—		0	—	1	V
60	RS Input Current		ILL	—	RS = 0 V	—	0.1	2	μA
61	Current Limiter Detection Voltage		LL	—	RS = 0.2 V, RF = 0.5 V	0.18	0.2	0.22	V
62	Current Limiter Detection Output Voltage (H)		Lout (H)	—	$I_o = 10 \mu A$	2.4	2.8	—	V
63	Current Limiter Detection Output Voltage (L)		Lout (L)	—	$I_o = 10 \mu A$	—	0.12	0.5	V

No.	CHARACTERISTIC	SYMBOL	TEST CIR-CUIT	TEST CONDITION	MIN	TYP.	MAX	UNIT
64	Short Detection Pin Input Current	IREFR	—	REFR = 0 V	—	0.3	2	μ A
65	Short Detection Output Level (H)	SSout (H)	—	REFR = 0.8 V, RF = 0.6 V	2.2	2.6	—	V
66	Short Detection Output Level (L)	SSout (L)	—	REFR = 0.8 V, RF = 1.0 V	—	0.1	0.5	V
67	Reel FG Amplifier CMR	Rcmr	—		1.2	—	2.5	V
68	Reel FG Amplifier Input Current	Rlin	—	RLIN = 2.5 V	—	0.3	2	μ A
69	Reel FG Amplifier Hysteresis	Rhys	—	V_{p-p}	—	9	—	mV
70	Reel FG Amplifier Input Sensitivity	Rsens	—	V_{0-p}	13	—	—	mV
71	Reel FG Amplifier Remaining Output Voltage (H)	RVout (H)	—	$I_o = 10 \mu$ A	2.5	—	—	V
72	Reel FG Amplifier Remaining Output Voltage (L)	RVout (L)	—	$I_o = 10 \mu$ A	—	—	0.4	V
73	Top End Sensor CMR	TEcmr	—		0.5	—	1.9	V
74	Top End Sensor Input Current	TElin	—	IN = 0.5 V	100	200	300	μ A
75	Top End Sensor Hysteresis	TEhys	—		—	60	—	mV
76	Top End Sensor Input Sensitivity	TEsens	—	V_{p-p}	90	—	—	mV
77	Top End Sensor Output Voltage (H)	TEout (H)	—	$I_o = 20 \mu$ A	2.5	2.8	—	V
78	Top End Sensor Output Voltage (L)	TEout (L)	—	$I_o = 20 \mu$ A	—	0.04	0.4	V

PACKAGE DIMENSIONS
QFP64-P-1010-0.50C

Unit : mm

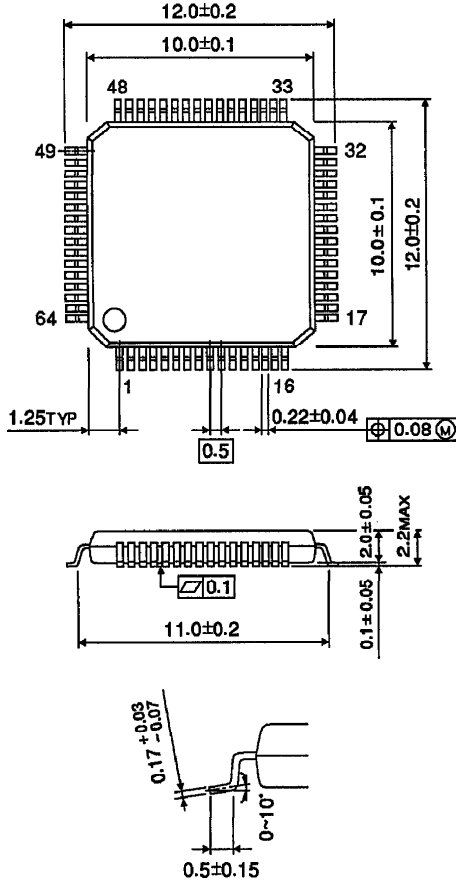

Weight : 0.48 g (Typ.)