

TOSHIBA BiCD Integrated Circuit Silicon Monolithic

TB6557FLG

DC Motor Driver

The TB6557FLG is a driver IC for driving DC motors. Its employs LDMOS devices with low ON resistance for output drive transistors. The TB6557FLG incorporates two constant current-controlled H-bridge drivers and four voltage-controlled H-bridge drivers, making it ideal for controlling Zoom/AF/IRIS lens motors in digital still cameras and camcorders. It supports three-wire serial data to control motors, thus reducing the number of lines for interfacing the control IC.

Features

- Motor power supply voltage: $V_M \leq 15$ V (max)
- Control power supply voltage: $V_{CC} = 2.7$ to 6 V
- Output current: $I_{out} \leq 0.8$ A (max)
- P-/N-ch LDMOS complementary output transistors
- Output ON resistance: R_{on} (upper + lower) = 1.5 Ω (typ.)
- High-speed PWM chopping control at 100 kHz or higher (constant-current H-SW)
- Independent standby (Power save) feature
- Two 6-bit DACs for setting current value for constant-current H-SW
- Thermal shutdown (TSD) protective circuit
- Circuit for preventing malfunction at low voltage (shuts down internal circuits at $UVLO: V_{CC} \leq 2.2$ V (typ.)).
- Small QON-36 package (0.5-mm lead pitch)
- Supports Pb-free reflow mounting

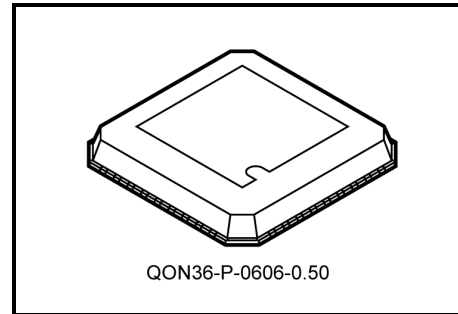

Weight: 0.08 g (typ.)

The TB6557FLG is a Pb-free product.
The following conditions apply to solderability:
*Solderability

1. Use of Sn-37Pb solder bath
 - *solder bath temperature = 230°C
 - *dipping time = 5 seconds
 - *number of times = once
 - *use of R-type flux
2. Use of Sn-3.0Ag-0.5Cu solder bath
 - *solder bath temperature = 245°C
 - *dipping time = 5 seconds
 - *number of times = once
 - *use of R-type flux

Note: This product has a MOS structure and is sensitive to electrostatic discharge. When handling this product, ensure that the environment is protected against electrostatic discharge by using an earth strap, a conductive mat and an ionizer. Ensure also that the ambient temperature and relative humidity are maintained at reasonable levels.

Block Diagram

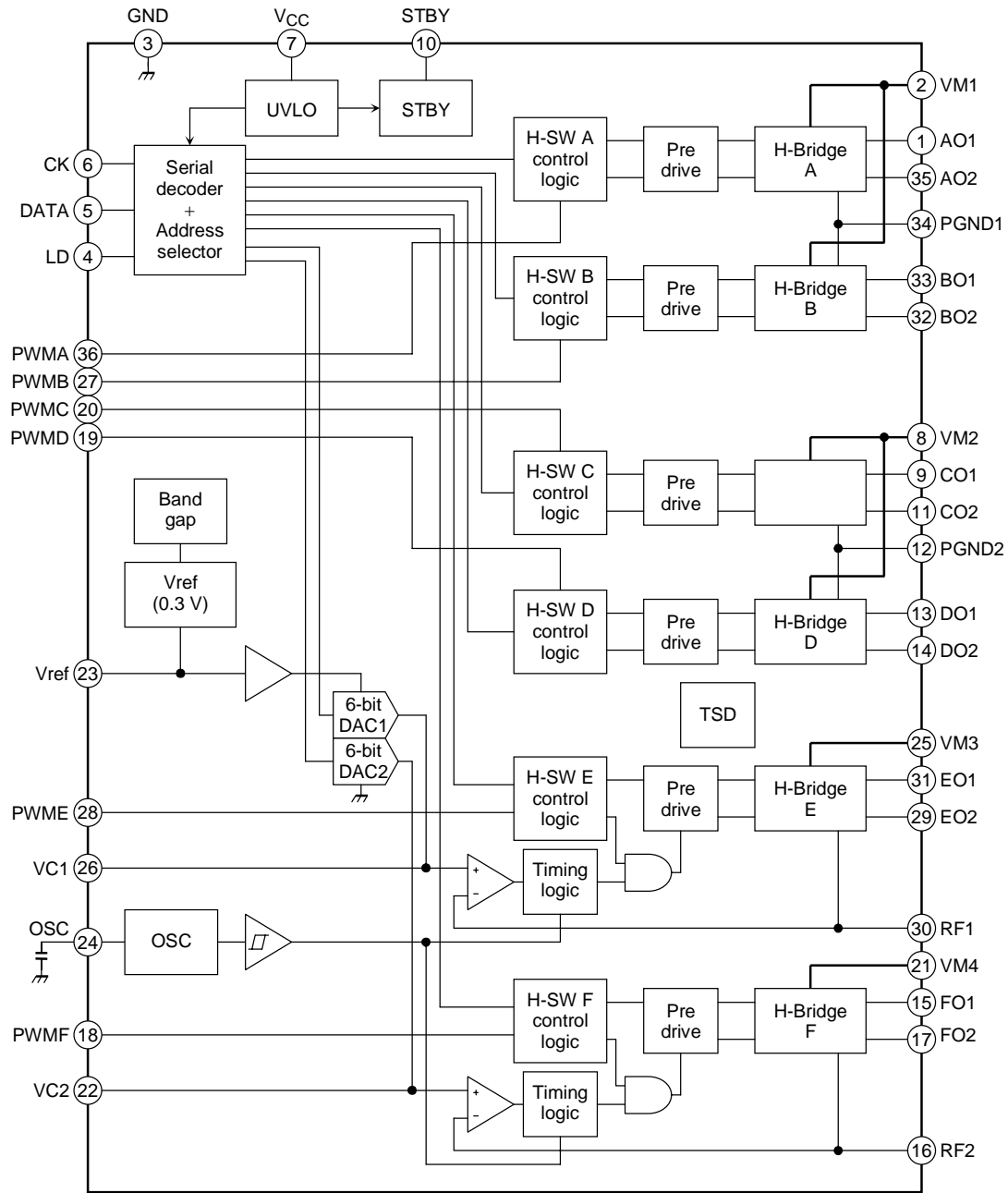

Absolute Maximum Ratings (Ta = 25°C)

Characteristics	Symbol	Rating	Unit	Remarks
Supply voltage	V _{CC}	6	V	V _{CC}
Motor supply voltage	V _M	15	V	V _M
Output pin voltage	V _{OUT}	15	V	
Output current	I _{OUT}	0.8	A	
Input voltage	V _{IN}	-0.2 to 6	V	Each control input pin
Power dissipation	P _D	0.6	W	IC only
Operating temperature	T _{opr}	-20 to 85	°C	
Storage temperature	T _{stg}	-55 to 150	°C	

Recommended Operating Conditions (Ta = -20 to 85°C)

Characteristics	Symbol	Rating			Unit
		Min	Typ.	Max	
Small signal supply voltage	V _{CC}	2.7	3	5.5	V
Motor supply voltage	V _M	2.5	5	13.5	V
Output current	I _{OUT}	—	—	600	mA
PWM frequency	f _{PWM}	—	—	100	kHz
OSC oscillation frequency	f _{OSC}	—	—	1	MHz

Recommended Operating Conditions 2: Serial Data Controller (Ta = -20 to 85°C)

Characteristics	Symbol	Rating		Unit
		Min	Max	
Low-level clock pulse width	t_{CKL}	200	—	ns
High-level clock pulse width	t_{CKH}	200	—	ns
Clock rise time	t_{Cr}	—	50	ns
Clock fall time	t_{Cf}	—	50	ns
Data setup time	t_{DCH}	30	—	ns
Data hold time	t_{CHD}	60	—	ns
Load setup time	t_{CHL}	200	—	ns
Load hold time	t_{LDC}	100	—	ns
High-level load pulse width	t_{LDH}	100	—	ns
Latch output settling time	t_{LDD}	—	100	μ s
CK (clock pulse) frequency	f_{CLK}	—	2.5	MHz
LD (load pulse) frequency	f_{LD}	—	1.5	MHz

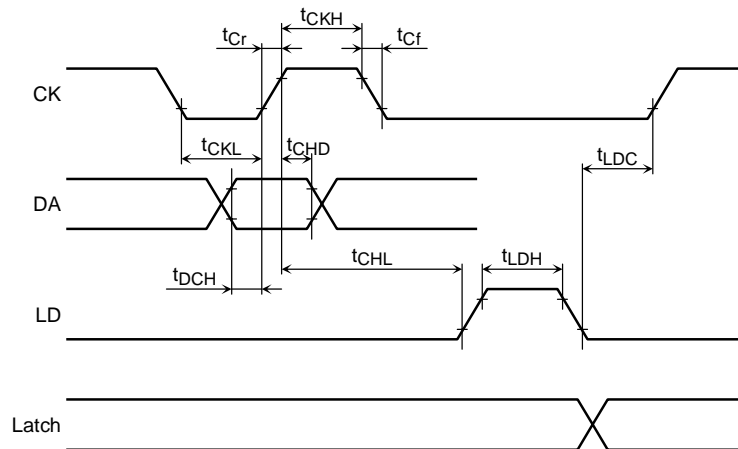

Specifications and Operation of Each Circuit Block:

- Bridge output block:

PWM control feature

While PWM control is applied, normal operation t_1 , t_5 , and short brake t_3 are repeated.

(Dead time t_2 and t_4 are inserted to prevent pass-through current.)

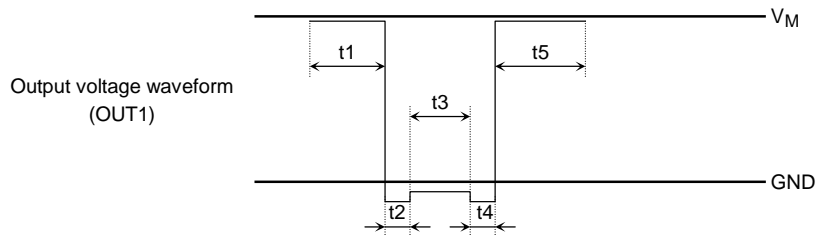
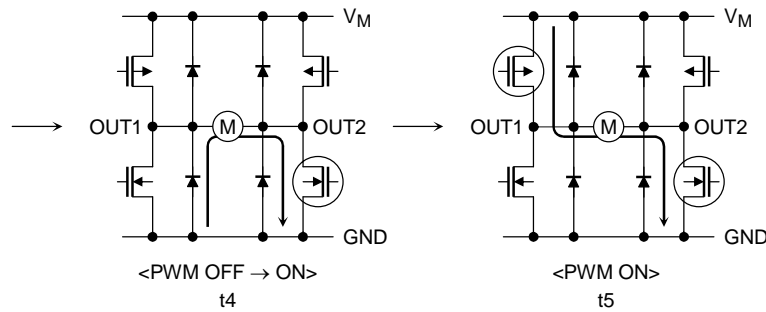
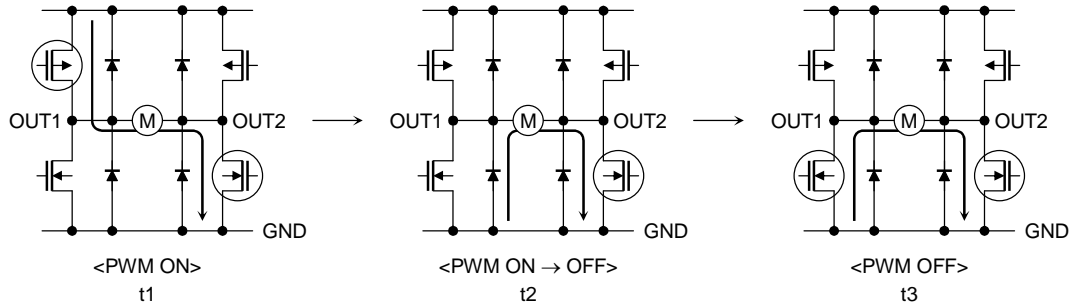

Operation of OSC oscillator: Charging and discharging external capacitor C_{OSC} cause OSC oscillation.

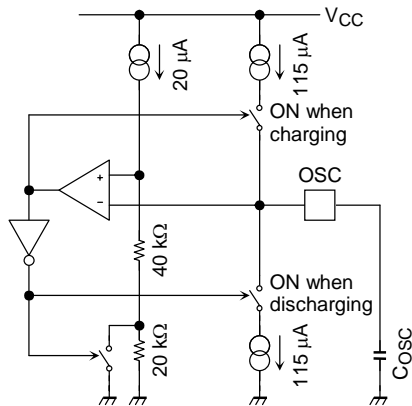

OSC block

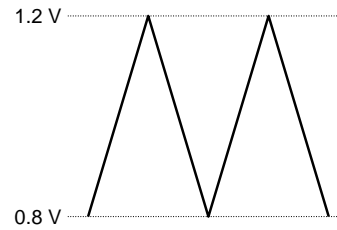

V_{OSC} waveform

In the above circuit configuration, the voltage inclination, V_{OSC}, for charging (or discharging) external capacitor C_{OSC} is represented as follows:

$$V_{OSC} = \frac{1}{C_{OSC}} \int i dt$$

The following equations show relationships among t₁ (time when V_{OSC} = 0.8 V), t₂ (time when V_{OSC} = 1.2 V), and ΔV_{OSC} (variation in the V_{OSC} inclination):

$$\Delta V_{OSC} = I \times (t_1 - t_2) / C_{OSC}$$

$$\frac{1}{t_1 - t_2} = \frac{I}{\Delta V_{OSC} \cdot C_{OSC}}$$

The triangular oscillation frequency, f_{OSC}, represents a single period consisting of a pair of rising V_{OSC} inclination and falling inclination, so that the period is double the time between t₁ and t₂.

∴ Therefore, the relationship between C_{OSC} and f_{OSC} is shown by the following formula:

$$f_{OSC} = \frac{1}{2(t_1 - t_2)} = \frac{I}{2 \cdot \Delta V_{OSC} \cdot C_{OSC}}$$

With the above OSC block and V_{OSC} waveform, V_{OSC} = |1.2 V - 0.8 V| = 0.4 V, so that the value of f_{OSC} is determined from the following formula:

$$f_{OSC} = \frac{1}{2 \times 0.4 / 115 \mu A \times C_{OSC}} = \frac{1}{6.957 \times 10^3 \times C_{OSC}}$$

Example: The calculation shows f_{OSC} = 532 kHz when C_{OSC} = 270 pF and f_{OSC} = 256 kHz when C_{OSC} = 560 pF.

In an actual application, however, the required capacitance may slightly differ from the theoretical value due to board pin capacitance and other factors. It is, therefore, recommended to determine the value of C_{OSC} experimentally.

- Constant-current bridge block (H-SW E, F): Description of PWM constant-current chopping**
 Turning on the power (Chop on) causes current to flow into the load inductor. Once the voltage (VRF) generated with the external current detection resistor reaches the comparator reference voltage, VLimit (current limit), the comparator starts operating (Chop off). After the output Hi-side transistor is turned off, counting for the chop-off time starts at the next rising edge of the internal clock, producing a chop-off time of clock cycles for nine bits (reset at the rising edge for the 10th bit).
 This chop-off time control creates a PWM signal to turn the output transistor on and off.

Conceptual diagram for PWM chopping operation

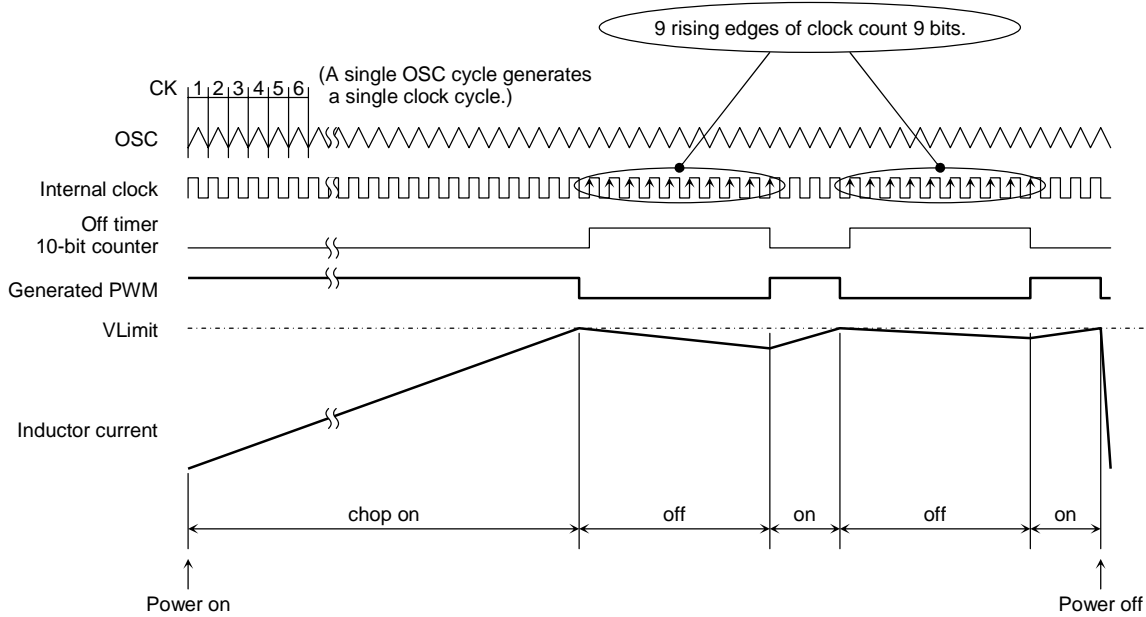

(The inductor current (I_O peak) is limited by the value obtained from the expression $I_O = V_{\text{Limit}}/R_{\text{NF}}$.)

- Others**
 Each input pin (CK, DA, LD, PWM-A, B, C, D, E, F, and STBY) has a built-in pull-down resistor (approx. 200 kΩ)

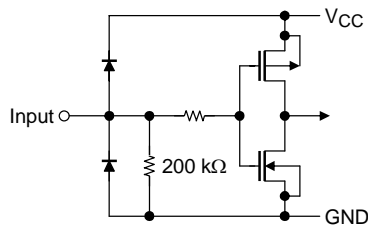

Serial Data Specifications:

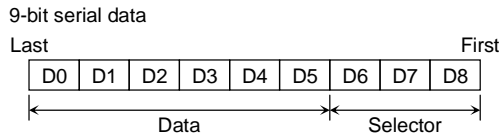

Register modes

D8	D7	D6	D5	D4	D3	D2	D1	D0	Register	Remarks
0	0	0	mod2	mod1	p2a	p2b	p1a	p1b	0	ChA, ChB setting
0	0	1	mod4	mod3	p4a	p4b	p3a	p3b	1	ChC, ChD setting
0	1	0	mod6	mod5	p6a	p6b	p5a	p5b	2	ChE, ChF setting
0	1	1	pwm6	pwm5	pwm4	pwm3	pwm2	pwm1	3	PWM mode setting
1	0	0	DA5	DA4	DA3	DA2	DA1	DA0	4	DAC1 setting
1	0	1	DA5	DA4	DA3	DA2	DA1	DA0	5	DAC2 setting
1	1	1	0	0	0	0	0	0	—	Reset

Driver function table

modX = 0 pwmX = 0

pxa	pxb	PWMx	OUTxA	OUTxB	Operating Mode
L	L	X	Z	Z	STOP
L	H	L	L	L	Short brake
L	H	H	L	H	CCW
H	L	L	L	L	Short brake
H	L	H	H	L	CW
H	H	X	L	L	Short brake

modX = 0 pwmX = 1

pxa	pxb	PWMx	OUTxA	OUTxB	Operating Mode
L	L	X	Z	Z	STOP
L	H	L	L	H	CCW
L	H	H	L	L	Short brake
H	L	L	H	L	CW
H	L	H	L	L	Short brake
H	H	X	L	L	Short brake

modX = 1 pwmX = X

pxa	pxb	PWMx	OUTxA	OUTxB	Operating Mode
L	X	X	Z	Z	STOP
H	L	L	H	L	CW
H	L	H	L	H	CCW
H	H	X	L	L	Short brake

Serial Decoder Block Diagram

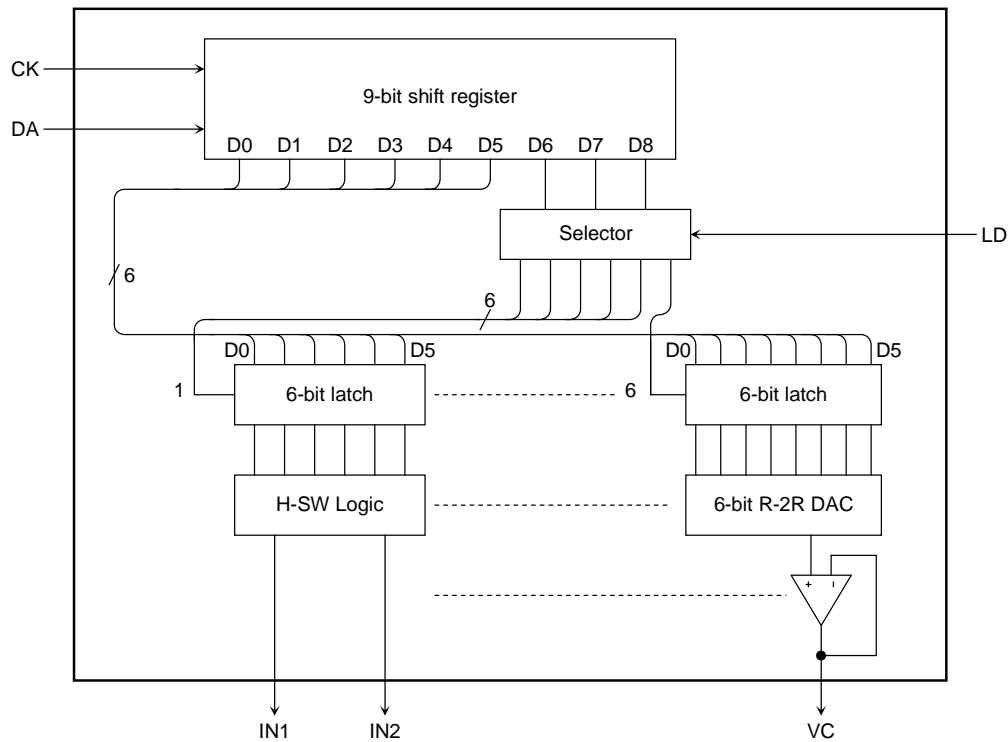

Example Timing Chart

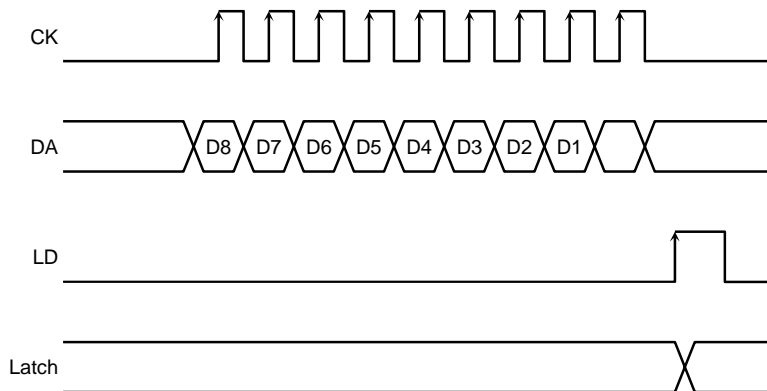

The 9-bit serial data, input to the DA pin, is detected on the rising edge of CK, and then serially stored into the 9-bit register.

- (1) The three bits in D8 to D6 select the register.
- (2) The six bits in D5 to D0 specify the H-SW control mode or DAC output value.
- (3) Data is output from the latch on the rising edge of the signal input to the LD pin.

Note: Driving the standby pin (pin 10) low resets the internal register.
The internal register is also reset in the default status upon power-on.

Electrical Characteristics ($V_{CC} = 3\text{ V}$, $V_M = 5\text{ V}$, and $T_a = 25^\circ\text{C}$ unless otherwise specified)

Characteristics		Symbol	Test Condition	Min	Typ.	Max	Unit
Supply current		I_{CC}	All 6 channels in CW mode	—	3	5	mA
		$I_{CC}(\text{STB})$	Standby mode	—	—	10	μA
		$I_M(\text{STB})$		—	—	1	
Serial/standby input	Input voltage	V_{INH}		$V_{CC} \times 1/2$	—	$V_{CC} + 0.2$	V
		V_{INL}		-0.2	—	0.4	
	Input current	I_{INH}	$V_{\text{IH}} = 3\text{ V}$	10	15	20	μA
		I_{INL}	$V_{\text{IL}} = 0\text{ V}$	—	—	1	
PWM input	Input voltage	V_{INSH}		2	—	$V_{CC} + 0.2$	V
		$V_{\text{IN}}(\text{HYS})$	(Design value)	—	0.2	—	
		V_{INSL}		-0.2	—	0.8	
	Input current	I_{INSH}	$V_{\text{IH}} = 3\text{ V}$	10	15	20	μA
		I_{INSL}	$V_{\text{IL}} = 0\text{ V}$	—	—	1	
Output saturation voltage		$V_{\text{sat}}(\text{U} + \text{L})$	$I_{\text{O}} = 0.2\text{ A}$	—	0.3		V
			$I_{\text{O}} = 0.6\text{ A}$	—	0.9		
Output leakage current		$I_{\text{L}}(\text{U})$	$V_M = 15\text{ V}$	—	—	1	μA
		$I_{\text{L}}(\text{L})$		—	—	1	
Output diode forward voltage		$V_{\text{F}}(\text{U})$	$I_{\text{F}} = 0.6\text{ A}$ (Design value)	—	1	—	V
		$V_{\text{F}}(\text{L})$		—	1	—	
Internal reference voltage		V_{ref}		0.28	0.3	0.32	V
Offset voltage for constant-current detection comparator		Comp ofs	$\text{RRF} = 1\ \Omega$, $V_{\text{C}} = 0.1\text{ V}$ (Design value)	-5	—	5	mV
Reference oscillation frequency		f_{OSC}	$\text{C}_{\text{osc}} = 220\text{ pF}$	430	530	630	kHZ
DAC	Nonlinearity error	LB		-3	—	3	LSB
	Differential linearity error	DLB		-2	—	2	
	Output voltage range	DR		0	—	2.7	
Thermal shutdown circuit operating temperature		TSD	(Design value)	—	170	—	$^\circ\text{C}$
Hysteresis temperature width for recovery from thermal shutdown		ΔTSD		—	20	—	

Example Application Circuit

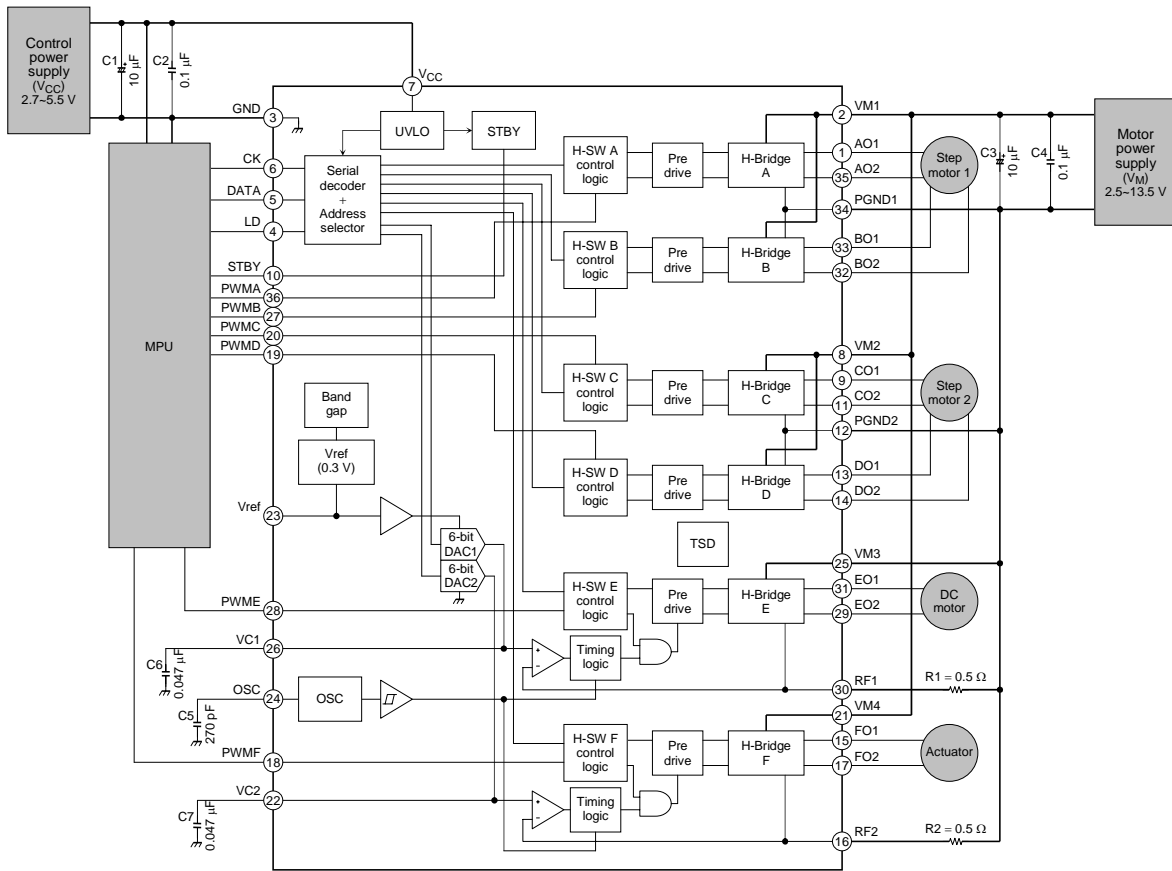

Requests Concerning Use of QON

Outline Drawing of Package

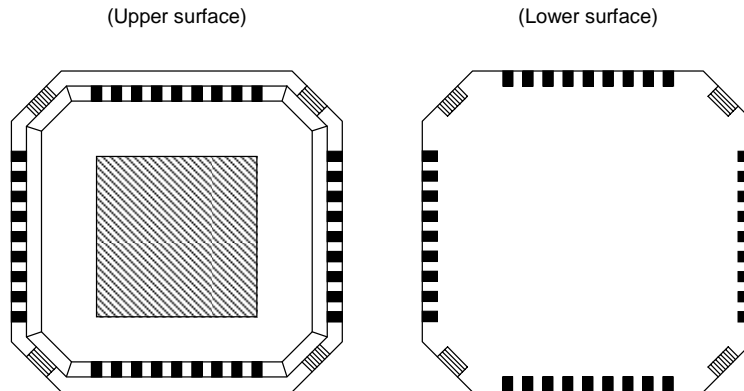

When using QON, please take into account the following items.

Caution

- (1) Do not carry out soldering on the island section in the four corners of the package (the section shown on the lower surface drawing with diagonal lines) with the aim of increasing mechanical strength.
- (2) The island section exposed on the package surface (the section shown on the upper surface drawing with diagonal lines) must be used as (Note) below while electrically insulated from outside.

Note: Ensure that the island section (the section shown on the lower surface drawing with diagonal lines) does not come into contact with solder from through-holes on the board layout.

- When mounting or soldering, take care to ensure that neither static electricity nor electrical overstress is applied to the IC (measures to prevent anti-static, leaks, etc.).
- When incorporating into a set, adopt a set design that does not apply voltage directly to the island section.

Package Dimensions

QON36-P-0606-0.50

Unit: mm

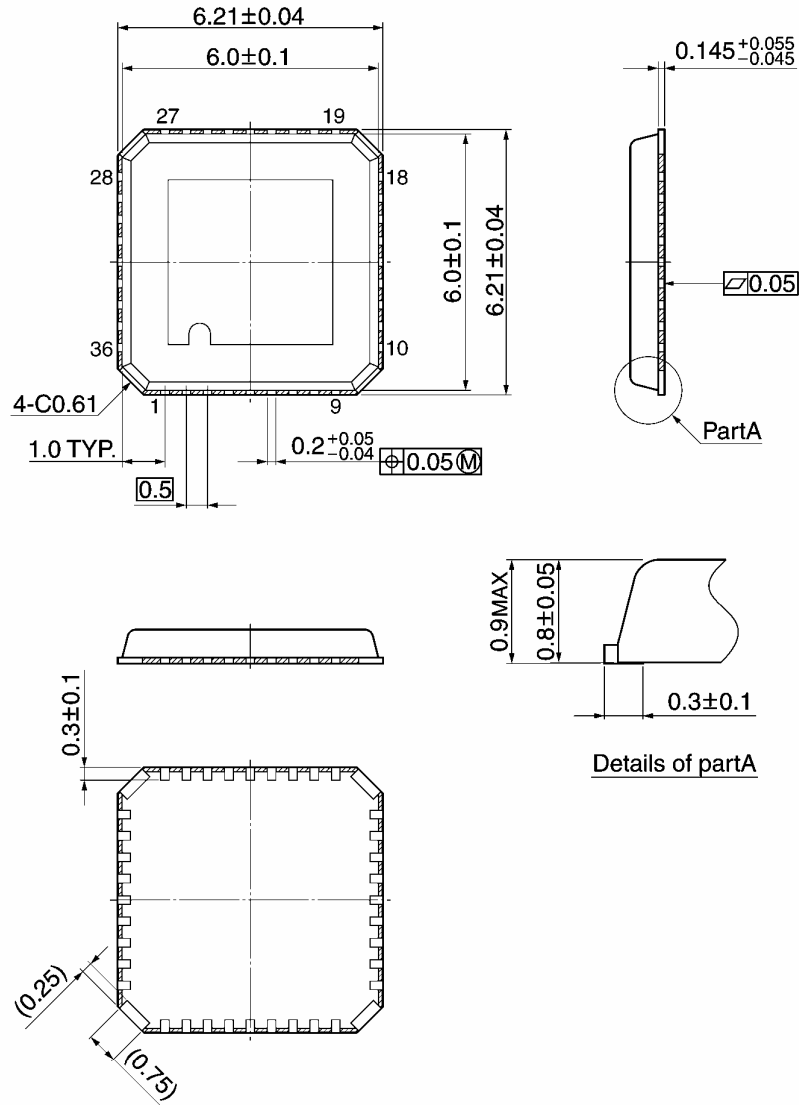

- Note 1) The solder plating portion in four corners of the package shall not be treated as an external terminal.
- Note 2) Don't carry out soldering to four corners of the package.
- Note 3)  area : Resin surface

Weight: 0.08 g (typ.)

Notes on Contents

1. Block Diagrams

Some of the functional blocks, circuits, or constants in the block diagram may be omitted or simplified for explanatory purposes.

2. Equivalent Circuits

The equivalent circuit diagrams may be simplified or some parts of them may be omitted for explanatory purposes.

3. Timing Charts

Timing charts may be simplified for explanatory purposes.

4. Application Circuits

The application circuits shown in this document are provided for reference purposes only. Thorough evaluation is required, especially at the mass production design stage.

Toshiba does not grant any license to any industrial property rights by providing these examples of application circuits.

5. Test Circuits

Components in the test circuits are used only to obtain and confirm the device characteristics. These components and circuits are not guaranteed to prevent malfunction or failure from occurring in the application equipment.

IC Usage Considerations

Notes on handling of ICs

- [1] The absolute maximum ratings of a semiconductor device are a set of ratings that must not be exceeded, even for a moment. Do not exceed any of these ratings.
Exceeding the rating(s) may cause the device breakdown, damage or deterioration, and may result injury by explosion or combustion.
- [2] Use an appropriate power supply fuse to ensure that a large current does not continuously flow in case of over current and/or IC failure. The IC will fully break down when used under conditions that exceed its absolute maximum ratings, when the wiring is routed improperly or when an abnormal pulse noise occurs from the wiring or load, causing a large current to continuously flow and the breakdown can lead smoke or ignition. To minimize the effects of the flow of a large current in case of breakdown, appropriate settings, such as fuse capacity, fusing time and insertion circuit location, are required.
- [3] If your design includes an inductive load such as a motor coil, incorporate a protection circuit into the design to prevent device malfunction or breakdown caused by the current resulting from the inrush current at power ON or the negative current resulting from the back electromotive force at power OFF. IC breakdown may cause injury, smoke or ignition.
Use a stable power supply with ICs with built-in protection functions. If the power supply is unstable, the protection function may not operate, causing IC breakdown. IC breakdown may cause injury, smoke or ignition.
- [4] Do not insert devices in the wrong orientation or incorrectly.
Make sure that the positive and negative terminals of power supplies are connected properly. Otherwise, the current or power consumption may exceed the absolute maximum rating, and exceeding the rating(s) may cause the device breakdown, damage or deterioration, and may result injury by explosion or combustion.
In addition, do not use any device that is applied the current with inserting in the wrong orientation or incorrectly even just one time.

Points to remember on handling of ICs**(1) Thermal Shutdown Circuit**

Thermal shutdown circuits do not necessarily protect ICs under all circumstances. If the thermal shutdown circuits operate against the over temperature, clear the heat generation status immediately.

Depending on the method of use and usage conditions, such as exceeding absolute maximum ratings can cause the thermal shutdown circuit to not operate properly or IC breakdown before operation.

(2) Heat Radiation Design

In using an IC with large current flow such as power amp, regulator or driver, please design the device so that heat is appropriately radiated, not to exceed the specified junction temperature (T_j) at any time and condition. These ICs generate heat even during normal use. An inadequate IC heat radiation design can lead to decrease in IC life, deterioration of IC characteristics or IC breakdown. In addition, please design the device taking into consideration the effect of IC heat radiation with peripheral components.

(3) Back-EMF

When a motor rotates in the reverse direction, stops or slows down abruptly, a current flow back to the motor's power supply due to the effect of back-EMF. If the current sink capability of the power supply is small, the device's motor power supply and output pins might be exposed to conditions beyond maximum ratings. To avoid this problem, take the effect of back-EMF into consideration in system design.

RESTRICTIONS ON PRODUCT USE

060116EBA

- The information contained herein is subject to change without notice. 021023_D
- TOSHIBA is continually working to improve the quality and reliability of its products. Nevertheless, semiconductor devices in general can malfunction or fail due to their inherent electrical sensitivity and vulnerability to physical stress. It is the responsibility of the buyer, when utilizing TOSHIBA products, to comply with the standards of safety in making a safe design for the entire system, and to avoid situations in which a malfunction or failure of such TOSHIBA products could cause loss of human life, bodily injury or damage to property.
In developing your designs, please ensure that TOSHIBA products are used within specified operating ranges as set forth in the most recent TOSHIBA products specifications. Also, please keep in mind the precautions and conditions set forth in the "Handling Guide for Semiconductor Devices," or "TOSHIBA Semiconductor Reliability Handbook" etc. 021023_A
- The TOSHIBA products listed in this document are intended for usage in general electronics applications (computer, personal equipment, office equipment, measuring equipment, industrial robotics, domestic appliances, etc.). These TOSHIBA products are neither intended nor warranted for usage in equipment that requires extraordinarily high quality and/or reliability or a malfunction or failure of which may cause loss of human life or bodily injury ("Unintended Usage"). Unintended Usage include atomic energy control instruments, airplane or spaceship instruments, transportation instruments, traffic signal instruments, combustion control instruments, medical instruments, all types of safety devices, etc. Unintended Usage of TOSHIBA products listed in this document shall be made at the customer's own risk. 021023_B
- The products described in this document shall not be used or embedded to any downstream products of which manufacture, use and/or sale are prohibited under any applicable laws and regulations. 060106_Q
- The information contained herein is presented only as a guide for the applications of our products. No responsibility is assumed by TOSHIBA for any infringements of patents or other rights of the third parties which may result from its use. No license is granted by implication or otherwise under any patent or patent rights of TOSHIBA or others. 021023_C
- The products described in this document are subject to the foreign exchange and foreign trade laws. 021023_E