

Low Voltage CMOS Driver Circuit

Description

The e5130 contains 4 independent driver outputs with an ON resistance of typ. 25 Ω (15 Ω) for the P-channel output transistors and typ. 20 Ω (13 Ω) for the N-channel output transistors; at a supply voltage of 1.5 V (3 V). To obtain a fast transition of the outputs, even for slow rise/-fall time input signals, all digital inputs (IN1 ... IN4) have a schmitt-trigger characteristic; with a hysteresis of

typ. 50 mV. If a higher driving capability is needed, all inputs and outputs may be connected in parallel. In this case the rise/-fall time of the input signals IN1 ... IN4 must be less than 200 nsec. Due to the fast switching characteristic of the tristatable output drivers, the circuit is also suited as low voltage bus driver.

Features

- 1.1 – 3.6 V operating voltage range
- 4 non-inverting, tristatable drivers for the following applications:
 - Motor driver for bipolar stepper motors in watch/clock applications
 - Driver for piezoelectric transducers (buzzer)
 - LED Driver
 - Line driver for medium speed applications

Advantages

- High load current at low supply voltage
- Replaces several discrete transistors
- Tri-state operation possible
- Possible applications:
 - Motor driver
 - Radio controlled clock/watch
 - Line driver for mini-computer, laptop
 - LED driver
 - Relay driver

Pad Configuration

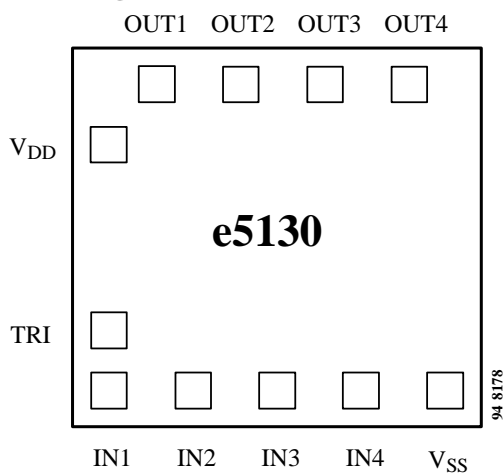

Name	Description
V _{DD}	Positive supply voltage
V _{SS}	Negative supply voltage
IN1 ... IN4	Digital inputs
TRI	Tristate input
OUT1 ... OUT4	Drive outputs

Chipsize: x = 1.08 mm, y = 1.42 mm,
Padwindow: 90 x 90 μ

Ordering Information

Extended Type Number	Package	Remarks
e5130A-DIT	Die	Die in Trays

Absolute Maximum Ratings

Absolute maximum ratings define parameter limits which, if exceeded, may permanently change or damage the device. All inputs and outputs on circuits are highly protected against electrostatic discharges.

However, precautions to minimize build-up of electrostatic charges during handling are recommended.

The circuits are protected against supply voltage reversal for typically 5 minutes, if the current is limited to 120 mA.

Parameters	Symbol	Value	Unit
Supply voltage	$V_{DD} - V_{SS}$	- 0.3 to + 5	V
Input voltage range, all inputs	V_I	$V_{SS} - 0.3$ to $V_{DD} + 0.3$	V
Operating ambient temperature range		- 20 to + 70	°C
Storage temperature range		- 40 to + 125	°C
Lead temperature during soldering at 2 mm distance, 10 s		260	°C

Operating Characteristics

$V_{SS} = 0$ V, $V_{DD} = + 1.5$ V, $T_{amb} = + 25$ °C, unless otherwise specified.

All voltage levels are measured with reference to V_{SS} .

Parameters	Test Conditions / Pin	Symbol	Min	Typ	Max	Unit
Operating voltage		V_{DD}	1.1		3.6	V
Operating temperature		T_{amb}	- 10		60	°C
Operating current (standby)	$V_{DD} = 3.6$ V, $R_{L12} = R_{L34} = \infty$, IN1 to IN4 at V_{DD} or V_{SS} , TRI at V_{SS}	I_{DD}		0.05	1	μA
Drive output OUT1 to OUT4						
Output current	$V_{DD} = 1.2$ V, $R_{L12} = R_{L34} = 200$ Ω	I_{OUT}	± 4.3	± 4.75		mA
Output current	$V_{DD} = 1.5$ V, $R_{L12} = R_{L34} = 200$ Ω	I_{OUT}	± 5.7	± 6.20		mA
Output current	$V_{DD} = 3.0$ V, $R_{L12} = R_{L34} = 200$ Ω	I_{OUT}	± 12	± 13		mA
Delay time	$V_{DD} = 3$ V, $C_L = 50$ pF	T_{Dr} , T_{Df}		35	60	ns
Delay time	$V_{DD} = 1.5$ V, $C_L = 50$ pF, see figure 2, note 1	T_{Dr} , T_{Df}		80	150	ns
Rise/-fall time	$V_{DD} = 3$ V, $C_L = 50$ pF	t_r , t_f		8	15	ns
Rise/-fall time	$V_{DD} = 1.5$ V, $C_L = 50$ pF, see figure 2, note 2	t_r , t_f		12	25	ns
Digital input IN1 to IN4						
Input current	$V_{IL} = 0$ V	I_{IL}			-100	nA
Input current	$V_{IH} = V_{DD}$	I_{IH}			100	nA
Threshold	V	V_{TH}		$V_{DD}/2$		V
Hysteresis	mV	V_{HYST}		50		mV
Tristate input TRI						
Input current TRI	$V_{IH} = V_{DD}$	I_{IH}	0.15	0.4	1.2	μA

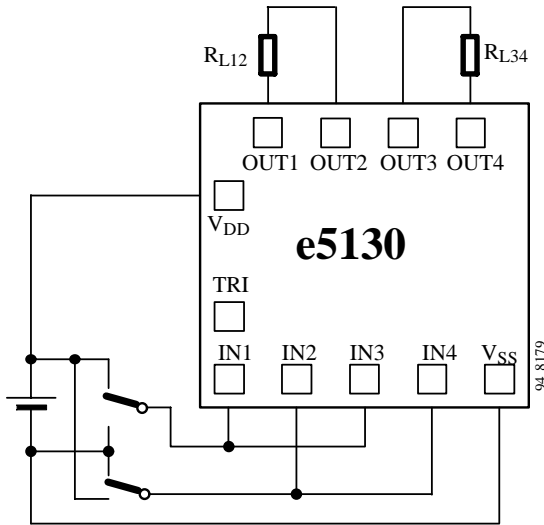

Figure 1. Test circuit

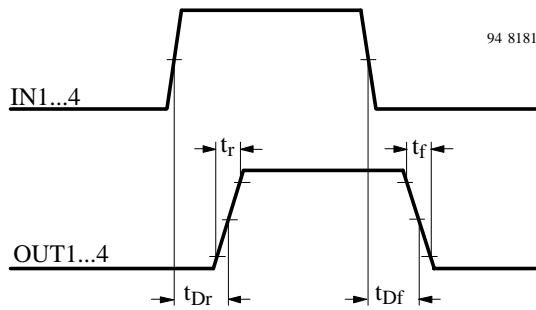

Figure 2.

Note 1: t_{Dr} , t_{Df} is defined at 50% of supply voltage
 Note 2: t_r , t_f is defined from 10% to 90%, resp. 90% to 10% of supply voltage

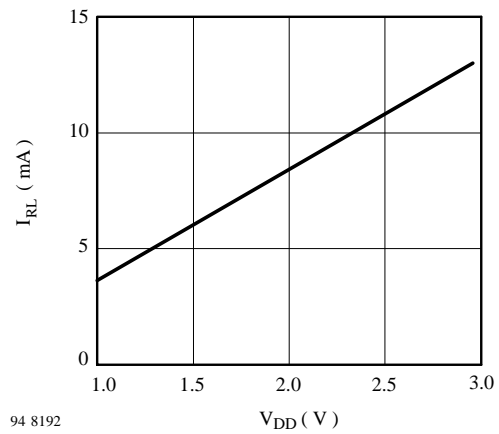

Figure 3. Typical current into 200 Ω load resistor, condition as per figure 1

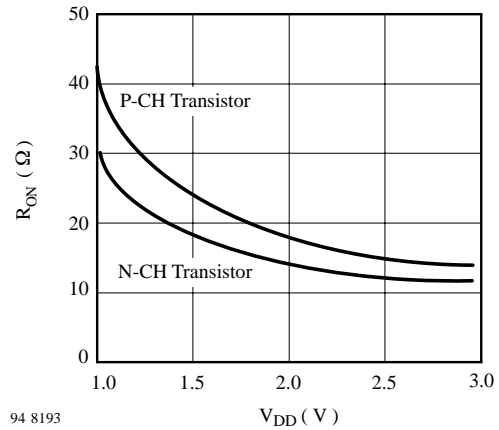

Figure 4. Typical output on-resistance vs. supply voltage at $V_{DS} = 0.2$ V

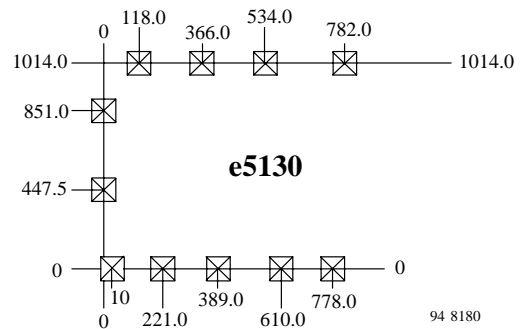
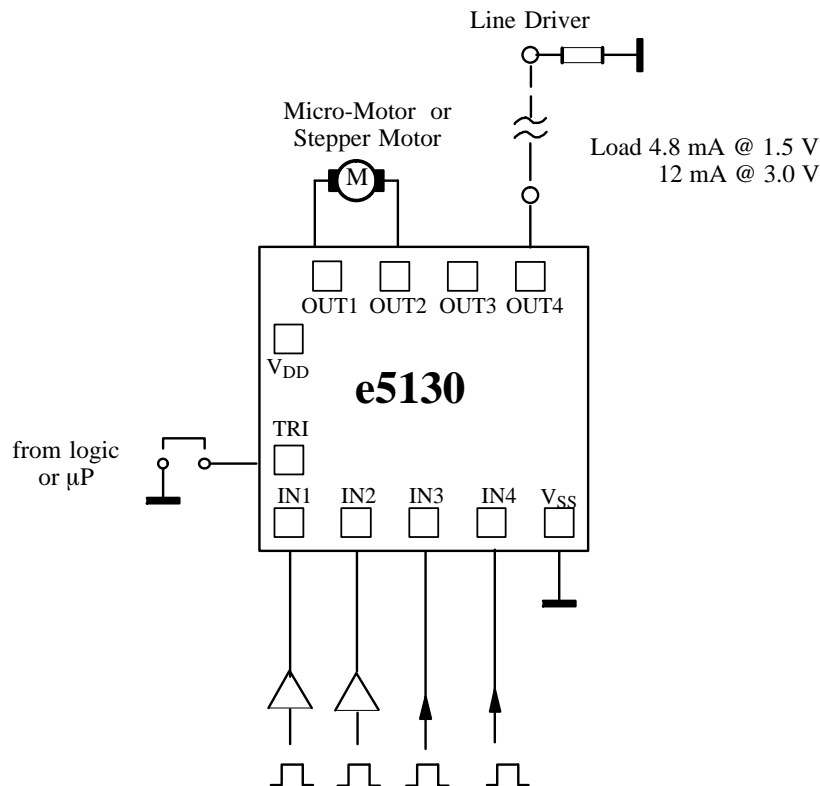

Figure 5. Pad coordinates

Application Circuit



We reserve the right to make changes to improve technical design and may do so without further notice.

Parameters can vary in different applications. All operating parameters must be validated for each customer application by the customer. Should the buyer use Atmel Wireless & Microcontrollers products for any unintended or unauthorized application, the buyer shall indemnify Atmel Wireless & Microcontrollers against all claims, costs, damages, and expenses, arising out of, directly or indirectly, any claim of personal damage, injury or death associated with such unintended or unauthorized use.

Data sheets can also be retrieved from the Internet: <http://www.atmel-wm.com>

Atmel Germany GmbH, P.O.B. 3535, D-74025 Heilbronn, Germany
 Telephone: 49 (0)7131 67 2594, Fax number: 49 (0)7131 67 2423