

Power management IC with LIN and high speed CAN

Features

- Two 5V voltage regulators for microcontroller and peripheral supply
- No electrolytic capacitor required on regulator outputs
- Ultra low quiescent current in standby modes
- Programmable reset generator for power-on and undervoltage
- Configurable window watchdog and fail safe output
- LIN 2.1 compliant (SAEJ2602 compatible) transceiver
- Advanced HS CAN transceiver (ISO 11898-2/-5 and SAE J2284 compliant) with local failure and bus failure diagnosis
- HS CAN transceiver supports partial networking
- Complete 3-channel contact monitoring interface with programmable cyclic sense functionality
- Programmable periodic system wake-up feature
- ST SPI interface for mode control and diagnosis
- 5 fully protected high-side drivers with internal 4-channel PWM generator
- 2 low-side drivers with active Zener clamping
- 4 internal PWM timers
- 2 operational amplifiers with rail-to-rail outputs (V_S) and low voltage inputs
- Temperature warning and thermal shutdown

Applications

- Automotive ECU's such as door zone and body control modules



Description

The L99PM62GXP is a power management system IC that provides electronic control units with enhanced system power supply functionality, including various standby modes, as well as LIN and HS CAN physical communication layers. The device's two low-drop voltage regulators supply the system microcontroller and external peripheral loads such as sensors and provide enhanced system standby functionality with programmable local and remote wake-up capability.

In addition, five high-side drivers, two low-side drivers and two operational amplifiers increase the system integration level.

The ST standard SPI interface (3.0) allows control and diagnosis of the device and enables generic software development.

Table 1. Device summary

Package	Order codes	
	Tube	Tape and reel
PowerSSO-36	L99PM62GXP	L99PM62GXPTR

Contents

1	Block diagram and pin descriptions	9
2	Detailed description	12
2.1	Voltage regulators	12
2.1.1	Voltage regulator: V_1	12
2.1.2	Voltage regulator: V_2	13
2.1.3	Increased output current capability for voltage regulator V_2	13
2.1.4	Voltage regulator failure	15
2.1.5	Voltage regulator behaviour	16
2.2	Operating modes	16
2.2.1	Active mode	16
2.2.2	Flash mode	17
2.2.3	V_1 standby mode	17
2.2.4	VBAT standby mode	18
2.2.5	Wake up from standby modes	18
2.2.6	Wake-up inputs	19
2.2.7	Cyclic contact supply	19
2.2.8	Timer interrupt / wake-up of microcontroller by timer	19
2.3	Functional overview (truth table)	20
2.4	Configurable window watchdog	21
2.4.1	Change watchdog timing	23
2.5	Fail safe mode	25
2.5.1	Single failures	25
2.5.2	Multiple failures – entering forced V_{BAT} standby mode	27
2.6	Reset output (NRESET)	28
2.7	Operational amplifiers	28
2.8	LIN bus interface	28
2.8.1	Error handling	29
2.8.2	Wake up (from LIN)	29
2.8.3	LIN pull-up	30
2.9	High speed CAN bus transceiver	30
2.9.1	CAN error handling	31
2.9.2	Wake up (from CAN)	31

2.9.3	CAN sleep mode	33
2.9.4	CAN receive only mode	33
2.9.5	CAN looping mode	33
2.10	Serial peripheral interface (ST SPI standard)	33
3	Protection and diagnosis	35
3.1	Power supply fail	35
3.1.1	V _S overvoltage	35
3.1.2	V _S undervoltage	35
3.2	Temperature warning and thermal shutdown	37
3.3	High-side driver outputs	38
3.4	Low-side driver outputs REL1, REL2	39
3.5	SPI diagnosis	40
4	Typical application	41
5	Electrical specifications	42
5.1	Absolute maximum rating	42
5.2	ESD protection	43
5.3	Thermal data	43
5.4	Package and PCB thermal data	45
5.4.1	PowerSSO-36 thermal data	45
5.5	Electrical characteristics	48
5.5.1	Supply and supply monitoring	48
5.5.2	Oscillator	49
5.5.3	Power-on reset (VS)	49
5.5.4	Voltage regulator V ₁	49
5.5.5	Voltage regulator V ₂	50
5.5.6	Reset output	51
5.5.7	Watchdog	51
5.5.8	High-side outputs	53
5.5.9	Relay drivers	54
5.5.10	Wake up inputs (WU1... WU3)	55
5.5.11	High speed CAN transceiver	55
5.5.12	LIN transceiver	58
5.5.13	Operational amplifier	61

5.5.14	SPI	62
5.5.15	Inputs TxD_C and TxD_L for Flash mode	65
6	ST SPI	69
6.1	SPI communication flow	69
6.1.1	General description	69
6.1.2	Operating code definition	69
6.1.3	Global status register	70
6.1.4	Configuration register	70
6.1.5	Address mapping	72
6.1.6	Write operation	72
6.1.7	Format of data shifted out at SDO during write cycle	73
6.1.8	Read operation	74
6.1.9	Format of data shifted out at SDO during read cycle	75
6.1.10	Read and clear status operation	76
6.1.11	Read device information	77
6.2	SPI registers	79
6.2.1	Overview	79
6.2.2	Control registers	81
6.2.3	Status registers	93
7	Package and packing information	99
7.1	ECOPACK®	99
7.2	PowerSSO-36 package information	99
8	Revision history	101

List of tables

Table 1.	Device summary	1
Table 2.	Pin definition	10
Table 3.	Wake up sources	18
Table 4.	Functional overview (truth table).	20
Table 5.	Fail safe conditions and exit modes	26
Table 6.	Persisting fail safe conditions and exit modes	27
Table 7.	PWM configuration for high-side outputs	38
Table 8.	Absolute maximum rating	42
Table 9.	ESD protection	43
Table 10.	Operating junction temperature	43
Table 11.	Temperature warning and thermal shutdown	43
Table 12.	Thermal parameter	47
Table 13.	Supply and supply monitoring.	48
Table 14.	Oscillator.	49
Table 15.	Power-on reset (Vs)	49
Table 16.	Voltage regulator V ₁	49
Table 17.	Voltage regulator V ₂	50
Table 18.	Reset output	51
Table 19.	Watchdog	51
Table 20.	Output (OUT_HS)	53
Table 21.	Outputs (OUT1...4)	54
Table 22.	Relay drivers.	54
Table 23.	Wake up inputs (WU1... WU3)	55
Table 24.	CAN communication operating range.	55
Table 25.	CAN transmit data input: pin TXDC	55
Table 26.	CAN receive data output: pin RXDC.	56
Table 27.	CAN bus common mode stabilization output termination: pin SPLIT	56
Table 28.	CAN transmitter and receiver: pins CANH and CANL	56
Table 29.	CAN transceiver timing	58
Table 30.	LIN transmit data input: pin TXD.	58
Table 31.	LIN receive data output: pin RXD	58
Table 32.	LIN transmitter and receiver: pin LIN	58
Table 33.	LIN transceiver timing	60
Table 34.	LIN pull-up: pin LINPU	61
Table 35.	Operational amplifier.	61
Table 36.	Input: CSN	62
Table 37.	Input CLK, DI	62
Table 38.	DI timing	63
Table 39.	DO output pin	63
Table 40.	DO timing	64
Table 41.	CSN timing	64
Table 42.	RXDL/NINT timing	65
Table 43.	Inputs TxD_C and TxD_L for Flash mode	65
Table 44.	Command byte	69
Table 45.	Operating code definition	69
Table 46.	Global status register	70
Table 47.	Configuration register	70
Table 48.	Address mapping	72

Table 49.	Write command format: command byte	72
Table 50.	Write command format: data byte 1	73
Table 51.	Write command format: data byte 2	73
Table 52.	Format of data shifted out at SDO during write cycle: global status register	73
Table 53.	Format of data shifted out at SDO during write cycle: data byte 1	73
Table 54.	Format of data shifted out at SDO during write cycle: data byte 2	73
Table 55.	Read command format: command byte	74
Table 56.	Read command format: data byte 1	74
Table 57.	Read command format: data byte 2	74
Table 58.	Format of data shifted out at SDO during read cycle: global status register	75
Table 59.	Format of data shifted out at SDO during read cycle: data byte 1	75
Table 60.	Format of data shifted out at SDO during read cycle: data byte 2	75
Table 61.	Read and clear status command format: command byte	76
Table 62.	Read and clear status command format: data byte 1	76
Table 63.	Read and clear status command format: data byte 2	76
Table 64.	Format of data shifted out at SDO during read and clear status: global status register	76
Table 65.	Format of data shifted out at SDO during read and clear status: data byte 1	76
Table 66.	Format of data shifted out at SDO during read and clear status: data byte 2	77
Table 67.	Read device information	77
Table 68.	ID-header	78
Table 69.	Family identifier	78
Table 70.	Silicon version identifier	78
Table 71.	SPI-frame-ID	79
Table 72.	SPI register: command byte	79
Table 73.	SPI register: mode selection	79
Table 74.	SPI register: CTRL register selection	79
Table 75.	SPI register: STAT register selection	80
Table 76.	Overview of control registers data bytes	81
Table 77.	Control register 1: command and data bytes	82
Table 78.	Control register 1, data bytes	82
Table 79.	Control register 1, bits	82
Table 80.	Control register 2: command and data bytes	84
Table 81.	Control register 2, data bytes	84
Table 82.	Control register 2, bits	85
Table 83.	Control register 3: command data bytes	85
Table 84.	Control register 3, data bytes	85
Table 85.	Control register 3, bits	86
Table 86.	Control register 4: command and data bytes	87
Table 87.	Control register 4, data bytes	88
Table 88.	Control register 4, bits	88
Table 89.	Control register 5: command and data bytes	90
Table 90.	Control register 5, data bytes	90
Table 91.	Control register 5, bits	90
Table 92.	Control register 6: command and data bytes	91
Table 93.	Control register 6, data bytes	91
Table 94.	Control register 6, bits	92
Table 95.	Overview of status register data bytes	93
Table 96.	Global status register	93
Table 97.	Status register 1: command and data bytes	94
Table 98.	Status register 1, data bytes	94
Table 99.	Status register 1, bits	95
Table 100.	Status register 2: command and data bytes	96

Table 101.	Status register 2, data bytes	96
Table 102.	Status register 2, bits	96
Table 103.	Status register 3: command and data bytes	97
Table 104.	Status register 3, data bytes	97
Table 105.	Status register 3, bits	97
Table 106.	PowerSSO-36 mechanical data	100
Table 107.	Document revision history	101

List of figures

Figure 1.	Block diagram	9
Figure 2.	Pin connection (top view)	11
Figure 3.	Voltage source with external PNP	13
Figure 4.	Voltage source with external PNP and current limitation	13
Figure 5.	Voltage source with external NPN	14
Figure 6.	Voltage source with external NPN and current limitation	14
Figure 7.	Voltage regulator behaviour and diagnosis during supply voltage ramp-up / ramp-down conditions	16
Figure 8.	Operating modes	21
Figure 9.	Watchdog in normal operating mode (no errors)	22
Figure 10.	Watchdog with error conditions	23
Figure 11.	Watchdog in Flash mode	23
Figure 12.	Change watchdog timing within long open window	24
Figure 13.	Change watchdog timing within window mode	24
Figure 14.	General procedure to change watchdog timing out of fail safe mode	25
Figure 15.	Change watchdog timing out of fail safe mode (watchdog failure)	25
Figure 16.	Example: exit fail safe mode from watchdog failure	27
Figure 17.	LIN master node configuration using LIN_PU (optional)	30
Figure 18.	CAN wake up capabilities	32
Figure 19.	Over voltage and under voltage protection and diagnosis	36
Figure 20.	Thermal shutdown protection and diagnosis	37
Figure 21.	Phase shifted PWM	39
Figure 22.	Typical application diagram	41
Figure 23.	Thermal data of PowerSSO-36	44
Figure 24.	PowerSSO-36 PC board	45
Figure 25.	PowerSSO-36 Thermal Resistance junction to ambient vs PCB copper area (V1 ON)	46
Figure 26.	PowerSSO-36 Thermal Impedance junction to ambient vs PCB copper area (single pulse with V1 ON)	46
Figure 27.	PowerSSO-36 thermal fitting model (V1 ON)	47
Figure 28.	Watchdog timing (long, early, late and safe window)	52
Figure 29.	Watchdog early, late and safe windows	53
Figure 30.	LIN transmit, receive timing	61
Figure 31.	SPI – transfer timing diagram	65
Figure 32.	SPI - input timing	66
Figure 33.	SPI output timing (part 1)	67
Figure 34.	SPI output timing (part 2)	68
Figure 35.	SPI – CSN low to high transition and global status bit access	68
Figure 36.	Read configuration register ⁽¹⁾	71
Figure 37.	Write configuration register ⁽¹⁾	71
Figure 38.	Format of data shifted out at SDO during write cycle	74
Figure 39.	Format of data shifted out at SDO during read cycle	75
Figure 40.	Format of data shifted out at SDO during read and clear status operation	77
Figure 41.	PowerSSO-36 package dimensions	99

1 Block diagram and pin descriptions

Figure 1. Block diagram

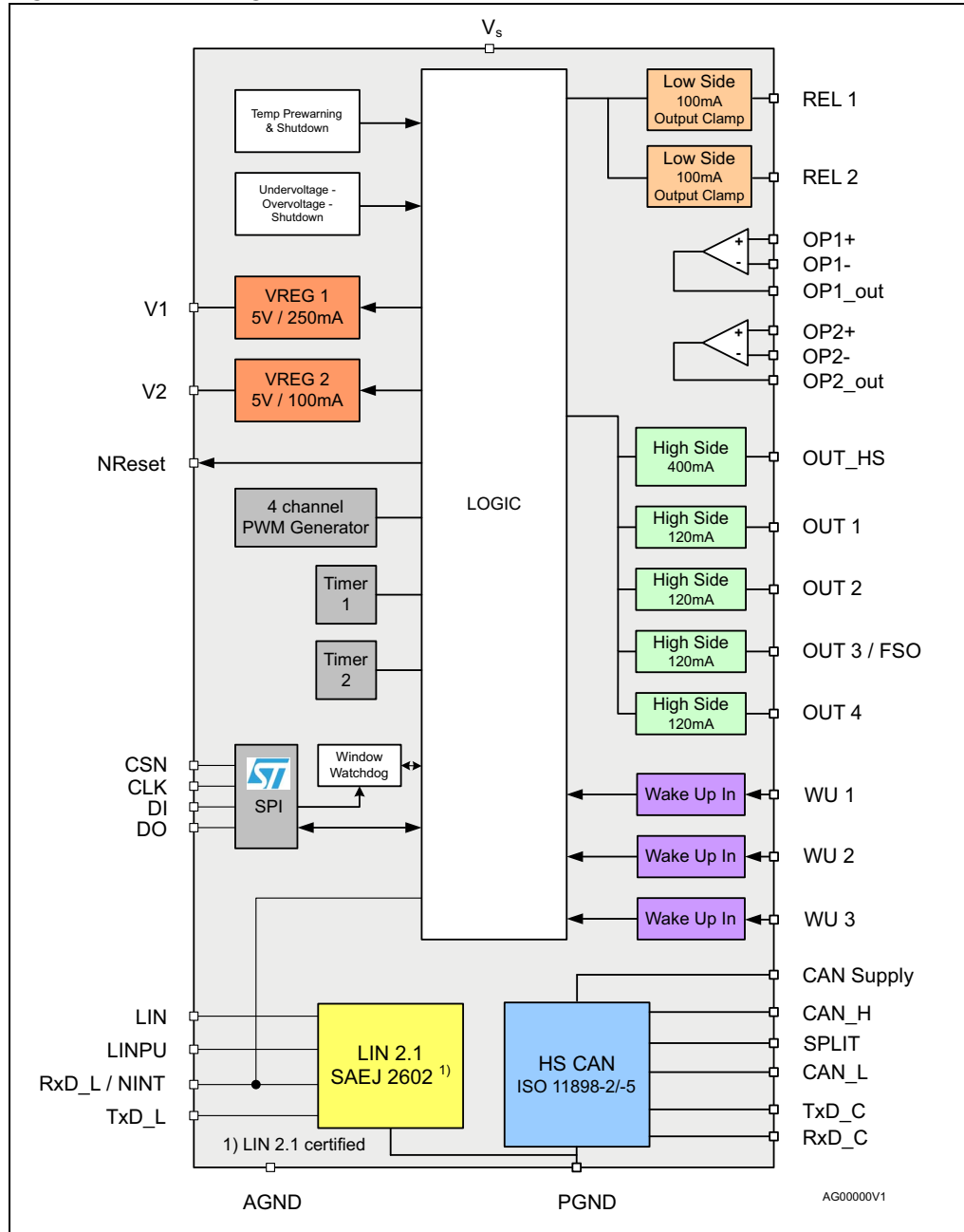
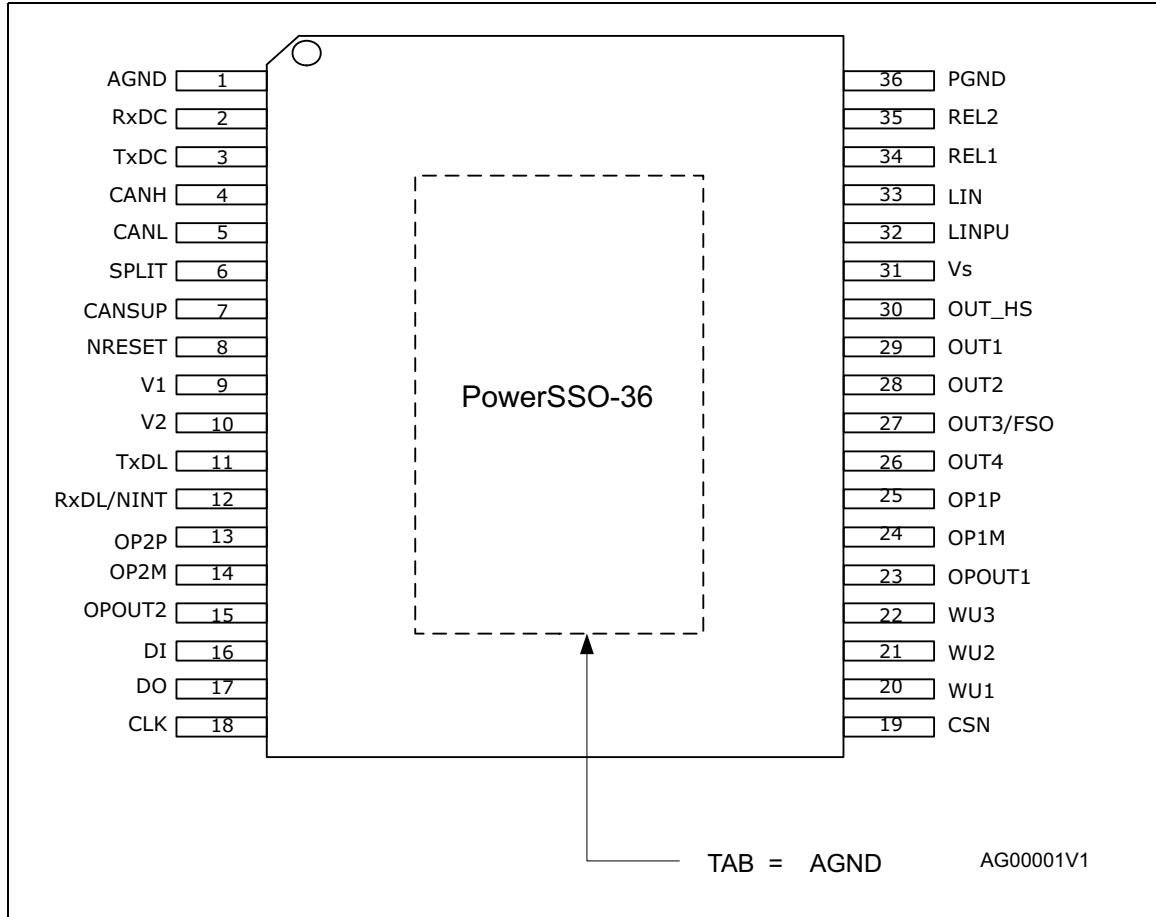

Table 2. Pin definition

Pin	Symbol	Function
1	AGND	Analog ground
2	RxDC	CAN receive data output
3	TxDC	CAN transmit data input
4	CANH	CAN high level voltage I/O
5	CANL	CAN low level voltage I/O
6	SPLIT	CAN reference voltage output, CAN termination
7	CANSUP	CAN supply input; to allow external CAN supply from V ₁ or V ₂ regulator.
8	NRESET	NReset output to micro controller; Internal pull-up of typical 100 K Ω (reset state = LOW)
9	V ₁	Voltage regulator 1 output: 5 V supply e.g. micro controller, CAN transceiver
10	V ₂	Voltage regulator 2 output: 5 V supply for external loads (IR receiver, potentiometer, sensors) or CAN Transceiver. V ₂ is protected against reverse supply.
11	TxDL	LIN Transmit data input
12	RxDL/NINT	RxDL -> LIN receive data output NINT -> indicates local/remote wake-up events or provides a programmable timer interrupt signal
13	OP2+	Non inverting input of operational amplifier 2
14	OP2-	Inverting input of operational amplifier 2
15	OP2_OUT	Output of operational amplifier 2
16	DI	SPI: serial data input
17	DO	SPI: serial data output
18	CLK	SPI: serial clock input
19	CSN	SPI: chip select not input
20...22	WU1...3	Wake-up Inputs 1 to 3: Input pins for static or cyclic monitoring of external contacts
23	OP1_OUT	Output of operational amplifier 1
24	OP1-	Inverting input of operational amplifier 1
25	OP1+	Non inverting input of operational amplifier 1
26	OUT4	High-side driver output (7 Ω , typ)
27	OUT3/FSO	Configurable as high-side driver output (7 Ω , typ) or fail safe output pin (default)
28	OUT2	High-side driver output (7 Ω , typ)
29	OUT1	High-side driver output (7 Ω , typ)
30	OUT_HS	High-side driver (1 Ω , typ)
31	V _S	Power supply voltage
32	LINPU	High-side driver output to switch off LIN master pull up resistor
33	LIN	LIN bus line
34	REL1	Low-side driver output (2 Ω typ)

Table 2. Pin definition (continued)

Pin	Symbol	Function
35	REL2	Low-side driver output (2 Ω typ)
36	PGND	Power ground (REL1/2, LIN and CAN GND), to be externally connected to AGND

Figure 2. Pin connection (top view)

Note: It is recommended to connect the PGND and AGND pins directly to the TAB.

2 Detailed description

2.1 Voltage regulators

The L99PM62GXP contains two independent and fully protected low drop voltage regulators, which are designed for very fast transient response and don't require electrolytic output capacitors for stability.

The output voltage is stable with ceramic load capacitors ≥ 220 nF.

2.1.1 Voltage regulator: V_1

The V_1 voltage regulator provides 5 V supply voltage and up to 250 mA continuous load current and is mainly intended for supply of the system microcontroller. The V_1 regulator is embedded in the power management and fail-safe functionality of the device and operates according to the selected operating mode.

It can be used to supply the internal HS CAN Transceiver via the CANSUP pin externally. In case of a short circuit condition on the CAN bus, the output current of the transmitter is limited to 100 mA and the transceiver is turned off in order to ensure continued supply of the microcontroller.

In addition the regulator V_1 drives the L99PM62GXP internal 5 V loads. The voltage regulator is protected against overload and overtemperature. An external reverse current protection has to be provided by the application circuitry to prevent the input capacitor from being discharged by negative transients or low input voltage. Current limitation of the regulator ensures fast charge of external bypass capacitors. The output voltage is stable for ceramic load capacitors ≥ 220 nF.

If the device temperature exceeds the TSD1 threshold, all outputs (OUTx, RELx, V_2 , LIN) is deactivated except V_1 . Hence the micro controller has the possibility for interaction or error logging. In case of exceeding TSD2 threshold (TSD2>TSD1), also V_1 is deactivated (see state chart in [Chapter 3: Protection and diagnosis](#)). A timer is started and the voltage regulator is deactivated for $t_{TSD} = 1$ sec. During this time, all other wake up sources (CAN, LIN, WU1 to3 and wake up of μ C by timer) are disabled. After 1 sec, the voltage regulator tries to restart automatically. If the restart fails 7 times, within one minute, without clearing and thermal shutdown condition still exists, the L99PM62GXP enters the forced V_{BAT} standby Mode.

In case of short to GND at " V_1 " after initial turn on ($V_1 < 2V$ for $t > t_{V1short}$) the L99PM62GXP enters the forced V_{BAT} standby Mode. Reactivation (wake-up) of the device can be achieved with signals from CAN, LIN, WU1..3 or *periodic wake by timer* (see [Section 2.2.8: Timer interrupt / wake-up of microcontroller by timer](#)).

2.1.2 Voltage regulator: V_2

The voltage regulator V_2 can supply additional 5 V loads (e.g. logic components or the integrated HS CAN transceiver or external loads such as sensors or potentiometers). The maximum continuous load current is 100 mA. The regulator is protected against:

- Overload
- Overtemperature
- Short circuit (short to ground and battery supply voltage)
- Reverse biasing

2.1.3 Increased output current capability for voltage regulator V_2

For applications which require high output currents, the output current capability of the regulator can be increased by means of the integrated operational amplifiers and an external pass transistor.

Figure 3. Voltage source with external PNP

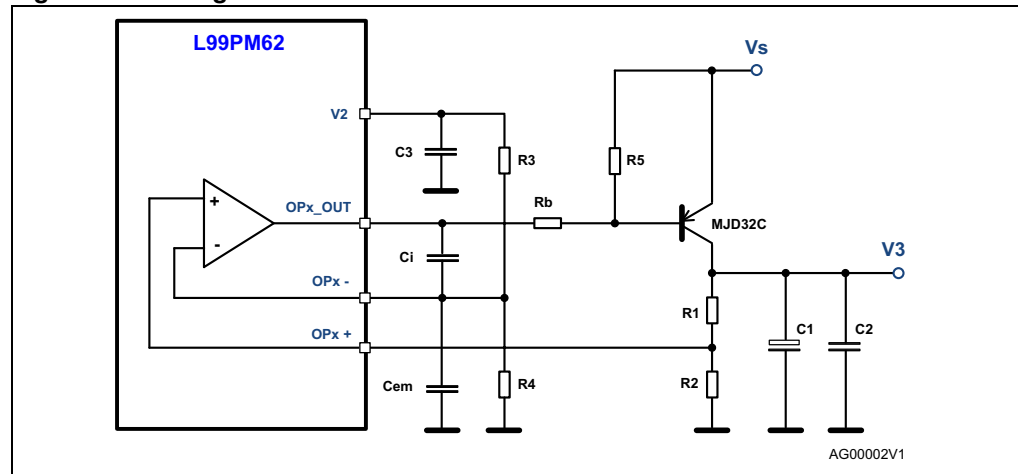

Figure 4. Voltage source with external PNP and current limitation

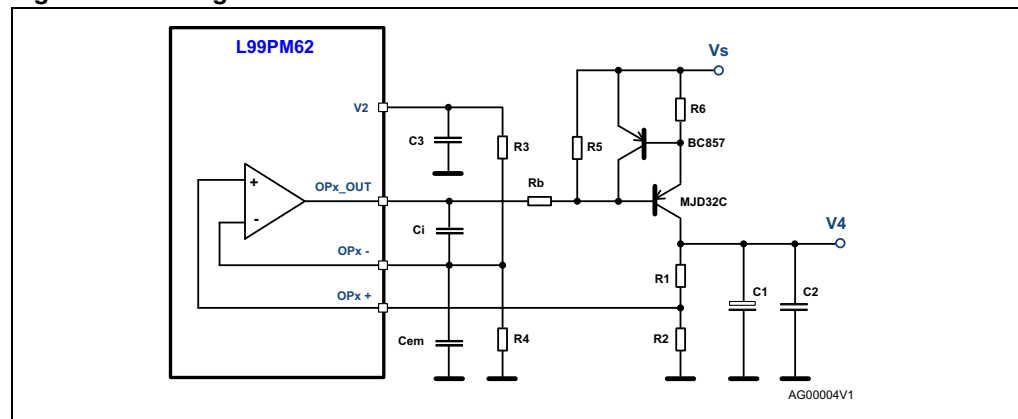

Figure 3 shows a possible configuration with a PNP pass element using voltage regulator 2 to provide the voltage reference for the regulated output voltage V_3 .

The V_S operating range for this circuit is 5.5 V to 18 V. It is important to respect the input common mode range specified for the operational amplifiers.

The output voltage V_3 can be calculated using the following formula:

$$V_3 = \frac{V_2}{2} \cdot \frac{R_1 + R_2}{R_2} [\text{V}]$$

The circuit in [Figure 4](#) provides additional current limitation using an additional PNP transistor and R_6 which allows setting the current limit.

Figure 5. Voltage source with external NPN

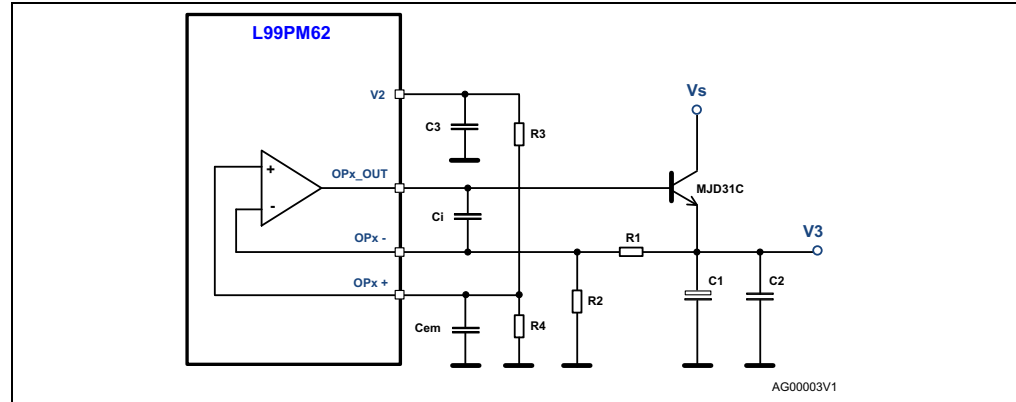
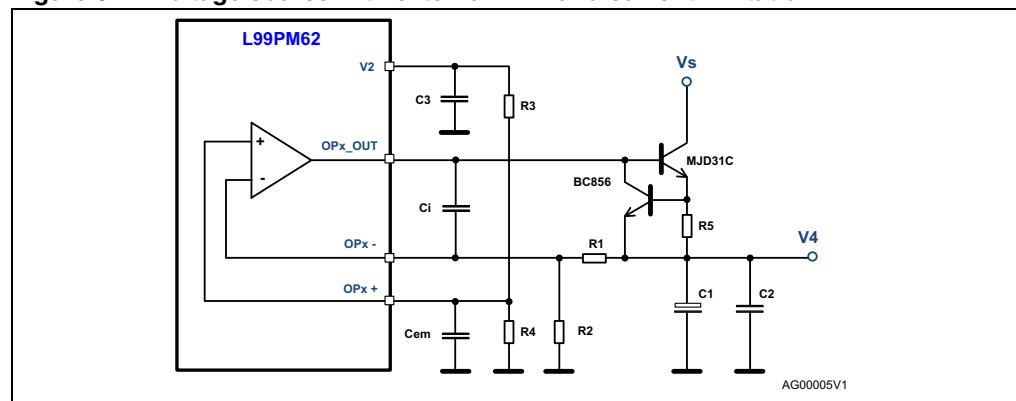

Figure 6. Voltage source with external NPN and current limitation



[Figure 5](#) shows a possible configuration with an NPN pass element using voltage regulator 2 to provide the voltage reference for the regulated output voltage V_3 . This circuit requires fewer components compared to the configuration in [Figure 3](#) but has a limited V_S operating range (6 V to 18 V).

The output voltage V_3 can be calculated using the following formula:

$$V_3 = \frac{V_2}{2} \cdot \frac{R_1 + R_2}{R_2} [\text{V}]$$

The circuit in [Figure 6](#) provides additional current limitation using an additional NPN transistor and R_5 which allows setting the current limit.

Alternatively, voltage regulator 1 can be used to provide the 5 V reference for this topology. However, the additional current consumption through R3 and R4 has to be considered in V_1 standby mode.

2.1.4 Voltage regulator failure

The V_1 , and V_2 regulator output voltages are monitored.

In case of a drop below the V_1 , V_2 – fail thresholds ($V_{1,2} < 2$ V, typ for $t > 2$ μ s), the $V_{1,2}$ -fail bits are latched. The fail bits can be cleared by a dedicated SPI command.

Short to ground detection

If 4 ms after turn on of the regulator the $V_{1,2}$ voltage is below the $V_{1,2}$ fail thresholds, (independent for $V_{1,2}$), the L99PM62GXP identifies a short circuit condition at the related regulator output and the regulator is switched off.

In case of V_1 short to GND failure the device enters V_{BAT} standby mode automatically. Bits Forced V_{BAT} STD2/SHTV₁ and V_1 fail were set.

In case of a V_2 short to GND failure the V_2 short and V_2 fail bit is set.

If the output voltage of the corresponding regulator once exceeded the $V_{1,2}$ fail thresholds the short to ground detection is disabled. If a short to ground condition occurs the regulator outputs switches off due to thermal shutdown (V_1 at TSD2; V_2 at TSD1).

2.1.5 Voltage regulator behaviour

Figure 7. Voltage regulator behaviour and diagnosis during supply voltage ramp-up / ramp-down conditions

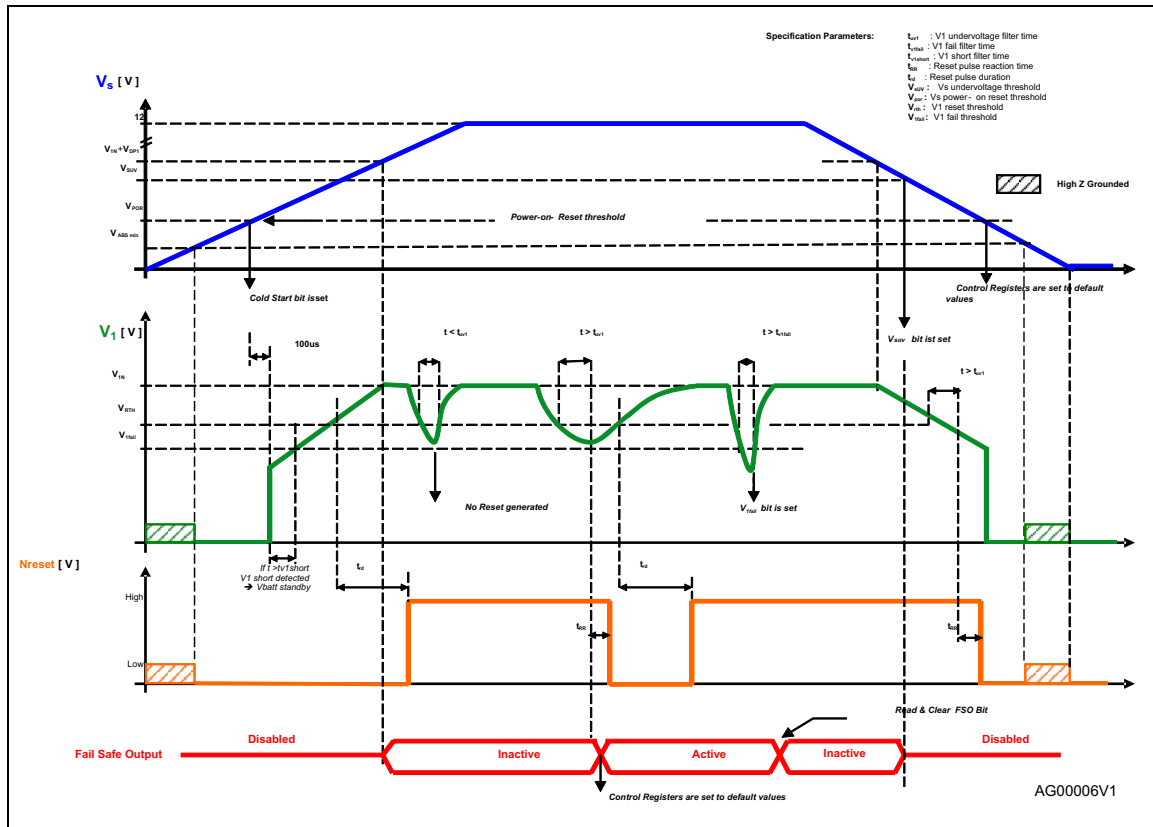

2.2 Operating modes

The L99PM62GXP can be operated in 4 different operating modes:

- Active
- Flash
- V_1 standby
- V_{BAT} standby

A cyclic monitoring of wake-up inputs and a periodic interrupt/wake-up by timer is available in standby modes.

2.2.1 Active mode

All functions are available and the device is controlled by the ST SPI Interface.

2.2.2 Flash mode

To program the system microcontroller, the L99PM62 can be operated in Flash mode where the internal watchdog is disabled. This mode can also be used for software debugging.

Except for the disabled watchdog, the Flash mode is identical to active mode and all device features are available.

A transition from Flash mode to V_{1stby} or $V_{batstby}$ is not possible.

The mode can be entered if one of the following conditions is applied:

- $V_{TxDL} \geq V_{Flash}$
- $V_{TxDC} \geq V_{Flash}$

At exit from Flash mode ($V_{TxD} < V_{Flash}$) no NReset pulse is generated and the watchdog starts with a long open window.

Note: Setting both TxDL and TxDC to high voltage levels ($> V_{Flash}$) is not allowed. Communication at the respective TxD pin is not possible.

2.2.3 V_1 standby mode

The transition from active mode to V_1 standby mode is controlled by SPI.

To supply the micro controller in a low power mode, the voltage regulator 1 (V_1) remains active. In order to reduce the current consumption, the regulator goes in low current mode as soon as the supply current of the microcontroller goes below the I_{cmp} current threshold. At this transition, the L99PM62 also deactivates the internal watchdog.

Relay outputs, LIN and CAN transmitters is switched off in V_1 standby mode. High-side outputs and the V_2 regulator remain in the configuration programmed prior to the standby command.

A cyclic supply of external contacts and a synchronized monitoring of the contact state can be activated and configured by SPI.

In V_1 standby mode various wake up sources can be individually programmed. Each wake up event puts the device into active mode and forces the RxDL/NINT pin to a low level indicating the wake-up condition to the microcontroller.

After power ON reset (POR) all wake up sources are activated by default except the periodic interrupt/wake timer.

With the interrupt timer the micro controller can be forced from 'stop' to 'run' after a programmable period. The RxDL/NINT pin is forced low after the timer is elapsed. The L99PM62GXP enters active mode and is awaiting a valid watchdog trigger.

Both internal timers can be used for this feature.

The interrupt timer (T_{INT}) at pin RxDL/NINT is only available in V_1 standby mode.

Note: Inputs TxDL, TxDC and CSN must be at high level or at high impedance in order to achieve minimum standby current in V_1 standby mode.

Inputs DI and CLK must be at GND or at high impedance to achieve minimum standby current in V_1 standby mode.

Interrupt

The interrupt signal (linked to RxDL/NINT internally) indicates a wake-up event from V_1 standby mode. In case of a wake-up by Wake-up Inputs, activity on LIN or CAN, SPI access or timer-interrupt the NINT pin is pulled low for 56 μ s.

In case of V_1 standby mode and ($I_{V1} > I_{cmp}$), the device remains in standby mode, the V_1 regulator switches to high current mode and the watchdog starts. No Interrupt signal is generated.

2.2.4 V_{BAT} standby mode

The transition from active mode to V_{BAT} standby mode is initiated by an SPI command.

In V_{BAT} standby mode, the V_1 voltage regulator, relay outputs, LIN and CAN transmitters are switched off. High-side outputs and the V_2 regulator remain in the configuration programmed prior to the standby command.

In V_{BAT} standby mode the current consumption of the L99PM62GXP is reduced to a minimum level.

Note: Inputs TXDL, TXDC and CSN must be terminated to GND in V_{BAT} standby to achieve minimum standby current.

This can be achieved with the internal ESD protection diodes of the microcontroller (microcontroller is not supplied in this mode; V_1 is pulled to GND).

2.2.5 Wake up from standby modes

A wake-up from standby mode switches the device to active mode. This can be initiated by one or more of the following events:

Table 3. Wake up sources

Wake up source	Description
LIN bus activity	Can be disabled by SPI
CAN bus activity	Can be disabled by SPI
Level change of WU1 - 3	Can be individually configured or disabled by SPI
$I_{V1} > I_{cmp}$	Device remains in V_1 standby mode but watchdog is enabled (If $I_{cmp} = 0$) and the V_1 regulator goes into high current mode (increased current consumption). No interrupt is generated.
Timer interrupt / wake up of μ C by TIMER	Programmable by SPI – V_1 standby mode: device wakes up and Interrupt signal is generated at RxDL/NINT when programmable time-out has elapsed – V_{BAT} standby mode: device wakes up, V_1 regulator is turned on and NReset signal is generated when programmable time-out has elapsed
SPI access	Always active (except in V_{BAT} standby mode) Wake up event: CSN is low and first rising edge on CLK

To prevent the system from a deadlock condition (no wake up possible) a configuration where the periodic timer interrupt and wake up by LIN and HS CAN are disabled, is not

allowed. The default configuration is entered for all wake-up sources in case of such an invalid setting.

All wake-up events from V_1 standby mode (except $I_{V1} > I_{comp}$) are indicated to the microcontroller by a low-pulse at RxDL/NINT (duration: 56 μ s).

Wake-up from V_1 standby by SPI Access might be used to check the interrupt service handler.

2.2.6 Wake-up inputs

The de-bounced digital inputs WU1 to WU3 can be used to wake up the L99PM62GXP from standby modes. These inputs are sensitive to any level transition (positive and negative edge)

For static contact monitoring, a filter time of 64 μ s is implemented at WU1-3. The filter is started when the input voltage passes the specified threshold.

In addition to the continuous sensing (static contact monitoring) at the wake up inputs, a cyclic sense functionality is implemented. This feature allows periodical activation of the wake-up inputs to read the status of the external contacts. The periodical activation can be linked to Timer1 or Timer2 (see [Section 2.2.7: Cyclic contact supply](#)). The input signal is filtered with a filter time of 16 μ s after a programmable delay (80 μ s or 800 μ s) according to the configured timer on-time. A wake-up is processed if the status has changed versus the previous cycle.

The outputs OUT_HS and OUT1-4 can be used to supply the external contacts with the timer setting according to the cyclic monitoring of the wake-up inputs.

If the wake-up inputs are configured for cyclic sense mode the input filter timing and input filter delay (WUx_filt in control register 2) must correspond to the setting of the high-side output which supplies the external contact switches (OUTx in control register 0).

In standby mode, the inputs WU1-3 are SPI configurable for pull-up or pull-down current source configuration according to the setup of the external. In active mode the inputs have a pull down resistor.

In active mode, the input status can be read by SPI (Status Register 2). Static sense should be configured (Control Register 2) before the read operation is started (In cyclic sense configuration, the input status is updated according to the cyclic sense timing; Therefore, reading the input status in this mode may not reflect the actual status).

2.2.7 Cyclic contact supply

In V_1 standby and V_{BAT} standby modes, any high-side driver output (OUT1..4, OUTHS) can be used to periodically supply external contacts.

The timing is selectable by SPI

Timer 1: period is X s. The on-time is 10 ms resp. 20 ms: With $X \in \{1, 2, 3, 4\}$

Timer 2: period is X ms. The on-time is 100 μ s resp. 1ms: With $X \in \{10, 20, 50, 200\}$ ms

2.2.8 Timer interrupt / wake-up of microcontroller by timer

During standby modes the cyclic wake up feature, configured via SPI, allows waking up the μ C after a programmable timeout according to timer1 or timer2.

From V_1 standby mode, the L99PM62GXP wakes up (after the selected timer has elapsed) and sends an interrupt signal (via RxDL/NINT pin) to the μ C. The device enters active mode and the watchdog is started with a long open window. The microcontroller can send the device back into V_1 standby after finishing its tasks.

From V_{BAT} standby mode, the L99PM62GXP wakes up (after the selected timer has elapsed), turns on the V_1 regulator and provides an NReset signal to the μ C. The device enters active mode and the watchdog is started with a long open window. The microcontroller can send the device back into V_{BAT} standby after finishing its tasks.

2.3 Functional overview (truth table)

Table 4. Functional overview (truth table)

Function	Comments	Operating modes		
		Active mode	V_1 -standby static mode (cyclic sense)	V_{BAT} -standby static mode (cyclic sense)
Voltage-regulator, V_1	$V_{OUT} = 5\text{ V}$	On	On ⁽¹⁾	Off
Voltage-regulator, V_2	$V_{OUT} = 5\text{ V}$	On/ Off (2)	On ⁽²⁾ / Off	On ⁽²⁾ / Off
Reset-generator		On	On	Off
Window watchdog	V_1 monitor	On	Off (On: $I_{V_1} > I_{cmp}$ -threshold and $I_{cmp} = 0$)	Off
Wake up		Off	Active ⁽³⁾	Active ⁽³⁾
HS-cyclic supply	Oscillator time base	On / Off	On ⁽²⁾ / Off	On ⁽²⁾ / Off
Relay driver		On	Off	Off
Operational amplifiers		On	Off	Off
LIN	LIN 2.1	On	Off ⁽⁴⁾	Off ⁽⁴⁾
HS_CAN		On	Off ⁽⁴⁾	Off ⁽⁴⁾
FSO (if configured by SPI), active by default	Fail safe output	OUT3/FSO Off ⁽⁵⁾	OUT3/FSO Off ⁽⁵⁾	OUT3/FSO Off ⁽⁵⁾
Oscillator		On	(6)	(6)
Vs-monitor		On	(7)	(7)

1. Supply the processor in low current mode.
2. Only active when selected via SPI.
3. Unless disabled by SPI.
4. The bus state is internally stored when going to standby mode. A change of bus state leads a wake-up after exceeding of internal filter time (if wake-up by LIN or CAN is not disabled by SPI).
5. ON in fail-safe condition: If Standby mode is entered with active Fail Safe mode, the output remains ON in Standby mode.
6. Activation = ON if cyclic sense is selected.
7. cyclic activation = pulsed ON during cyclic sense.

Figure 8. Operating modes

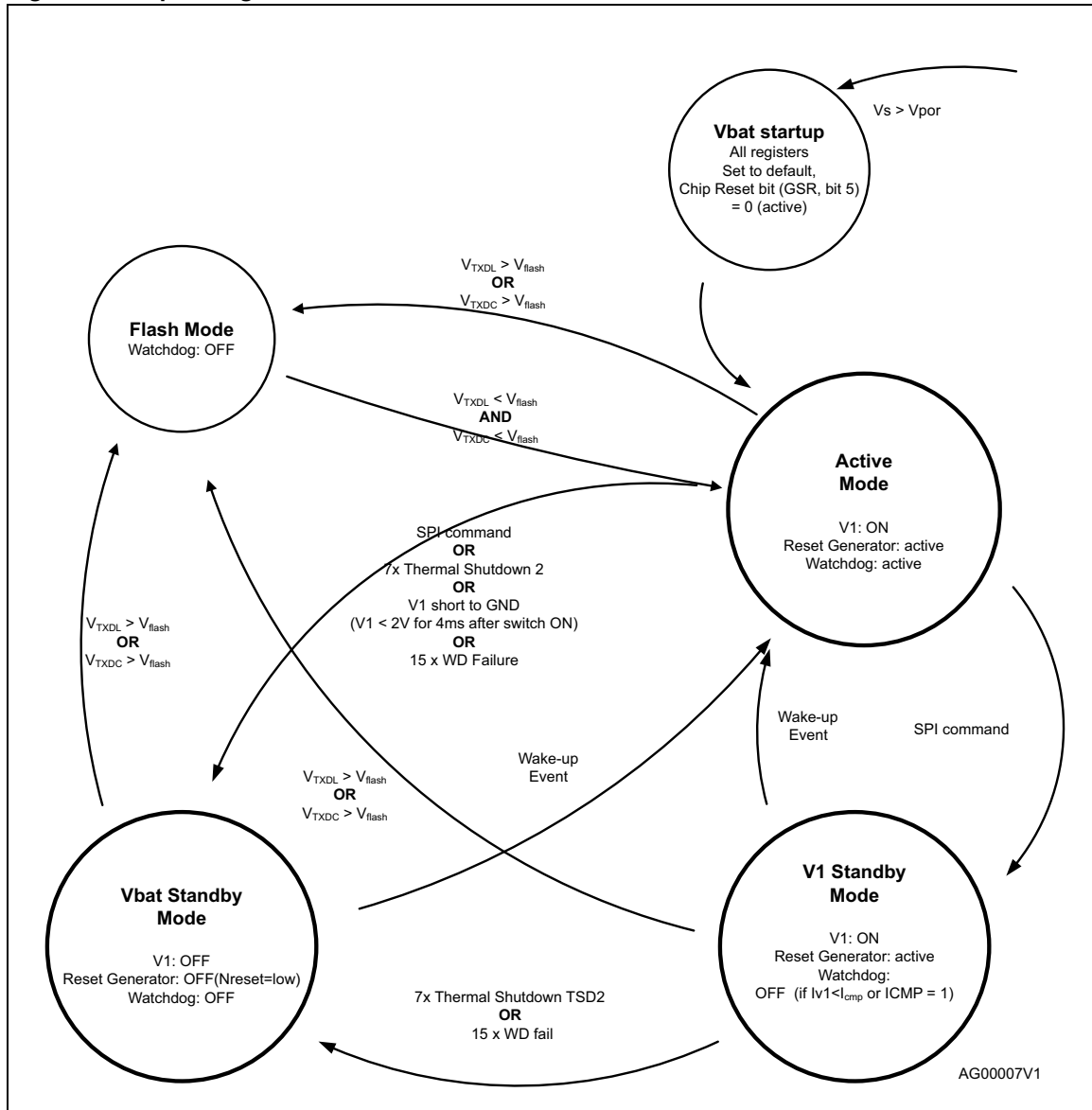

2.4 Configurable window watchdog

During normal operation, the watchdog monitors the micro controller within a programmable trigger cycle: (10 ms, 50 ms, 100 ms, 200 ms)

In V_{BAT} standby and Flash program modes, the watchdog circuit is automatically disabled. In V_1 standby mode a wake up by timer is programmable in order to wake up the μC (see [Section 2.2.8: Timer interrupt / wake-up of microcontroller by timer](#)). After wake-up, the watchdog starts with a long open window. After serving the watchdog, the μC may send the device back to V_1 standby mode.

After power-on or standby mode, the watchdog is started with a long open window (65 ms nominal). The long open window allows the micro controller to run its own setup and then to trigger the watchdog via the SPI. The trigger is processed when the CSN input becomes HIGH after the transmission of the SPI word.

Writing '1' to the watchdog trigger bit terminates the long open window and start the window watchdog (the timing is programmable by SPI). Subsequently, the micro controller has to serve the watchdog by alternating the watchdog trigger bit within the safe trigger area (refer to [Figure 29](#)). A correct watchdog trigger signal immediately starts the next cycle.

After 8 watchdog failures in sequence, the V_1 regulator is switched off for 200ms. If subsequently, 7 additional watchdog failures occur, the V_1 regulator is completely turned off and the device goes into V_{BAT} standby mode until a wakeup occurs.

In case of a watchdog failure, the outputs (RELx, OUTx, V_2) are switched off and the device enters fail-safe mode (i.e. all control registers are set to default values except the 'OUT3 control bit').

The following diagrams illustrate the watchdog behavior of the L99PM62. The diagrams are split into 3 parts. First diagram shows the functional behavior of the watchdog without any error. The second diagram covers the behavior covering all the error conditions, which can affect the watchdog behavior. Third diagram shows the transition in and out of Flash mode. All 3 diagrams can be overlapped to get all the possible state transitions under all circumstances. For a better readability, they were split in normal operating, operating with errors and Flash mode.

Figure 9. Watchdog in normal operating mode (no errors)

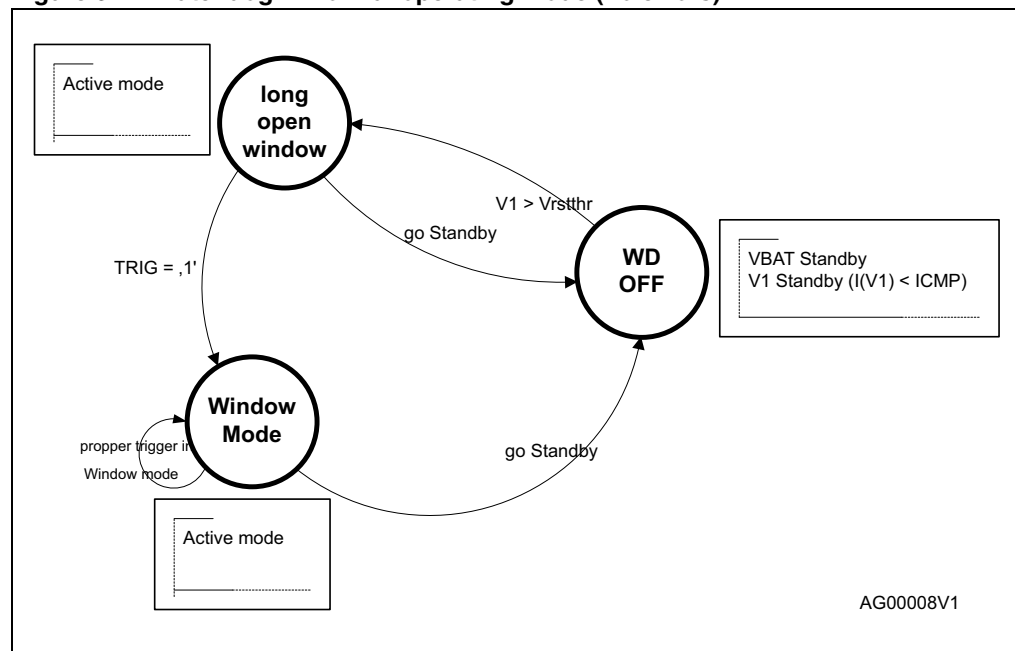

Figure 10. Watchdog with error conditions

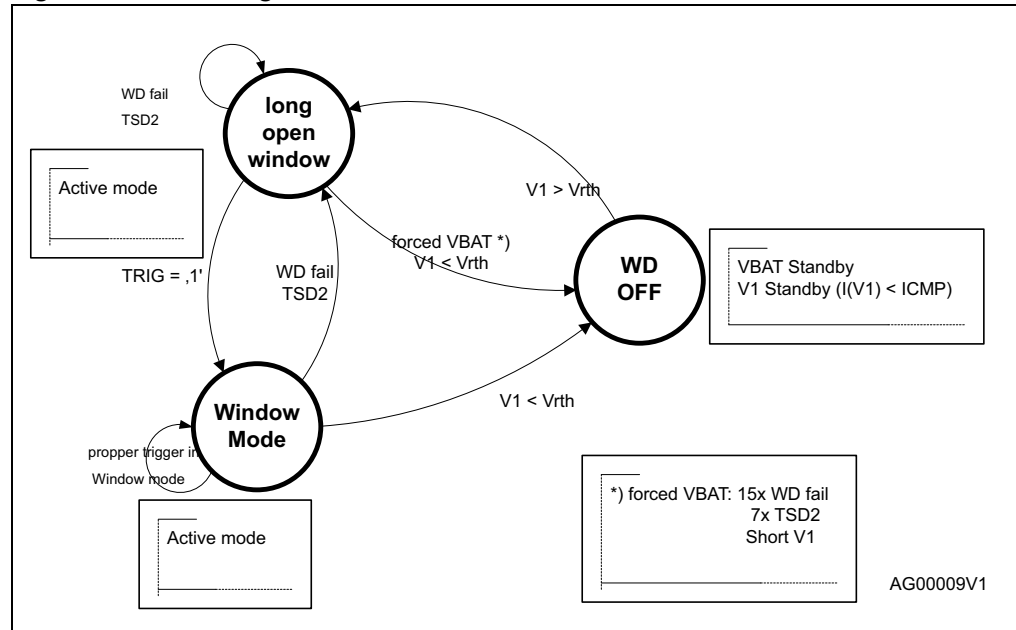
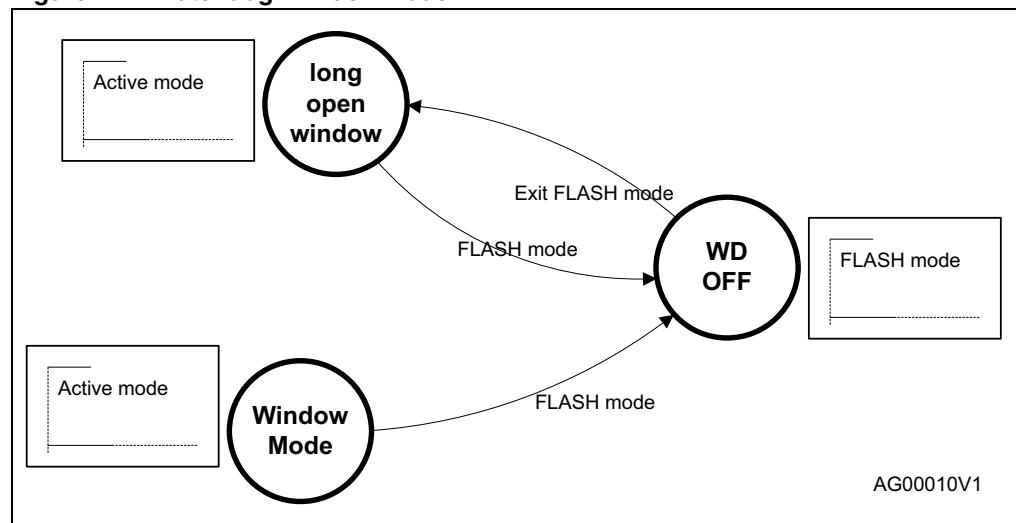

Figure 11. Watchdog in Flash mode



2.4.1 Change watchdog timing

There are 4 programmable watchdog timings available, which represent the nominal trigger time in window mode. To change the watchdog timing, a new timing has to be written by SPI. The new timing gets active with the next valid watchdog trigger. The following figures illustrate the sequence, which is recommended to use, changing the timing within long open window and within window mode.

Figure 12. Change watchdog timing within long open window

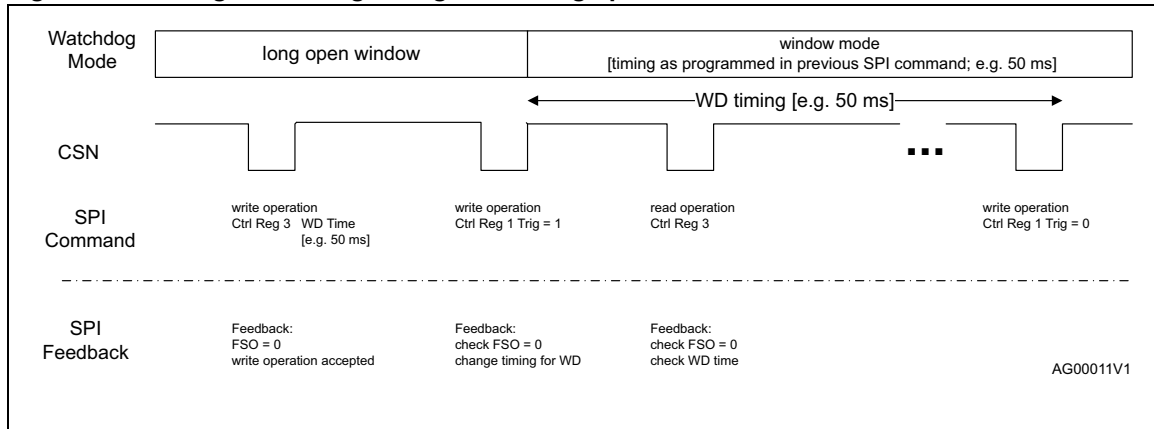
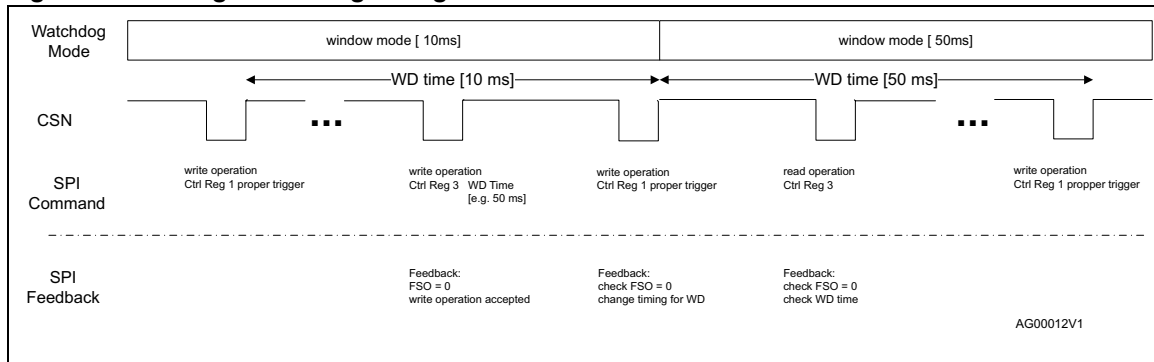

Figure 13. Change watchdog timing within window mode



If the device is in fail-safe mode, the control registers are locked for writing. To change the watchdog timing out of fail-safe mode, first the fail-safe condition must be solved, respective confirmed from the microcontroller. Afterwards the new watchdog timing can be programmed using the sequence from [Figure 14](#). Since the actions to remove, a fail-safe condition can differ from the root cause of the fail safe the following diagram shows the general procedure how to change the watchdog timing out of fail-safe mode. [Figure 15](#) shows the procedure to change watchdog timing with a previous watchdog failure, since this is a special fail-safe scenario.

Figure 14. General procedure to change watchdog timing out of fail safe mode

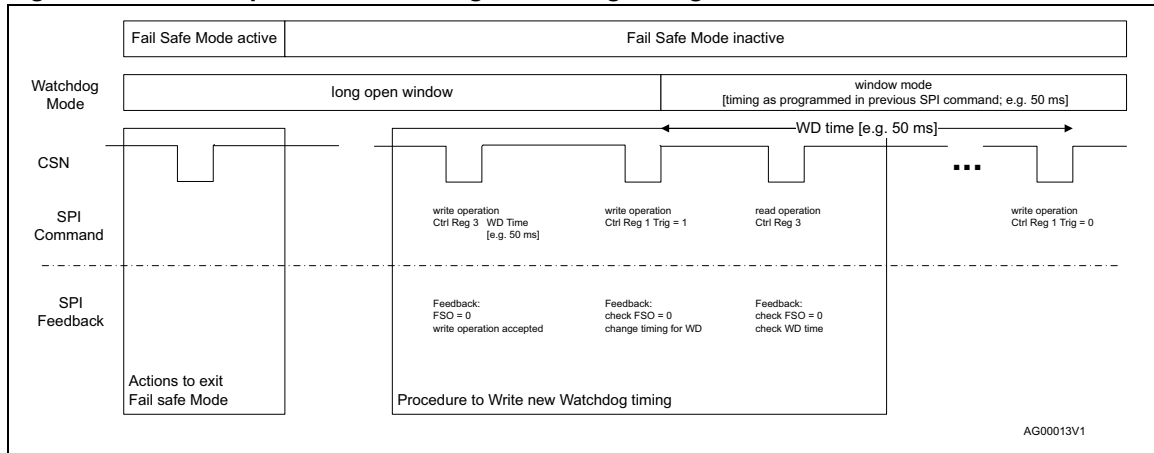
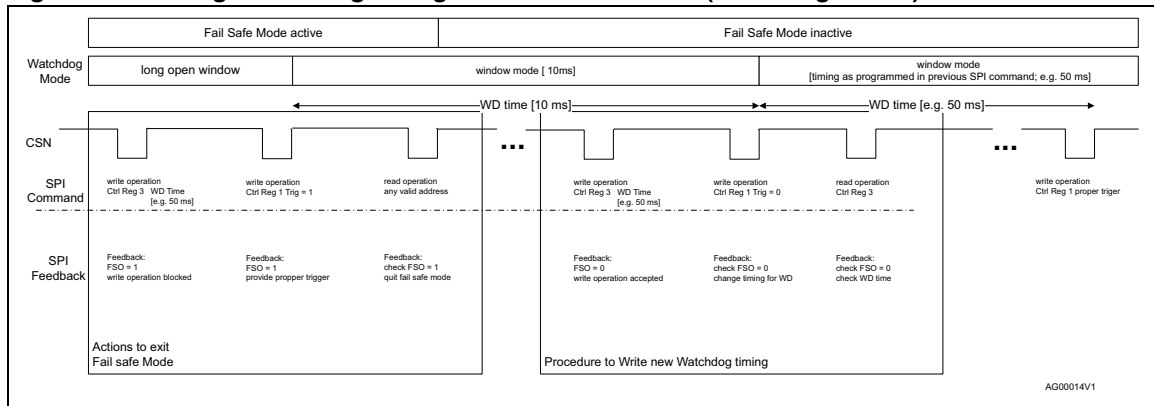

Figure 15. Change watchdog timing out of fail safe mode (watchdog failure)



2.5 Fail safe mode

2.5.1 Single failures

L99PM62GXP enters fail safe mode in case of:

- Watchdog failure
- V_1 turn on failure
 - V_1 short ($V_1 < V_{1fail}$ for $t > t_{V1short}$)
- V_1 undervoltage ($V_1 < V_{rth}$ for $t > t_{UV1}$)
- Thermal shutdown TSD2
- SPI failure
 - DI stuck to GND or V_{CC} (SPI frame = '00 00 00' or 'FF FF FF')

The fail safe functionality is also available in V_1 standby mode. During V_1 standby mode the fails safe mode is entered in the following cases:

- V_1 undervoltage ($V_1 < V_{rth}$ for $t > t_{UV1}$)
- Watchdog failure (if watchdog still running due to $I_{V1} > I_{cmp}$)
- Thermal shutdown TSD2

In fail safe mode the L99PM62 returns to a default. The fail safe condition is indicated to the remaining system in the global status register. The conditions during fails safe mode are:

- All outputs are turned off
- All control registers are set to default values (except OUT3/FSO configuration)
- Write operations to control registers are blocked until the fail safe condition is cleared (see [Table 5](#))
- LIN and HS CAN transmitter, OpAmps and SPI remain on
- Corresponding failure bits in status registers are set.
- FSO Bit (Bit 0 global status register) is set
- OUT3/FSO is activated if configured as fail safe output

If OUT3 is configured as FSO, the internal fail safe mode can be monitored at OUT3 (high-side driver is turned on in fail-safe mode). Self protection features for OUT3 when configured as FSO are active (see [Section 3.3: High-side driver outputs](#)).

OUT3 is configured as fail safe output by default. It can be configured to normal high-side driver operation by SPI. In this case, the configuration remains until V_s power on.

If the fail safe mode was entered it keeps active until the fail safe condition is removed and the fail safe was read by spi. depending on the root cause of the fail safe operation, the actions to exit fail safe mode are as shown in the following table.

Table 5. Fail safe conditions and exit modes

Failure source	Failure condition	Diagnosis	Exit from fail-safe mode
μC (oscillator)	Watchdog early write failure or expired window	Fail-safe = 1 WDfail = n+1	TRIG = 1 during LOWi and read fail-safe bit
V_1	Short at turn-on	Fail-safe = 1 Forced Sleep TSD2/SHTV ₁ = 1	Read&Clear SR3 after wake
	Undervoltage	Fail-safe = 1 $V_{1fail} = 1^{(1)}$	$V_1 > V_{rth}$ Read Fail-safe bit
Temperature	$T_j > TSD2$	Fail-safe = 1 TW = 1 TSD1 = 1 TSD2 = 1	$T_j < TSD2$ Read&Clear SR3
SPI	DI short to GND or V_{CC}	Fail-safe = 1	Valid SPI command

1. if $V_1 < V_{1fail}$ (for $t > t_{V1fail}$)
The fail-safe bit is located in the global status register (Bit 0).

2.5.2 Multiple failures – entering forced V_{BAT} standby mode

If the fail-safe condition persists and all attempts to return to normal system operation fail, the L99PM62 enters the *forced V_{BAT} standby mode* in order to prevent damage to the system. The *forced V_{BAT} standby mode* can be terminated by any regular wake-up event. The root cause of the *forced V_{BAT} standby* is indicated in the SPI status registers

The *forced V_{BAT} standby mode* is entered in case of:

- Multiple watchdog failures: forced sleep $WD = 1$ (15x watchdog failure)
- Multiple thermal shutdown 2: forced sleep $TSD2/SHTV1 = 1$ (7 x TSD2)
- V_1 short at turn-on: forced sleep $TSD2/SHTV1 = 1$ ($V_1 < V_{1fail}$ for $t > t_{V1fail}$)

Table 6. Persisting fail safe conditions and exit modes

Failure source	Failure condition	Diagnosis	Exit from fail-safe mode
μC (oscillator)	15 consecutive watchdog failures	Fail-safe = 1 ForcedSleepWD = 1	Wake-up TRIG = 1 during LOWi read & clear SR3
V_1	short at turn-on	Fail-safe = 1 ForcedSleepTSD2/SHTV ₁ = 1	Read&clear SR3 after wake-up
Temperature	7 times TSD2	Fail-safe = 1 TW = 1 TSD1 = 1 TSD2 = 1 ForcedSleepTSD2/SHTV ₁ = 1	Read&clear SR3 after wake-up

Figure 16. Example: exit fail safe mode from watchdog failure

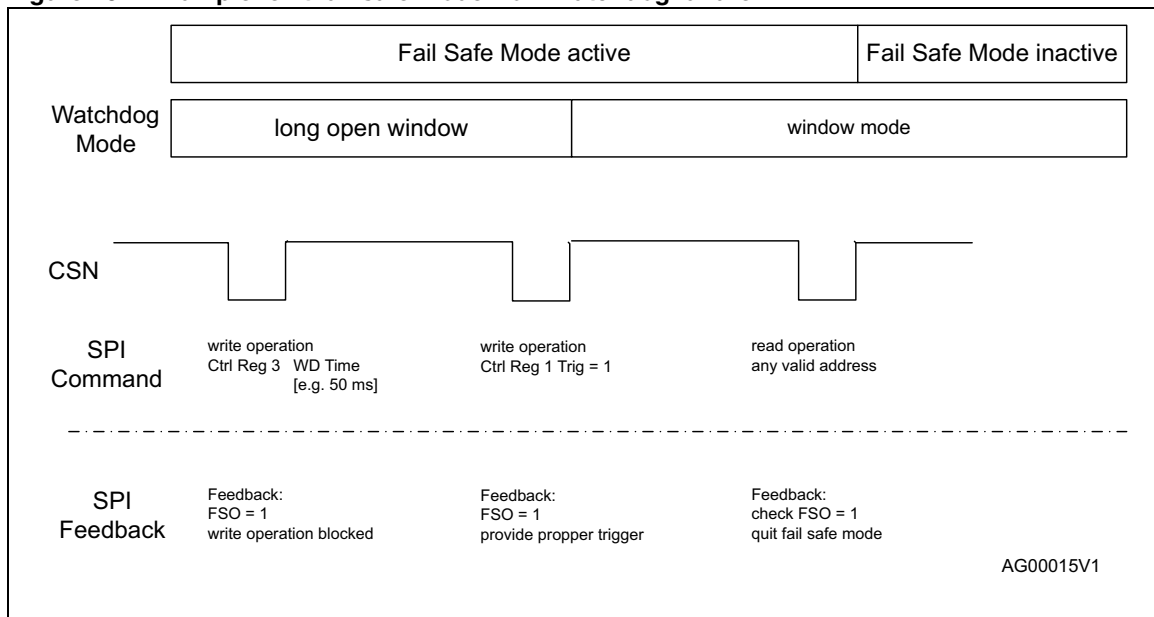

2.6 Reset output (NRESET)

If V_1 is turned on and the voltage exceeds the V_1 reset threshold, the reset output "NRESET" is pulled up by internal pull up resistor to V_1 voltage after a reset delay time (t_{rd}). This is necessary for a defined start of the micro controller when the application is switched on. Since the NRESET output is realized as an open drain output it is also possible to connect an external NRESET open drain NRESET source to the output. It must be considered that as soon the NRESET is released from the L99PM62 the Watchdog timing starts.

A reset pulse is generated in case of:

- V_1 drops below V_{rth} (configurable by SPI) for $t > t_{UV1}$
- Watchdog failure

Note: An external pull-up resistor ($1k\Omega$) to V_1 is recommended in order to ensure $I_{LOAD1} > I_{cmp}$ during reset condition

2.7 Operational amplifiers

The operational amplifiers are especially designed to be used for sensing and amplifying the voltage drop across ground connected shunt resistors. Therefore the input common mode range includes -0.2 V to 3 V.

The operational amplifiers are designed for -0.2 V to +3 V input voltage swing and rail-to-rail output voltage range.

All pins (positive, negative and outputs) are available to be able to operate in non-inverting and inverting mode. Both operational amplifiers are on-chip compensated for stability over the whole operating range within the defined load impedance.

The operational amplifiers may also be used to setup an additional high current voltage source with an external pass element. Refer to [Section 2.1.3](#) for a detailed description.

2.8 LIN bus interface

Features

- Speed communication up to 20 kbit/s.
- LIN 2.1 compliant (SAEJ2602 compatible) transceiver.
- Function range from +40 V to -18 V DC at LIN pin.
- GND disconnection fail safe at module level.
- Off mode: does not disturb network.
- GND shift operation at system level.
- Micro controller Interface with CMOS compatible I/O pins.
- Internal pull up resistor.
- Internal high-side switch to disconnect master pull-up resistor in case of short circuit of bus signal.
- ESD and transient immunity according to ISO7637 and EN / IEC61000-4-2.
- Matched output slopes and propagation delay.

In order to further reduce the current consumption in standby mode, the integrated LIN bus interface offers an ultra low current consumption.

Note: Use of master pull-up switch is optional.

2.8.1 Error handling

The L99PM62GXP provides the following 3 error handling features which are not described in the LIN Spec. V_{2.1}, but are realized in different stand alone LIN transceivers / micro controllers to switch the application back to normal operation mode.

At $V_S > V_{por}$ (i.e. V_S power-on reset threshold), the LIN transceiver is enabled. The LIN transmitter is disabled in case of the following errors:

- Dominant TxDL time out
- LIN permanent recessive
- Thermal shutdown 1
- V_S over/undervoltage
- The LIN receiver is not disabled in case of any failure condition.

Dominant TxDL time out

If TXDL is in dominant state (low) for more than 12 ms (typ) the transmitter is disabled, the status bit is latched and can be read and optionally cleared by SPI. The transmitter remains disabled until the status register is cleared. This feature can be disabled via SPI.

Permanent recessive

If TXDL changes to dominant (low) state but RXDL signal does not follow within 40 μ s the transmitter is disabled, the status bit is latched and can be read and optionally cleared by SPI. The transmitter remains disabled until the status register is cleared.

Permanent dominant

If the bus state is dominant (low) for more than 12 ms a permanent dominant status is detected. The status bit is latched and can be read and optionally cleared by SPI. The transmitter is not disabled.

2.8.2 Wake up (from LIN)

In standby mode the L99PM62GXP can receive a wake up from LIN bus. For the wake up feature the L99PM62GXP logic differentiates two different conditions.

Normal wake up

Normal wake up can occur when the LIN transceiver was set in standby mode while LIN was in recessive (high) state. A dominant level at LIN for t_{inbus} , switches the L99PM62GXP to active mode.

Wake up from short to GND condition

If the LIN transceiver was set in standby mode while LIN was in dominant (low) state, recessive level at LIN for t_{inbus} , switches the L99PM62GXP to active mode.

Note: A wake up caused by a message on the bus starts the voltage regulator and the microcontroller to switch the application back to normal operation mode.

2.8.3 LIN pull-up

The master node pull-up resistor (1 k Ω) can be connected to V_S using the internal LIN_PU high-side switch. This high-side switch can be controlled by SPI in order to allow disconnection of the pull-up resistor in case of LIN bus short to GND conditions.

Figure 17. LIN master node configuration using LIN_PU (optional)

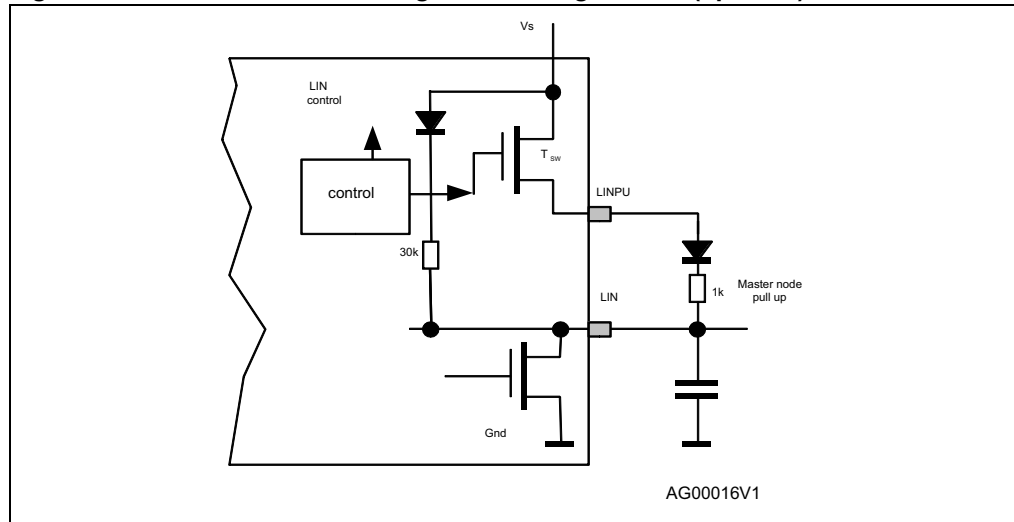

LIN_PU high-side driver characteristics:

- Activated by default and can be turned off by SPI command (CR4).
- Remains active in standby modes.
- Switch off only in case of over temperature (TSD2 = thermal shutdown #2).
- No over current protection.
- Typical R_{DSon} , 10 Ω .

2.9 High speed CAN bus transceiver

General requirements

- Communication speed up to 1 Mbit/s.
- ISO 11898-2 and ISO 11898-5 compliant
- SAE J2284 compliant
- Function range from -27 V to +40 V DC at CAN pins.
- GND disconnection fail safe at module level.
- GND shift operation at system level.
- Micro controller Interface with CMOS compatible I/O pins.
- ESD and transient immunity according to ISO7637 and EN / IEC61000-4-2
- Matched output slopes and propagation delay
- Split output pin for stabilizing the recessive bus level
- Receive-only mode available

In order to further reduce the current consumption in standby mode, the integrated CAN bus interface offers an ultra low current consumption.

2.9.1 CAN error handling

The L99PM62GXP provides the following 4 error handling features which are not described in the ISO 11898-2/ISO 11898-5, but are realized in different stand alone CAN transceivers/micro controllers to switch the application back to normal operation mode.

At $V_S > V_{por}$ (i.e. V_S power-on reset threshold), the CAN transceiver is enabled. It remains enabled also in case of V_S overvoltage and undervoltage conditions.

The CAN transmitter is disabled only in case of the following errors:

- Dominant TxDC time out
- CAN permanent recessive
- RxDC permanent recessive
- Thermal shutdown 1

The CAN receiver is not disabled in case of any failure condition.

Dominant TxDC time out

If TXDC is in dominant state (low) for $t > t_{dom(TxD)}$ the transmitter is disabled, status bit is latched and can be read and optionally cleared by SPI. The transmitter remains disabled until the status register is cleared.

CAN permanent recessive

If TXDC changes to dominant (low) state but CAN bus does not follow for 4 times, the transmitter is disabled, status bit is latched and can be read and optionally cleared by SPI. The transmitter remains disabled until the status register is cleared.

CAN permanent dominant

If the bus state is dominant (low) for $t > t_{CAN}$ a permanent dominant status is detected. The status bit is latched and can be read and optionally cleared by SPI. The transmitter is not disabled.

RXDC permanent recessive

If RXDC pin is clamped to recessive (high) state, the controller is not able to recognize a bus dominant state and could start messages at any time, which results in disturbing the overall bus communication. Therefore, if RXDC does not follow TXDC for 4 times the transmitter is disabled. The status bit is latched and can be read and optionally cleared by SPI. The transmitter remains disabled until the status register is cleared.

2.9.2 Wake up (from CAN)

When the L99PM62GXP is in standby mode with CAN wake up option enabled, the CAN bus traffic is detected. For the wake up feature the L99PM62GXP logic differentiates different conditions. During V_1 Standby mode RXDC output is kept at recessive level. Independent from the wakeup pattern selected and independent from the previous Standby mode, the RXDC reflect immediately the bus state after the wakeup. This feature allows implementation of a 'partial networking' functionality controlled by the system microcontroller.

Normal pattern wake up

Normal pattern wake up can occur when CAN pattern wake up option is enabled and the CAN transceiver was set in standby mode while CAN bus was in recessive (high) state or dominant (low) state. In order to wake up the L99PM62GXP, the following criteria must be fulfilled:

- The CAN interface wake-up receiver must receive a series of two consecutive valid dominant pulses, each of which must be longer than 2 μ s
- The distance between 2 pulses must be longer than 2 μ s.
- The two pulses must occur within a time frame of 1.0 ms

Wake up from short to GND condition

Even if CAN pattern wake up option is enabled, but the CAN transceiver was set in standby mode after a qualified permanent dominant state, recessive level at CAN, switches the L99PM62GXP to active mode.

No pattern wake up

If the CAN pattern wake up option is disabled, any transition either dominant (low) state to recessive (high) state or recessive (high) state to dominant (low) state switches the L99PM62GXP to active mode (after a filtering time of 2 μ s).

Note: A wake up caused by a message on the bus starts the voltage regulator and the microcontroller to switch the application back to normal operation mode.

Figure 18. CAN wake up capabilities

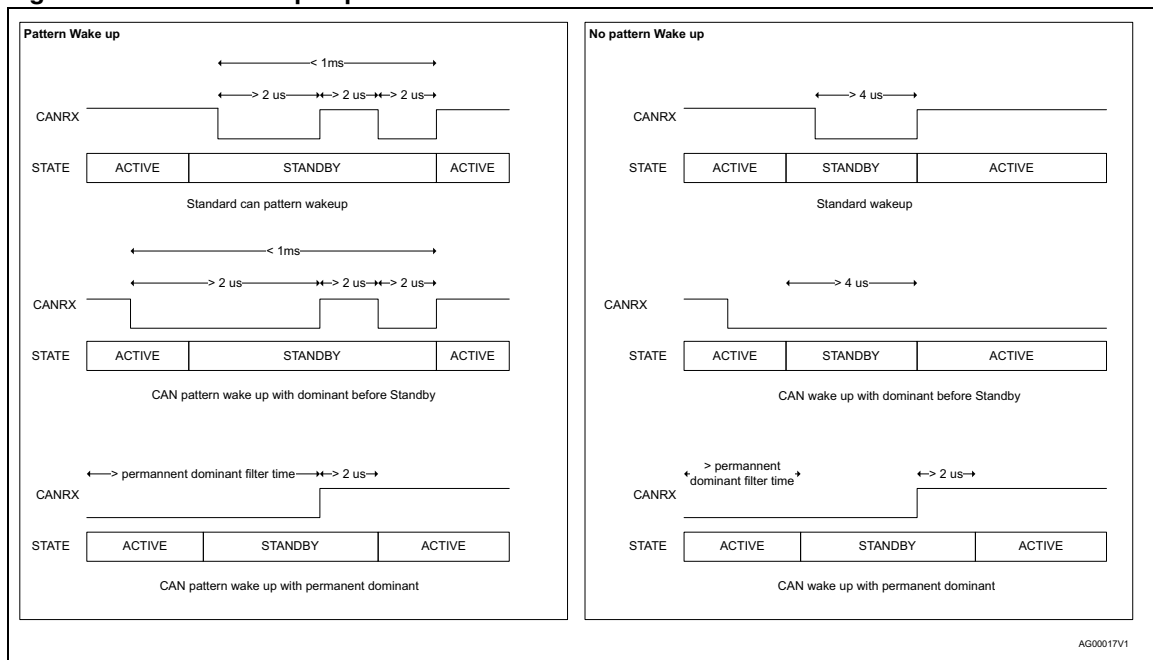

Note: Pictures above illustrate the wake up behaviour from V_1 standby mode. For wake up from V_{BAT} standby mode an NReset pulse is generated instead of the RXDL (Interrupt) signal.

2.9.3 CAN sleep mode

During active mode it is possible to deactivate the CAN transceiver with a dedicated SPI command (CR4, CAN_act = 0). The CAN transceiver remains deactivated until it is activated again. With a deactivated CAN the receiver input termination network is disconnected from the bus and the CANH, CANL bus lines is driven to GND. The SPLIT output is also deactivated in this case.

2.9.4 CAN receive only mode

With the CAN_rec_only bit in control register 4 it is possible to disable the CAN transmitter in active mode. In this mode it is possible to listen to the bus but not sending to it. The receiver termination network is still activated in this mode.

2.9.5 CAN looping mode

If the CAN_Loop_en bit in control register 4 is set the TXDC input is mapped directly to the RXDC pin. This mode can be used in combination with the CAN receive only mode, to run diagnosis for the CAN protocol handler of the micro controller.

2.10 Serial peripheral interface (ST SPI standard)

A 24 bit SPI is used for bi-directional communication with the micro controller.

During active mode, the SPI

- Triggers the watchdog
- Controls the modes and status of all L99PM62GXP modules (incl. input and output drivers)
- Provides driver output diagnostic
- Provide L99PM62GXP diagnostic (incl. overtemperature warning, L99PM62GXP operation status)

The SPI can be driven by a micro controller with its SPI peripheral running in following mode:

CPOL = 0 and CPHA = 0.

For this mode input data is sampled by the low to high transition of the clock CLK, and output data is changed from the high to low transition of CLK.

This device is not limited to micro controller with a built-in SPI. Only three CMOS-compatible output pins and one input pin is needed to communicate with the device. A fault condition can be detected by setting CSN to low. If CSN = 0, the DO-pin reflects the global error flag (fault condition) of the device.

Chip select not (CSN)

The input pin is used to select the serial interface of this device. When CSN is high, the output pin (DO) is in high impedance state. A low signal activates the output driver and a serial communication can be started. The state during CSN = 0 is called a communication frame.

If CSN = low for $t > t_{CSNfail}$ the DO output is switched to high impedance in order to not block the signal line for other SPI nodes.

Serial data in (DI)

The input pin is used to transfer data serial into the device. The data applied to the DI is sampled at the rising edge of the CLK signal and shifted into an internal 24 bit shift register. At the rising edge of the CSN signal the contents of the shift register is transferred to Data Input Register. The writing to the selected data input register is only enabled if exactly 24 bits are transmitted within one communication frame (i.e. CSN low). If more or less clock pulses are counted within one frame the complete frame is ignored. This safety function is implemented to avoid an activation of the output stages by a wrong communication frame.

Note: Due to this safety functionality a daisy chaining of SPI is not possible. Instead, a parallel operation of the SPI bus by controlling the CSN signal of the connected IC's is recommended.

Serial data out (DO)

The data output driver is activated by a logical low level at the CSN input and goes from high impedance to a low or high level depending on the global error flag (fault condition). The first rising edge of the CLK input after a high to low transition of the CSN pin transfers the content of the selected status register into the data out shift register. Each subsequent falling edge of the CLK shifts the next bit out.

Serial clock (CLK)

The CLK input is used to synchronize the input and output serial bit streams. The data input (DI) is sampled at the rising edge of the CLK and the data output (DO) changes with the falling edge of the CLK signal. The SPI can be driven with a CLK Frequency up to 1MHz.

3 Protection and diagnosis

3.1 Power supply fail

Over and under-voltage detection on V_s

3.1.1 V_s overvoltage

If the supply voltage V_s reaches the over voltage threshold (V_{SOV}):

- Outputs OUTx, RELx and LIN are switched to high impedance state (load protection). CAN is not disabled. Recovery of outputs when the overvoltage condition disappears is depending on the setting of VLOCKOUT_EN bit in Control Register 4.
 - VLOCKOUT_EN = 1: Outputs are off until read and clear SR3.
 - VLOCKOUT_EN = 0: Outputs switch automatically on when overvoltage condition disappears.
- The over voltage bit is set and can be cleared with a 'Read and Clear' command. The overvoltage bit is removed automatically if VLOCKOUT_EN = 0 and the overvoltage condition disappears.
- Outputs REL1,2 can be excluded from a shutdown in case of overvoltage by SPI (LSOVUV_Shutdown_en in CR4)

3.1.2 V_s undervoltage

If the supply voltage V_s drops below the under voltage threshold voltage (V_{SUV})

- Outputs OUTx, RELx and LIN are switched to high impedance state (load protection). CAN is not disabled. Recovery of outputs when the undervoltage condition disappears is depending on the setting of VLOCKOUT_EN bit.
 - VLOCKOUT_EN = 1: Outputs are off until read and clear SR3.
 - VLOCKOUT_EN = 0: Outputs switch on automatically when undervoltage condition disappears.
- The undervoltage bit is set and can be cleared with a 'Read and Clear' command. The undervoltage bit is removed automatically if VLOCKOUT_EN = 0 and the undervoltage condition disappears
- Outputs REL1,2 can be excluded from a shutdown in case of undervoltage by SPI (LSOVUV_shutdown_en in CR4)

Figure 19. Over voltage and under voltage protection and diagnosis

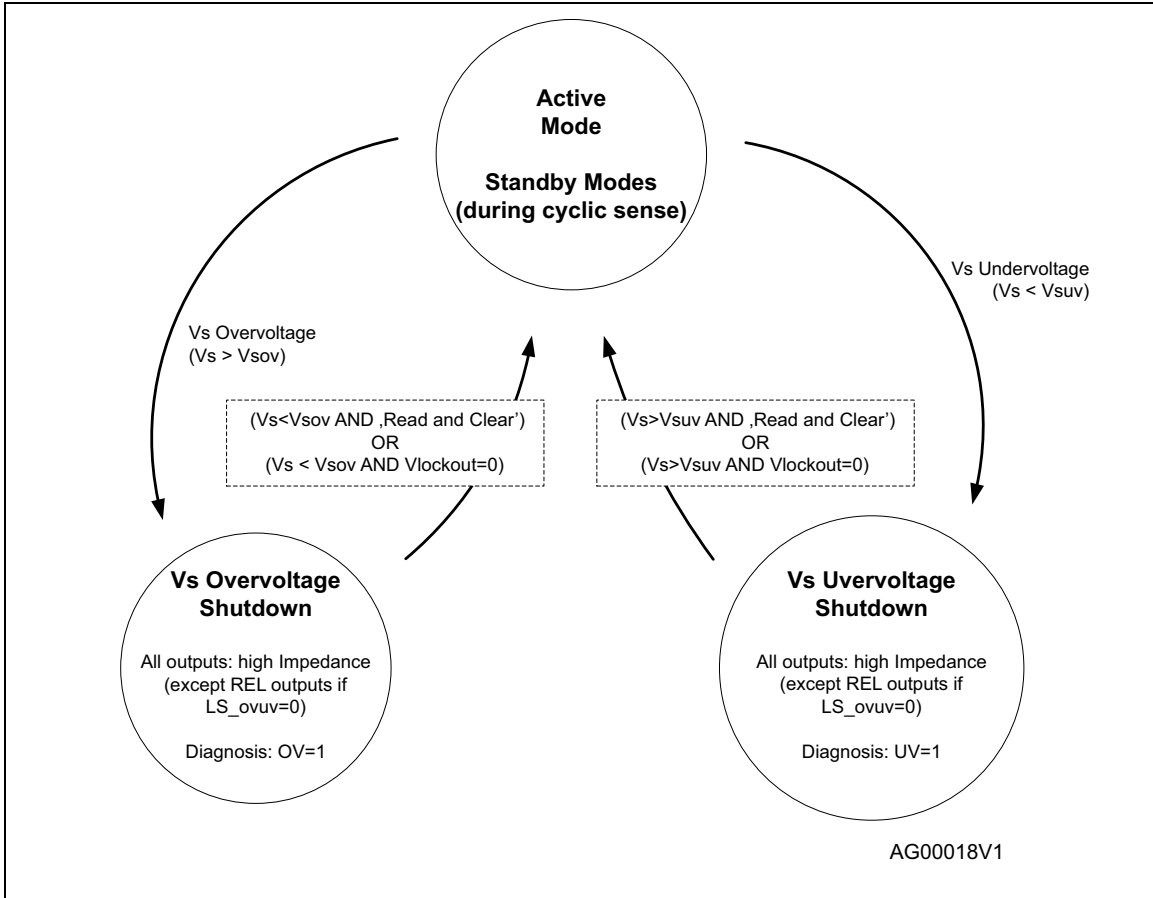

3.2 Temperature warning and thermal shutdown

Figure 20. Thermal shutdown protection and diagnosis

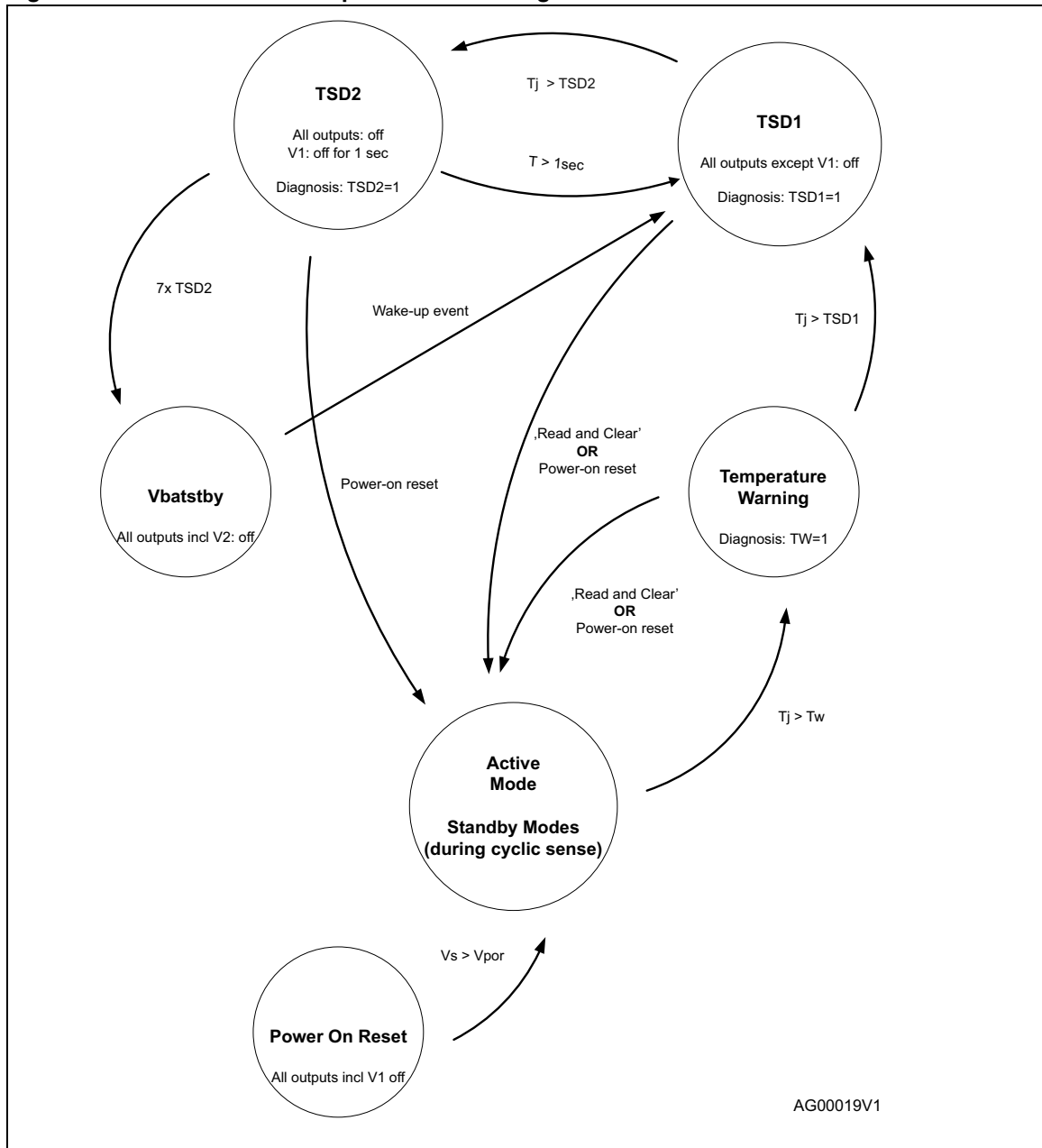

Note: The thermal state machine recovers the same state were it was before entering standby mode. In case of a TSD2 it enters TSD1 state.

3.3 High-side driver outputs

The component provides a total of 4 high-side outputs Out1 to 4, (7 Ω typical at 25°C) to drive e.g. LED's or hall sensors and 1 high-side output OUT_HS with 1 Ω typical at 25 °C).

The high-side outputs switch off in case of:

- V_S over and undervoltage
- Overcurrent
- Overtemperature (TSD1) with pre warning^(a)

In case of overload or over temperature (TSD1) condition, the drivers switches off. The according status bit is latched and can be read and optionally cleared by SPI. The drivers remain off until the status is cleared.

In case over/under voltage condition, the drivers is switched off. The according status bit is latched and can be read and optionally cleared by SPI. If the Vlockout bit (Control Register 4) is set to '1' the drivers remain off until the status is cleared. If the Vlockout bit is set to '0' the drivers switches on automatically if the error condition disappears.

In case of open-load condition, the according status register is latched. The status can be read and optionally cleared by SPI. The high-sides are not switched off.

For OUT_HS the auto recovery feature (OUTHSSREC bit Control Register 4) can be enabled. If this bit is set to '1' the driver is automatically restart from a overload condition. This overload recovery feature is intended for loads which have an initial current higher than the over current limit of the output (e.g. Inrush current of cold light bulbs). During auto recovery mode the over current status bit can not be read from SPI.

The device itself can not distinguish between a real overload and a non linear load like a light bulb. A real overload condition can only be qualified by time. As an example, the micro controller can switch on light bulbs by setting the over current recovery bit for the first 50ms. After clearing the recovery bit, the output is automatically disabled if the overload condition still exists.

In case of a fail safe condition, the high-side drivers are switched off. The control bits are set to default values. (except OUT3/FSO if it is used as a high-side driver output)

Note: *The maximum voltage and current applied to the high-side outputs is specified in [Section 5.1: Absolute maximum rating](#). Appropriate external protection may be required in order to respect these limits under application conditions.*

Each high-side driver can be driven whether with a PWM signal or with a internal Timer. See [Table 7](#).

For more Details please refer to [Section 6.2: SPI registers](#).

Table 7. PWM configuration for high-side outputs

High-side output	PWM channel	Internal timer
OUT1	PWM 1	Timer 1
OUT2	PWM 2	Timer 2
OUT3	PWM 3	-

a. Except OUT3 when configured as FSO.

Table 7. PWM configuration for high-side outputs (continued)

High-side output	PWM channel	Internal timer
OUT4	PWM 4	Timer 2
OUTHS	PWM 3 / PWM 4	Timer 1 / Timer 2

The PWM 1 / 3 channels start a PWM period with the ON phase, while the PWM 2 / 4 channels start with the OFF phase. In this way it is possible to use the 4 PWM channels in a phase shifted way.

The [Figure 21](#) shows this feature with a duty cycle of 25% for both PWM channels.

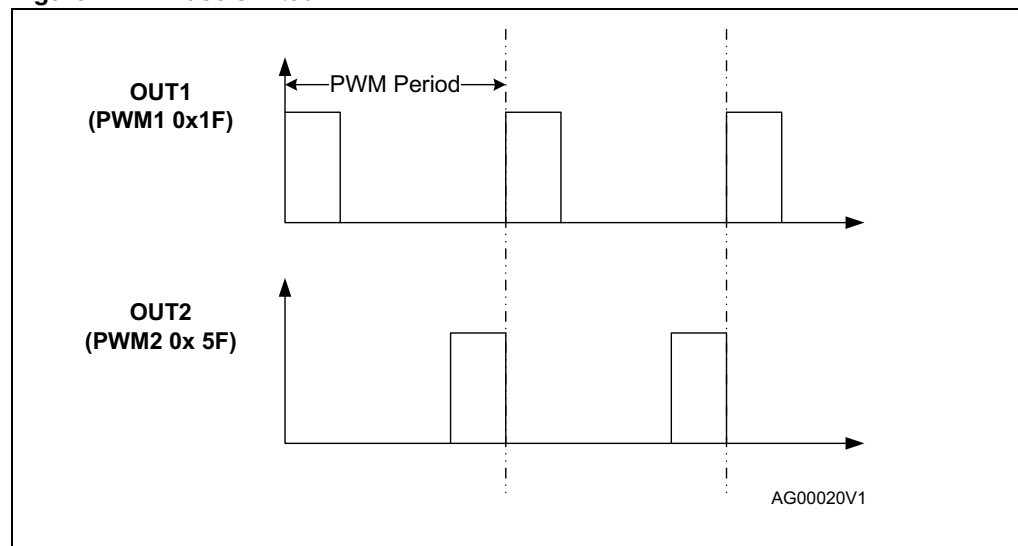
Figure 21. Phase shifted PWM

3.4 Low-side driver outputs REL1, REL2

The outputs REL1, REL2 ($R_{DSon} = 2 \Omega$ typical at 25 °C) are specially designed to drive relay loads.

The outputs provide an active output zener clamping (45 V typical) feature for the demagnetization of the relay coil, even though a load dump condition exists.

For fail-safe reasons the relay drivers are linked with the fail safe operation: in case of entering the fail safe mode, the relay drivers switches off and the SPI control bits are set to default (i.e. driver is off).

The low-side drivers switch off in case of:

- V_S over and undervoltage
- Overcurrent
- Overtemperature with pre warning

In case of overload or overtemperature (TSD1) condition, the drivers switches off. The according status bit is latched and can be read and optionally cleared by SPI. The drivers remain off until the status is cleared.

In case V_S over/undervoltage condition, the drivers is switched off. The according status bit is latched and can be read and optionally cleared by SPI. If the Vlockout bit (Control Register 4) is set to '1' the drivers remain off until the status is cleared. If the Vlockout bit is set to '0' the drivers is switched on automatically if the error condition disappears.

With the LSOVUV_shutdown_en bit (Control Register 4) the drivers can be excluded from a switch off in case of V_S over/undervoltage. If the bit is set to '1' the driver switches off, otherwise the drivers remain on.

3.5 SPI diagnosis

Digital diagnosis features are provided by SPI (for details please refer to [Section 6.2: SPI registers](#)).

- V_1 reset threshold programmable
- Overtemperature including. pre warning
- Open-load separately for each output stage except REL1/REL2
- Overload status separately for each output stage
- V_S -supply over/under voltage
- V_1 and V_2 fail bit
- V_2 output short to GND
- Status of the WU1 to 3
- Wake-up sources (CAN, LIN, SPI, Timer, WU1...3)
- chip reset bit (start from power-on reset)
- Number of unsuccessful V_1 restarts after thermal shutdown
- Number of sequential watchdog failures
- LIN diagnosis (permanent recessive/dominant, dominant TxD)
- CAN diagnosis (permanent recessive/dominant, dominant TxD, recessive RXD)
- Device State (wake-up from V_1 standby or V_{BAT} standby)
- Forced V_{BAT} standby after WD-fail, forced V_{BAT} standby after overtemperature
- Watchdog timer state (diagnosis of watchdog)
- Fail-safe status
- SPI communication error

4 Typical application

Figure 22. Typical application diagram

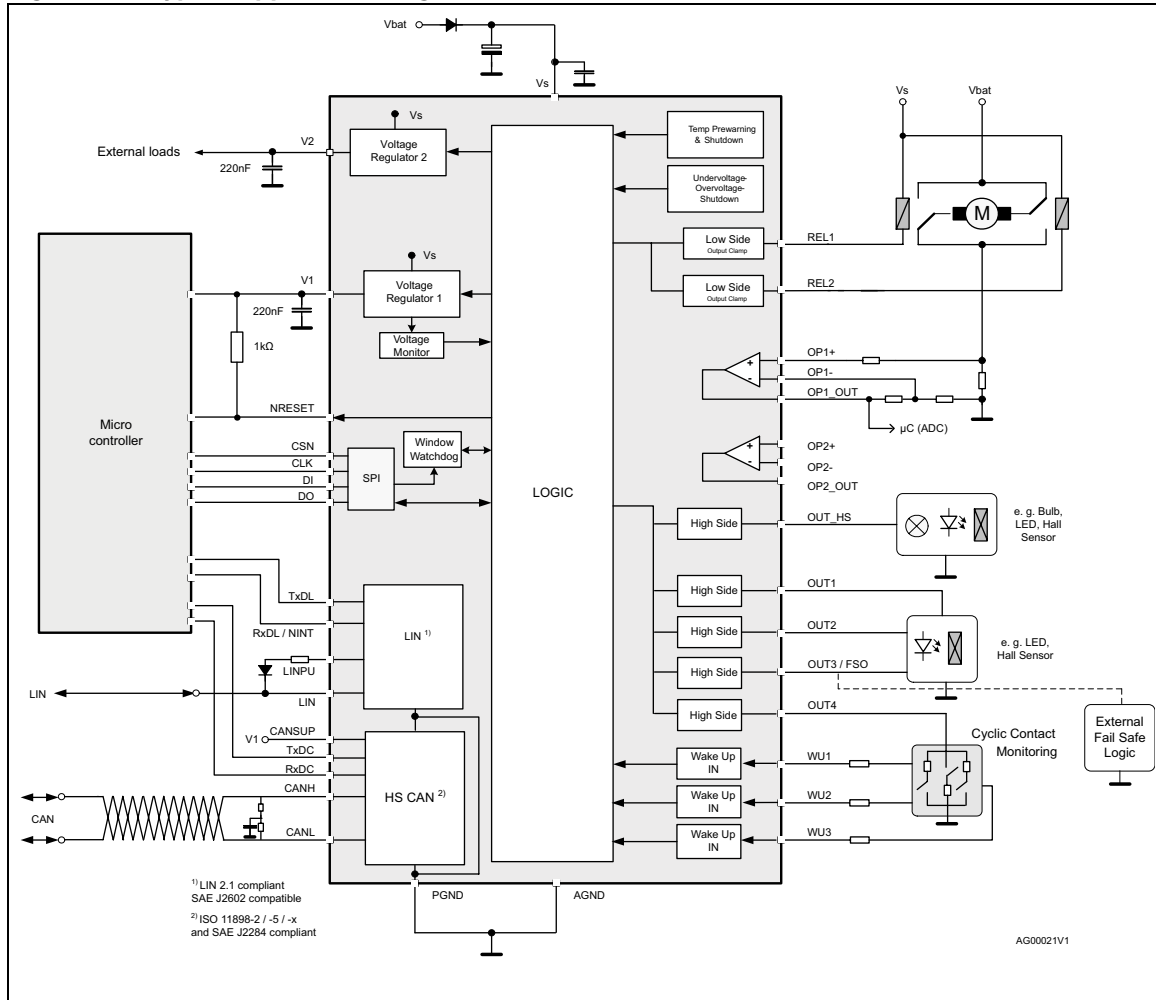

5 Electrical specifications

5.1 Absolute maximum rating

Table 8. Absolute maximum rating

Symbol	Parameter/test condition	Value [DC voltage]	Unit
V_S	DC supply voltage / "jump start"	-0.3 to +28	V
	Single pulse / $t_{max} < 400$ ms "transient load dump"	-0.3 to +40	V
V_1	Stabilized supply voltage, logic supply	-0.3 to $(V_1 + 0.3)$ V $V_1 < V_S$	V
V_2	Stabilized supply voltage	-0.3 to +28	V
V_{DI} , V_{CLK} V_{DO} , V_{RXDL} V_{NRESET} V_{RXDC}	Logic input / output voltage range	-0.3 to $V_1+0.3$	V
V_{TXDC} , V_{TXDL} , V_{CSN}	Multi level inputs	-0.3 to $V_S+0.3$	V
V_{REL1} , V_{REL2} ,	Low-side output voltage range	-0.3 to +40	V
$V_{OUT1..4}$, V_{OUT_HS}	High-side output voltage range	-0.3 to $V_S+0.3$	V
$V_{WU1..3}$	Wake up input voltage range	-0.3 to $V_S+0.3$	V
V_{OP1P} , V_{OP1M} , V_{OP2P} , V_{OP2M} ,	Opamp1 input voltage range Opamp2 input voltage range	-0.3 to $V_1+0.3$	V
V_{OPOUT1} , V_{OPOUT2}	Analog Output voltage range	-0.3 to $V_S+0.3$	V
V_{LIN} , V_{LINPU}	LIN bus I/O voltage range	-20 to +40	V
I_{Input}	Current injection into V_S related input pins	20	mA
I_{out_inj}	Current injection into V_S related outputs	20	mA
V_{CANSUP}	CAN supply	-0.3 to +5.25	V
V_{CANH} , V_{CANL} , V_{SPLIT}	CAN bus I/O voltage range	-27 to +40	V

Note: All maximum ratings are absolute ratings. Leaving the limitation of any of these values may cause an irreversible damage of the integrated circuit!

Loss of ground or ground shift with externally grounded loads: ESD structures are configured for nominal currents only. If external loads are connected to different grounds, the current load must be limited to this nominal current.

5.2 ESD protection

Table 9. ESD protection

Parameter	Value	Unit
All pins ⁽¹⁾	+/-2	kV
All output pins ⁽²⁾	+/-4	kV
LIN	+/-8 ⁽²⁾ +/-10 ⁽³⁾ +/-6 ⁽⁴⁾	kV
CAN_H, CAN_L	+/-8 ⁽²⁾ +/-6 ⁽⁴⁾	kV
All pins ⁽⁵⁾	+/-500	V
Corner pins ⁽⁵⁾	+/-750	V
All pins ⁽⁶⁾	+/-200	V

1. HBM (human body model, 100 pF, 1.5 kΩ) according to MIL 883C, method 3015.7 or EIA/JESD22A114-A.
2. HBM with all none zapped pins grounded.
3. Indirect ESD test according to IEC 61000-4-2 (150 pF, 330 Ω) and 'Hardware Requirements for LIN, CAN and Flexray Interfaces in Automotive Applications' (version 1.1, 2009-12-02).
4. Direct ESD test according to IEC 61000-4-2 (150 pF, 330 Ω) and 'Hardware Requirements for LIN, CAN and Flexray Interfaces in Automotive Applications' (version 1.1, 2009-12-02); $C_{bus,LIN} = 220$ pF.
5. Charged device model.
6. Machine model: $C = 200$ pF; $R = 0$ Ω.

5.3 Thermal data

Table 10. Operating junction temperature

Symbol	Parameter	Value	Unit
T_j	Operating junction temperature	-40 to 150	°C
R_{thjA}	Thermal resistance junction / ambient	See Figure 25	°K/W

Table 11. Temperature warning and thermal shutdown

Symbol	Parameter	Min.	Typ.	Max.	Unit	
$T_{W ON}$	Thermal over temperature warning threshold	$T_j^{(1)}$	120	130	140	°C
$T_{SD1 OFF}$	Thermal shutdown junction temperature 1	$T_j^{(1)}$	130	140	150	°C
$T_{SD2 OFF}$	Thermal shutdown junction temperature 2	$T_j^{(1)}$	150	160	170	°C
$T_{SD2 ON}$		Hysteresis		5		°C
$T_{SD12hys}$						

1. Non-overlapping

Figure 23. Thermal data of PowerSSO-36

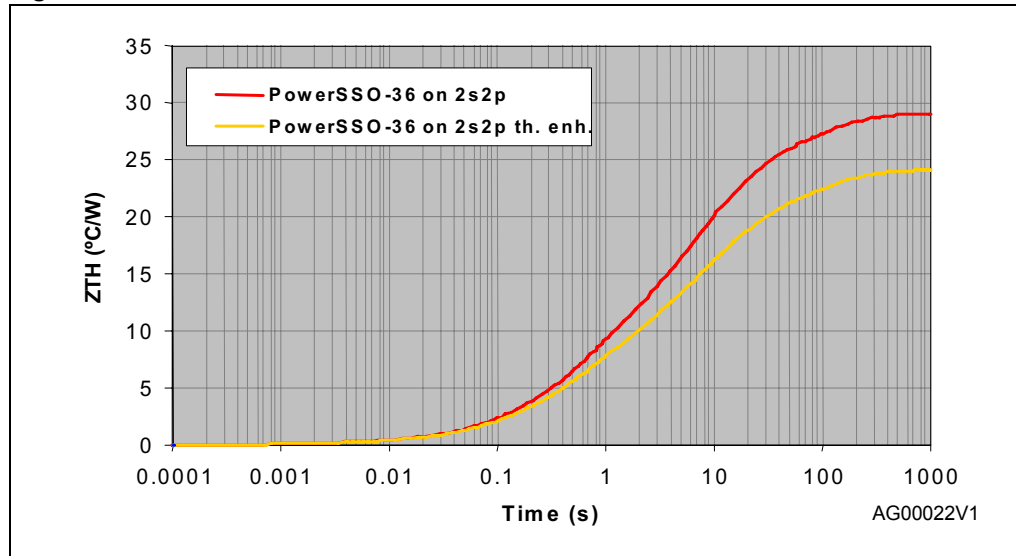

5.4 Package and PCB thermal data

5.4.1 PowerSSO-36 thermal data

Figure 24. PowerSSO-36 PC board

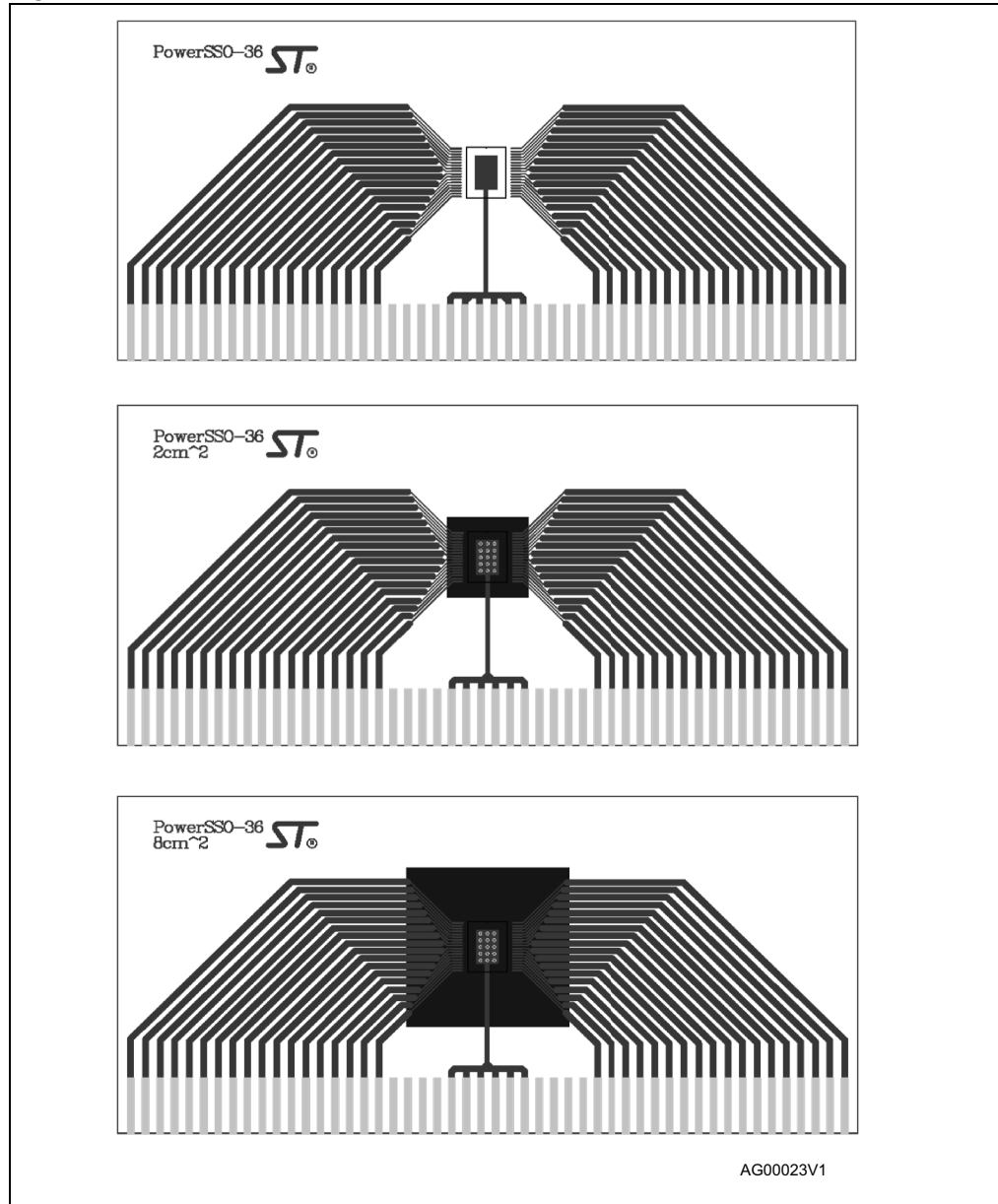

Note: *Layout condition of R_{th} and Z_{th} measurements (board finish thickness 1.6 mm +/- 10% board double layer, board dimension 129x60, board Material FR4, Cu thickness 0.070 mm (front and back side), thermal vias separation 1.2 mm, thermal via diameter 0.3 mm +/- 0.08 mm, Cu thickness on vias 0.025 mm).*

Figure 25. PowerSSO-36 Thermal Resistance junction to ambient vs PCB copper area (V1 ON)

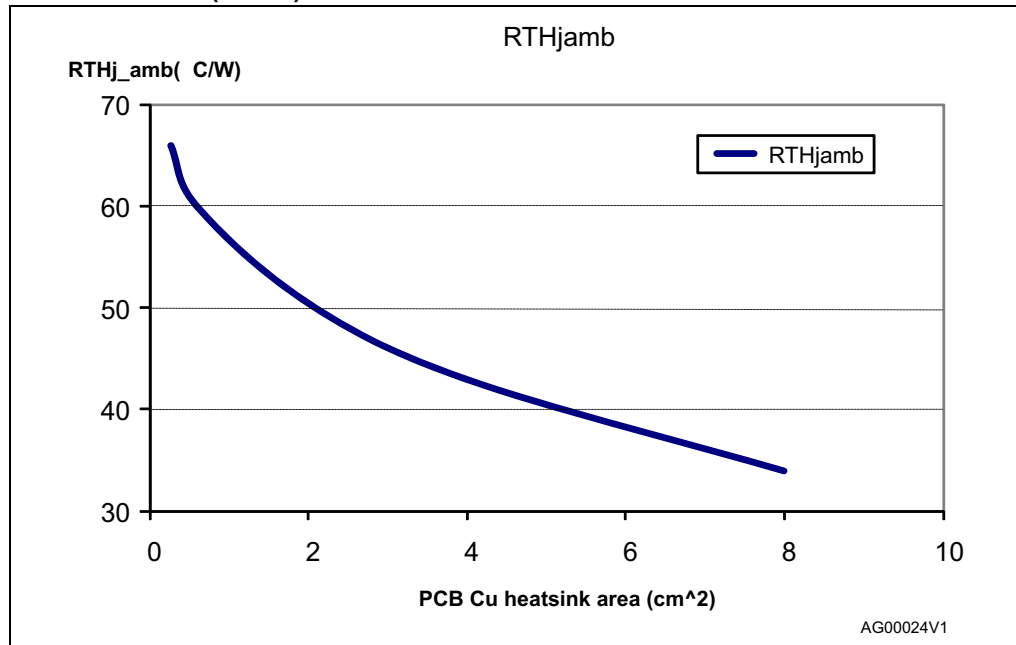

Figure 26. PowerSSO-36 Thermal Impedance junction to ambient vs PCB copper area (single pulse with V1 ON)

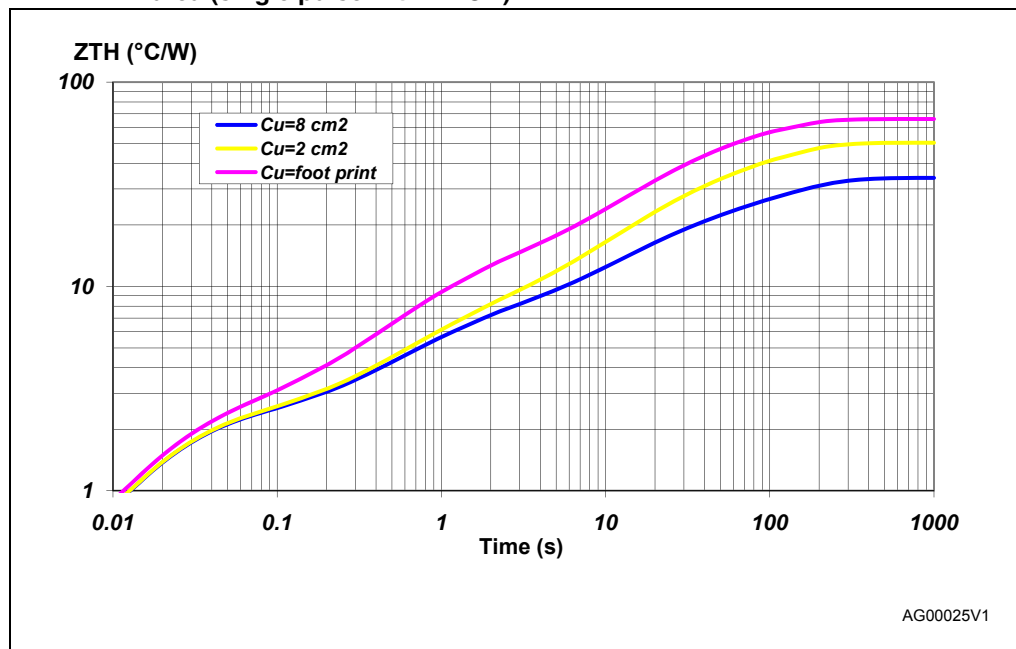
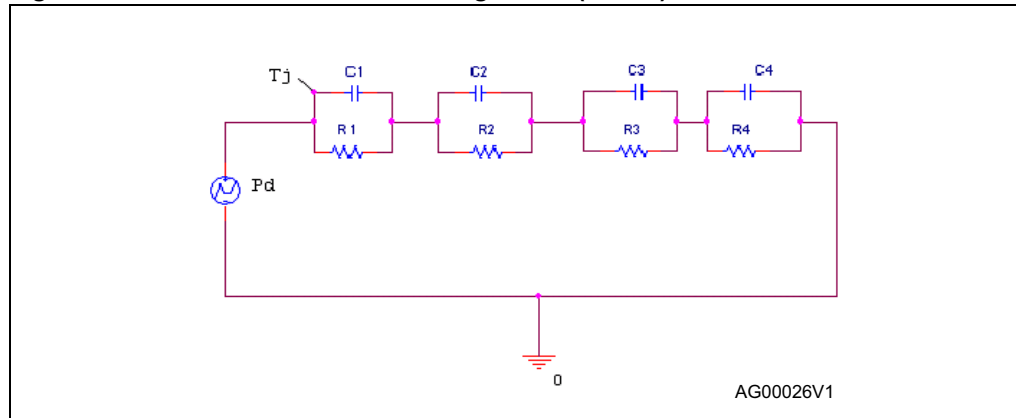

Figure 27. PowerSSO-36 thermal fitting model (V1 ON)



Equation 1: pulse calculation formula

$$Z_{TH\delta} = R_{TH} \cdot \delta + Z_{THtp}(1 - \delta)$$

$$\text{where } \delta = t_p/T$$

Table 12. Thermal parameter

Area/island (cm ²)	Footprint	2	8
R1 (°C/W)	2		
R2 (°C/W)	8	4	4
R3 (°C/W)	20	15.5	10
R4 (°C/W)	36	29	18
C1 (W.s/°C)	0.01		
C2 (W.s/°C)	0.1	0.2	0.2
C3 (W.s/°C)	0.8	1	1.5
C4 (W.s/°C)	2	3	6

5.5 Electrical characteristics

5.5.1 Supply and supply monitoring

The voltages are referred to ground and currents are assumed positive, when the current flows into the pin $T_j = -40\text{ °C}$ to 130 °C , unless otherwise specified.

Table 13. Supply and supply monitoring

Symbol	Parameter	Test condition	Min.	Typ.	Max.	Unit
V_{SUV}	V_S undervoltage threshold	V_S increasing / decreasing	5.11		5.81	V
V_{hyst_UV}	V_S undervoltage hysteresis		0.0	0.1	0.15	V
V_{SOV}	V_S overvoltage threshold	V_S increasing / decreasing	18.5		22	V
V_{hyst_OV}	V_S overvoltage hysteresis	Hysteresis	0.5	1	1.5	V
t_{ovuv_filt}	V_S over/undervoltage filter time			$64 \cdot T_{osc}$		
$I_{V(act)}$	Current consumption in active mode	$V_S = 12V$ TxD CAN = high TxD LIN = high $V_1 = \text{on}, V_2 = \text{on}$ HS/LS driver off		6	12	mA
$I_{V(BAT)}$	Current consumption in V_{BAT} standby mode	$V_S = 12V$ Both voltage regulators deactivated, no wake-up request ⁽¹⁾ HS/LS driver off	8	12	28	μA
$I_{V(BAT)CS}$	Current consumption in V_{BAT} standby mode with cyclic sense enabled	$V_S = 12V$ Both voltage regulators deactivated, $T = 50\text{ ms}, t_{on} = 100\text{ }\mu s$ no wake-up request ⁽¹⁾	70	110	130	μA
$I_{V(BAT)CW}$	Current consumption in V_{BAT} standby mode with cyclic wake enabled	$V_S = 12V$ Both voltage regulators deactivated During standby phase no wake-up request ⁽¹⁾	70	110	130	μA
I_{V1}	Current consumption in V_1 -standby mode	$V_S = 12V$ Voltage Regulator V_1 active, ($I_{V1} < I_{cmp}$) no wake-up request ⁽¹⁾ HS/LS driver off	16	51	76	μA

1. Conditions for no wake-up request are (all conditions must be met):

$$2\text{ V} < \text{LIN} < (V_S - 2\text{ V})$$

$$0.4\text{ V} < (\text{CAN_H} - \text{CAN_L}) < 1.2\text{ V}$$

$$1\text{ V} < V_{WUth} < (V_S - 2\text{ V})$$

The current consumption in standby modes with cyclic sense can be calculated using the following formulas:

$$I_{V(BAT)CS} = I_{V(BAT)} + 55\text{ }\mu A + (2\text{ mA} \cdot (t_{ON} + 100\text{ }\mu s) / T)$$

$$I_{V1}CS = I_{V1} + 55\text{ }\mu A + (2\text{ mA} \cdot (t_{ON} + 100\text{ }\mu s) / T)$$

5.5.2 Oscillator

The voltages are referred to ground and currents are assumed positive, when the current flows into the pin. $4.5\text{ V} \leq V_S \leq 28\text{ V}$; all outputs open; $T_j = -40\text{ }^\circ\text{C}$ to $130\text{ }^\circ\text{C}$, unless otherwise specified.

Table 14. Oscillator

Symbol	Parameter	Test condition	Min.	Typ.	Max.	Unit
F_{CLK}	Oscillation frequency		0.80	1.0	1.35	MHz

5.5.3 Power-on reset (V_S)

All outputs open; $T_j = -40\text{ }^\circ\text{C}$ to $130\text{ }^\circ\text{C}$, unless otherwise specified.

Table 15. Power-on reset (V_S)

Symbol	Parameter	Test condition	Min.	Typ.	Max.	Unit
V_{POR}	V_{POR} threshold	V_S increasing		3.45	4.5	V
V_{POR}	V_{POR} threshold	V_S decreasing ⁽¹⁾	2.65		3.5	V

1. This threshold is valid if V_S had already reached 7V previously

5.5.4 Voltage regulator V_1

The voltages are referred to ground and currents are assumed positive, when the current flows into the pin. $4.5\text{ V} \leq V_S \leq 28\text{ V}$; $T_j = -40\text{ }^\circ\text{C}$ to $130\text{ }^\circ\text{C}$, unless otherwise specified.

Table 16. Voltage regulator V_1

Symbol	Parameter	Test condition	Min.	Typ.	Max.	Unit
V_1	Output voltage			5.0		V
V_1	Output voltage tolerance Active mode	$I_{\text{LOAD1}} = 4\text{ mA}$ to 100 mA ; $V_S = 13.5\text{ V}$	-2		+2	%
V_{hc1}	Output voltage tolerance active mode, high current	$I_{\text{LOAD1}} = 100\text{ mA}$ to 250 mA ; $V_S = 13.5\text{ V}$	-3		+3	%
		$I_{\text{LOAD1}} = 250\text{ mA}$; $V_S = 13.5\text{ V}$	-5		+5	%
V_{STB1}	Output voltage tolerance V_1 -standby mode	$I_{\text{LOAD1}} = 0\text{ }\mu\text{A}$ to 4 mA ; $V_S = 13.5\text{ V}$	-2		+4	%
V_{DP1}	Drop-out voltage	$I_{\text{LOAD1}} = 50\text{ mA}$; $V_S = 5\text{ V}$		0.2	0.4	V
		$I_{\text{LOAD1}} = 100\text{ mA}$; $V_S = 4.5\text{ V}$		0.2	0.5	V
		$I_{\text{LOAD1}} = 100\text{ mA}$; $V_S = 5\text{ V}$		0.3	0.5	V
		$I_{\text{LOAD1}} = 150\text{ mA}$; $V_S = 4.5\text{ V}$		0.45	0.6	V
		$I_{\text{LOAD1}} = 150\text{ mA}$; $V_S = 5.0\text{ V}$		0.45	0.6	V
I_{CC1}	Output current in active mode	Max. continuous load current			250	mA
I_{CCmax1}	Short circuit output current	Current limitation	340	600	900	mA

Table 16. Voltage regulator V₁ (continued)

Symbol	Parameter	Test condition	Min.	Typ.	Max.	Unit
C _{load1}	Load capacitor1	Ceramic (+/- 20%)	0.22 ⁽¹⁾			µF
t _{TSD}	V ₁ deactivation time after thermal shutdown			1		sec
I _{cmp_ris}	Current comp. rising thresh.	Rising current	1.0	2.5	4	mA
I _{cmp_fal}	Current comp. falling threshold	Falling current	0.8	1.95	3.1	mA
I _{cmp_hys}	Current comp. hysteresis			0.5		mA
V _{1fail}	V ₁ fail threshold	V ₁ forced		2		V
tV _{1fail}	V ₁ fail filter time			2		µs
tV _{1short}	V ₁ short filter time			4		ms

1. Nominal capacitor value required for stability of the regulator. Tested with 220 nF ceramic (+/- 20 %). Capacitor must be located close to the regulator output pin.

5.5.5 Voltage regulator V₂

The voltages are referred to ground and currents are assumed positive, when the current flows into the pin. $4.5\text{ V} \leq V_S \leq 28\text{ V}$; $T_j = -40\text{ °C}$ to 130 °C , unless otherwise specified.

Table 17. Voltage regulator V₂

Symbol	Parameter	Test condition	Min.	Typ.	Max.	Unit
V ₂	Output voltage			5,0		V
V ₂	Output voltage tolerance active mode	I _{LOAD2} = 1 mA to 50 mA; V _S = 13.5 V			+/- 3	%
V _{hc1}	Output voltage tolerance active mode	I _{LOAD2} = 50 mA to 80 mA; V _S = 13,5 V			+/- 4	%
V ₂	Output voltage tolerance active mode, high current	I _{LOAD2} = 100 mA; V _S = 13.5 V			+/- 6	%
V _{STB2}	Output voltage tolerance V ₁ standby mode	I _{LOAD2} = 1 mA; V _S = 13.5 V			+/-6.5	%
V _{DP2}	Drop-out voltage	I _{LOAD2} = 25 mA; V _S = 5.25 V		0.3	0.4	V
		I _{LOAD2} = 50 mA; V _S = 5.25 V		0.4	0.7	V
I _{CC2}	Output current in active mode	Max. continuous load current			100	mA
I _{CCmax2}	Short circuit output current	Current limitation	150	280	450	mA
C _{load}	Load capacitor	Ceramic (+/- 20 %)	0.22 ⁽¹⁾			µF
V _{2fail}	V ₂ fail threshold	V ₂ forced			2	V
tV _{2fail}	V ₂ fail filter time			2		µs
tV _{2short}	V ₂ short filter time			4		ms

1. Nominal capacitor value required for stability of the regulator. Tested with 220 nF ceramic (+/- 20 %). Capacitor must be located close to the regulator output pin.

5.5.6 Reset output

The voltages are referred to GND and currents are assumed positive, when the current flows into the pin. $4.0\text{ V} < V_S = 28\text{ V}$; $T_j = -40\text{ }^\circ\text{C}$ to $130\text{ }^\circ\text{C}$, unless otherwise specified.

Table 18. Reset output

Symbol	Parameter	Test condition	Min.	Typ.	Max.	Unit
V_{RT1}	Reset threshold voltage1	V_1 decreasing	3.7	3.9	4.1	V
V_{RT2}	Reset threshold voltage2	V_1 decreasing	4.2	4.3	4.45	V
V_{RT3}	Reset threshold voltage3	V_1 decreasing	4.25	4.4	4.55	V
V_{RT4}	Reset threshold voltage4	V_1 decreasing	4.5	4.60	4.75	V
V_{RT4}	Reset threshold voltage4	V_1 increasing	4.7	4.8	4.9	V
V_{RESET}	Reset pin low output voltage	$V_1 > 1\text{ V}$; $I_{RESET} = 5\text{ mA}$		0,2	0,4	V
R_{RESET}	Reset pull up int. resistor		80	110	150	k Ω
t_{RR}	Reset reaction time	$I_{LOAD1} = 1\text{ mA}$	6		40	μs
t_{UV1}	V_1 under-voltage filter time			16		μs
Trd	Reset pulse duration		1.46	2	2.5	ms

5.5.7 Watchdog

$4.5\text{ V} < V_S < 28\text{ V}$; $4.8\text{ V} < V_1 < 5.2\text{ V}$; $T_j = -40\text{ }^\circ\text{C}$ to $130\text{ }^\circ\text{C}$, unless otherwise specified, see [Figure 28](#) and [Figure 29](#).

Table 19. Watchdog

Symbol	Parameter	Test condition	Min.	Typ.	Max.	Unit
t_{LW}	Long open window		48,75	65	81,25	ms
T_{EFW1}	Early failure window 1				4.5	ms
T_{LFW1}	Late failure window 1		20			ms
T_{SW1}	Safe window 1		7.5		12	ms
T_{EFW2}	Early failure window 2				22.3	ms
T_{LFW2}	Late failure window 2		100			ms
T_{SW2}	Safe window 2		37.5		60	ms
T_{EFW3}	Early failure window 3				45	ms
T_{LFW3}	Late failure window 3		200			ms
T_{SW3}	Safe window 3		75		120	ms
T_{EFW4}	Early failure window 4				90	ms
T_{LFW4}	Late failure window 4		400			ms
T_{SW4}	Safe window 4		150		240	ms

Figure 28. Watchdog timing (long, early, late and safe window)

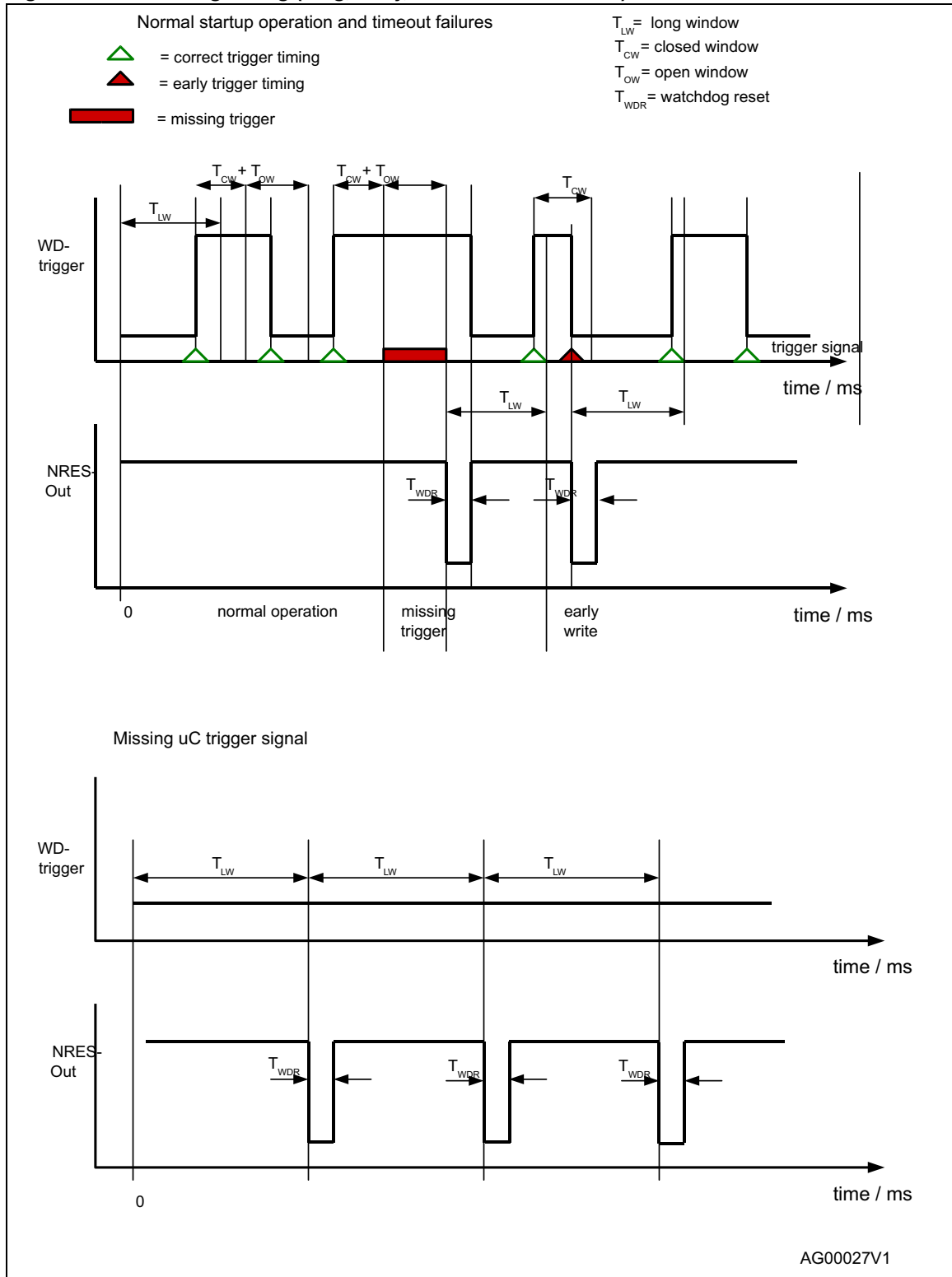
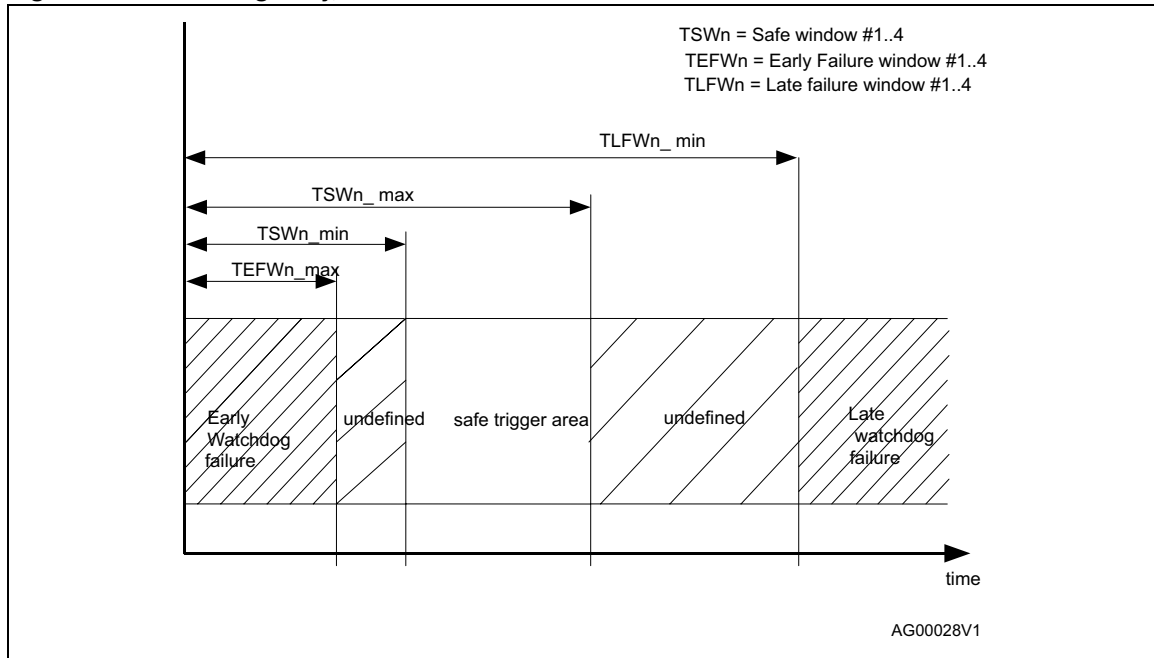

Figure 29. Watchdog early, late and safe windows



5.5.8 High-side outputs

The voltages are referred to GND and currents are assumed positive, when the current flows into the pin. $6\text{ V} \leq V_S \leq 18\text{ V}$; $4.8\text{ V} \leq V_1 \leq 5.2\text{ V}$; $T_j = -40\text{ }^\circ\text{C}$ to $130\text{ }^\circ\text{C}$, unless otherwise specified.

Table 20. Output (OUT_HS)

Symbol	Parameter	Test condition	Min.	Typ.	Max.	Unit
$R_{DS\text{ON}}$	Static drain source on-resistance (IOUT_HS = 150 mA)	$T_j = 25\text{ }^\circ\text{C}$		1	2	Ω
		$T_j = 125\text{ }^\circ\text{C}$		1.6	3	Ω
$t_{d\text{ON}}$	Switch on delay time	$0.2 V_S$	5	35	60	μs
$t_{d\text{OFF}}$	Switch off delay time	$0.8 V_S$	40	95	150	μs
t_{SCF}	Short circuit filter time	Tested by scan chain		$64 \cdot T_{\text{OSC}}$		
$t_{d\text{ARHS}}$	Auto recovery filter time	Tested by scan chain		$400 \cdot T_{\text{OSC}}$		
dV_{OUT}/dt	Slew rate		0,18	0,5	0,8	V/ μs
I_{OUT}	Short circuit shutdown current		480	900	1320	mA
I_{OLD}	Open-load detection current		40	80	120	mA
t_{OLDT}	Open-load detection time	Tested by scan chain		$64 \cdot T_{\text{OSC}}$		
$I_{\text{FW}}^{(1)}$	Loss of GND current (ESD structure)		100			mA

1. Parameter guaranteed by design

The voltages are referred to GND and currents are assumed positive, when the current flows into the pin. $6\text{ V} \leq V_S \leq 18\text{ V}$; $4.8\text{ V} \leq V_1 \leq 5.2\text{ V}$; $T_j = -40\text{ }^\circ\text{C}$ to $130\text{ }^\circ\text{C}$, unless otherwise specified.

Table 21. Outputs (OUT1...4)

Symbol	Parameter	Test Condition	Min.	Typ.	Max.	Unit
$R_{DS(ON)}$	Static drain source on-resistance (IOUT_HS = 150mA)	$I_{LOAD} = 60\text{ mA}$ @ $T_j = +25\text{ }^\circ\text{C}$		7	13	Ω
I_{OUT}	Short circuit shutdown current	$8\text{ V} < V_S < 16\text{ V}$	140	235	350	mA
I_{OLD}	Open-load detection current 1		0.9	2	4.5	mA
dV_{OUT}/dt	Slew rate		0.2	0.5	0.8	V/ μs
$t_{d(ON)}$	Switch ON delay time	$0.2 V_S$	5	35	60	μs
$t_{d(OFF)}$	Switch OFF delay time	$0.8 V_S$	30	95	150	μs
t_{SCF}	Short circuit filter time	Tested by scan chain		$64 \cdot T_{OSC}$		
$I_{FW}^{(1)}$	Loss of GND current (ESD structure)		100			mA
t_{OLDT}	Open-load detection time	Tested by scan chain		$64 \cdot T_{OSC}$		

1. Parameter guaranteed by design

5.5.9 Relay drivers

The voltages are referred to GND and currents are assumed positive, when the current flows into the pin. $6\text{ V} \leq V_S \leq 18\text{ V}$; $4.8\text{ V} \leq V_1 \leq 5.2\text{ V}$; $T_j = -40\text{ }^\circ\text{C}$ to $130\text{ }^\circ\text{C}$, unless otherwise specified.

Table 22. Relay drivers

Symbol	Parameter	Test condition	Min.	Typ.	Max.	Unit
$R_{DS(ON)}$	DC output resistance	$I_{LOAD} = 100\text{ mA}$ @ $T_j = +25\text{ }^\circ\text{C}$		2	3	Ω
I_{OUT}	Short circuit shutdown current	$8\text{ V} < V_S < 16\text{ V}$	250	375	500	mA
V_Z	Output clamp voltage ⁽¹⁾	$I_{LOAD} = 100\text{ mA}$	40		48	V
t_{ONHL}	Turn on delay time to 10% V_{OUT}		5	50	100	μs
t_{OFFLH}	Turn off delay time to 90% V_{OUT}		5	50	100	μs
t_{SCF}	Short circuit filter time	Tested by scan chain		$64 \cdot T_{OSC}$		
dV_{OUT}/dt	Slew Rate		0.2	2	4	V/ μs

1. The output is capable to switch off relay coils with the impedance of $R_L = 160\Omega$; $L = 300\text{mH}$ ($R_L = 220\Omega$; $L = 420\text{mH}$); at $V_S = 40\text{V}$ (load dump condition)

5.5.10 Wake up inputs (WU1... WU3)

The voltages are referred to GND and currents are assumed positive, when the current flows into the pin. $6\text{ V} \leq V_S \leq 18\text{ V}$; $T_j = -40\text{ }^\circ\text{C}$ to $130\text{ }^\circ\text{C}$, unless otherwise specified.

Table 23. Wake up inputs (WU1... WU3)

Symbol	Parameter	Test condition	Min.	Typ.	Max.	Unit
V_{WUthp}	Wake-up negative edge threshold voltage		$0.4 \cdot V_S$	$0.45 \cdot V_S$	$0.5 \cdot V_S$	V
V_{WUthn}	Wake-up positive edge threshold voltage		$0.5 \cdot V_S$	$0.55 \cdot V_S$	$0.6 \cdot V_S$	V
V_{HYST}	Hysteresis		$0.05 \cdot V_S$	$0.1 \cdot V_S$	$0.15 \cdot V_S$	V
t_{WU_stat}	Static wake filter time			$64 \cdot T_{OSC}$		μs
I_{WU_stdby}	Input current in standby mode	$1\text{ V} > V_{in} > (V_S - 2\text{ V})$	9	15	28	μA
R_{WU_act}	Input resistor to Gnd in active mode and in standby mode during wake-up request		80	160	300	$\text{k}\Omega$
t_{WU_cyc}	Cyclic wake filter time		$16^{(1)}$			μs

1. Blanking time 80 μs or 800 μs .

5.5.11 High speed CAN transceiver^(b)

The voltages are referred to GND and currents are assumed positive, when the current flows into the pin.

$6\text{ V} \leq V_S \leq 18\text{ V}$; $4.8\text{ V} \leq V_{cansup} \leq 5.2\text{ V}$; $T_{junction} = -40\text{ }^\circ\text{C}$ to $130\text{ }^\circ\text{C}$, unless otherwise specified.

Table 24. CAN communication operating range

Symbol	Parameter	Test condition	Min.	Typ.	Max.	Unit
V_{SCOM}	Supply voltage operating range for CAN communication	Active mode, $V_1 = V_{CANSUP}$	5.5	-	18	V

Table 25. CAN transmit data input: pin TXDC

Symbol	Parameter	Test condition	Min.	Typ.	Max.	Unit
$V_{TXDCLOW}$	Input voltage dominant level	Active mode, $V_1 = 5\text{ V}$	1.35	1.8		V
$V_{TXDCHIGH}$	Input voltage recessive level	Active mode, $V_1 = 5\text{ V}$		2.7	2.9	V
$V_{TXDCHYS}$	$V_{TXDCHIGH} - V_{TXDCLOW}$	Active mode, $V_1 = 5\text{ V}$	0.7	1		V
R_{TXDCPU}	TXDC pull up resistor	Active mode, $V_1 = 5\text{ V}$	10	20	35	$\text{k}\Omega$

b. ISO 11898-2 and ISO 11898-5 compliant; SAE J2284 compliant.

Table 26. CAN receive data output: pin RXDC

Symbol	Parameter	Test condition	Min.	Typ.	Max.	Unit
$V_{RXDCLOW}$	Output voltage dominant level	Active mode, $V_1 = 5\text{ V}$, 2 mA		0.2	0.5	V
$V_{RXDCHIGH}$	Output voltage recessive level	Active mode, $V_1 = 5\text{ V}$, 2 mA	4.5			V

Table 27. CAN bus common mode stabilization output termination: pin SPLIT

Symbol	Parameter	Test Condition	Min.	Typ.	Max.	Unit
$V_{SPLIT,I}$	Split output voltage, loaded condition (normal mode)	Active mode; $V_{TXDC} = V_{TXDCHIGH}$; $ I_{split} = 500\ \mu\text{A}$	0.3* V_{CANSUP}	0.5* V_{CANSUP}	0.7* V_{CANSUP}	V
$V_{SPLIT,u}$	Split output voltage, unloaded condition (normal mode)	Active mode; $V_{TXDC} = V_{TXDCHIGH}$; No Load		0.5* V_{CANSUP}	0.55* V_{CANSUP}	V
I_{SPLIT}	Split leakage current (low power mode)	V_1 -standby mode; $-12\text{ V} < V_{SPLIT} < 12\text{ V}$			5	μA

Table 28. CAN transmitter and receiver: pins CANH and CANL

Symbol	Parameter	Test Condition	Min.	Typ.	Max.	Unit
$V_{CANHdom}$	CANH voltage level in dominant state	Active mode; $V_{TXDC} = V_{TXDCLow}$; $R_L = 60\ \Omega$; $R_L = 50\ \Omega$	2.75		4.5	V
$V_{CANLdom}$	CANL voltage level in dominant state	Active mode; $V_{TXDC} = V_{TXDCLow}$; $R_L = 60\ \Omega$; $R_L = 50\ \Omega$	0.5		2.25	V
$V_{DIFF,domOUT}$	Differential output voltage in dominant state: $V_{CANHdom} - V_{CANLdom}$	Active mode; $V_{TXDC} = V_{TXDCLow}$; $R_L = 60\ \Omega$; $R_L = 50\ \Omega$	1.5		3	V
V_{CM}	Driver symmetry: $V_{CANHdom} + 0V_{CANLdom}$	Active mode; $V_{TXDC} = V_{TXDCLow}$; $R_L = 60\ \Omega$; $C_{SPLIT} = 4.7\ \text{pF}$	0.9* V_{CANSUP}	V_{CANSUP}	1.1* V_{CANSUP}	V
$V_{CANHrec}$	CANH voltage level in recessive state (normal mode)	Active mode; $V_{TXDC} = V_{TXDCHIGH}$; no load	2	2.5	3	V
$V_{CANLrec}$	CANL voltage level in recessive state (normal mode)	Active mode; $V_{TXDC} = V_{TXDCHIGH}$; no load	2	2.5	3	V
$V_{CANHrecLP}$	CANH voltage level in recessive state (low power mode)	V_1 standby mode; $V_{TXDC} = V_{TXDCHIGH}$; no load	-0.1	0	0.1	V
$V_{CANLrecLP}$	CANL voltage level in recessive state (low power mode)	V_1 standby mode; $V_{TXDC} = V_{TXDCHIGH}$; no load	-0.1	0	0.1	V

Table 28. CAN transmitter and receiver: pins CANH and CANL (continued)

Symbol	Parameter	Test Condition	Min.	Typ.	Max.	Unit
$V_{DIFF,recOUT}$	Differential output voltage in recessive state (normal mode): $V_{CANHrec} - V_{CANLrec}$	Active mode; $V_{TXDC} = V_{TXDCHIGH}$; no load	-50		50	mV
$V_{DIFF,recOUTLP}$	Differential output voltage in recessive state (low power mode): $V_{CANHrec} - V_{CANLrec}$	V_1 standby mode; $V_{TXDC} = V_{TXDCHIGH}$; no load	-50		50	mV
$V_{CANHL,CM}$	Common mode Bus voltage	Measured with respect to the ground of each CAN node	-12		12	V
$I_{OCANH,dom}$	CANH output current in dominant state	Active mode; $V_{TXDC} = V_{TXDCLow}$; $V_{CANH} = 0$ V	-160	-75	-45	mA
$I_{OCANL,dom}$	CANL output current in dominant state	Active mode; $V_{TXDC} = V_{TXDCLow}$; $V_{CANL} = 5$ V	45	75	160	mA
$I_{Leakage}$	Input leakage current	Unpowered device; $V_{BUS} = 5$ V	0		250	μ A
R_{in}	Internal resistance	Active mode & V_1 standby mode; $V_{TXDC} = V_{TXDCHIGH}$; no load	20	27.5	38	k Ω
$R_{in,matching}$	Internal resistor matching CANH, CANL	Active mode & V_1 standby mode; $V_{TXDC} = V_{TXDCHIGH}$; no load $R_{in}(CANH) - R_{in}(CANL)$			3	%
$R_{in,diff}$	Differential internal resistance	Active mode & V_1 standby mode; $V_{TXDC} = V_{TXDCHIGH}$; no load	50	60	75	k Ω
C_{in}	Internal capacitance	Guaranteed by design		20		pF
$C_{in,diff}$	Differential internal capacitance	Guaranteed by design		10		pF
V_{THdom}	Differential receiver threshold voltage recessive to dominant state (normal mode)	Active mode			0.9	V
$V_{THdomLP}$	Differential receiver threshold voltage recessive to dominant state (low power mode)	V_1 standby mode			1.15	V
V_{THrec}	Differential receiver threshold voltage dominant to recessive state (normal mode)	Active mode	0.5			V
$V_{THrecLP}$	Differential receiver threshold voltage dominant to recessive state (low power mode)	V_1 standby mode	0.4			V

Table 29. CAN transceiver timing

Symbol	Parameter	Test condition	Min.	Typ.	Max.	Unit
tTXpd,hl	Propagation delay TXDC to RXDC (high to low)	Active mode; 50 % V _{TXDC} to 50 % V _{RXDC} ; C _{RXDC} = 100 pF; R _L = 60 Ω	0		255	ns
tTXpd,lh	Propagation delay TXDC to RXDC (low to high)	Active mode; 50 % V _{TXDC} to 50 % V _{RXDC} ; C _{RXDC} = 100 pF; R _L = 60 Ω	0		255	ns
t _{wake}	Wake up filter time		0.5		5	μs
t _{dom(TXDC)}	TXDC dominant time-out			700		μs
t _{CAN}	CAN permanent dominant time-out			700		μs

5.5.12 LIN transceiver^(c)

The voltages are referred to GND and currents are assumed positive, when the current flows into the pin.

$6\text{ V} \leq V_S \leq 18\text{ V}$; $4.8\text{ V} \leq V_1 \leq 5.2\text{ V}$; $T_{\text{junction}} = -40\text{ }^\circ\text{C}$ to $130\text{ }^\circ\text{C}$ unless otherwise specified.

Table 30. LIN transmit data input: pin TXD

Symbol	Parameter	Test condition	Min.	Typ.	Max.	Unit
V _{TXDLOW}	Input voltage dominant level	Active mode; V ₁ = 5 V	1,35	1.8		V
V _{TXDHIGH}	Input voltage recessive level	Active mode; V ₁ = 5 V		2.7	2.9	V
V _{TXDHYS}	V _{TXDHIGH} - V _{TXDLOW}	Active mode; V ₁ = 5 V	0.7	1		V
R _{TXDPU}	TXD pull up resistor	Active mode; V ₁ = 5 V	10	20	35	kΩ

Table 31. LIN receive data output: pin RXD

Symbol	Parameter	Test condition	Min.	Typ.	Max.	Unit
V _{RXDLOW}	Output voltage dominant level	Active mode; V ₁ = 5 V, I _{LOAD1} = 2 mA		0.2	0.5	V
V _{RXDHIGH}	Output voltage recessive level	Active mode; V ₁ = 5 V, I _{LOAD1} = 2 mA	4.5			V

Table 32. LIN transmitter and receiver: pin LIN

Symbol	Parameter	Test condition	Min.	Typ.	Max.	Unit
V _{THdom}	Receiver threshold voltage recessive to dominant state		0.4*V _S	0.45*V _S	0.5*V _S	V
V _{Busdom}	Receiver dominant state				0.4*V _S	V

c. LIN 2.1 compliant for Baud rates up to 20 kBit/s
SAE J2602 compatible

Table 32. LIN transmitter and receiver: pin LIN (continued)

Symbol	Parameter	Test condition	Min.	Typ.	Max.	Unit
V_{THrec}	Receiver threshold voltage dominant to recessive state		$0.5 \cdot V_S$	$0.55 \cdot V_S$	$0.6 \cdot V_S$	V
V_{Busrec}	Receiver recessive state		$0.6 \cdot V_S$			V
V_{THhys}	Receiver threshold hysteresis: $V_{THrec} - V_{THdom}$		$0.07 \cdot V_S$	$0.1 \cdot V_S$	$0.175 \cdot V_S$	V
V_{THcnt}	Receiver tolerance center value: $(V_{THrec} + V_{THdom})/2$		$0.475 \cdot V_S$	$0.5 \cdot V_S$	$0.525 \cdot V_S$	V
V_{THwkup}	Receiver wakeup threshold voltage		1.0	1.5	2	V
$V_{THwkdown}$	Receiver wakeup threshold voltage		$V_S - 3.5$	$V_S - 2.5$	$V_S - 1.5$	V
t_{inbus}	Dominant time for wakeup via bus	Sleep mode; edge: rec-dom		$64 \cdot T_{OSC}$		μs
$I_{LINDomSC}$	Transmitter input current limit in dominant state	$V_{TXD} = V_{TXDLOW}$; $V_{LIN} = V_{BATMAX} = 18 V$	40	100	180	mA
$I_{bus_PAS_dom}$	Input leakage current at the receiver incl. pull-up resistor	$V_{TXD} = V_{TXDHIGH}$; $V_{LIN} = 0 V$; $V_{BAT} = 12 V^{(1)}$	-1			mA
$I_{bus_PAS_rec}$	Transmitter input current in recessive state	$V_{TXD} = V_{TXDHIGH}$; $8 V < V_{LIN}$; $V_{BAT} < 18 V$; $V_{LIN} \geq V_{BAT}$ in standby modes			20	μA
$I_{bus_NO_GND}$	Input current if loss of GND at device	$GND = V_S$; $0 V < V_{LIN} < 18 V$; $V_{BAT} = 12 V$	-1		1	mA
I_{bus}	Input current if loss of V_{BAT} at device	$GND = V_S$; $0 V < V_{LIN} < 18 V$			100	μA
V_{LINdom}	LIN voltage level in dominant state	Active mode; $V_{TXD} = V_{TXDLOW}$; $I_{LIN} = 40 mA$			1.2	V
V_{LINrec}	LIN voltage level in recessive state	Active mode; $V_{TXD} = V_{TXDHIGH}$; $I_{LIN} = 10 \mu A$	$0.8 \cdot V_S$		1	V
R_{LINup}	LIN output pull up resistor	$V_{LIN} = 0 V$	20	40	60	k Ω

1. Slave mode.

Table 33. LIN transceiver timing

Symbol	Parameter	Test condition	Min.	Typ.	Max.	Unit
t_{RXpd}	Receiver propagation delay time	$t_{RXpd} = \max(t_{RXpdr}, t_{RXpdf});$ $t_{RXpdf} = t(0.5 V_{RXD}) - t(0.45 V_{LIN});$ $t_{RXpdr} = t(0.5 V_{RXD}) - t(0.55 V_{LIN});$ $V_S = 12 V; C_{RXD} = 20 pF;$ $R_{bus'} = 1 k\Omega, C_{bus} = 1 nF;$ $R_{bus} = 660 \Omega, C_{bus} = 6.8 nF;$ $R_{bus} = 500 \Omega, C_{bus} = 10 nF$			6	μs
t_{RXpd_sym}	Symmetry of receiver propagation delay time (rising vs. falling edge)	$t_{RXpd_sym} = t_{RXpdr} - t_{RXpdf};$ $V_S = 12 V;$ $R_{bus} = 1 k\Omega, C_{bus} = 1 nF$	-2		2	μs
D1	Duty cycle 1	$TH_{Rec}(\max) = 0.744 * V_S;$ $TH_{Dom}(\max) = 0.581 * V_S;$ $V_S = 7 V \text{ to } 18 V, t_{bit} = 50 \mu s;$ $D1 = t_{bus_rec}(\min) / (2 * t_{bit});$ $R_{bus} = 1 k\Omega, C_{bus} = 1 nF;$ $R_{bus} = 660 \Omega, C_{bus} = 6.8 nF;$ $R_{bus} = 500 \Omega, C_{bus} = 10 nF$	0.396			
D2	Duty cycle 2	$TH_{Rec}(\min) = 0.284 * V_S;$ $TH_{Dom}(\min) = 0.422 * V_S;$ $V_S = 7.6 \text{ to } 18 V, t_{bit} = 50 \mu s;$ $D2 = t_{bus_rec}(\max) / (2 * t_{bit});$ $R_{bus} = 1 k\Omega, C_{bus} = 1 nF;$ $R_{bus} = 660 \Omega, C_{bus} = 6.8 nF;$ $R_{bus} = 500 \Omega, C_{bus} = 10 nF$			0.581	
D3	Duty cycle 3	$TH_{Rec}(\max) = 0.778 * V_S;$ $TH_{Dom}(\max) = 0.616 * V_S;$ $V_S = 7 V \text{ to } 18 V, t_{bit} = 96 \mu s;$ $D3 = t_{bus_rec}(\min) / (2 * t_{bit});$ $R_{bus} = 1 k\Omega, C_{bus} = 1 nF;$ $R_{bus} = 660 \Omega, C_{bus} = 6.8 nF;$ $R_{bus} = 500 \Omega, C_{bus} = 10 nF$	0.417			
D4	Duty cycle 4	$TH_{Rec}(\min) = 0.251 * V_S;$ $TH_{Dom}(\min) = 0.389 * V_S;$ $V_S = 7.6 V \text{ to } 18 V, t_{bit} = 96 \mu s;$ $D4 = t_{bus_rec}(\max) / (2 * t_{bit});$ $R_{bus} = 1 k\Omega, C_{bus} = 1 nF;$ $R_{bus} = 660 \Omega, C_{bus} = 6.8 nF;$ $R_{bus} = 500 \Omega, C_{bus} = 10 nF$			0.590	
$t_{dom}(TXDL)$	TXDL dominant time-out			12		ms
t_{LIN}	LIN permanent recessive time-out			40		μs
$t_{dom}(BUS)$	LIN bus permanent dominant time-out			12		ms

Table 34. LIN pull-up: pin LINPU

Symbol	Parameter	Test condition	Min.	Typ.	Max.	Unit
$R_{DS\text{ON}}$	ON resistance			10.5	16	Ω
I_{leak}	Leakage current				1	μA

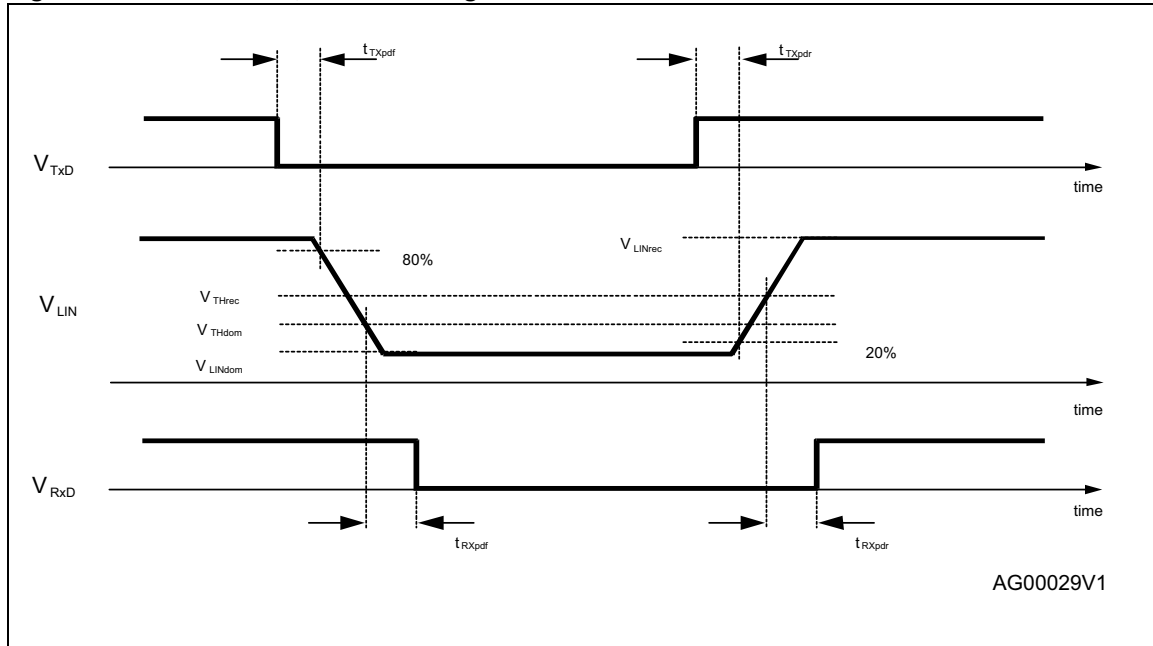
Figure 30. LIN transmit, receive timing

5.5.13 Operational amplifier

The voltages are referred to GND and currents are assumed positive, when the current flows into the pin. $6\text{ V} \leq V_{\text{S}} \leq 18\text{ V}$; $T_{\text{j}} = -40\text{ }^{\circ}\text{C}$ to $130\text{ }^{\circ}\text{C}$, unless otherwise specified.

Table 35. Operational amplifier

Symbol	Parameter	Test condition	Min.	Typ.	Max.	Unit
GBW	GBW product		1	3.5	7.0	MHz
$AVOL_{\text{DC}}$	DC open loop gain		80			dB
PSRR	Power supply rejection	DC, $V_{\text{in}} = 150\text{ mV}$	80			dB
V_{off}	Input offset voltage		-5		+5	mV
V_{ICR}	Common mode input range		-0.2	0	3	V
V_{OH}	Output voltage range high	$I_{\text{LOAD}} = 1\text{ mA}$ to Gnd	$V_{\text{S}} - 0.2$		V_{S}	V
V_{OL}	Output voltage range low	$I_{\text{LOAD}} = 1\text{ mA}$ to V_{S}	0		0.2	V
$I_{\text{Lim+}}$	Output current limitation +	DC	10	15	30	mA
$I_{\text{lim-}}$	Output current limitation -	DC	-10	15	-30	mA

Table 35. Operational amplifier (continued)

Symbol	Parameter	Test condition	Min.	Typ.	Max.	Unit
SR+	Slew rate positive		1	4	10	V/ μ s
SR-	Slew rate negative		-1	-4	-10	V/ μ s

Note: The operational amplifier is on-chip stabilized for external capacitive loads $C_L \leq 25$ pF (all operating conditions)

5.5.14 SPI

Input: CSN

The voltages are referred to ground and currents are assumed positive, when the current flows into the pin. $6\text{ V} \leq V_S \leq 18\text{ V}$; $4.5\text{ V} \leq V_1 \leq 5.3\text{ V}$; all outputs open; $T_j = -40\text{ }^\circ\text{C}$ to $130\text{ }^\circ\text{C}$, unless otherwise specified.

Input: CSN

Table 36. Input: CSN

Symbol	Parameter	Test condition	Min.	Typ.	Max.	Unit
VCSNLOW	Input voltage low level	Normal mode, $V_1 = 5\text{ V}$	1.35	1.8		V
VCSNHIGH	Input voltage high level	Normal mode, $V_1 = 5\text{ V}$		2.7	2.9	V
VCSNHYS	VCSNHIGH - VCSNLOW	Normal mode, $V_1 = 5\text{ V}$	0.6	1.0	1.5	V
ICSNPU	CSN pull up resistor	Normal mode, $V_1 = 5\text{ V}$	10	20	35	k Ω

CLK, DI

The voltages are referred to ground and currents are assumed positive, when the current flows into the pin. $6\text{ V} \leq V_S \leq 18\text{ V}$; $4.5\text{ V} \leq V_1 \leq 5.3\text{ V}$; all outputs open; $T_j = -40\text{ }^\circ\text{C}$ to $130\text{ }^\circ\text{C}$, unless otherwise specified.

Table 37. Input CLK, DI

Symbol	Parameter	Test condition	Min.	Typ.	Max.	Unit
t_{set}	delay time from standby to active mode	Switching from standby to active mode. Time until output drivers are enabled after CSN going to high.		160	300	μ s
$V_{\text{in L}}$	input low level	$V_1 = 5\text{ V}$	1.0	2.05	2.5	V
$V_{\text{in H}}$	input high level	$V_1 = 5\text{ V}$	1.5	2.8	3.5	V
$V_{\text{in Hyst}}$	input hysteresis	$V_1 = 5\text{ V}$	0.4	0.75	1.5	V
I_{in}	pull down current at input	$V_{\text{in}} = 1.5\text{ V}$	5	30	60	μ A

Table 37. Input CLK, DI (continued)

Symbol	Parameter	Test condition	Min.	Typ.	Max.	Unit
$C_{in}^{(1)}$	input capacitance at input CSN, CLK, DI and $PWM_{1,2}$	$0 V < V_1 < 5.3 V$		10	15	pF
f_{CLK}	SPI input frequency at CLK				1	MHz

1. Value of input capacity is not measured in production test. Parameter guaranteed by design.

DI timing

The voltages are referred to ground and currents are assumed positive, when the current flows into the pin. $6 V \leq V_S \leq 18 V$; $4.5 V \leq V_1 \leq 5.3 V$; all outputs open; $T_j = -40\text{ }^\circ\text{C}$ to $130\text{ }^\circ\text{C}$, unless otherwise specified.

Table 38. DI timing⁽¹⁾

Symbol	Parameter	Test condition	Min.	Typ.	Max.	Unit
t_{CLK}	Clock period	$V_1 = 5 V$	1000	-		ns
t_{CLKH}	Clock high time	$V_1 = 5 V$	400	-		ns
t_{CLKL}	Clock low time	$V_1 = 5 V$	400	-		ns
$t_{set\ CSN}$	CSN setup time, CSN low before rising edge of CLK	$V_1 = 5 V$	400	-		ns
$t_{set\ CLK}$	CLK setup time, CLK high before rising edge of CSN	$V_1 = 5 V$	400	-		ns
$t_{set\ DI}$	DI setup time	$V_1 = 5 V$	200	-		ns
$t_{hold\ DI}$	DI hold time	$V_1 = 5 V$	200	-		ns
$t_{r\ in}$	Rise time of input signal DI, CLK, CSN	$V_1 = 5 V$		-	100	ns
$t_{f\ in}$	Fall time of input signal DI, CLK, CSN	$V_1 = 5 V$		-	100	ns

1. See [Figure 32](#).

DO

The voltages are referred to ground and currents are assumed positive, when the current flows into the pin. $6 V \leq V_S \leq 18 V$; $4.5 V \leq V_1 \leq 5.3 V$; all outputs open; $T_j = -40\text{ }^\circ\text{C}$ to $130\text{ }^\circ\text{C}$, unless otherwise specified.

Table 39. DO output pin

Symbol	Parameter	Test condition	Min.	Typ.	Max.	Unit
V_{DOL}	Output low level	$V_1 = 5 V, I_D = -4\text{ mA}$			0.5	V
V_{DOH}	output high level	$V = 5 V, I_D = 4\text{ mA}$	4.5			V

Table 39. DO output pin (continued)

Symbol	Parameter	Test condition	Min.	Typ.	Max.	Unit
I_{DOLK}	3-state leakage current	$V_{CSN} = V_1, 0 V < V_{DO} < V_1$	-10		10	μA
C_{DO}^2	3-state input capacitance	$V_{CSN} = V_1,$ $0 V < V_1 < 5.3 V$		10	15	pF

DO timing

The voltages are referred to ground and currents are assumed positive, when the current flows into the pin. $6 V \leq V_S \leq 18 V$; $4.5 V \leq V_1 \leq 5.3 V$; all outputs open; $T_j = -40\text{ }^\circ\text{C}$ to $130\text{ }^\circ\text{C}$, unless otherwise specified.

Table 40. DO timing⁽¹⁾

Symbol	Parameter	Test condition	Min.	Typ.	Max.	Unit
t_{rDO}	DO rise time	$C_L = 100\text{ pF}, I_{LOAD} = -1\text{ mA}$	-	50	100	ns
t_{fDO}	DO fall time	$C_L = 100\text{ pF}, I_{LOAD} = 1\text{ mA}$	-	50	100	ns
$t_{enDO\ tri\ L}$	DO enable time from 3-state to low level	$C_L = 100\text{ pF}, I_{LOAD} = 1\text{ mA}$ pull-up load to V_1	-	50	250	ns
$t_{disDO\ L\ tri}$	DO disable time from low level to 3-state	$C_L = 100\text{ pF}, I_{LOAD} = 4\text{ mA}$ pull-up load to V_1	-	50	250	ns
$t_{enDO\ tri\ H}$	DO enable time from 3-state to high level	$C_L = 100\text{ pF}, I_{LOAD} = -1\text{ mA}$ pull-down load to GND	-	50	250	ns
$t_{disDO\ H\ tri}$	DO disable time from high level to 3-state	$C_L = 100\text{ pF}, I_{LOAD} = -4\text{ mA}$ pull-down load to GND	-	50	250	ns
t_{dDO}	DO delay time	$V_{DO} < 0.3 V_1,$ $V_{DO} > 0.7 V_1,$ $C_L = 100\text{ pF}$	-	50	250	ns

1. See [Figure 33](#) and [Figure 34](#).

CSN timing

The voltages are referred to ground and currents are assumed positive, when the current flows into the pin. $6 V \leq V_S \leq 18 V$; $4.5 V \leq V_1 \leq 5.3 V$; all outputs open; $T_j = -40\text{ }^\circ\text{C}$ to $130\text{ }^\circ\text{C}$, unless otherwise specified.

Table 41. CSN timing⁽¹⁾

Symbol	Parameter	Test Condition	Min.	Typ.	Max.	Unit
$t_{CSN_HI,min}$	Minimum CSN HI time, active mode	Transfer of SPI-command to Input register	6			μs
$t_{CSNfail}$	CSN low timeout	Tested by scan chain	20	35	50	ms

1. See [Figure 35](#).

RXDL/NINT timing

The voltages are referred to ground and currents are assumed positive, when the current flows into the pin.

$6V \leq V_S \leq 18V$; $4.5V \leq V_1 \leq 5.3V$; all outputs open; $T_j = -40^\circ C$ to $130^\circ C$, unless otherwise specified.

Table 42. RXDL/NINT timing

Symbol	Parameter	Test condition	Min.	Typ.	Max.	Unit
$t_{Interrupt}$	Interrupt pulse duration	Walk-up from $V_{1-standby}$	—	56	—	μs

5.5.15 Inputs TxD_C and TxD_L for Flash mode

$6V \leq V_S \leq 18V$; $4.5V \leq V_1 \leq 5.3V$; $T_j = -40^\circ C$ to $130^\circ C$, voltages are referred to PGND, all outputs open

Table 43. Inputs TxD_C and TxD_L for Flash mode

Symbol	Parameter	Test condition	Min.	Typ.	Max.	Unit
V_{FlashL}	Input low level ($V_{TXDC/L}$ for transition into Flash mode)	$V_1 = 5V$	6.1	7.25	8.4	V
V_{FlashH}	Input high level ($V_{TXDC/L}$ for exit from Flash mode)	$V_1 = 5V$	7.4	8.4	9.4	V
$V_{FlashHYS}$	Input Voltage Hysteresis	$V_1 = 5V$	0.6	0.8	1.0	V

Figure 31. SPI – transfer timing diagram

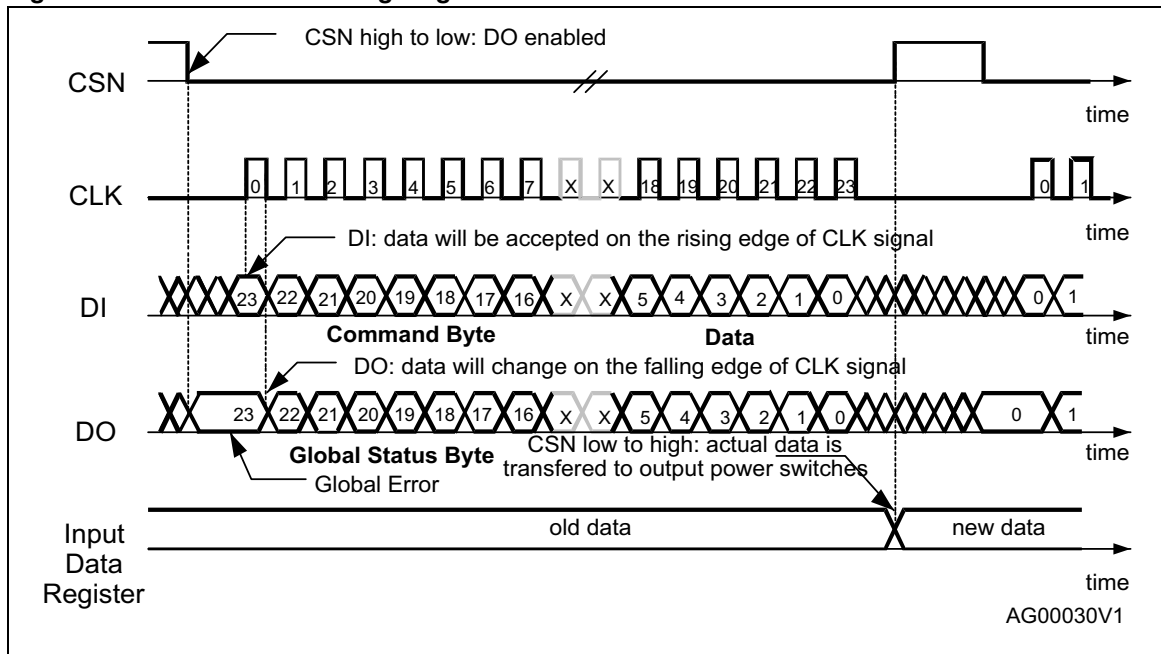

The SPI can be driven by a micro controller with its SPI peripheral running in following mode:

CPOL = 0 and CPHA = 0.

For this mode input data is sampled by the low to high transition of the clock CLK, and output data is changed from the high to low transition of CLK.

Figure 32. SPI - input timing

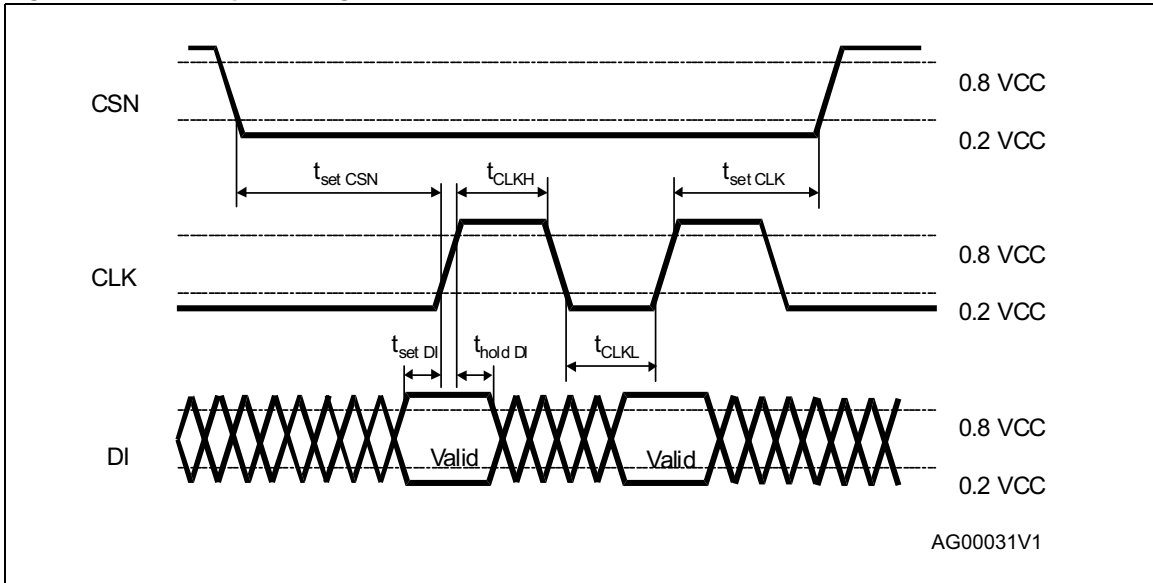

Figure 33. SPI output timing (part 1)

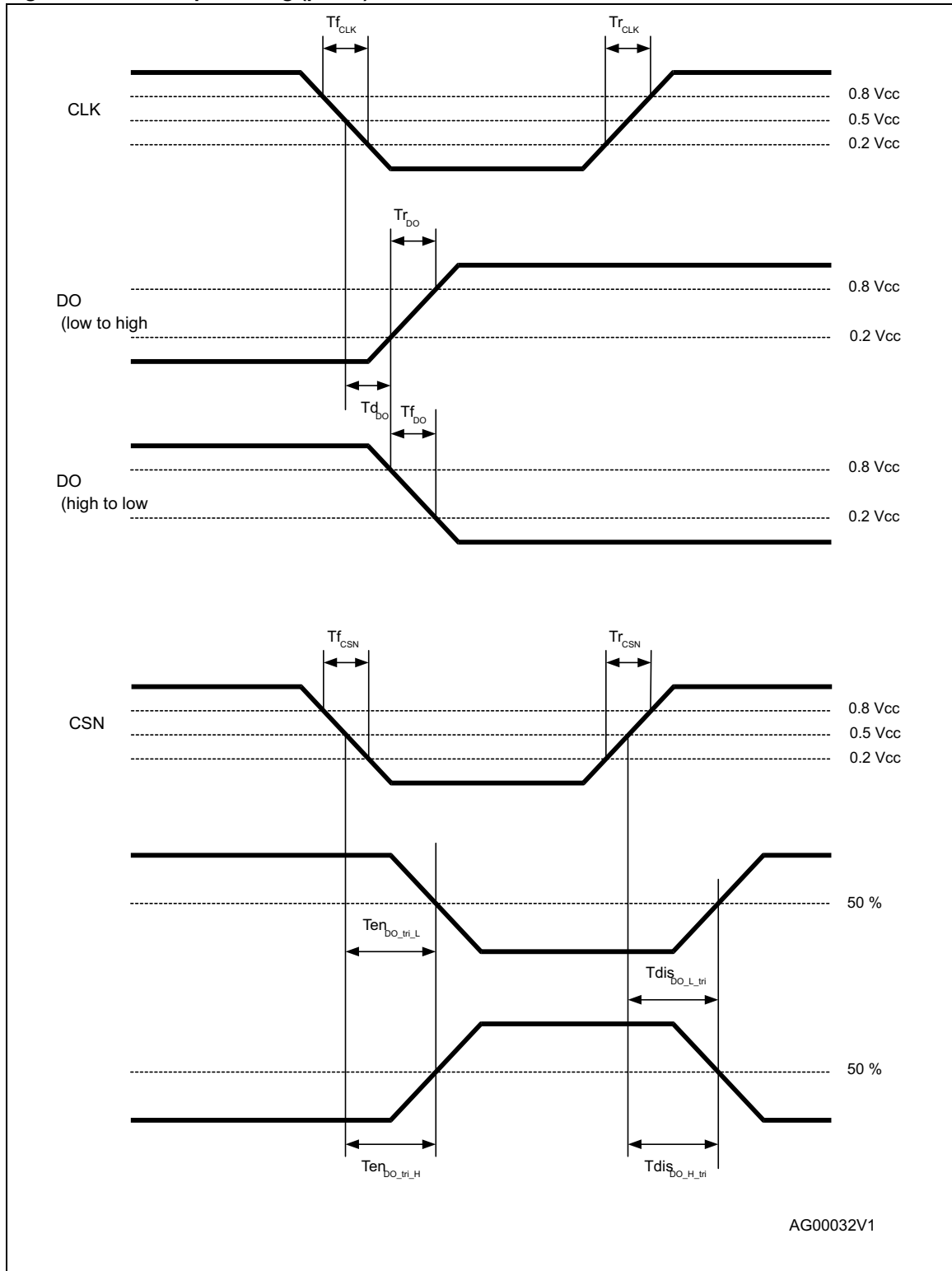

Figure 34. SPI output timing (part 2)

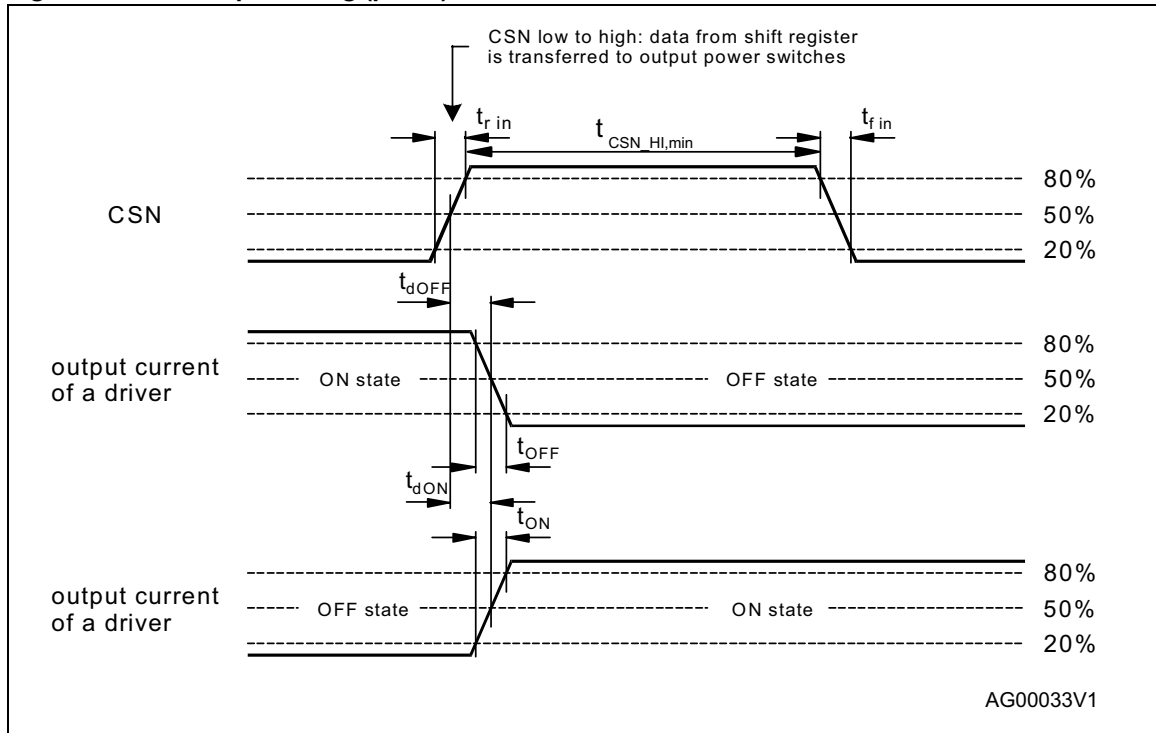
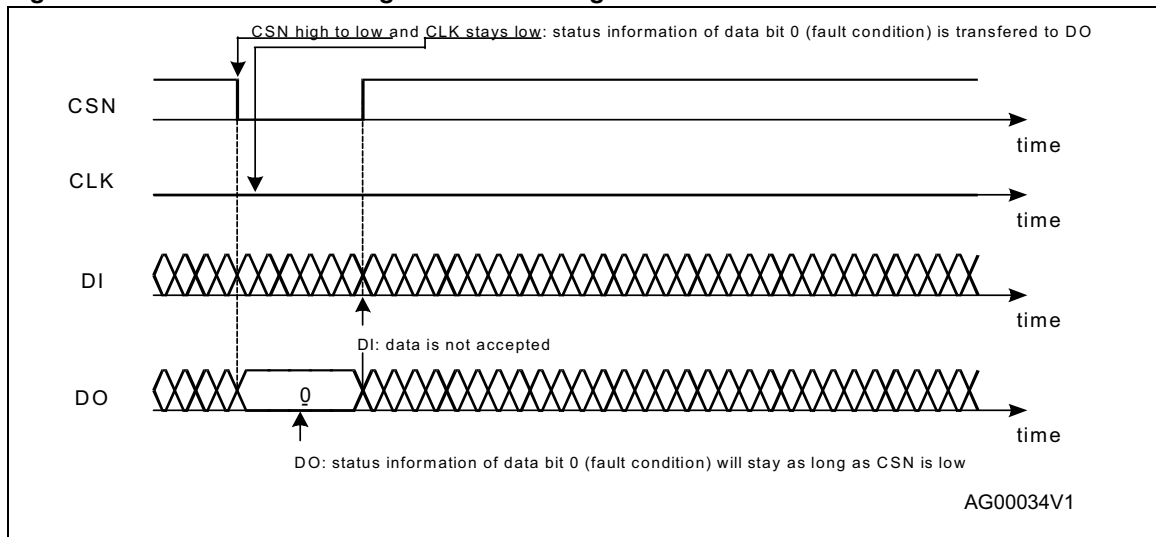

Figure 35. SPI – CSN low to high transition and global status bit access



6 ST SPI

6.1 SPI communication flow

6.1.1 General description

The proposed SPI communication is based on a standard SPI interface structure using CSN (Chip Select Not), SDI (Serial Data In), SDO (Serial Data Out/Error) and SCK (Serial Clock) signal lines.

At device start-up the master reads the *<SPI-frame-ID>* register (ROM address 3EH) of the slave device. This 8-bit register indicates the SPI frame length (24bit) and the availability of additional features.

Each communication frame consists of an instruction byte which is followed by 2 data bytes.

The data returned on SDO within the same frame always starts with the *<Global Status>* register. It provides general status information about the device. It is followed by 2 data bytes (i. e. 'In-frame-response').

For write cycles the *<Global Status>* register is followed by the previous content of the addressed register.

For read cycles the *<Global Status>* register is followed by the content of the addressed register.

A write command is only accepted as a valid command by the device if the counted number of clocks is exact 24, otherwise the command is rejected.

Command byte

Each communication frame starts with a command byte. It consists of an operating code which specifies the type of operation (*<Write>*, *<Read>*, *<Read and Clear>*, *<Read Device Information>*) and a 6 bit address. If less than 6 address bits are required, the remaining bits are unused but are reserved.

Table 44. Command byte

MSB								LSB
Op code		Address						
OC1	OC0	A5	A4	A3	A2	A1	A0	

OCx: operating code

Ax: address

6.1.2 Operating code definition

Table 45. Operating code definition

OC1	OC0	Meaning
0	0	<i><Write Mode></i>
0	1	<i><Read Mode></i>

Table 45. Operating code definition (continued)

OC1	OC0	Meaning
1	0	<Read and Clear Status>
1	1	<Read Device Information>

The <Write Mode> <Read Mode> and <Read and Clear Status> operations allow access to the RAM of the device, i. e. to write to control registers or read status information.

A <Read and Clear Status> operation addressed to a device specific status register reads back and subsequently clear this status register.

A <Read and Clear Status> operation with address 3FH clears all status registers (including the Global Status Register). Configuration register is read by this operation.

<Read Device Information> allows access to the ROM area which contains device related information such as the product family, product name, silicon version, register width and availability of a watchdog.

More detailed descriptions of the device information are available in 'Read Device Information'.

6.1.3 Global status register^(d)

Table 46. Global status register

Bit 7	Bit 6	Bit 5	Bit 4	Bit 3	Bit 2	Bit 1	Bit 0
Global error flag (GEF)	Comm error	Not (chip reset OR comm error)	TSD2	TSD1	V ₁ Fail	VS Fail (OV/UV)	Fail safe

6.1.4 Configuration register

The <Configuration> register is accessible at RAM address 3FH.

For the config register, the 8 bits are located in the low byte (LSB).

The configuration register is implemented for compliance purpose to ST SPI standard.

Table 47. Configuration register

Bit 7	Bit 6	Bit 5	Bit 4	Bit 3	Bit 2	Bit 1	Bit 0
0	0	0	0	0	0	0	WD trigger

<WD trigger>: this bit is reserved to serve the watchdog.

d. See [Section 6.2](#) for details.

Figure 36. Read configuration register⁽¹⁾

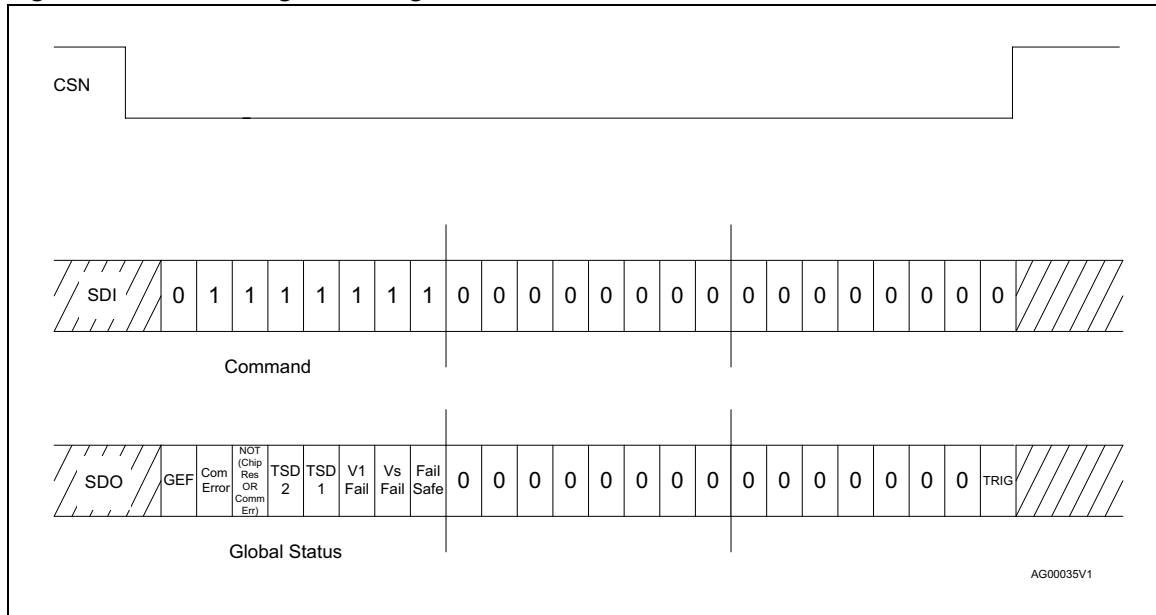

1. The configuration register is implemented for compliance with ST standard SPI 3.0 and contains only the watchdog trigger bit at D0

Figure 37. Write configuration register⁽¹⁾

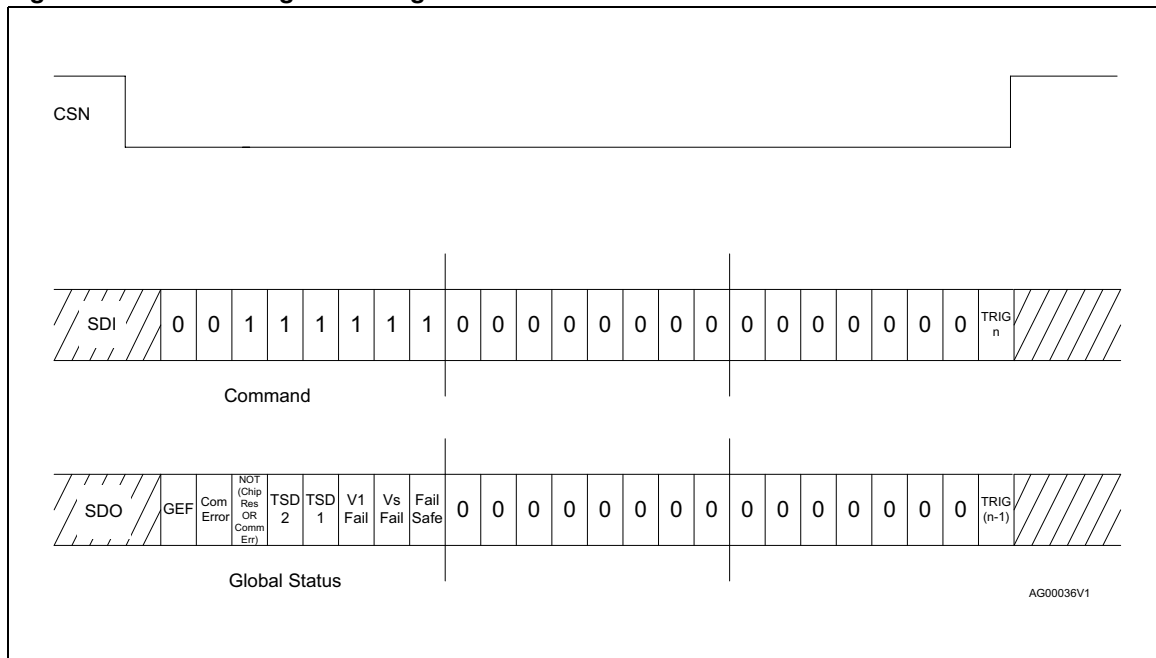

1. The configuration register is implemented for compliance with ST standard SPI 3.0 and contains only the watchdog trigger bit at D0

6.1.5 Address mapping

Table 48. Address mapping

RAM address	Description	Access
3FH	<Configuration>	R/W
13H	Status register 3	R
12H	Status register 2	R
11H	Status register 1	R
06H	Control register 6	R/W
05H	Control register 5	R/W
04H	Control register 4	R/W
03H	Control register 3	R/W
02H	Control register 2	R/W
01H	Control register 1	R/W
00H	Reserved	R/W

ROM address	Description	Access
3FH	Reserved	N/A
3EH	<SPI frame ID>	R
...	Unused	N/A
03H	<product code 2>	N/A
02H	<product code 1>	R
01H	<silicon version>	R
00H	<ID Header>	R

The RAM memory area consists of 16 bit registers.

For the device information (ROM memory area) the eight most significant bits of the memory cell are used. The remaining 8 are zero.

All unused RAM and ROM addresses is read as '0'.

- Note:*
- 1 The register definition for RAM address 00H is unused. A register value of all 0 must cause the device to enter a fail-safe state (interpreted as 'SDI stuck to GND' failure).
 - 2 ROM address 3FH is unused. An attempt to access this address must be recognized as a communication error ('SDI stuck to V_{CC} ' failure) and must cause the device to enter a fail-safe state.

6.1.6 Write operation

The write operation starts with a command byte followed by 2, data bytes. The number of data bytes is specified in the <SPI-frame-ID>.

Write command format

Table 49. Write command format: command byte

MSB								LSB
Op Code		Address						
0	0	A5	A4	A3	A2	A1	A0	

Table 50. Write command format: data byte 1

MSB							LSB
D15	D14	D13	D12	D11	D10	D9	D8

Table 51. Write command format: data byte 2

MSB							LSB
D7	D6	D5	D4	D3	D2	D1	D0

OC0, OC1:operating code (00 for 'write' mode)

A0 to A5:address bits

An attempt to write 00H at RAM address 00H is recognized as a failure (SDI stuck to GND). The device enters a fail-safe state.

6.1.7 Format of data shifted out at SDO during write cycle

Table 52. Format of data shifted out at SDO during write cycle: global status register

Bit 7	Bit 6	Bit 5	Bit 4	Bit 3	Bit 2	Bit 1	Bit 0
Global error flag (GEF)	Comm error	Not (chip reset or comm error)	TSD2	TSD1	V ₁ Fail	V _S Fail (OV/UV)	Fail safe

Table 53. Format of data shifted out at SDO during write cycle: data byte 1

MSB	Previous content of addressed register						LSB
D15	D14	D13	D12	D11	D10	D9	D8

Table 54. Format of data shifted out at SDO during write cycle: data byte 2

MSB	Previous content of addressed register						LSB
D7	D6	D5	D4	D3	D2	D1	D0

Failures are indicated by activating the corresponding bit of the <Global Status> register.

The returned data byte(s) represent(s) the previous content of the accessed register.

Figure 38. Format of data shifted out at SDO during write cycle

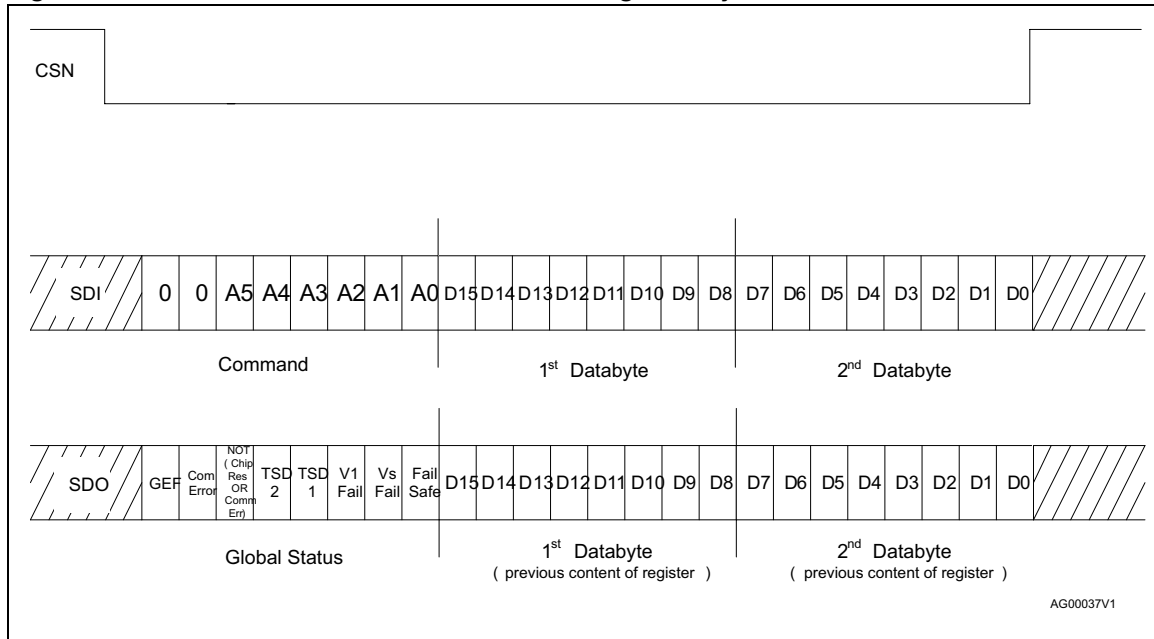

6.1.8 Read operation

The read operation starts with a command byte followed by 2 data bytes. The number of data bytes is specified in the *<SPI-frame-ID>*. The content of the data bytes is 'don't care'. The content of the addressed register is shifted out at SDO within the same frame ('in-frame response').

Read command format

Table 55. Read command format: command byte

MSB								LSB
Op Code		Address						
0	1	A5	A4	A3	A2	A1	A0	

Table 56. Read command format: data byte 1

MSB								LSB
0	0	0	0	0	0	0	0	

Table 57. Read command format: data byte 2

MSB								LSB
0	0	0	0	0	0	0	0	

OC0, OC1: operating code (01 for 'read' mode)

A0 to A5:address bits

6.1.9 Format of data shifted out at SDO during read cycle

Table 58. Format of data shifted out at SDO during read cycle: global status register

Bit 7	Bit 6	Bit 5	Bit 4	Bit 3	Bit 2	Bit 1	Bit 0
Global error flag (GEF)	Comm error	Not (chip reset or comm error)	TSD2	TSD1	V ₁ Fail	V _S Fail (OV/UV)	Fail safe

Table 59. Format of data shifted out at SDO during read cycle: data byte 1

MSB	Previous content of addressed register						LSB
D15	D14	D13	D12	D11	D10	D9	D8

Table 60. Format of data shifted out at SDO during read cycle: data byte 2

MSB	Previous content of addressed register						LSB
D7	D6	D5	D4	D3	D2	D1	D0

Failures are indicated by activating the corresponding bit of the <Global Status> register.

The returned data byte(s) represent(s) the content of the register to be read.

Figure 39. Format of data shifted out at SDO during read cycle

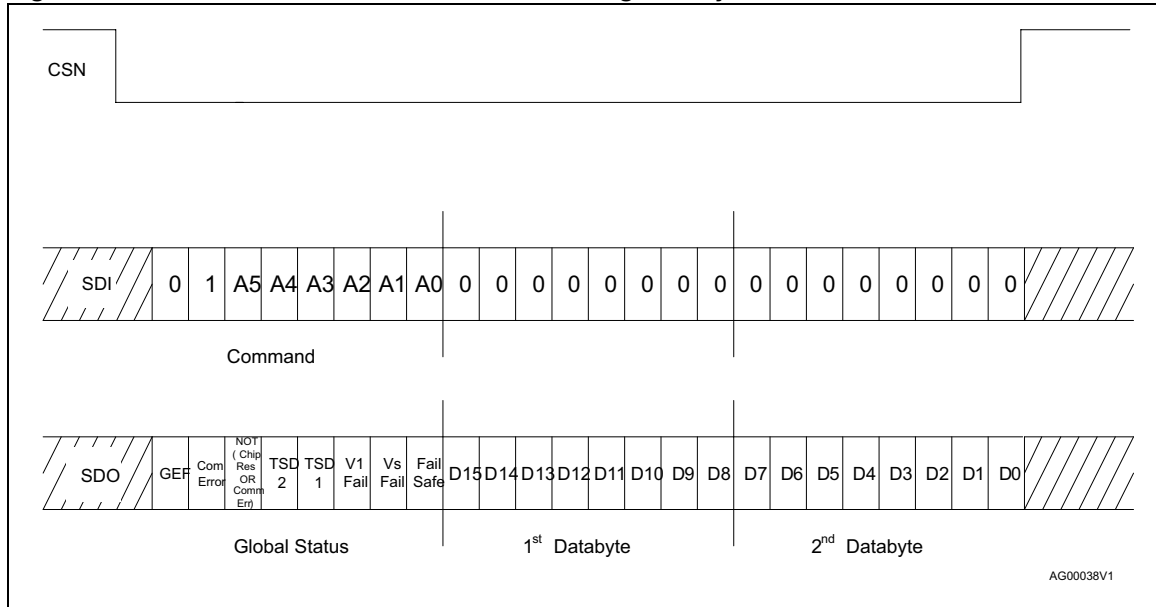

6.1.10 Read and clear status operation

The 'Read and Clear Status' operation starts with a command byte followed 2 data bytes. The number of data bytes is specified in the <SPI-frame-ID>. The content of the data bytes is 'don't care'. The content of the addressed status register is transferred to SDO within the same frame ('in-frame response') and is subsequently cleared.

A 'Read and Clear Status' operation with address 3FH clears all status registers (incl. the <Global Status> register). The configuration register is read by this operation.

Read and clear status command format

Table 61. Read and clear status command format: command byte

MSB								LSB
Op Code		Address						
1	01	A5	A4	A3	A2	A1	A0	

Table 62. Read and clear status command format: data byte 1

MSB								LSB
0	0	0	0	0	0	0	0	

Table 63. Read and clear status command format: data byte 2

MSB								LSB
0	0	0	0	0	0	0	0	

OC0, OC1: operating code (10 for 'read and clear status' mode)

A0 to A5: address bits

Format of data shifted out at SDO during read and clear status operation

Table 64. Format of data shifted out at SDO during read and clear status: global status register

Bit 7	Bit 6	Bit 5	Bit 4	Bit 3	Bit 2	Bit 1	Bit 0
Global error flag (GEF)	Comm error	Not (chip reset or comm error)	TSD2	TSD1	V ₁ Fail	V _S Fail (OV/UV)	Fail safe

Table 65. Format of data shifted out at SDO during read and clear status: data byte 1

MSB		Previous content of addressed register						LSB
D15	D14	D13	D12	D11	D10	D9	D8	

Table 66. Format of data shifted out at SDO during read and clear status: data byte 2

MSB	Previous content of addressed register						LSB
D7	D6	D5	D4	D3	D2	D1	D0

Failures are indicated by activating the corresponding bit of the <Global Status> register.

The returned data byte(s) represent(s) the content of the register to be read.

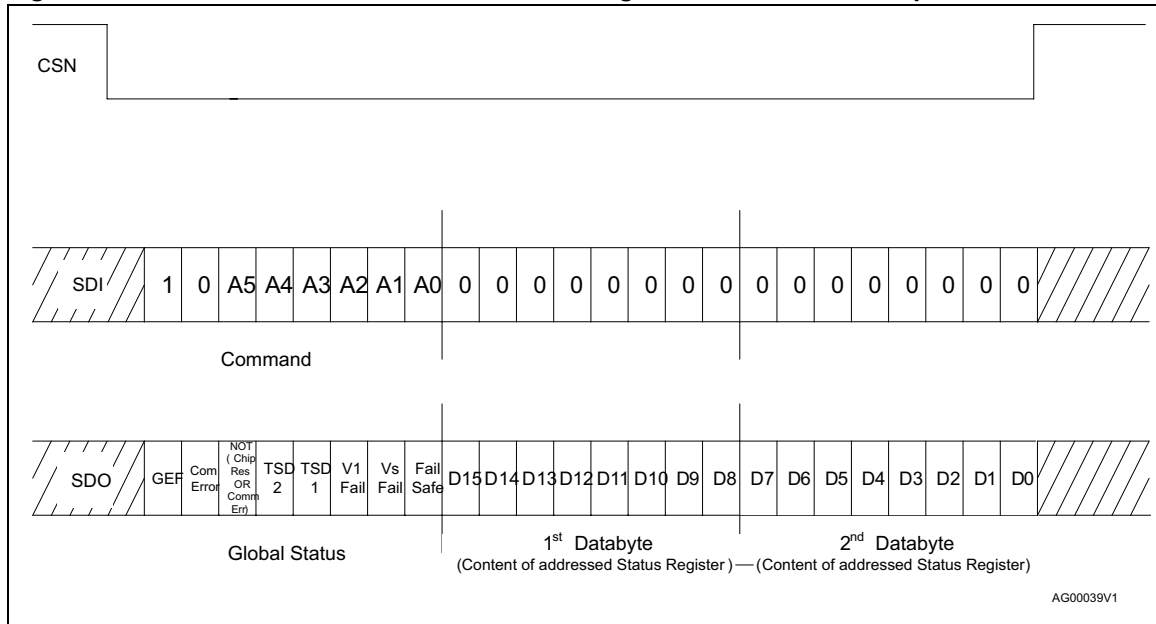
Figure 40. Format of data shifted out at SDO during read and clear status operation

6.1.11 Read device information

The device information is stored at the ROM addresses defined below and is read using the respective operating code.

Table 67. Read device information

Op code		ROM address	Device information	Value
OC1	OC0			
1	1	3FH	Reserved	00
1	1	3EH	<SPI frame ID> includes frame width and availability of watchdog	42 Hex
1	1	04H to 3DH	unused	00
1	1	03H	<product code 2> unique product identifier	4B Hex

Table 67. Read device information (continued)

Op code		ROM address	Device information	Value
OC1	OC0			
1	1	02H	<product code 1> unique product identifier	13 Hex
1	1	01H	<silicon version> indicates Design Version	According to silicon version
1	1	00H	<ID Header> device family max address of device information	43 Hex

The <ID-Header> (ROM address 00H) indicates the product family and specifies the highest address which contains product information

Table 68. ID-header

Bit 7	Bit 6	Bit 5	Bit 4	Bit 3	Bit 2	Bit 1	Bit 0
0	1	0	0	0	0	1	1
Family Identifier		Highest address containing device information					

<Family Identifier>:01 Hex (BCD)

<Highest address>:03 Hex

Table 69. Family identifier

Bit 7	Bit 6	Meaning
0	0	VIpower
0	1	BCD
1	0	VIpower hybrid
1	1	Tbd

The <Product Code 1> (ROM address 02H) and <Product Code 2> (ROM address 03H) represents a unique code to identify the product name.

<Product Code 1> 13 Hex

<Product Code 2> 4B Hex

The <Silicon Version> (ROM address 01H) provides information about the silicon version according to the table below:

Table 70. Silicon version identifier

Bit 7	Bit 6	Bit 5	Bit 4	Bit 3	Bit 2	Bit 1	Bit 0
Reserved				Silicon version			

The <SPI-frame-ID> (ROM address 3EH) provides information about the register width (1, 2, 3 bytes) and the availability of 'Burst Mode Read' and watchdog.

Table 71. SPI-frame-ID

Bit 7	Bit 6	Bit 5	Bit 4	Bit 3	Bit 2	Bit 1	Bit 0
0	1	0	0	0	0	1	0
BR	WD	X	X	X	32-bit	24-bit	16-bit

BR:burst-mode read (1 = burst-mode read is supported)

WD:watchdog (1 = available, 0 = not available)

32-bit, 24-bit, 16-bit: width of SPI frame (see table below)

<Burst Mode>:not supported

<Watchdog>:available

<Frame Width>:24 bit

6.2 SPI registers

6.2.1 Overview

Overview command byte

Table 72. SPI register: command byte

Read/write		Address					
x	x	x	x	x	x	x	x

Table 73. SPI register: mode selection

Read/write		Mode selection
0	0	Write
0	1	Read
1	0	Read and clear
1	1	Read device info

Table 74. SPI register: CTRL register selection

CTRL register 1..6						CTRL register selection
0	0	0	0	0	1	CTRL register1
0	0	0	0	1	0	CTRL register2
0	0	0	0	1	1	CTRL register3
0	0	0	1	0	0	CTRL register4

Table 74. SPI register: CTRL register selection (continued)

CTRL register 1..6						CTRL register selection
0	0	0	1	0	1	CTRL register5
0	0	0	1	1	0	CTRL register6

Table 75. SPI register: STAT register selection

STAT register. 1..3						STAT register selection
0	1	0	0	0	1	STAT register1
0	1	0	0	1	0	STAT register2
0	1	0	0	1	1	STAT register3

Overview of control register data bytes

6.2.2 Control registers

Table 76. Overview of control registers data bytes

	1 st data byte <15:8>								2 nd data byte <7:0>							
Control register 1, data																
Defaults	0	0	0	0	0	0	0	0	0	0	0	0		0	0	0
Function	OUT HS	OUT HS	OUT 4	OUT 4	OUT HS_EXT	OUT 3	OUT 2	OUT 1	REL 2	REL 1	V ₂	V ₂	Res	Stby sel	Go Stby	Trig
Group	HS control								LS Output, V ₂ and mode control							
Control register 2, data																
Defaults			0	0	0	0	0	0	0	0	0	0		1	1	1
Function	Res	Res	Inp. Filt 3	Inp. Filt 3	Inp. Filt 2	Inp. Filt 2	Inp. Filt 1	Inp. Filt 1	Res	Input Pu/Pd 3	Input Pu/Pd 2	Input Pu/Pd 1	Res	WU EN 3	WU EN 2	WU EN 1
Group	Wake-up control								Wake-up control							
Control register 3, data																
Defaults		0	0	0		0	0	0			0	0	1	1	0	0
Function	Res	T1 On	T1 Per	T1 Per	Res	T2 On	T2 Per	T2 Per	Res	Res	WD time	WD time	LIN WU En	CAN WU En	Wake timer En	Wake Timer Select
Group	Timer Settings								Watchdog and cyclic wake up settings							
Control register 4, data																
Defaults		0	0	1		1	0	0	1	1	1	1	0	1	1	0
Function	Res	I _{COMP}	OutHS Rec En	Vlock Out En	Res	LS OV/UV shut down_en	V ₁ Reset Level	V ₁ Reset Level	LIN Pu En	Res	Lin TxD Tout En	CAN ACT	CAN Loop En	CAN Patt. wake En	CAN split On	CAN Rec Only
Group	Control (other)								Transceiver settings							
Control register 5, data																
Defaults		1	1	1	1	1	1	1	0	0	0	0	0	0	0	0
Function	Res	PWM2 Off-DC	PWM2 Off-DC	PWM2 Off-DC	PWM2 Off-DC	PWM2 Off-DC	PWM2 Off-DC	PWM2 Off-DC	PWM Freq	PWM1 ON-DC	PWM1 ON-DC	PWM1 ON-DC	PWM1 ON-DC	PWM1 ON-DC	PWM1 ON-DC	PWM1 ON-DC
Group	PWM2 setting								PWM1 setting							
Control register 6, data																
Defaults		1	1	1	1	1	1	1		0	0	0	0	0	0	0
Function	Res	PWM4 Off-DC	PWM4 Off-DC	PWM4 Off-DC	PWM4 Off-DC	PWM4 Off-DC	PWM4 Off-DC	PWM4 Off-DC	Res	PWM3 ON-DC	PWM3 ON-DC	PWM3 ON-DC	PWM3 ON-DC	PWM3 ON-DC	PWM3 ON-DC	PWM3 ON-DC
Group	PWM4 setting								PWM3 setting							

Control register 1

Table 77. Control register 1: command and data bytes

Command byte								1 st data byte	2 nd data byte
Read/write		Address							
x	x	0	0	0	0	0	1	Data, 8bit	Data, 8 bit

Table 78. Control register 1, data bytes

	1 st data byte <15:8>								2 nd data byte <7:0>							
Defaults	0	0	0	0	0	0	0	0	0	0	0	0	0	0	0	0
Function	OUT HS_2	OUT HS_1	OUT 4_2	OUT 4_1	OUT HS_EXT	OUT 3	OUT 2	OUT 1	REL 2	REL 1	V _{2_2}	V _{2_1}	Res	Stby sel	Go Stby	Trig
Group	HS control								LS Output, V ₂ and mode control							

Table 79. Control register 1, bits

Bit	Name	Comment				
15	OUTHS	Select mode of OUTHS				
14		OUTHS_EXT	OUTHS_2	OUTHS_1	Mode	
		0	0	0	HS off	
		0	0	1	HS cyclic on with timer 1	
		0	1	0	HS controlled by PWM4	
		0	1	1	HS cyclic on with Timer 2	
		1	1	0	PWM3	
1	x	1	HS on			
13	OUT4	Select mode of OUT4				
12		OUT4_2	OUT4_1	Mode		
		0	0	HS off		
		0	1	HS on		
		1	0	HS controlled by PWM4		
1	1	HS cyclic on with Timer 2				
11	OUTHS_EXT	Extended function of OUTHS; see table OUTHS				

Table 79. Control register 1, bits (continued)

Bit	Name	Comment		
10	OUT3	Select mode of OUT3		
		OUT3		Mode
		0	Select FSO	Active and standby mode
		1	Select PWM3	
9	OUT2	Select mode of OUT2		
		OUT2		Mode
		0	Select PWM2	Active and standby mode
		1	Select timer2	
8	OUT1	Select mode of OUT1		
		OUT1		Mode
		0	Select PWM1	Active and standby mode
		1	Select timer1	
7	REL2	Select mode of REL2		
		REL2		Mode
		0	REL2 off	Active and standby mode
		1	REL2 on	Active mode
6	REL1	Select mode of REL1		
		REL1		Mode
		0	REL1 off	Active and standby mode
		1	REL1 on	Active mode

Table 79. Control register 1, bits (continued)

Bit	Name	Comment		
5	V ₂			
4		V _{2_2}	V _{2_1}	
		0	0	V ₂ OFF in all modes
		0	1	V ₂ ON in active mode; OFF in V ₁ /V _{BAT} standby mode
		1	0	V ₂ ON in Active/V ₁ standby mode; OFF in V _{BAT} standby mode
		1	1	V ₂ ON in all modes
3	RES	Reserved		
2	STBY_SEL	Select standby mode		
		0	V _{BAT} standby mode	
		1	V ₁ standby mode	
1	GO_STBY	Execute standby mode		
		0	No action	
		1	Execute standby mode	
0	TRIG	Trigger Bit for Watchdog		

Control register 2**Table 80. Control register 2: command and data bytes**

Command byte								1 st data byte	2 nd data byte
Read/write				Address					
x	x	0	0	0	0	1	0	Data, 8bit	Data, 8 bit

Table 81. Control register 2, data bytes

		1 st data byte <15:8>						2 nd data byte <7:0>								
Defaults		0	0	0	0	0	0		0	0	0		1	1	1	
Function	Res	Res	Wu3 Filt_MSB	Wu3 Filt_LSB	WU2 Filt_MSB	WU2 Filt_LSB	WU1 Filt_MSB	WU1 Filt_LSB	Res	WU3 Pu/Pd	WU2 Pu/Pd	WU1 Pu/Pd	Res	WU3 EN	WU2 EN	WU1 EN
Group	Wakeup control						Wakeup control									

Table 82. Control register 2, bits

Bit	Name	Comment			
15	Res	Reserved			
14	Res	Reserved			
13, 12	WU3_Filt	Wakeup filter configuration			
11, 10	WU2_Filt	MSB	LSB		
9, 8	WU1_Filt	0	0	Static, 64 μ s	
		0	1	Enabled with timer 2; 80 μ s blank	
		1	0	Enabled with timer 2; 800 μ s blank	
		1	1	Enabled with timer 1; 800 μ s blank	
7	Res	Reserved			
6	WU3_Pu/Pd	Pull up or pull down configuration			
5	WU2_Pu/Pd	0	Pull down		
4	WU1_Pu/Pd	1	Pull up		
3	Res	Reserved			
2	WU3_EN	Enable Wake up source			
1	WU2_EN	0	Disable		
0	WU1_EN	1	Enable		

Control register 3**Table 83. Control register 3: command data bytes**

Command byte								1 st data byte	2 nd data byte
Read/write		Address							
x	x	0	0	0	0	1	1	Data, 8bit	Data, 8 bit

Table 84. Control register 3, data bytes

	1 st data byte <15:8>								2 nd data byte <7:0>							
Defaults		0	0	0	0	0	0	0			0	0	1	1	0	0
Function	Res	T1 On	T1 Per MSB	T1 Per LSB	Res	T2 On	T2 Per MSB	T2 Per LSB	Res	Res	WD time MSB	WD time LSB	LIN WU En	CAN WU En	Wake timer En	Wake timer select
Group	Timer Settings								Watchdog and cyclic wake up settings							

Table 85. Control register 3, bits

Bit	Name	Comment															
15	RES	Reserved															
14	T1_On	Timer 1 "ON" time selections <table border="1" data-bbox="532 401 761 485"> <tr> <td>0</td> <td>10 ms</td> </tr> <tr> <td>1</td> <td>20 ms</td> </tr> </table>	0	10 ms	1	20 ms											
0	10 ms																
1	20 ms																
13	T1_Per_MSB	Timer 1 period selection															
12	T1_Per_LSB	<table border="1" data-bbox="532 611 911 833"> <thead> <tr> <th>MSB</th> <th>LSB</th> <th></th> </tr> </thead> <tbody> <tr> <td>0</td> <td>0</td> <td>1 s</td> </tr> <tr> <td>0</td> <td>1</td> <td>2 s</td> </tr> <tr> <td>1</td> <td>0</td> <td>3 s</td> </tr> <tr> <td>1</td> <td>1</td> <td>4 s</td> </tr> </tbody> </table> Timer 1 is restarted with a valid write command to control register 3	MSB	LSB		0	0	1 s	0	1	2 s	1	0	3 s	1	1	4 s
MSB	LSB																
0	0	1 s															
0	1	2 s															
1	0	3 s															
1	1	4 s															
11	Res																
10	T2_On	Timer 2 "ON" time selection <table border="1" data-bbox="532 961 761 1045"> <tr> <td>0</td> <td>0.1 ms</td> </tr> <tr> <td>1</td> <td>1 ms</td> </tr> </table>	0	0.1 ms	1	1 ms											
0	0.1 ms																
1	1 ms																
9	T2_Per_MSB	Timer 2 period selection															
8	T2_Per_LSB	<table border="1" data-bbox="532 1171 911 1394"> <thead> <tr> <th>MSB</th> <th>LSB</th> <th></th> </tr> </thead> <tbody> <tr> <td>0</td> <td>0</td> <td>10 ms</td> </tr> <tr> <td>0</td> <td>1</td> <td>20 ms</td> </tr> <tr> <td>1</td> <td>0</td> <td>50 ms</td> </tr> <tr> <td>1</td> <td>1</td> <td>200 ms</td> </tr> </tbody> </table> Timer 2 is restarted with a valid write command to control register 3	MSB	LSB		0	0	10 ms	0	1	20 ms	1	0	50 ms	1	1	200 ms
MSB	LSB																
0	0	10 ms															
0	1	20 ms															
1	0	50 ms															
1	1	200 ms															
7	Res	Reserved															
6	Res	Reserved															

Table 85. Control register 3, bits (continued)

Bit	Name	Comment					
5	WD_time_MSB	Trigger window selection					
4	WD_time_LSB						
					MSB	LSB	
					0	0	10 ms
					0	1	50 ms
					1	0	100 ms
		1	1	200 ms			
3	LIN_WU_En	Enable LIN as wake up source					
		0	Disabled				
		1	Enabled				
2	CAN_WU_En	Enable CAN as wake up source					
		0	Disabled				
		1	Enabled				
1	Wake_timer_En	Enable wake up by timer from V ₁ standby mode (Interrupt) or V _{BAT} standby Mode (Nreset)					
		0	Disabled				
		1	Enabled				
0	Wake_timer_select	Timer selection for timer interrupt / wake-up of μ C by timer					
		0	Timer 2				
		1	Timer 1				

Control register 4**Table 86. Control register 4: command and data bytes**

Read/Write		Command byte							1 st data byte	2 nd data byte
		Address								
x	x	0	0	0	1	0	0	Data, 8bit	Data, 8 bit	

Table 87. Control register 4, data bytes

	1 st data byte <15:8>								2 nd data byte <7:0>							
Defaults		0	0	1	0	1	0	0	1	1	1	1	0	1	1	0
Function	RES	I _{CMP}	OutHS Rec En	Vlock Out_en	RES	LS OV/UV shut down_en	V ₁ Reset Lev_2	V ₁ Reset Lev_1	LIN Pu En	Res	Lin TxD Tout En	CAN ACT	CAN Loop En	CAN Patt. wake En	CAN split On	CAN Rec only
Group	Control (other)								Transceiver settings							

Table 88. Control register 4, bits

Bit	Name	Comment	
15	Res	Reserved; must be set to zero	
14	I _{cmp}	V ₁ load current supervision	
		0	Enabled; Watchdog is disabled in V ₁ Standby when the V _{1loadcurrent} < I _{cmpthreshold}
		1	Disabled; Watchdog is automatically disabled when V ₁ standby is entered
13	OUTHS_rec_en	Overcurrent Auto recovery mode for OUTHS	
		0	Disabled
		1	Enabled
12	Vlock_out_en	Voltage lock out: OV/UV status	
		0	Over/under voltage status recovers automatically when condition disappears
		1	Over/under voltage status is latched until a read and clear command is performed
11	Res	Reserved	
10	LS_OV/UV shut_down_en	Shutdown of low-side drivers in case of over-/under voltage	
		0	No shutdown of low-sides in case of over/under voltage
		1	Shutdown low-sides in case of over/under voltage

Table 88. Control register 4, bits (continued)

Bit	Name	Comment		
9	V1Reset_level_1	Select reset level		
8	V1Reset_level_2			
		V1RSTlev_2	V1RSTlev_1	V1 reset level
		0	0	4.6 V
		0	1	4.35 V
		1	0	4.1 V
		1	1	3.8 V
7	LIN_PU_EN	Enable internal Lin pull up		
		0	No LIN master pull-up	
		1	LIN master pull-up	
6	Res	Must be written to '1'		
5	Lin_TxD_Tout_En	Enable / disable monitoring via TxD		
		0	No TxD monitoring	
		1	TxD monitoring; LIN transmitter is switched off if TXDL is dominant for t > 12 ms	
4	CAN_ACT	Activate CAN transceiver		
		0	CAN transceiver deactivated	Active mode
		1	CAN transceiver activated	
3	CAN_Loop_En	Enable looping of CANTX to CANRXD		
		0	No looping	
		1	TXDC is looped to RXDC	
2	CAN_Patt_wake_En	Enable pattern wake up for CAN		
		0	No pattern wake up	
		1	Pattern wake up	
1	CAN_split_On	Enable SPLIT termination for CAN		
		0	Split termination disabled	Active mode
		1	Split termination enabled	

Table 88. Control register 4, bits (continued)

Bit	Name	Comment		
0	CAN_Rec_only	Enable CAN receive only mode		
		0	CAN in transceiver mode	Active mode
		1	CAN in receive only mode	

Control register 5**Table 89. Control register 5: command and data bytes**

Command byte								1 st data byte				2 nd data byte			
Read/write				Address											
x	x	0	0	0	1	0	1	Data, 8bit				Data, 8 bit			

Table 90. Control register 5, data bytes

		1 st data byte <15:8>								2 nd data byte <7:0>							
Defaults		1	1	1	1	1	1	1	1	0	0	0	0	0	0	0	0
Function	Res	PWM2 Off-DC	PWM2 Off-DC	PWM2 Off-DC	PWM2 Off-DC	PWM2 Off-DC	PWM2 Off-DC	PWM2 Off-DC	PWM2 Off-DC	PWM Freq	PWM1 ON-DC	PWM1 ON-DC	PWM1 ON-DC	PWM1 ON-DC	PWM1 ON-DC	PWM1 ON-DC	PWM1 ON-DC
Group		PWM2 setting								PWM1 setting							

Table 91. Control register 5, bits

Bit	Name	Comment									
15	RES	Reserved; must be set to zero									
14	PWM2_Off_DC_6										
13	PWM2_Off_DC_5	PWM2 OFF_DC_6	PWM2 OFF_DC_5	PWM2 OFF_DC_4	PWM2 OFF_DC_3	PWM2 OFF_DC_2	PWM2 OFF_DC_1	PWM2 OFF_DC_0	PWM duty cycle		
12	PWM2_Off_DC_4	1	1	1	1	1	1	1	0%, HS OFF		
11	PWM2_Off_DC_3	...									
10	PWM2_Off_DC_2	0	0	0	0	0	1	0	98.5%		
9	PWM2_Off_DC_1	0	0	0	0	0	0	1	99.25%		
8	PWM2_Off_DC_0	0	0	0	0	0	0	0	100% HS ON		

Table 91. Control register 5, bits (continued)

Bit	Name	Comment							
7	PWM_FREQ	Select PWM frequency							
		0	128 Hz						
		1	256 Hz						
6	PWM1_ON_DC_6								
5	PWM1_ON_DC_5	PWM1_ON_DC_6	PWM1_ON_DC_5	PWM1_ON_DC_4	PWM1_ON_DC_3	PWM1_ON_DC_2	PWM1_ON_DC_1	PWM1_ON_DC_0	PWM duty cycle
4	PWM1_ON_DC_4	1	1	1	1	1	1	1	100%, HS ON
3	PWM1_ON_DC_3	...							
2	PWM1_ON_DC_2	0	0	0	0	0	1	0	1.5%
1	PWM1_ON_DC_1	0	0	0	0	0	0	1	0.75%
0	PWM1_ON_DC_0	0	0	0	0	0	0	0	0% HS OFF

Control register 6

Table 92. Control register 6: command and data bytes

Command byte								1 st data byte	2 nd data byte
Read/Write		Address							
x	x	0	0	0	1	1	0	Data, 8bit	Data, 8 bit

Table 93. Control register 6, data bytes

		1 st data byte <15:8>						2 nd data byte <7:0>								
Defaults		1	1	1	1	1	1		0	0	0	0	0	0	0	
Function	Res	PWM4 Off_DC_6	PWM4 Off_DC_5	PWM4 Off_DC_4	PWM4 Off_DC_3	PWM4 Off_DC_2	PWM4 Off_DC_1	PWM4 Off_DC_0	Res	PWM3 ON_DC_6	PWM3 ON_DC_5	PWM3 ON_DC_4	PWM3 ON-DC_3	PWM3 ON_DC_2	PWM3 ON_DC_1	PWM3 ON_DC_0
Group		PWM4 setting						PWM3 setting								

Table 94. Control register 6, bits

Bit	Name	Comment							
15	RES	Reserved; must be set to zero							
14	PWM4_Off_DC_6								
13	PWM4_Off_DC_5	PWM4 OFF_DC_6	PWM4 OFF_DC_5	PWM4 OFF_DC_4	PWM4 OFF_DC_3	PWM4 OFF_DC_2	PWM4 OFF_DC_1	PWM4 OFF_DC_0	PWM4 duty cycle
12	PWM4_Off_DC_4	1	1	1	1	1	1	1	0%, HS OFF
11	PWM4_Off_DC_3	...							
10	PWM4_Off_DC_2	0	0	0	0	0	1	0	98.5%
9	PWM4_Off_DC_1	0	0	0	0	0	0	1	99.25%
8	PWM4_Off_DC_0	0	0	0	0	0	0	0	100% HS ON
7	RES	Reserved; must be set to zero							
6	PWM3_ON_DC_6								
5	PWM3_ON_DC_5	PWM3 ON_DC_6	PWM3 ON_DC_5	PWM3 ON_DC_4	PWM3 ON_DC_3	PWM3 ON_DC_2	PWM3 ON_DC_1	PWM3 ON_DC_0	PWM3 duty cycle
4	PWM3_ON_DC_4	1	1	1	1	1	1	1	100%, HS ON
3	PWM3_ON_DC_3	...							
2	PWM3_ON_DC_2	0	0	0	0	0	1	0	1.5%
1	PWM3_ON_DC_1	0	0	0	0	0	0	1	0.75%
0	PWM3_ON_DC_0	0	0	0	0	0	0	0	0% HS OFF

6.2.3 Status registers

Table 95. Overview of status register data bytes

	1 st data byte <15:8>								2 nd data byte <7:0>							
Status register 1, data <15:0>																
Function	OL HS	OL OUT4	OL OUT3	OL OUT2	OL OUT1	UV	V ₂ fail	V ₂ short	OV	OC HS	OC Out4	OC Out3	OC Out2	OC Out1	OC Rel2	OC Rel1
Group	Diagnosis 1								Diagnosis 2							
Status register 2, data <15:0>																
Function	WU3 state	WU2 state	WU1 state	WU3 wake	WU2 wake	WU1 Wake	Wake CAN	Wake LIN	Wake Timer int	LIN perm. dom.	LIN TxD perm dom.	LIN perm. rec.	CAN RxD perm rec.	CAN perm. rec.	CAN perm. dom.	CAN TxD perm dom
Group	Diagnosis 3								Diagnosis 4							
Status register 3, data <15:0>																
Function	TSD1	TW	Device state	Device state	V ₁ fail	V ₁ restart	V ₁ restart	V ₁ restart	WD fail	WD fail	WD fail	WD fail	Forced sleep WD	Forced sleep TSD2 SHTV1	WD timer state	WD timer state
Group	Diagnosis 5								Diagnosis 6							

Table 96. Global status register

	Bit 7	Bit 6	Bit 5	Bit 4	Bit 3	Bit 2	Bit 1	Bit 0	Hex value
	Global error flag ⁽¹⁾	Communication error ⁽²⁾	NOT (chip reset or comm. error) i.e. cold start ⁽³⁾	TSD2 ⁽⁴⁾	TSD1	V ₁ Fail	V _s fail ⁽⁵⁾ (OV/UV)	Fail safe ⁽⁶⁾	
Active high/low	High	High	Low	High	High	High	High	High	
Default value in normal mode - after correct WD trigger or after read & clear on error flags	0	0	1	0	0	0	0	0	20
Power ON	1	0	0	0	0	0	0	0	80
Power ON weak battery ⁽⁷⁾	1	0	0	0	0	0	1	0	82
Communication error	1	1	0	0	0	0	0	0	C0
V _s over or under-voltage	1	0	1	0	0	0	1	0	A2
WD failure	1	0	1	0	0	0	0	1	A1

Table 96. Global status register (continued)

	Bit 7	Bit 6	Bit 5	Bit 4	Bit 3	Bit 2	Bit 1	Bit 0	Hex value
	Global error flag ⁽¹⁾	Communication error ⁽²⁾	NOT (chip reset or comm. error) i.e. cold start ⁽³⁾	TSD2 ⁽⁴⁾	TSD1	V ₁ Fail	Vs fail ⁽⁵⁾ (OV/UV)	Fail safe ⁽⁶⁾	
SPI error (DI stuck)	1	0	1	0	0	0	0	1	A1
TSD1	1	0	1	0	1	0	0	0	A8
TSD2	1	0	1	1	1	0	0	1	B9
V ₁ fail	1	0	1	0	0	1	0	0	A4
Other device failure ⁽⁸⁾	1	0	1	0	0	0	0	0	A0

- The following status bits are reported in the global error flag:
 - Global status register: Bits 0 - 6
 - Status register 1: Bits 0 – 10
 - Status register 3: Bits 2, 3, 15
- Invalid CLOCK COUNT.
- Cleared with CLR command on SR3.
- Cleared with “READ and CLEAR” on SR3 (-> TSD1).
- Diagnosis bit only, Vs Fail is not a fail-safe event; cleared by read&clear. Bit is automatically cleared at (Vs > VsUV) and (Vs < VsOV) if Vlock_out_en = 0.
- Cleared with a valid WD trigger (WD fail) or by clearing the corresponding status register related to failure.
- Slow Vs ramp-up (Vs undervoltage is filtered with 64 μs after Power-on reset).
- The global error flag is raised due to a failure condition which is not reported in the global status register. The Failure is reported in the status registers 1 – 3.

Status register 1

Table 97. Status register 1: command and data bytes

Command byte								1 st data byte	2 nd data byte
Read/write		Address						Bit <15:8>	Bit<7:0>
x	x	0	1	0	0	0	1	Data, 8bit	Data, 8 bit

Table 98. Status register 1, data bytes

	1 st data byte <15:8>									2 nd data byte <7:0>						
Function	OL HS	OL OUT4	OL OUT3	OL OUT2	OL OUT1	UV	V ₂ fail	V ₂ short	OV	OC HS	OC Out4	OC Out3	OC OUT2	OC Out1	OC Rel2	OC Rel1
Group	Diagnosis 1									Diagnosis 2						

Table 99. Status register 1, bits

Bit	Name	Comment	Information storage						
15	OL_HS	Open-load event occurred since last read out	Bit is latched until a "read and clear" access						
14	OL_OUT4								
13	OL_OUT3								
12	OL_OUT2								
11	OL_OUT1								
10	UV	Under voltage event on V_S occurred since last read out	<table border="1"> <thead> <tr> <th>VLOCKOUTEN (CR4)</th> <th>Information storage</th> </tr> </thead> <tbody> <tr> <td>0</td> <td>automatically reset when UV condition disappears</td> </tr> <tr> <td>1</td> <td>Bit is latched until a "read and clear" access</td> </tr> </tbody> </table>	VLOCKOUTEN (CR4)	Information storage	0	automatically reset when UV condition disappears	1	Bit is latched until a "read and clear" access
VLOCKOUTEN (CR4)	Information storage								
0	automatically reset when UV condition disappears								
1	Bit is latched until a "read and clear" access								
9	V_2 _fail	V_2 fail ($V_2 < 2\text{ V}$ for $t > 2\ \mu\text{s}$) event occurred since last readout	Bit is latched until a "Read and clear" access						
8	V_2 _short	V_2 short ($V_2 < 2\text{ V}$ for $t > 4\text{ms}$ during start up) event occurred since last readout	Bit is latched until a "Read and clear" access						
7	OV	Over voltage event on V_S occurred since last read out	<table border="1"> <thead> <tr> <th>VLOCKOUTEN (CR4)</th> <th>Information storage</th> </tr> </thead> <tbody> <tr> <td>0</td> <td>automatically reset when OV condition disappears</td> </tr> <tr> <td>1</td> <td>Bit is latched until a "read and clear" access</td> </tr> </tbody> </table>	VLOCKOUTEN (CR4)	Information storage	0	automatically reset when OV condition disappears	1	Bit is latched until a "read and clear" access
VLOCKOUTEN (CR4)	Information storage								
0	automatically reset when OV condition disappears								
1	Bit is latched until a "read and clear" access								
6	OC_HS	Over current event occurred since last read out	Bit is latched until a "read and clear" access						
5	OC_OUT4								
4	OC_OUT3								
3	OC_OUT2								
2	OC_OUT1								
1	OC_REL2								
0	OC_REL1								

Status register 2

Table 100. Status register 2: command and data bytes

Command byte								1 st data byte	2 nd data byte
Read/write		Address						Bit <15:8>	Bit<7:0>
x	x	0	1	0	0	1	0	Data, 8bit	Data, 8 bit

Table 101. Status register 2, data bytes

Function	1 st data byte <15:8>								2 nd data byte <7:0>							
	WU3 state	WU2 state	WU1 state	WU3 wake	WU2 wake	WU1 wake	Wake CAN	Wake LIN	Wake Timer int	LIN perm. dom.	LIN TxD perm dom.	LIN perm. rec.	CAN RxD perm rec.	CAN perm. rec.	CAN perm. dom.	CAN TxD perm dom.
Group	Diagnosis 3								Diagnosis 4							

Table 102. Status register 2, bits

Bit	Name	Comment	Information storage
15	WU3_state	State of WUx input;	"Live bits" not clearable
14	WU2_state		
13	WU1_state		
12	WU3_wake	Shows wake up source ('1' = wake-up)	Bits are latched until a "Read and clear" access
11	WU2_wake		
10	WU1_wake		
9	WAKE_CAN		
8	WAKE_LIN		
7	Wake_TIMER_int		
6	LIN_perm_DOM	LIN bus is dominant for t > 12 ms	
5	LIN_TxD_perm_DOM	TxDL pin is dominant for t > 12 ms; Transmitter is disabled	
4	LIN_perm_REC	LIN bus does not follow TxDL within 40 μs; Transmitter is disabled	
3	CAN_RxD_perm_rec	RxDC has not followed TxDC for 4 times; Transmitter is disabled	
2	CAN_perm_REC	CAN has not followed TxDC for 4 times; Transmitter is disabled	
1	CAN_perm_DOM	CAN bus is dominant for t > 700 μs	
0	CAN_TxD_perm_DOM	TxDC pin is dominant for t > 700 μs; Transmitter is disabled	

Status register 3

Table 103. Status register 3: command and data bytes

Command byte								1 st data byte	2 nd data byte
Read/write		Address						Bit <15:8>	Bit<7:0>
x	x	0	1	0	0	1	1	Data, 8bit	Data, 8 bit

Table 104. Status register 3, data bytes

	1 st data byte <15:8>								2 nd data byte <7:0>							
Function	TSD1	TW	Device state_2	Device state_1	V ₁ fail	V ₁ restart_2	V ₁ restart_1	V ₁ restart_0	WD fail_3	WD fail_2	WD fail_1	WD fail_0	Forced sleep WD	Forced sleep TSD2 SHTV1	WD timer state_1	WD timer state_0
Group	Diagnosis 5								Diagnosis 6							

Table 105. Status register 3, bits

Bit	Name	Comment	Information storage		
15	TSD1	Thermal warning / shutdown1 occurred since last readout	Bit is latched until a "read and clear access"		
14	TW				
13	Device_state	State from which the device woke up	Bit is latched until a "read and clear access" after a "read and clear access", the device state is updated after a wake up, device state is 01: V ₁ standby or 10: V _{BAT} standby		
12		Device state_2		Device state_1	State from which the device woke up
		0		0	Active
		0		1	V ₁ standby
		1		0	V _{BAT} standby
		1		1	Flash
11	V ₁ _fail	V ₁ fail (V ₁ < 2 V for t > 2 μs) event occurred since last read out	Bit is latched until a "read and clear access"		
10	V ₁ _restart_2	Number of TSD2 events which caused a restart of V ₁ regulator (7 TSD2 events forces the device into V _{BAT} standby)	Bits are not clearable; is cleared automatically if no additional TSD2 event occurs within 1 min.		
9	V ₁ _restart_1				
8	V ₁ _restart_0				
7	WD_fail_3	Number of missing watchdog triggers (15 missing watchdog trigger forces the device into V _{BAT} standby)	Bits are not clearable; is cleared with a proper Watchdog trigger		
6	WD_fail_2				
5	WD_fail_1				
4	WD_fail_0				

Table 105. Status register 3, bits (continued)

Bit	Name	Comment	Information storage			
3	Forced_sleep_WD	Device was forced to V _{BAT} standby mode because of multiple watchdog errors	Bits are latched until a read and clear access			
2	Forced_sleep_TSD 2_SHTV ₁	Device was forced to V _{BAT} standby or multiple thermal shutdown events or a short on V ₁ during startup.				
1	WD_timer_state_1	Status of watchdog counter of selected watchdog timing	Bits are not clearable			
0	WD_timer_state_0					
				WD_timer_state_1	WD_timer_state_0	Counter
				0	0	0 – 33%
				0	1	33 – 66%
		1	1	66 – 100%		

7 Package and packing information

7.1 ECOPACK®

In order to meet environmental requirements, ST offers these devices in different grades of ECOPACK® packages, depending on their level of environmental compliance. ECOPACK® specifications, grade definitions and product status are available at: www.st.com.

ECOPACK® is an ST trademark.

7.2 PowerSSO-36 package information

Figure 41. PowerSSO-36 package dimensions

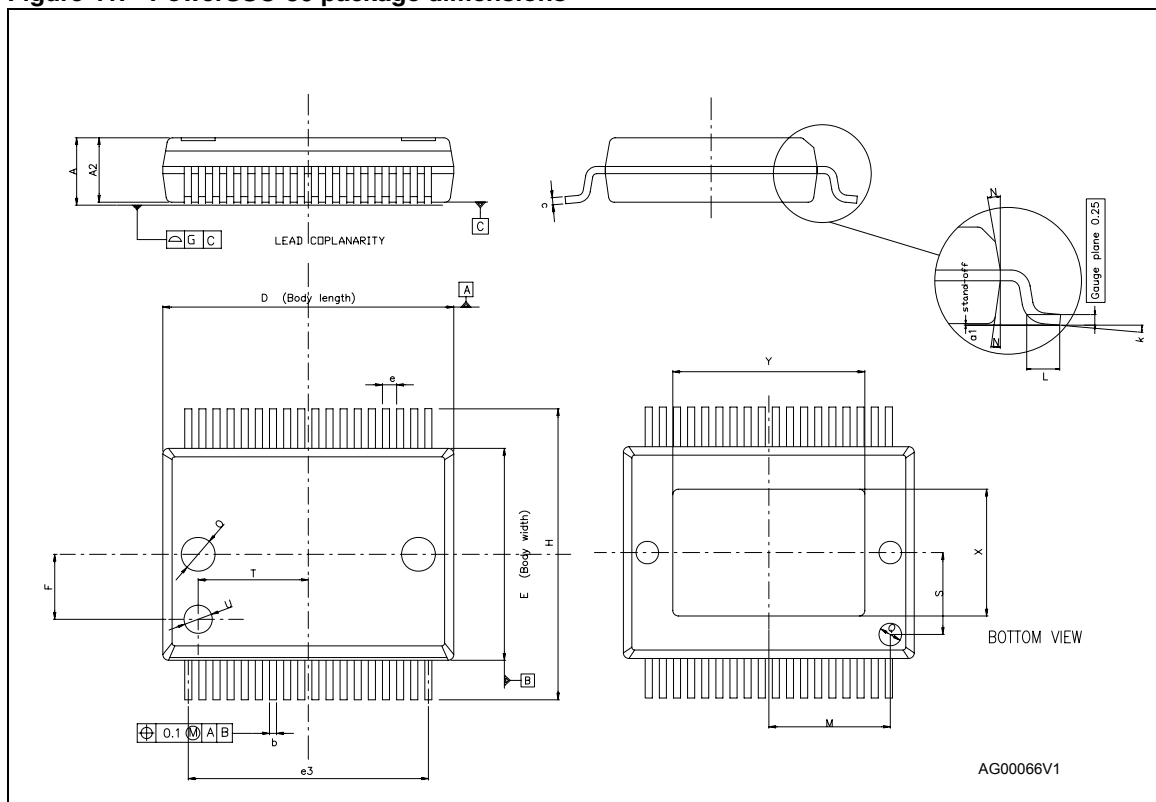

Table 106. PowerSSO-36 mechanical data

Symbol	Millimeters		
	Min.	Typ.	Max.
A	-	-	2.45
A2	2.15	-	2.35
a1	0	-	0.1
b	0.18	-	0.36
c	0.23	-	0.32
D	10.10	-	10.50
E	7.4	-	7.6
e	-	0.5	-
e3	-	8.5	-
F	-	2.3	-
G	-	-	0.1
G1	-	-	0.06
H	10.1	-	10.5
h	-	-	0.4
k	0°	-	8°
L	0.55	-	0.85
M	-	4.3	-
N	-	-	10 deg
O	-	1.2	-
Q	-	0.8	-
S	-	2.9	-
T	-	3.65	-
U	-	1.0	-
X	4.1	-	4.7
Y	6.5	-	7.1

8 Revision history

Table 107. Document revision history

Date	Revision	Change
24-Jan-2011	1	Initial release.
23-Feb-2011	2	<i>Table 11: Temperature warning and thermal shutdown:</i> – T _{SD2 OFF} : updated minimum and typical values
01-Jun-2011	3	Updated following figures: – <i>Figure 3: Voltage source with external PNP</i> – <i>Figure 5: Voltage source with external NPN</i>

Please Read Carefully:

Information in this document is provided solely in connection with ST products. STMicroelectronics NV and its subsidiaries ("ST") reserve the right to make changes, corrections, modifications or improvements, to this document, and the products and services described herein at any time, without notice.

All ST products are sold pursuant to ST's terms and conditions of sale.

Purchasers are solely responsible for the choice, selection and use of the ST products and services described herein, and ST assumes no liability whatsoever relating to the choice, selection or use of the ST products and services described herein.

No license, express or implied, by estoppel or otherwise, to any intellectual property rights is granted under this document. If any part of this document refers to any third party products or services it shall not be deemed a license grant by ST for the use of such third party products or services, or any intellectual property contained therein or considered as a warranty covering the use in any manner whatsoever of such third party products or services or any intellectual property contained therein.

UNLESS OTHERWISE SET FORTH IN ST'S TERMS AND CONDITIONS OF SALE ST DISCLAIMS ANY EXPRESS OR IMPLIED WARRANTY WITH RESPECT TO THE USE AND/OR SALE OF ST PRODUCTS INCLUDING WITHOUT LIMITATION IMPLIED WARRANTIES OF MERCHANTABILITY, FITNESS FOR A PARTICULAR PURPOSE (AND THEIR EQUIVALENTS UNDER THE LAWS OF ANY JURISDICTION), OR INFRINGEMENT OF ANY PATENT, COPYRIGHT OR OTHER INTELLECTUAL PROPERTY RIGHT.

UNLESS EXPRESSLY APPROVED IN WRITING BY AN AUTHORIZED ST REPRESENTATIVE, ST PRODUCTS ARE NOT RECOMMENDED, AUTHORIZED OR WARRANTED FOR USE IN MILITARY, AIR CRAFT, SPACE, LIFE SAVING, OR LIFE SUSTAINING APPLICATIONS, NOR IN PRODUCTS OR SYSTEMS WHERE FAILURE OR MALFUNCTION MAY RESULT IN PERSONAL INJURY, DEATH, OR SEVERE PROPERTY OR ENVIRONMENTAL DAMAGE. ST PRODUCTS WHICH ARE NOT SPECIFIED AS "AUTOMOTIVE GRADE" MAY ONLY BE USED IN AUTOMOTIVE APPLICATIONS AT USER'S OWN RISK.

Resale of ST products with provisions different from the statements and/or technical features set forth in this document shall immediately void any warranty granted by ST for the ST product or service described herein and shall not create or extend in any manner whatsoever, any liability of ST.

ST and the ST logo are trademarks or registered trademarks of ST in various countries.

Information in this document supersedes and replaces all information previously supplied.

The ST logo is a registered trademark of STMicroelectronics. All other names are the property of their respective owners.

© 2011 STMicroelectronics - All rights reserved

STMicroelectronics group of companies

Australia - Belgium - Brazil - Canada - China - Czech Republic - Finland - France - Germany - Hong Kong - India - Israel - Italy - Japan - Malaysia - Malta - Morocco - Philippines - Singapore - Spain - Sweden - Switzerland - United Kingdom - United States of America

www.st.com