

# $\mu$ A734 Precision Voltage Comparator

Linear Products

### Description

The  $\mu$ A734 is a Precision Voltage Comparator constructed on a single silicon chip using the Fairchild Planar epitaxial process. It is specifically designed for high accuracy level sensing and measuring applications. The  $\mu$ A734 is extremely useful for analog-to-digital converters with 12-bit accuracies and one mega-bit conversion rates. Maximum resolution is obtained by high gain, low input offset current, and low input offset voltage. Its superior temperature stability can be improved by offset nulling which further reduces offset voltage drift. Balanced or unbalanced supply operation and standard TTL logic compatibility enhance the  $\mu$ A734 versatility.

- **CONSTANT INPUT IMPEDANCE OVER DIFFERENTIAL INPUT RANGE**
- **HIGH INPUT IMPEDANCE—55 M $\Omega$**
- **LOW DRIFT—3.5  $\mu$ V/ $^{\circ}$ C**
- **HIGH GAIN—60 k**
- **BALANCED OFFSET NULL CAPABILITY**
- **WIDE SUPPLY VOLTAGE RANGE— $\pm 5$  V to  $\pm 18$  V**
- **TTL COMPATIBLE**

<b>Absolute Maximum Ratings</b>	$T_A = 25^{\circ}\text{C}$ unless specified otherwise
Supply Voltage	$\pm 18$ V
Peak Output Current	10 mA
Differential Input Voltage	$\pm 10$ V
Input Voltage Range (Note 1)	$\pm 13$ V
Voltage Between Offset Null and V-	$\pm 0.5$ V
Internal Power Dissipation (Note 2)	
Metal Package	500 mW
Ceramic DIP	670 mW
Operating Temperature Range	
Military ( $\mu$ A734)	$-55^{\circ}\text{C}$ to $+125^{\circ}\text{C}$
Commercial ( $\mu$ A734C)	$0^{\circ}\text{C}$ to $+70^{\circ}\text{C}$
Storage Temperature Range	
Metal Can, DIP	$-65^{\circ}\text{C}$ to $+150^{\circ}\text{C}$
Pin Temperature (Soldering, 60 s Max)	$300^{\circ}\text{C}$

### Notes

1. Rating applies for  $\pm 15$  V supplies. For other supply voltages the rating is within 2 V of either supply.
2. Rating applies to ambient temperatures up to  $70^{\circ}\text{C}$ . Above  $70^{\circ}\text{C}$  ambient derate linearly at 6.3 mW/ $^{\circ}\text{C}$  for metal package, 8.3 mW/ $^{\circ}\text{C}$  for DIP.

### Connection Diagram 10-Pin Metal Package

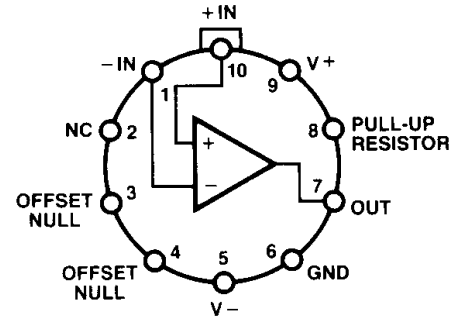

(Top View)

### Order Information

Type	Package	Code	Part No.
$\mu$ A734	Metal	5N	$\mu$ A734HM
$\mu$ A734C	Metal	5N	$\mu$ A734HC

### Connection Diagram 14-Pin DIP

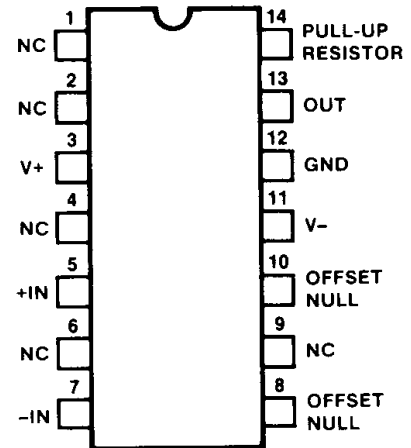

(Top View)

### Order Information

Type	Package	Code	Part No.
$\mu$ A734	Ceramic DIP	6A	$\mu$ A734DM
$\mu$ A734C	Ceramic DIP	6A	$\mu$ A734DC

Equivalent Circuit

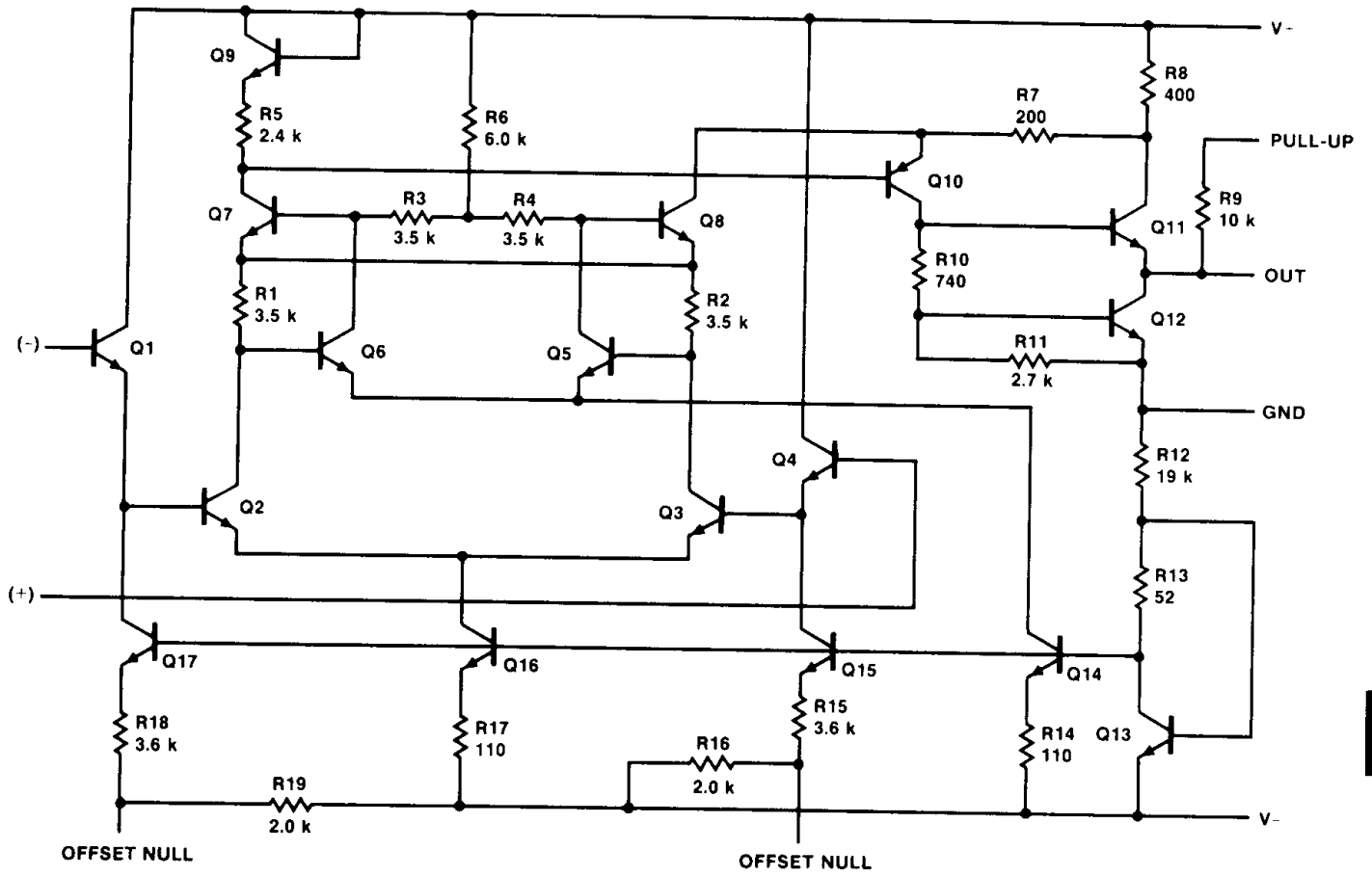

5

**μA734C Electrical Characteristics**  $T_A = 25^\circ\text{C}$ , Pin 8 tied to +15 V, unless otherwise specified,  $V_{\pm} = \pm 15\text{V}$ .  
(Note 3)

Characteristic	Condition	Min	Typ	Max	Unit
Input Offset Voltage	$R_S \leq 50\text{ k}\Omega$		1.1	5.0	mV
Input Offset Current			3.5	25	nA
Input Bias Current			30	100	nA
Input Resistance		7.0	55		MΩ
Input Capacitance			3.0		pF
Offset Voltage Adjustment Range			8.5		mV
Large Signal Voltage Gain	$R_L = 1.5\text{ k}\Omega$ to +5.0 V	35 k	60 k		V/V
Positive Supply Current Output LOW			4.0	5.0	mA
Negative Supply Current Output LOW			1.5	2.0	mA
Power Consumption—Output LOW			82	105	mW
Transient Response	$R_L = 1.5\text{ k}\Omega$ to +5.0 V 5 mV Overdrive, 100 mV Pulse		200		ns

The following specifications apply for  $0^\circ\text{C} \leq T_A \leq +70^\circ\text{C}$

Input Offset Voltage	$R_S \leq 50\text{ k}\Omega$		1.2	7.5	mV
Input Offset Current			4.0	45	nA
Average Input Offset Voltage Drift Without External Trim	$R_S \leq 50\text{ }\Omega$		3.5	20	$\mu\text{V}/^\circ\text{C}$
Average Input Offset Current Drift	$T_A = +25^\circ\text{C}$ to $+70^\circ\text{C}$		0.02	0.3	nA/ $^\circ\text{C}$
	$T_A = +25^\circ\text{C}$ to $0^\circ\text{C}$		0.05	0.75	nA/ $^\circ\text{C}$
Input Bias Current				150	nA
Large Signal Voltage Gain	$R_L = 1.5\text{ k}\Omega$ to +5.0 V	25 k			V/V
Input Common Mode Voltage Range		$\pm 10$			V
Differential Input Voltage Range		$\pm 10$			V
Common Mode Rejection Ratio	$R_S \leq 50\text{ k}\Omega$	70	100		dB
Supply Voltage Rejection Ratio $V_S = \pm 5\text{ V}$ to $\pm 18\text{ V}$	$R_S \leq 50\text{ k}\Omega$		6.0	100	$\mu\text{V}/\text{V}$
Output HIGH Voltage	$I_{\text{OUT}} = 0.080\text{ mA}$	7.0			V
	$I_{\text{OUT}} = 0.080\text{ mA}$ , $V_8 = +5.0\text{ V}$	2.4		5.0	V
Output LOW Voltage	$I_{\text{SINK}} = 3.2\text{ mA}$			0.4	V
Positive Supply Current Output LOW				7.0	mA
Negative Supply Current Output LOW				2.5	mA
Power Dissipation—Output LOW				145	mW

**Note**

3. Pin numbers refer to metal package.

# μA734

**μA734 Electrical Characteristics**  $T_A = 25^\circ\text{C}$ , Pin 8 tied to +15 V, unless otherwise specified,  $V_{\pm} = \pm 15\text{ V}$ .  
(Note 3)

Characteristic	Condition	Min	Typ	Max	Unit
Input Offset Voltage	$R_S \leq 50\text{ k}\Omega$		0.9	3.0	mV
Input Offset Current			1.5	10	nA
Input Bias Current			28	50	nA
Input Resistance		20	60		MΩ
Input Capacitance			3.0		pF
Offset Voltage Adjustment Range			8.5		mV
Large Signal Voltage Gain	$R_L = 1.5\text{ k}\Omega$ to +5.0 V	35 k	70 k		V/V
Positive Supply Current Output LOW			4.0	5.0	mA
Negative Supply Current Output LOW			1.5	2.0	mA
Power Consumption—Output LOW			82	105	mW
Transient Response	$R_L = 1.5\text{ k}\Omega$ to +5.0 V 5 mV Overdrive, 100 mV Pulse		200		ns

The following specifications apply for  $-55^\circ\text{C} \leq T_A \leq +125^\circ\text{C}$

Input Offset Voltage	$R_S \leq 50\text{ k}\Omega$		1.1	4.0	mV
Input Offset Current			3.0	20	nA
Average Input Offset Voltage Drift Without External Trim	$R_S \leq 50\text{ k}\Omega$		2.5	15	$\mu\text{V}/^\circ\text{C}$
Average Input Offset Current Drift	$T_A = +25^\circ\text{C}$ to $+125^\circ\text{C}$ $T_A = +25^\circ\text{C}$ to $-55^\circ\text{C}$		0.01 0.05	0.1 0.4	nA/ $^\circ\text{C}$ nA/ $^\circ\text{C}$
Input Bias Current				150	nA
Large Signal Voltage Gain	$R_L = 1.5\text{ k}\Omega$ to +5.0 V	25 k			V/V
Input Common Mode Voltage Range		$\pm 10$			V
Differential Input Voltage Range		$\pm 10$			V
Common Mode Rejection Ratio	$R_S \leq 50\text{ k}\Omega$	70	100		dB
Supply Voltage Rejection Ratio $V_S = \pm 5\text{ V}$ to $\pm 18\text{ V}$	$R_S \leq 50\text{ k}\Omega$		5.0	100	$\mu\text{V}/\text{V}$
Output HIGH Voltage	$I_{\text{OUT}} = 0.080\text{ mA}$ $I_{\text{OUT}} = 0.080\text{ mA}$ , $V_8 = +5.0\text{ V}$	7.0 2.4		5.0	V V
Output LOW Voltage	$I_{\text{SINK}} = 3.2\text{ mA}$			0.4	V
Positive Supply Current Output LOW				7.0	mA
Negative Supply Current Output LOW				2.5	mA
Power Dissipation—Output LOW				145	mW

**Note**

3. Pin numbers refer to metal package.

Typical Performance Curves For  $\mu A734$  and  $\mu A734C$

Transfer Characteristics

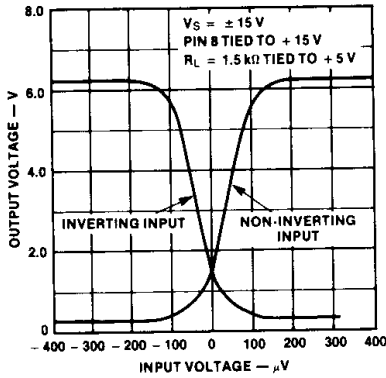

Un-Null'd Input Offset Voltage vs. Ambient Temperature

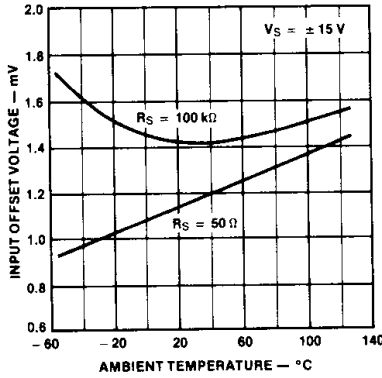

Input Offset Voltage Change vs. Ambient Temperature Null'd to Zero at 25  $^{\circ}C$

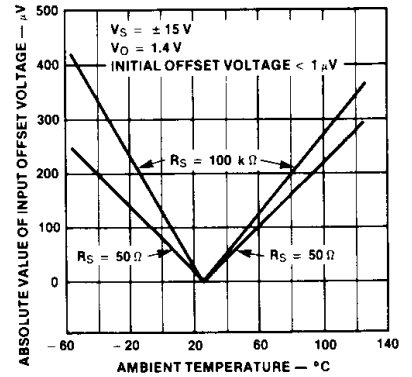

Input Bias Current vs. Ambient Temperature

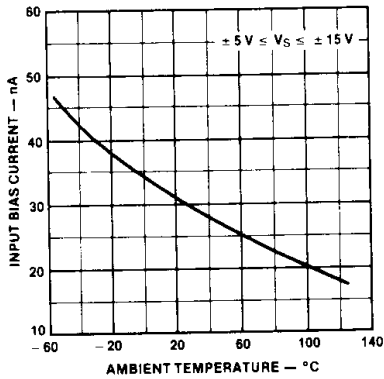

Input Bias Current vs. Differential Input Voltage

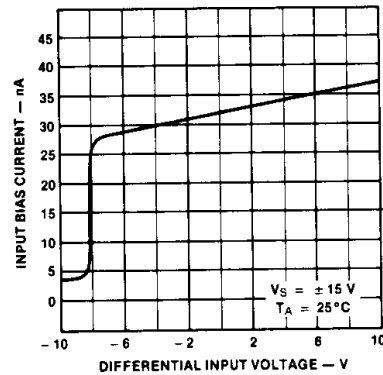

Input Offset Current vs. Ambient Temperature

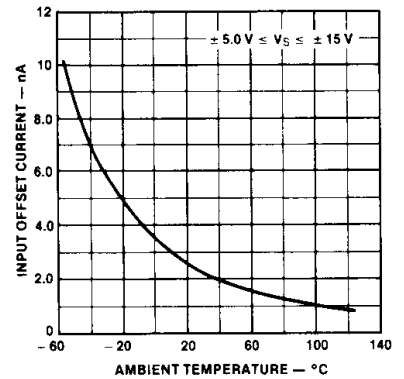

Output High Voltage vs. Supply Voltage and Ambient Temperature

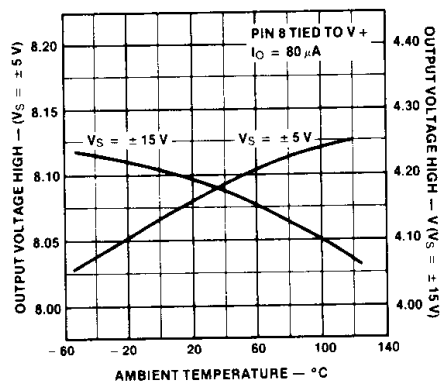

Output Low Voltage vs. Supply Voltage and Ambient Temperature

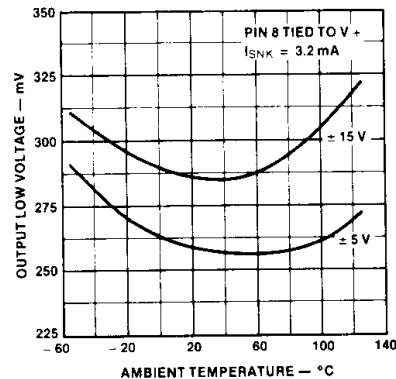

Output Voltage Low vs. Sink Current

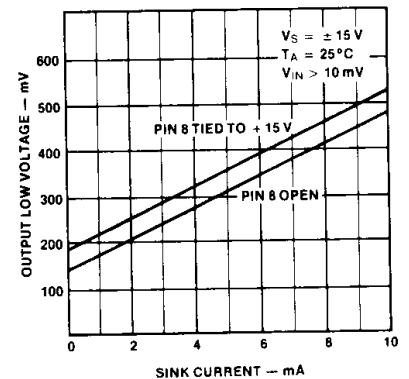

**Typical Performance Curves for μA734 and μA734C (Cont.)**

**Voltage Gain vs. Ambient Temperature**

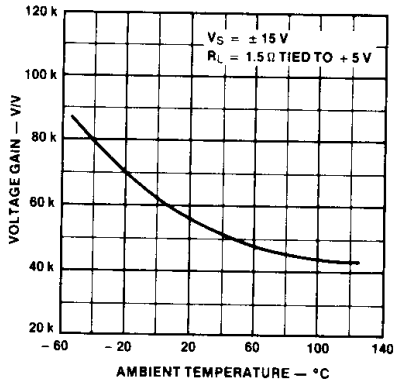

**Voltage Gain vs. Supply Voltage**

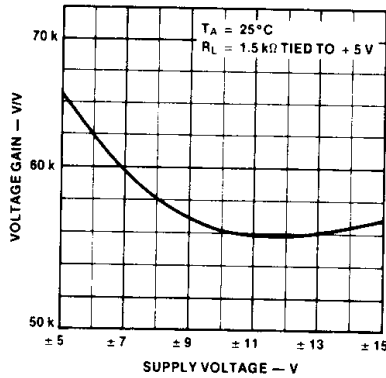

**Positive and Negative Supply Currents vs. Ambient Temperature**

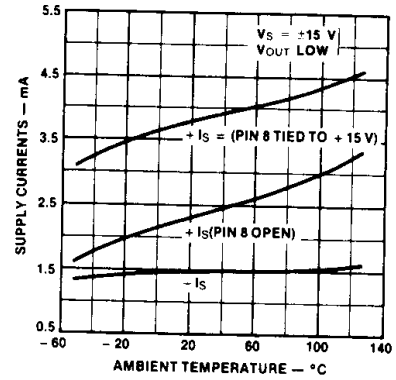

**Response Time For Various Input Overdrives**

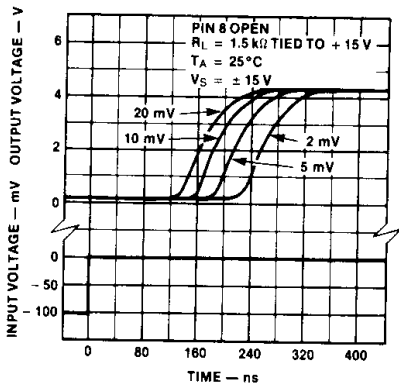

**Response Time For Various Input Overdrives**

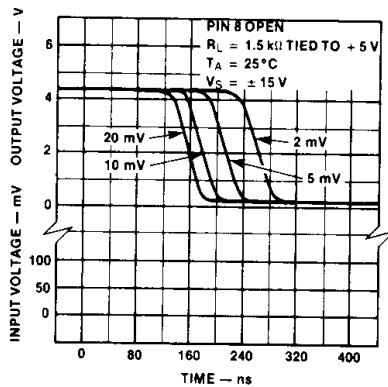

**Input Offset Voltage Drift vs. Time**

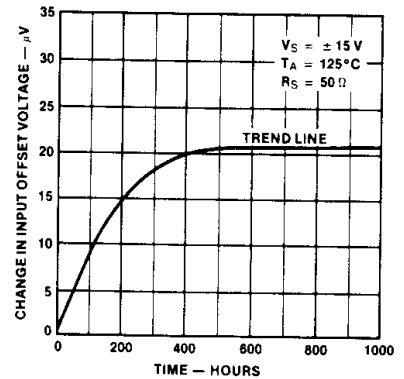

5

**Response Time For Various Input Overdrives**

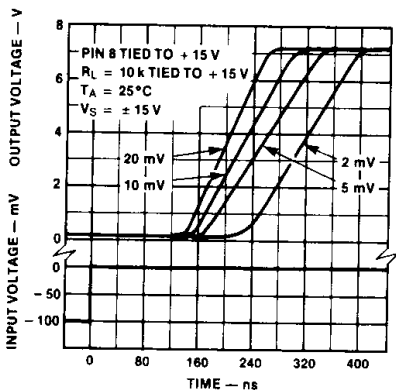

**Response Time For Various Input Overdrives**

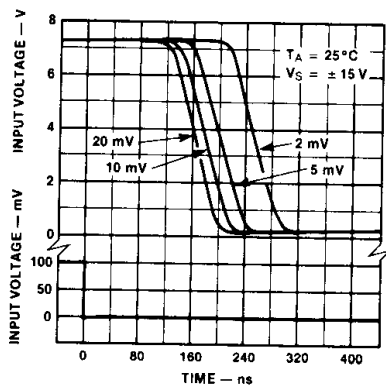

**Stabilization Time of Input Offset Voltage From Power Turn-On**

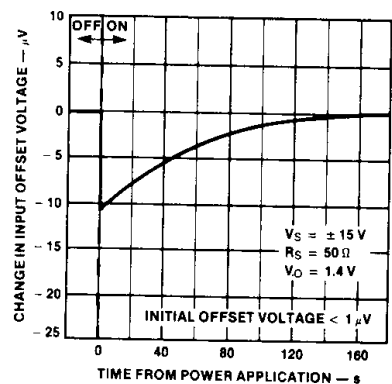

Typical Performance Curves for  $\mu A734$  and  $\mu A734C$  (Cont.)

Response Time For Various Input Overdrives

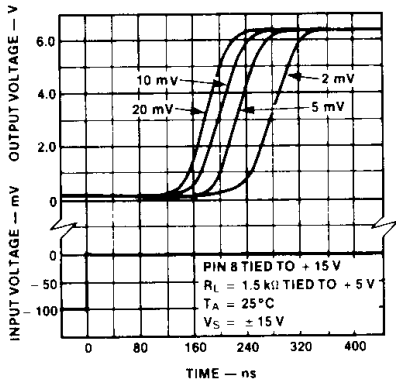

Response Time For Various Input Overdrives

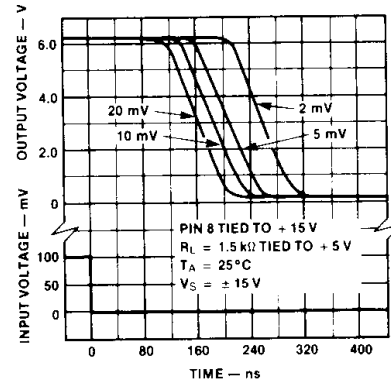

Thermal Response of Input Offset Voltage To Step Change of Case Temperature

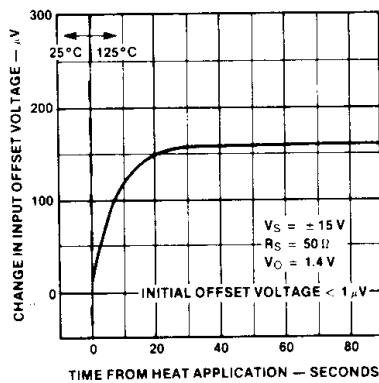

Common Mode Rejection Ratio vs. Ambient Temperature

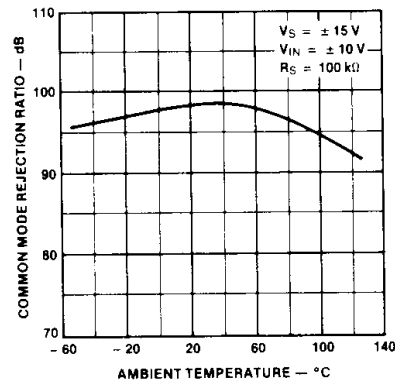

Test Circuits

Offset Null Circuit

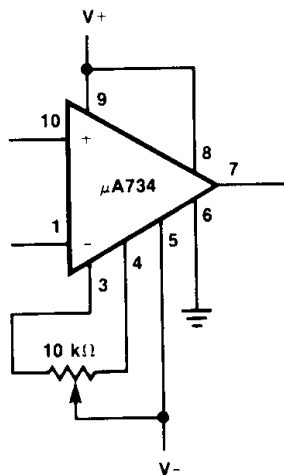

AC Test Circuit

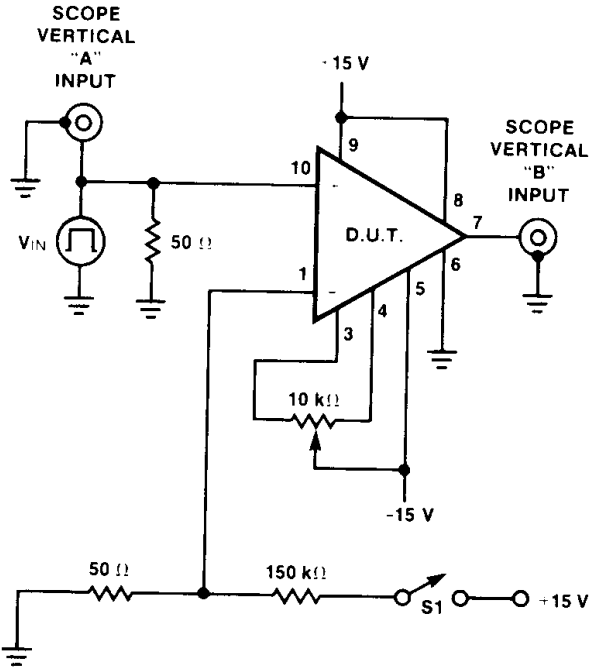

Typical Applications (Cont.)

Level Detector With Hysteresis

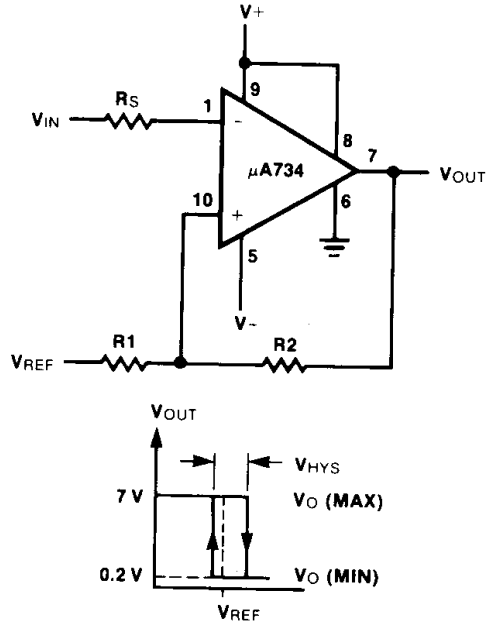

$$R_S = \frac{R_1 R_2}{R_1 + R_2} \text{ FOR MINIMUM OFFSET}$$

$$V_{HYS} = \frac{R_1 [V_{O \text{ MAX}} - V_{O \text{ MIN}}]}{R_1 + R_2}$$

5

Typical Applications

Strobe Circuitry

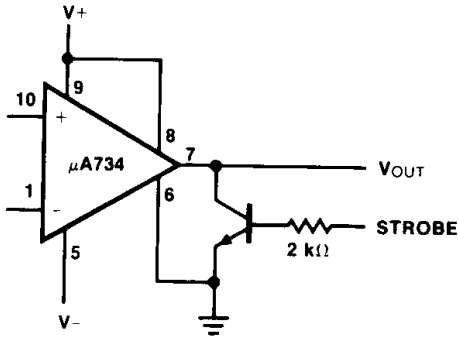

High Power Output Circuits

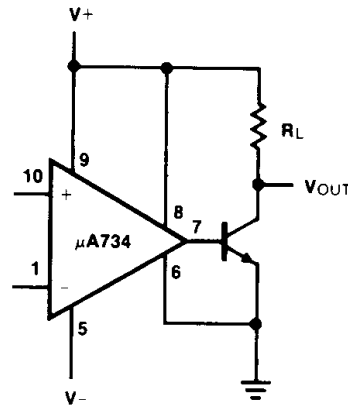

Alternate Strobe Circuitry

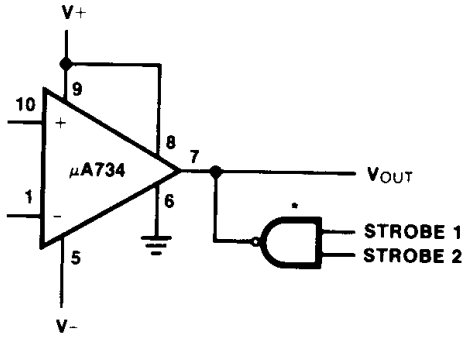

\* 1/2 9944



Typical Applications (Cont.)

Free Running Oscillator

Precision Dual Limit Go No Go Tester

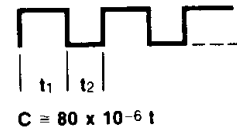
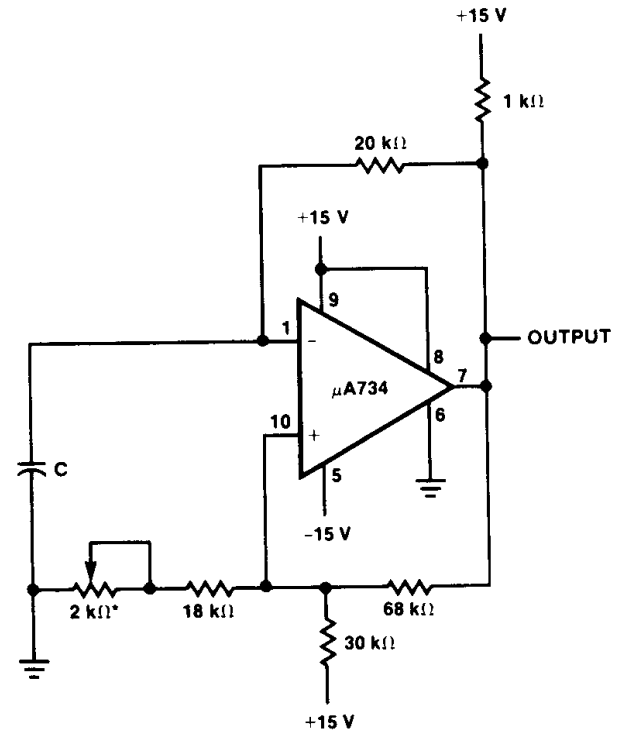
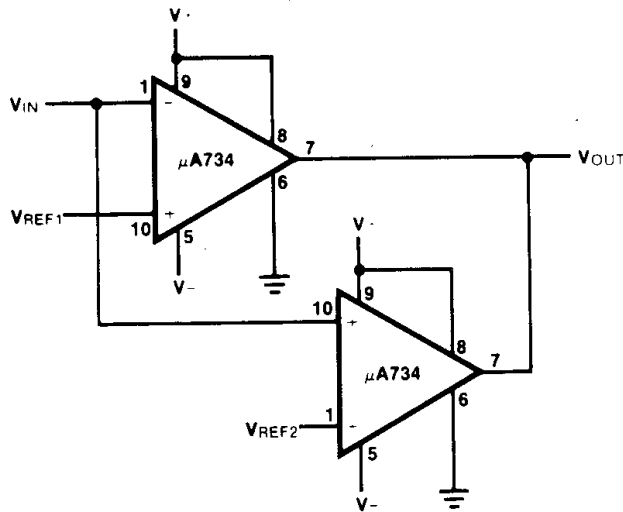

\*Adjusts  $\frac{T_1}{T_2}$

Voltage Controlled Oscillator

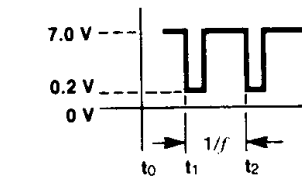
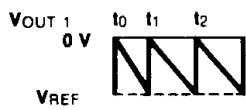
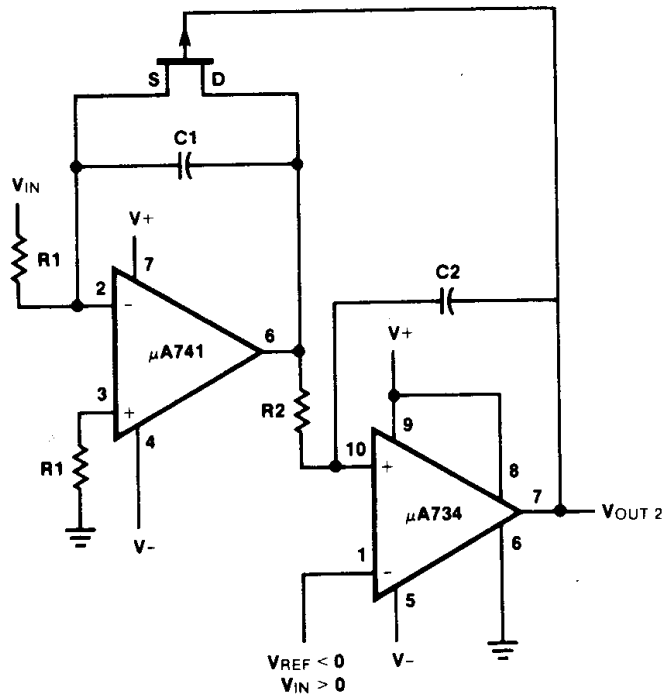

$$\frac{V_{IN}}{|V_{REF}| R_1 C_1}$$

$$R_2 C_2 > \frac{|V_{REF}| C_1}{I_{DSS}}$$

Typical Applications (Cont.)

Frequency Divider and Staircase Generator

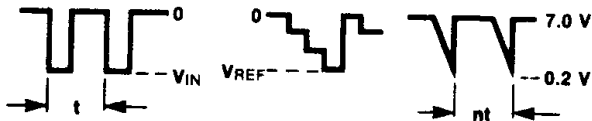
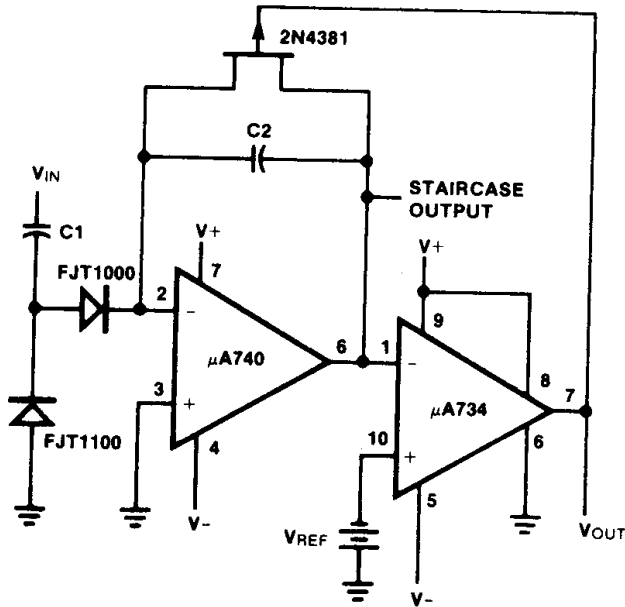

$$|V_{REF}| = 2V_D + N \left[ 3.5T + 2V_D - \frac{C_1 V_{IN}}{C_2} \right]$$

T in Seconds  
 $V_D$  for FJT 1000  $\approx$  0.31 V

Pulse Width Discriminator

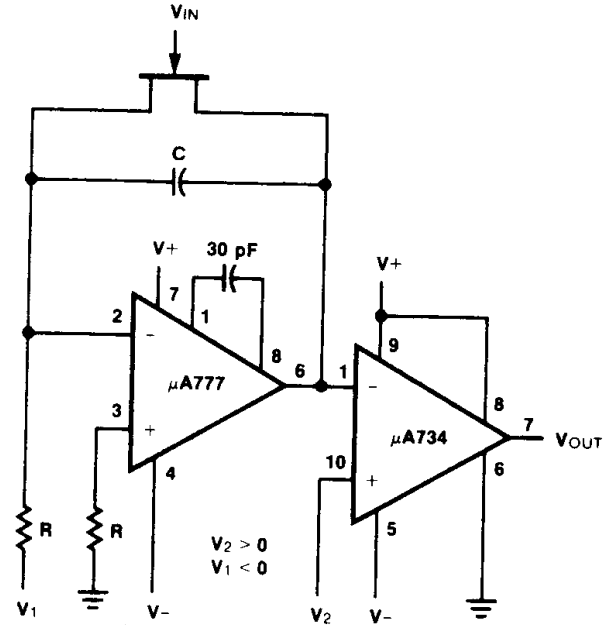

V<sub>OUT</sub> Pulse Appears

$$\text{Whenever } T > \frac{RCV_2}{V_1}$$

Phase Meter

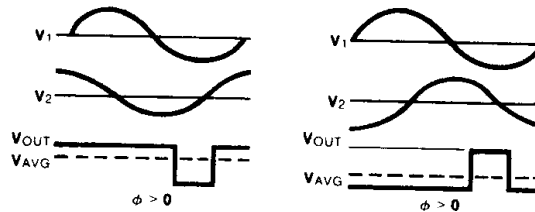
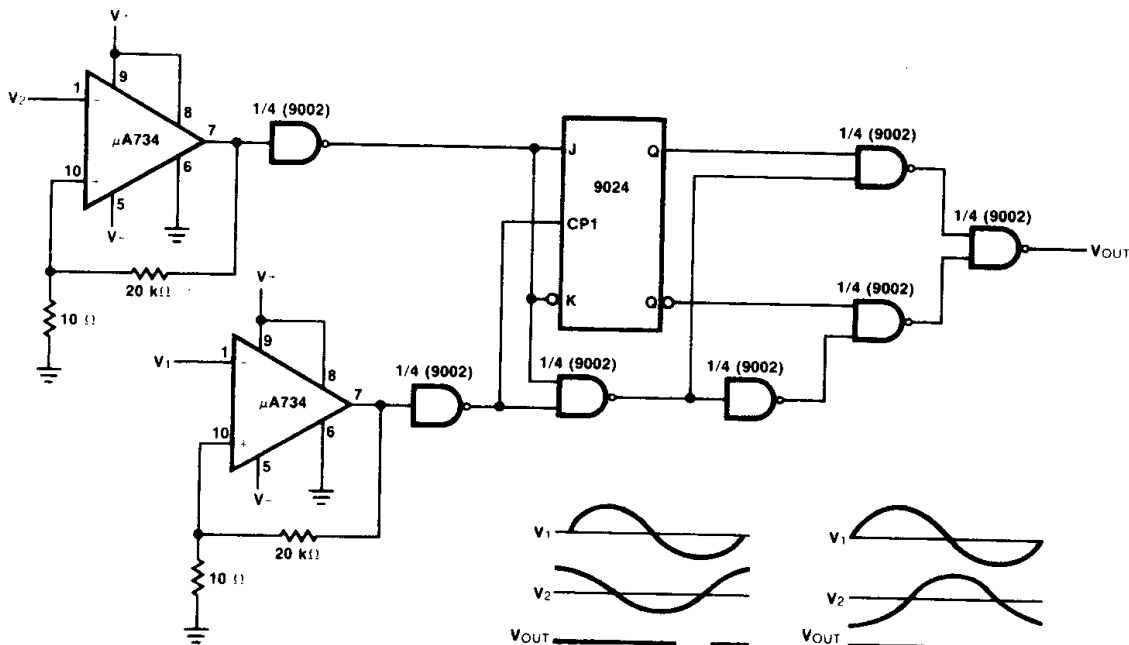

$$\phi = \frac{2\pi V_{AVG}}{V_{OUT, PEAK}} - \pi$$

5