

μA7391

DC MOTOR SPEED CONTROL CIRCUIT

FAIRCHILD LINEAR INTEGRATED CIRCUITS

GENERAL DESCRIPTION – The μA7391 is designed for precision, closed-loop, motor speed control systems. It regulates the speed of capstan drive motors in automotive and portable tape players and is useful in a variety of industrial control applications, *e.g.*, floppy disc drive systems, data cartridge drive systems. The device is constructed using the Fairchild Planar* epitaxial process.

The μA7391 compares actual motor speed to an externally presettable reference voltage. The motor speed is determined by frequency to voltage conversion of the input signal provided by tachometer generator. The result of the comparison controls the duty cycle of the pulse width modulated switching motor drive output stage to close the system's negative feedback loop.

Thermal and over-voltage shutdown are included for self-protection, and a "stall-timer" feature allows the motor to be protected from burn-out during extended mechanical jams.

- **PRECISION PERFORMANCE – FREQUENCY-TO-VOLTAGE CONVERSION STABILITY TYPICALLY 0.1% FOR V+ FROM 10 V TO 16 V; 0.3% FOR CASE TEMPERATURE FROM -40°C TO +85°C**
- **HIGH CURRENT PERFORMANCE – 3.5 A STARTING SURGE CURRENT AND 2 A RUNNING CURRENT TO A DC MOTOR**
- **WIDE RANGE TACHOMETER INPUT – 100 mVp-p TO 1.0 Vp-p**
- **LOW EXTERNAL PARTS COUNT**
- **THERMAL SHUTDOWN, OVER-VOLTAGE AND STALL PROTECTION**
- **INTERNAL REGULATOR**
- **WIDE SUPPLY VOLTAGE RANGE – 6.3 V TO 16 V**

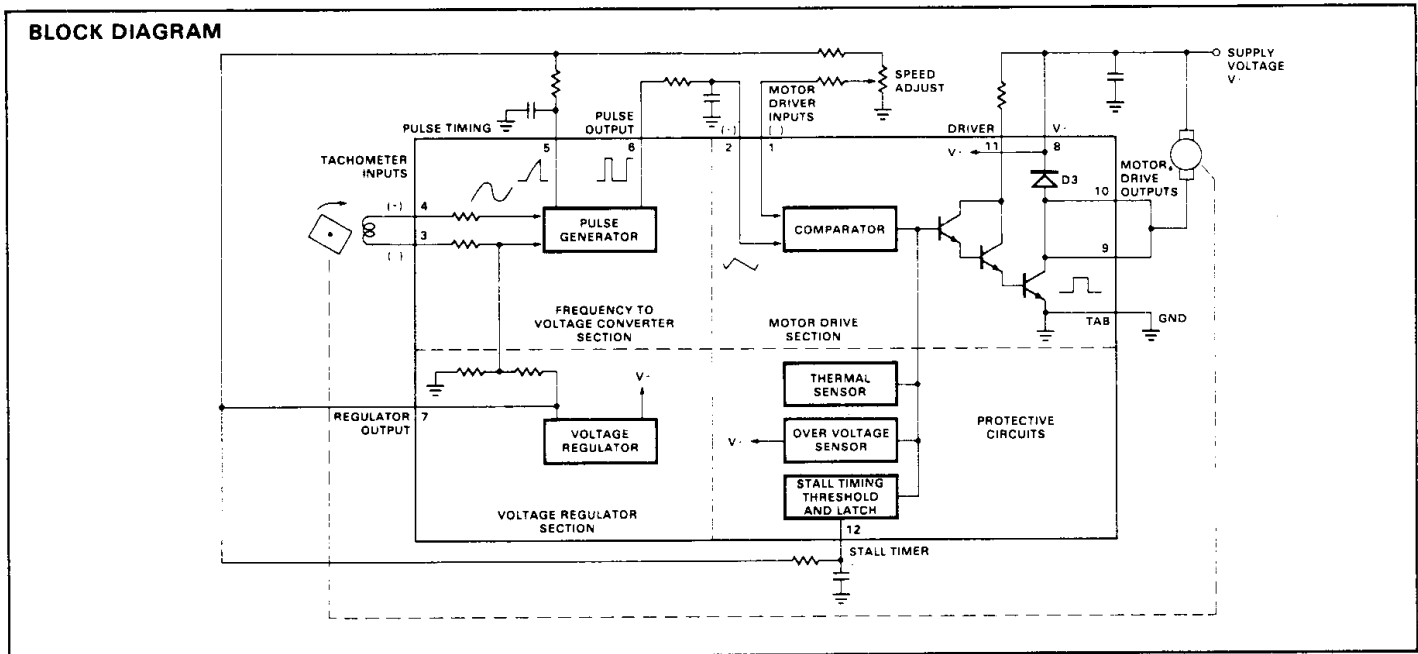
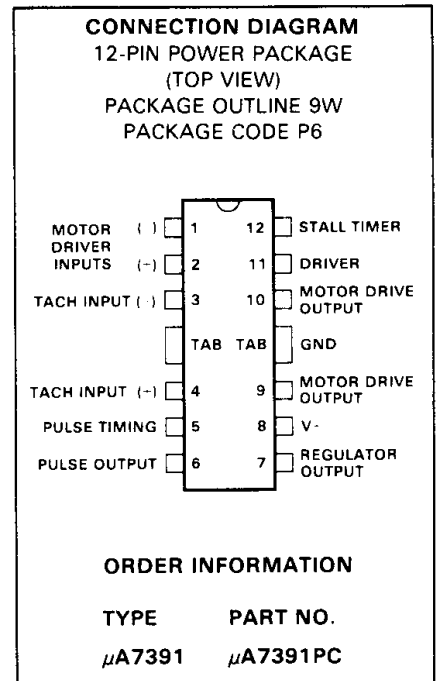

*Planar is a patented Fairchild process.

ABSOLUTE MAXIMUM RATINGS

Supply Voltage (V+), V _g	24 V
Regulator Output Current, I ₇	15 mA
Voltage Applied to Pin 5 (Tachometer Pulse Timing)	7 V
Voltage Applied Between Pins 3 and 4 (Tachometer Inputs)	±6 V
DC Voltage Applied to Pin 11 (Driver)	24 V
DC Voltage Applied to Pins 9 or 10 (Motor Drive Output)	V+
Continuous Current through pins 9 and 10: Motor Drive Output ON	2.0 A
Repetitive Surge Current through Pins 9 and 10: Motor Drive Output ON	3.5 A
Motor Drive Output OFF	2.0 A
Repetitive Surge Current through Pin 11	300 mA
Power Dissipation	Internally Limited
Storage Temperature Range	-55°C to +150°C
Operating Temperature Range	-40°C to +85°C
Lead Temperature (Soldering, 10 s)	260°C

THERMAL DATA

θ_{JC}	Thermal Resistance Junction to Case (tab) (max)	12°C/W
θ_{JA}	Thermal Resistance Junction to Ambient (max)	**70°C/W

**Obtained with tabs soldered to a printed circuit board having a minimum area of copper surrounding the tabs.

ELECTRICAL CHARACTERISTICS: V+ = 14.5 V, TA = 25°C, unless otherwise noted

VOLTAGE REGULATOR SECTION: (TEST CIRCUIT 1)

CHARACTERISTICS	CONDITIONS	MIN	TYP	MAX	UNITS
Power Supply Current	Excluding Current into Pins 9, 10 and 11		7.5	10	mA
Regulator Output Voltage		4.5	5.0	5.5	V
Regulator Output Line Regulation (ΔV_7)	V+ from 10 V to 16 V		6.0	20	mV
	V+ from 6.3 V to 16 V		12	50	mV
Regulator Output Load Regulation (ΔV_7)	I ₇ from 10 mA to 0		40		mV

ELECTRICAL CHARACTERISTICS: V+ = 14.5 V, TA = 25°C, unless otherwise noted

FREQUENCY TO VOLTAGE CONVERTER SECTION: (TEST CIRCUIT 2)

CHARACTERISTICS	CONDITIONS	MIN	TYP	MAX	UNITS
Tachometer (-) Input Bias Voltage			2.4		V
Tachometer (+) Input Bias Current	V ₄ = V ₃		1.0	10	μ A
Tachometer Input Positive Threshold	(V ₄ - V ₃)	10	25	50	mV _{pk}
Tachometer Input Hysteresis		20	50	100	mV _{p-p}
Pulse Timing ON Resistance	V ₅ = 1 V		300	500	Ω
Pulse Timing Switch Threshold		45	50	55	%V ₇
Output Pulse Rise Time			0.3		μ s
Output Pulse Fall Time			0.1		μ s
Pulse Output LOW Saturation (V ₆)			0.13	0.25	V
Pulse Output HIGH Saturation (V ₇ - V ₆)			0.12	0.2	V
Pulse Output HIGH Source Current	V ₆ = 1 V	-340	-260	-180	μ A
Frequency-to-Voltage Conversion Supply Voltage Stability (Note 1)	V _{FV} = 0.25 V ₇ (Note 2) V+ from 10 V to 16 V		0.1		%
Frequency-to-Voltage Conversion Temperature Stability (Note 3)	V _{FV} = 0.25 V ₇ (Note 2) T _A from -40°C to +85°C		0.3		%

7

ELECTRICAL CHARACTERISTICS: $V_+ = 14.5\text{ V}$, $T_A = 25^\circ\text{C}$, unless otherwise noted

MOTOR DRIVE SECTION: (TEST CIRCUIT 3)

CHARACTERISTICS	CONDITIONS	MIN	TYP	MAX	UNITS
Input Offset Voltage				± 20	mV
Input Bias Current			0.1	10	μA
Common Mode Range		0.8		2.5	V
Driver Saturation	$I_g + I_{10} = 2\text{ A}$, $I_{11} = 175\text{ mA}$		1.9	2.5	V
Driver Leakage Current	$V_{11} = 16\text{ V}$			5.0	μA
Motor Drive Output Saturation	$I_g + I_{10} = 2\text{ A}$, $I_{11} = 55\text{ mA}$		0.6	1.1	V
Motor Drive Output Leakage	$V_8 = V_9 = V_{10} = 16\text{ V}$			100	μA
Flyback Diode Leakage	$V_9 = V_{10} = 1\text{ V}$			30	μA
Flyback Diode Clamp	$I_g + I_{10} = 2\text{ A}$ Motor Drive Output Off		1.6	2.5	V

ELECTRICAL CHARACTERISTICS: $V_+ = 14.5\text{ V}$, $T_A = 25^\circ\text{C}$, unless otherwise noted

PROTECTIVE CIRCUITS: (TEST CIRCUIT 4)

CHARACTERISTICS	CONDITIONS	MIN	TYP	MAX	UNITS
Thermal Shutdown Junction Temperature	Note 4		160		$^\circ\text{C}$
Overvoltage Shutdown	Note 4	18	21	24	V
Stall Timer Threshold Voltage	Note 5	2.5	2.9	3.5	V
Stall Timer Threshold Current	Note 5		0.3	3.0	μA

NOTES:

1. Frequency-to-Voltage Conversion, Supply Voltage Stability is defined as:

$$\left[\frac{V_{FV}(16\text{ V})}{V_7(16\text{ V})} \right] - \left[\frac{V_{FV}(10\text{ V})}{V_7(10\text{ V})} \right] \div \left[\frac{V_{FV}(14.5\text{ V})}{V_7(14.5\text{ V})} \right] \times 100\%$$

2. V_{FV} is the integrated dc output voltage from the pulse generator (Pin 6)
 3. Frequency-to-Voltage Conversion Temperature Stability is defined as:

$$\left[\frac{V_{FV}(85^\circ\text{C})}{V_7(85^\circ\text{C})} \right] - \left[\frac{V_{FV}(-40^\circ\text{C})}{V_7(-40^\circ\text{C})} \right] \div \left[\frac{V_{FV}(25^\circ\text{C})}{V_7(25^\circ\text{C})} \right] \times 100\%$$

4. "Driver" and "Motor Drive" circuitry is disabled when these limits are exceeded. If the condition continues for the duration set by the external stall timer components, the circuit is latched off until reset by temporarily opening the power supply input line.
 5. If stall timer protection is not required, Pin 12 should be grounded.

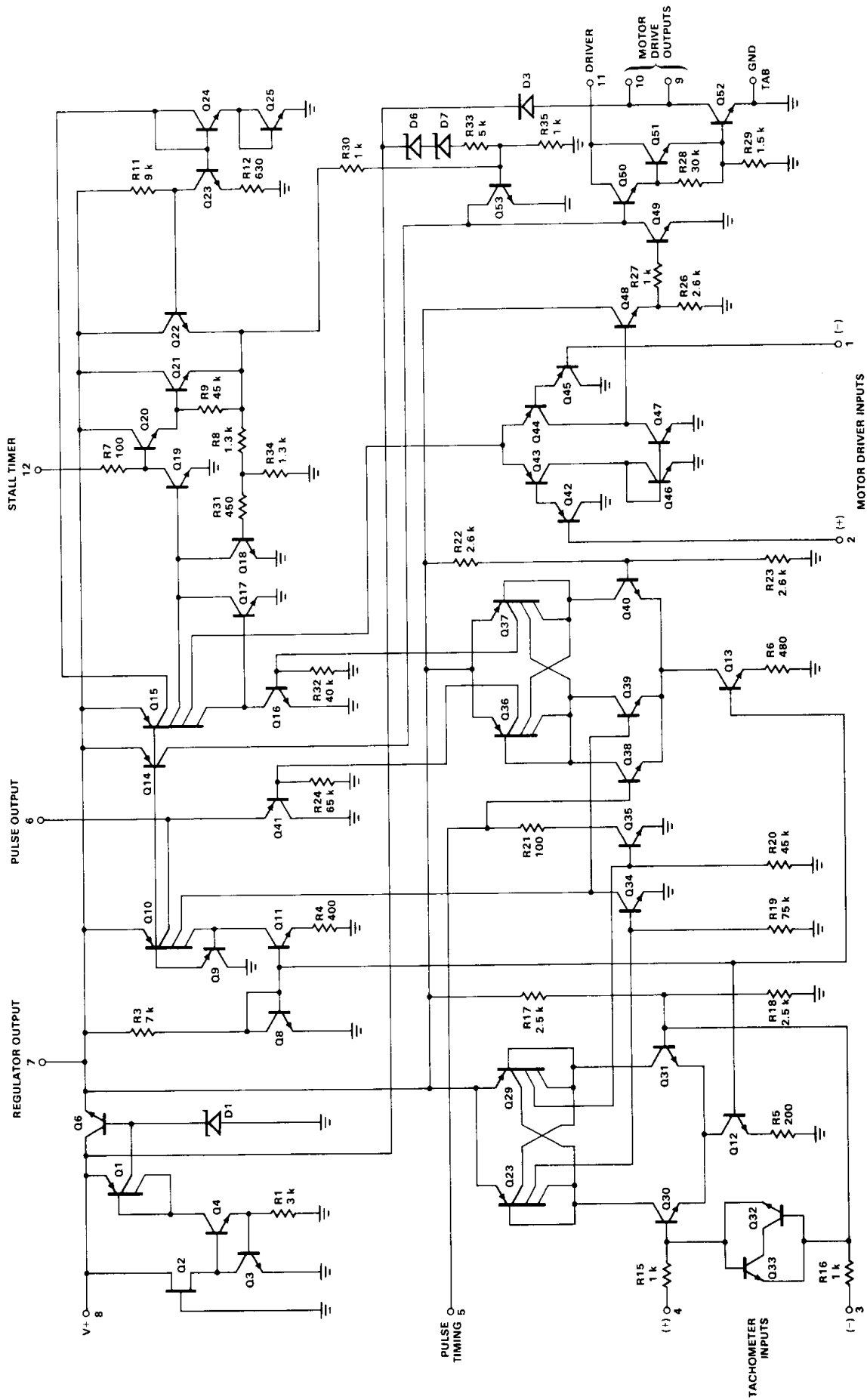

EQUIVALENT CIRCUIT

TYPICAL APPLICATION USING MAGNETIC TACHOMETER

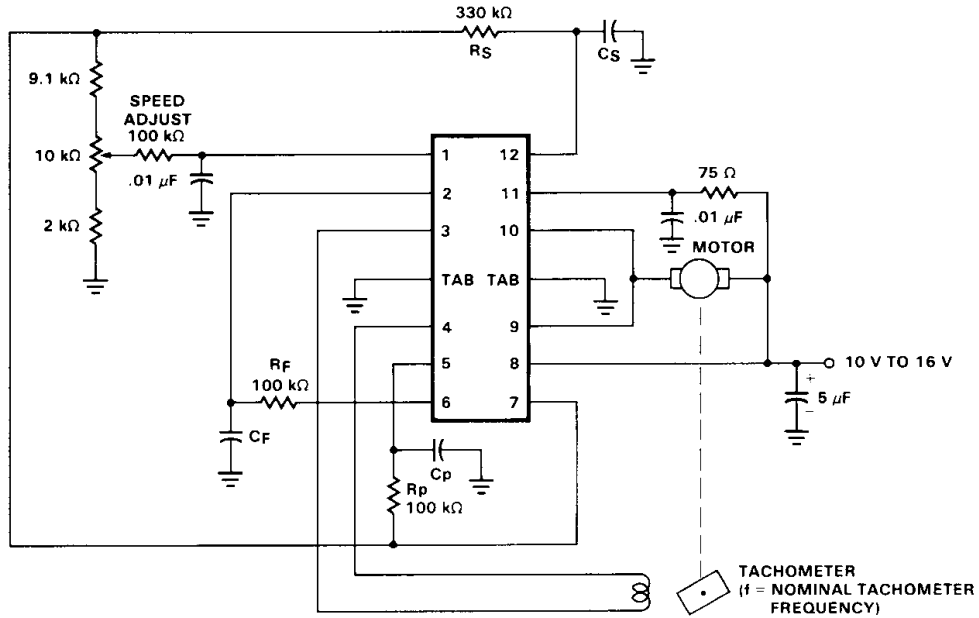

TYPICAL COMPONENT VALUES:

$$C_p = \frac{1}{4 R_{pf}}$$

$C_F = 10 C_p$ to $1000 C_p$ depending on system requirements

$$C_S = \frac{2 \times \text{stall time-out}}{R_S}$$

$$R_{\text{Motor}} \geq 5 \Omega$$

MOTOR SPEED ACCURACY AS A FUNCTION OF SUPPLY VOLTAGE
(REFER TO APPLICATION SCHEMATIC)

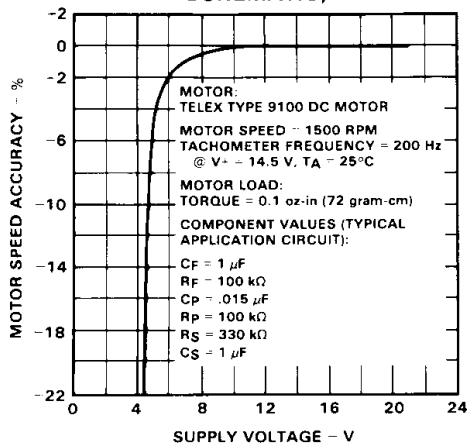

SUPPLY CURRENT AS A FUNCTION OF SUPPLY VOLTAGE

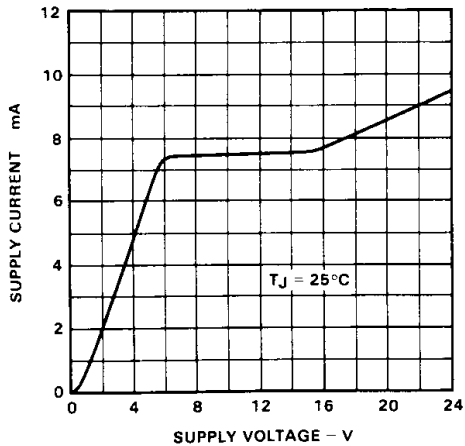

REGULATOR OUTPUT VOLTAGE AS A FUNCTION OF SUPPLY VOLTAGE

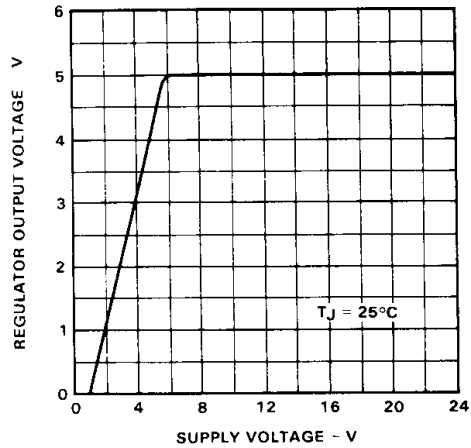

REGULATOR OUTPUT VOLTAGE AS A FUNCTION OF JUNCTION TEMPERATURE

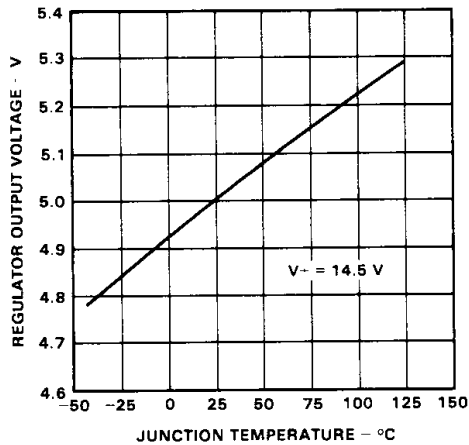

TACHOMETER INPUT HYSTERESIS AS A FUNCTION OF JUNCTION TEMPERATURE

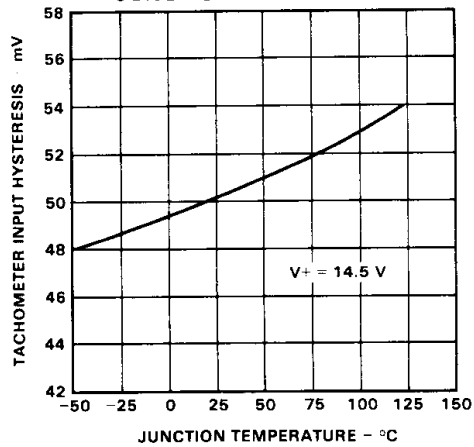

DRIVER ON CURRENT AS A FUNCTION OF DRIVER ON VOLTAGE

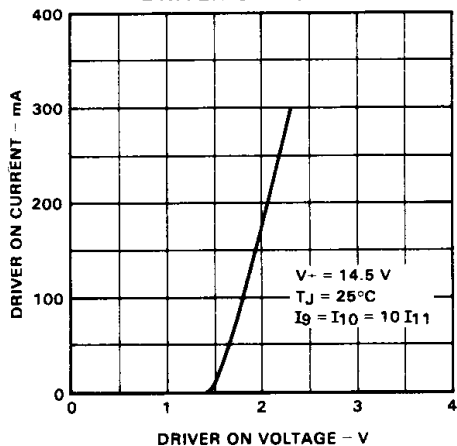

DRIVER ON VOLTAGE AS A FUNCTION OF JUNCTION TEMPERATURE

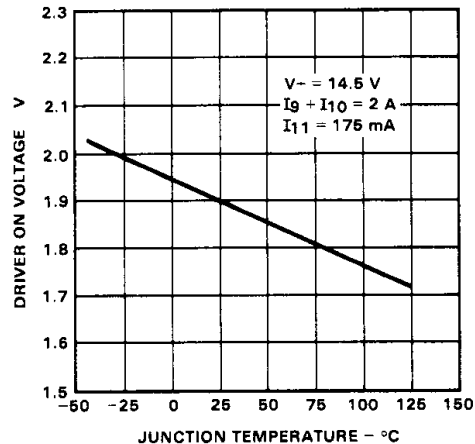

MOTOR DRIVE OUTPUT ON CURRENT AS A FUNCTION OF MOTOR DRIVE OUTPUT ON VOLTAGE

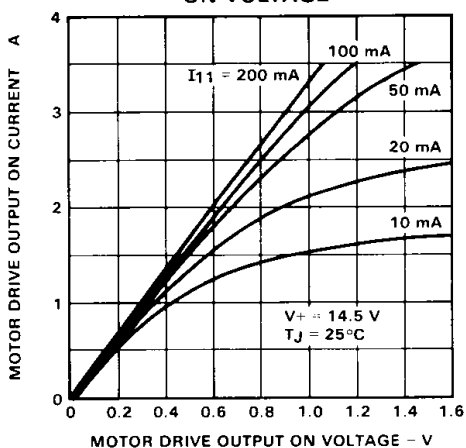

MOTOR DRIVE OUTPUT ON VOLTAGE AS A FUNCTION OF JUNCTION TEMPERATURE

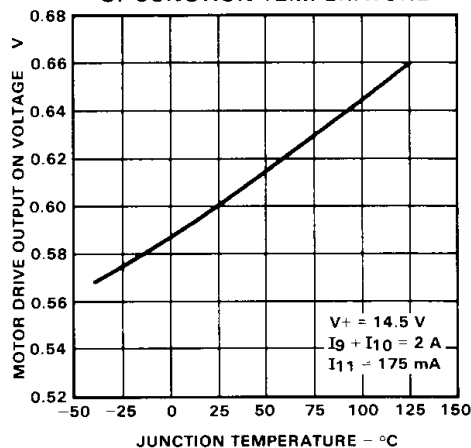

FLYBACK DIODE (D3) CURRENT AS A FUNCTION OF FLYBACK DIODE VOLTAGE

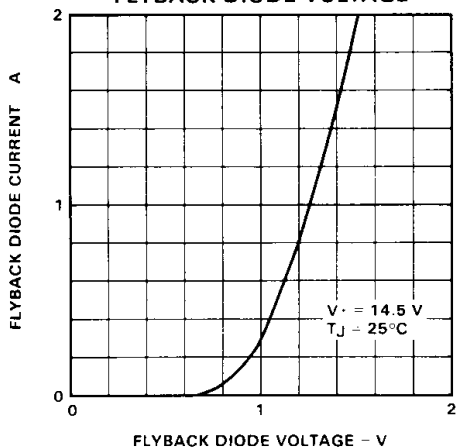

OVERVOLTAGE SHUTDOWN VOLTAGE AS A FUNCTION OF JUNCTION TEMPERATURE

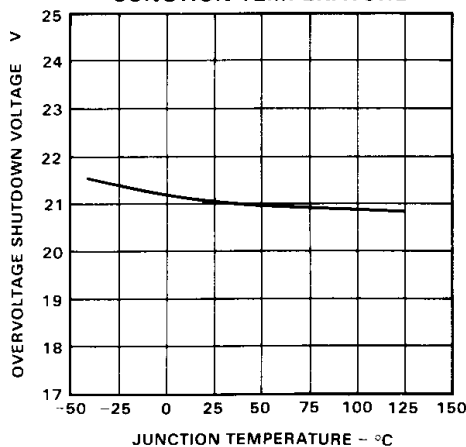

STALL TIMER THRESHOLD VOLTAGE AS A FUNCTION OF JUNCTION TEMPERATURE

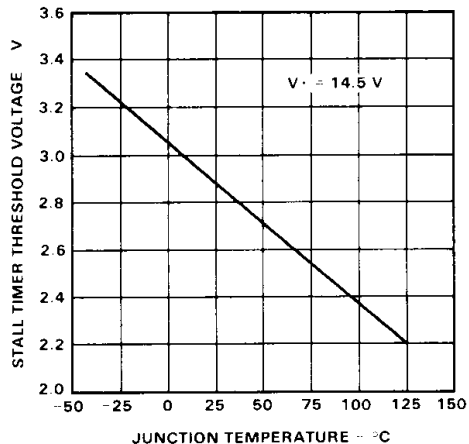

STALL TIMER THRESHOLD CURRENT AS A FUNCTION OF JUNCTION TEMPERATURE

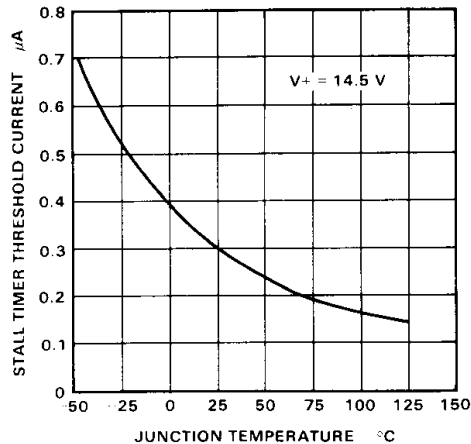

TEST CIRCUIT 1

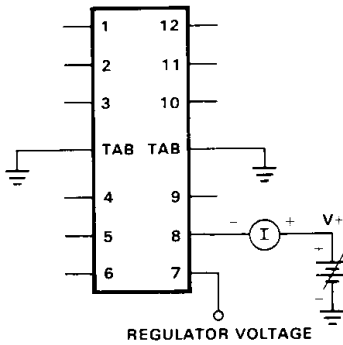

TEST CIRCUIT 2

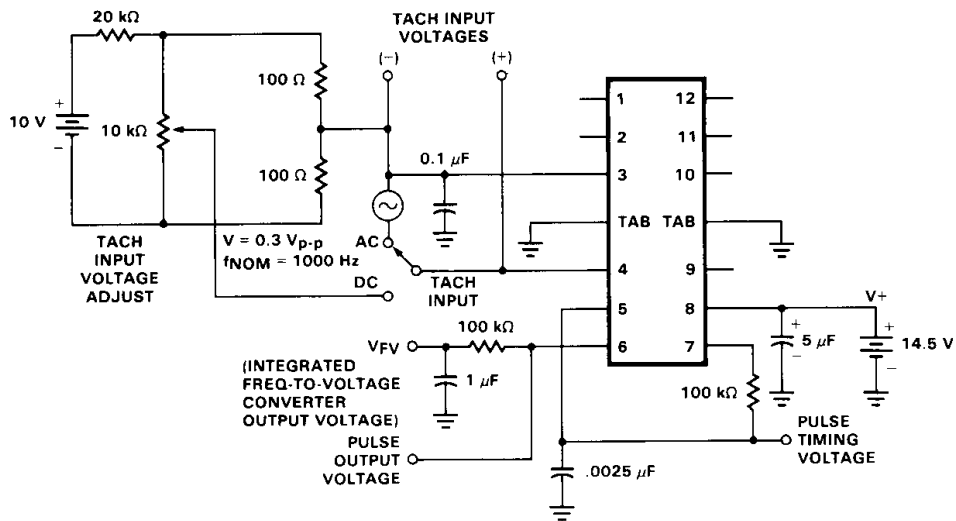

7

TEST CIRCUIT 3

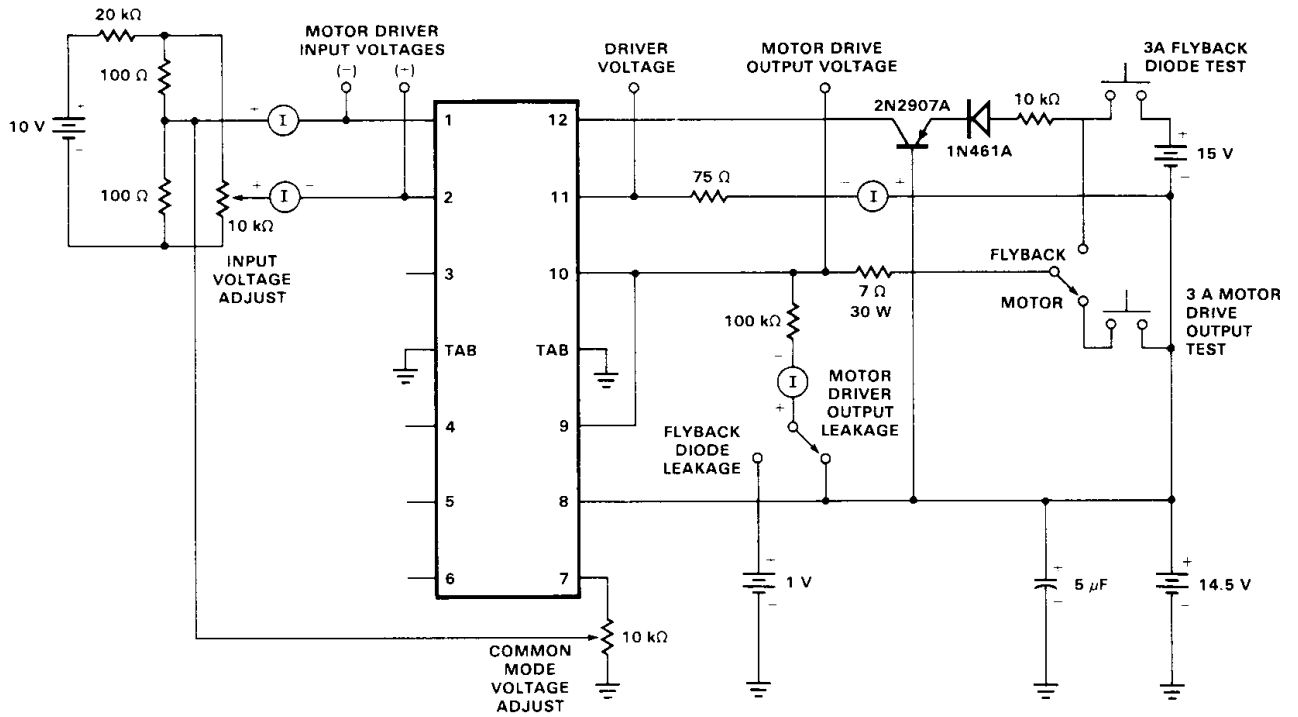

TEST CIRCUIT 4

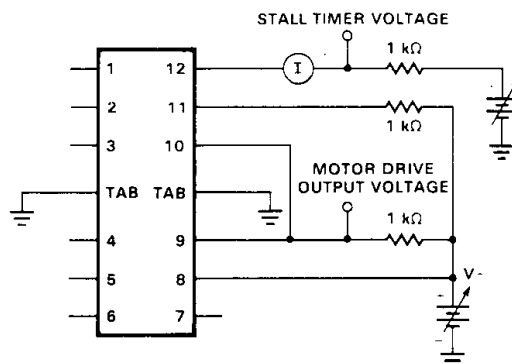

MOUNTING INSTRUCTIONS

The thermal power dissipated in the circuit may be removed by soldering the tabs to an area of copper on the printed circuit board. During soldering the tabs temperature must not exceed 260°C and the soldering temperature time must not be longer than 10 seconds.

MAXIMUM POWER DISSIPATION AS A FUNCTION OF AMBIENT TEMPERATURE

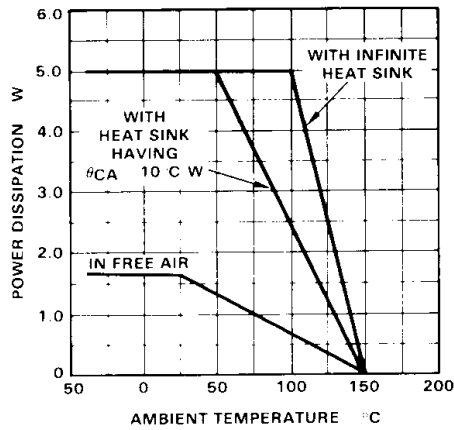

PC BOARD

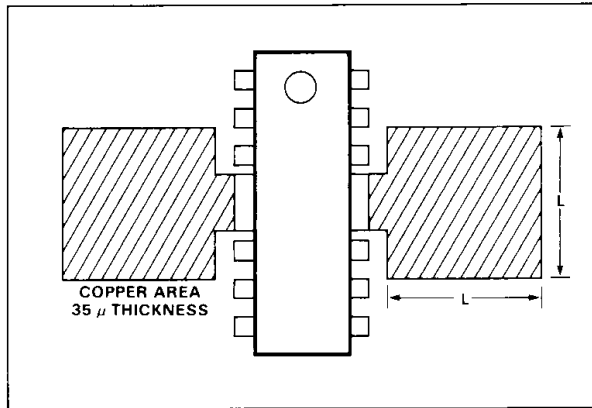

MAXIMUM POWER DISSIPATION AND TOTAL THERMAL RESISTANCE AS A FUNCTION OF COPPER AREA OF PC BOARD

