

November 1996

Features

- Programmability
- High Rate Slew 30V/ μ s
- Wide Gain Bandwidth 40MHz
- High Gain 150kV/V
- Low Offset Current 5nA
- High Input Impedance 30M Ω
- Single Capacitor Compensation
- DTL/TTL Compatible Inputs

Applications

- Thousands of Applications; Program
 - Signal Selection/Multiplexing
 - Operational Amplifier Gain
 - Oscillator Frequency
 - Filter Characteristics
 - Add-Subtract Functions
 - Integrator Characteristics
 - Comparator Levels

Ordering Information

PART NUMBER	TEMP. RANGE (°C)	PACKAGE	PKG. NO.
HA1-2400-2	-55 to 125	16 Ld Cerdip	F16.3
HA1-2404-4	-25 to 85	16 Ld Cerdip	F16.3
HA1-2405-5	0 to 75	16 Ld Cerdip	F16.3
HA3-2405-5	0 to 75	16 Ld Pdip	E16.3

Description

THA-2400/04/05 comprise a series of four-channel programmable amplifiers providing a level of versatility unsurpassed by any other monolithic operational amplifier. Versatility is achieved by employing four input amplifier channels, any one (or none) of which may be electronically selected and connected to a single output stage through DTL/TTL compatible address inputs. The device formed by the output and the selected pair of inputs is an op amp which delivers excellent slew rate, gain bandwidth and power bandwidth performance. Other advantageous features for these dielectrically isolated amplifiers include high voltage gain and input impedance coupled with low input offset voltage and offset current. External compensation is not required on this device at closed loop gains greater than 10.

Each channel of the HA-2400/04/05 can be controlled and operated with suitable feedback networks in any of the standard op amp configurations. This specialization makes these amplifiers excellent components for multiplexing signal selection and mathematical function designs. With 30V/ μ s slew rate, 40MHz gain bandwidth and 30M Ω input impedance these devices are ideal building blocks for signal generators, active filters and data acquisition designs. Programmability, coupled with 4mV typical offset voltage and 5nA offset current, makes these amplifiers outstanding components for signal conditioning circuits.

During Disable Mode V_{OUT} goes to V_- . For high output impedance during Disable, see HA2444.

For further design ideas, see Application Note AN514.

Pinout

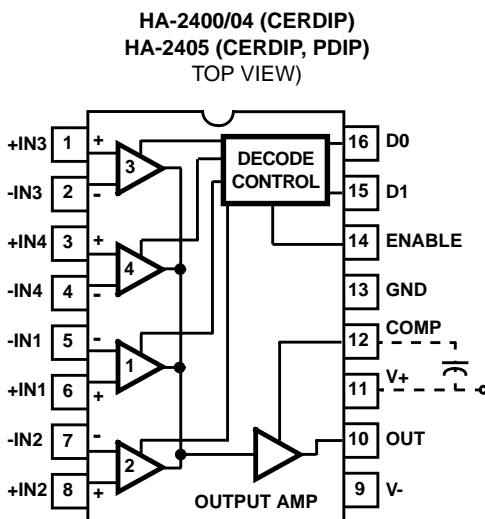

TRUTH TABLE

D1	D0	EN	SELECTED CHANNEL	D1
L	L	H	1	L
L	H	H	2	L
H	L	H	3	H
H	H	H	4	H
X	X	L	None, V_{OUT} goes to V_-	X

HA-2400, HA-2404, HA-2405

Absolute Maximum Ratings $T_A = 25^\circ\text{C}$

Voltage Between V+ and V- Terminals	45.0V
Differential Input Voltage	V_{SUPPLY}
Digital Input Voltage	-0.76V to +10.0V
Output Current	Short Circuit Protected, $I_{\text{SC}} < \pm 33\text{mA}$
Internal Power Dissipation (Note 1)	

Thermal Information

Thermal Resistance (Typical, Note 2)	θ_{JA} ($^\circ\text{C}/\text{W}$)	θ_{JC} ($^\circ\text{C}/\text{W}$)
PDIP Package	80	N/A
CERDIP Package	90	35
Maximum Junction Temperature (Ceramic Package)	175 $^\circ\text{C}$	
Maximum Junction Temperature (Plastic Package)	150 $^\circ\text{C}$	
Maximum Storage Temperature Range	-65 $^\circ\text{C}$ to 150 $^\circ\text{C}$	
Maximum Lead Temperature (Soldering 10s)	300 $^\circ\text{C}$	

Operating Conditions

Temperature Range	
HA-2400-2	-55 $^\circ\text{C}$ to 125 $^\circ\text{C}$
HA-2404-4	-25 $^\circ\text{C}$ to 85 $^\circ\text{C}$
HA-2405-5	0 $^\circ\text{C}$ to 75 $^\circ\text{C}$

CAUTION: Stresses above those listed in "Absolute Maximum Ratings" may cause permanent damage to the device. This is a stress only rating and operation of the device at these or any other conditions above those indicated in the operational sections of this specification is not implied.

NOTES:

- Maximum power dissipation including output load, must be designed to maintain the junction temperature below 175 $^\circ\text{C}$ for the ceramic package, and below 150 $^\circ\text{C}$ for the plastic packages.
- θ_{JA} is measured with the component mounted on an evaluation PC board in free air.

Electrical Specifications Test Conditions: $V_{\text{SUPPLY}} = \pm 15\text{V}$, Unless Otherwise Specified. Digital Inputs: $V_{\text{IL}} = +0.5\text{V}$, $V_{\text{IH}} = +2.4$. Limits apply to each of the four channels, when addressed

PARAMETER	TEST CONDITIONS	TEMP. ($^\circ\text{C}$)	HA-2400/04			HA-2405			UNITS
			MIN	TYP	MAX	MIN	TYP	MAX	
INPUT CHARACTERISTICS									
Offset Voltage		25	-	4	9	-	4	9	mV
		Full	-	-	11	-	-	11	mV
Bias Current (Note 8)		25	-	50	200	-	50	250	nA
		Full	-	-	400	-	-	500	nA
Offset Current (Note 8)		25	-	5	50	-	5	50	nA
		Full	-	-	100	-	-	100	nA
Input Resistance (Note 8)		25	-	30	-	-	30	-	M Ω
Common Mode Range		Full	± 9.0	-	-	± 9.0	-	-	V
TRANSFER CHARACTERISTICS									
Large Signal Voltage Gain	$R_L = 2\text{k}\Omega$ $V_{\text{OUT}} = 20\text{V}_{\text{P-P}}$	25	50	150	-	50	150	-	kV/V
		Full	25	-	-	25	-	-	kV/V
Common Mode Rejection Ratio	$V_{\text{CM}} = \pm 5\text{V}$	Full	80	100	-	74	100	-	dB
Gain Bandwidth (Notes 3, 9)		25	20	40	-	20	40	-	MHz
Gain Bandwidth (Notes 4, 9)		25	4	8	-	4	8	-	MHz
Minimum Stable Gain	$(C_{\text{COMP}} = 0)$		10	-	-	10	-	-	V/V
OUTPUT CHARACTERISTICS									
Output Voltage Swing	$R_L = 2\text{k}\Omega$	Full	± 10.0	± 12.0	-	± 10.0	± 12.0	-	V
Output Current		25	10	20	-	10	20	-	mA
Full Power Bandwidth (Notes 3, 10)	$V_{\text{OUT}} = 20\text{V}_{\text{P-P}}$	25	640	950	-	640	950	-	kHz
Full Power Bandwidth (Notes 4, 10)	$V_{\text{OUT}} = 20\text{V}_{\text{P-P}}$	25	200	250	-	200	250	-	kHz
TRANSIENT RESPONSE (Note 11)									
Rise Time (Note 4)	$V_{\text{OUT}} = 200\text{mV}_{\text{PEAK}}$	25	-	20	45	-	20	50	ns
Overshoot (Note 4)	$V_{\text{OUT}} = 200\text{mV}_{\text{PEAK}}$	25	-	25	40	-	25	40	%
Slew Rate (Note 3)	$V_{\text{OUT}} = 10\text{V}_{\text{P-P}}$	25	20	30	-	20	30	-	V/ μs
Slew Rate (Notes 4, 9)	$V_{\text{OUT}} = 10\text{V}_{\text{P-P}}$	25	6	8	-	6	8	-	V/ μs

HA-2400, HA-2404, HA-2405

Electrical Specifications Test Conditions: $V_{SUPPLY} = \pm 15V$, Unless Otherwise Specified. Digital Inputs: $V_{IL} = +0.5V$, $V_{IH} = +2.4$. Limits apply to each of the four channels, when addressed **(Continued)**

PARAMETER	TEST CONDITIONS	TEMP. (°C)	HA-2400/04			HA-2405			UNITS
			MIN	TYP	MAX	MIN	TYP	MAX	
Settling Time (Notes 4, 5, 9)	$V_{OUT} = 10V_{P-P}$	25	-	1.5	2.5	-	1.5	2.5	μs
CHANNEL SELECT CHARACTERISTICS									
Digital Input Current	$V_{IN} = 0V$	Full	-	1	1.5	-	1	1.5	mA
Digital Input Current	$V_{IN} = +5.0V$	Full	-	5	-	-	5	-	nA
Output Delay (Notes 6, 9)		25	-	100	250	-	100	250	ns
Crosstalk (Note 7)		25	-80	-110	-	-74	-110	-	dB
POWER SUPPLY CHARACTERISTICS									
Supply Current		25	-	4.8	6.0	-	4.8	6.0	mA
Power Supply Rejection Ratio	$V_S = \pm 10V$ to $\pm 20V$	Full	74	90	-	74	90	-	dB

NOTES:

- $A_V = +10$, $C_{COMP} = 0$, $R_L = 2k\Omega$, $C_L = 50pF$.
- $A_V = +1$, $C_{COMP} = 15pF$, $R_L = 2k\Omega$, $C_L = 50pF$.
- To 0.1% of final value.
- To 10% of final value; output then slews at normal rate to final value.
- Unselected input to output; $V_{IN} = \pm 10V_{DC}$.
- Unselected channels have approximately the same input parameters.
- Guaranteed by design.
- Full Power Bandwidth based on slew rate measurement using: $FPBW = \frac{SR}{2\pi V_{PEAK}}$; $V_{PEAK} = 5V$.
- See Figure 13 for test circuit.

Schematic Diagram

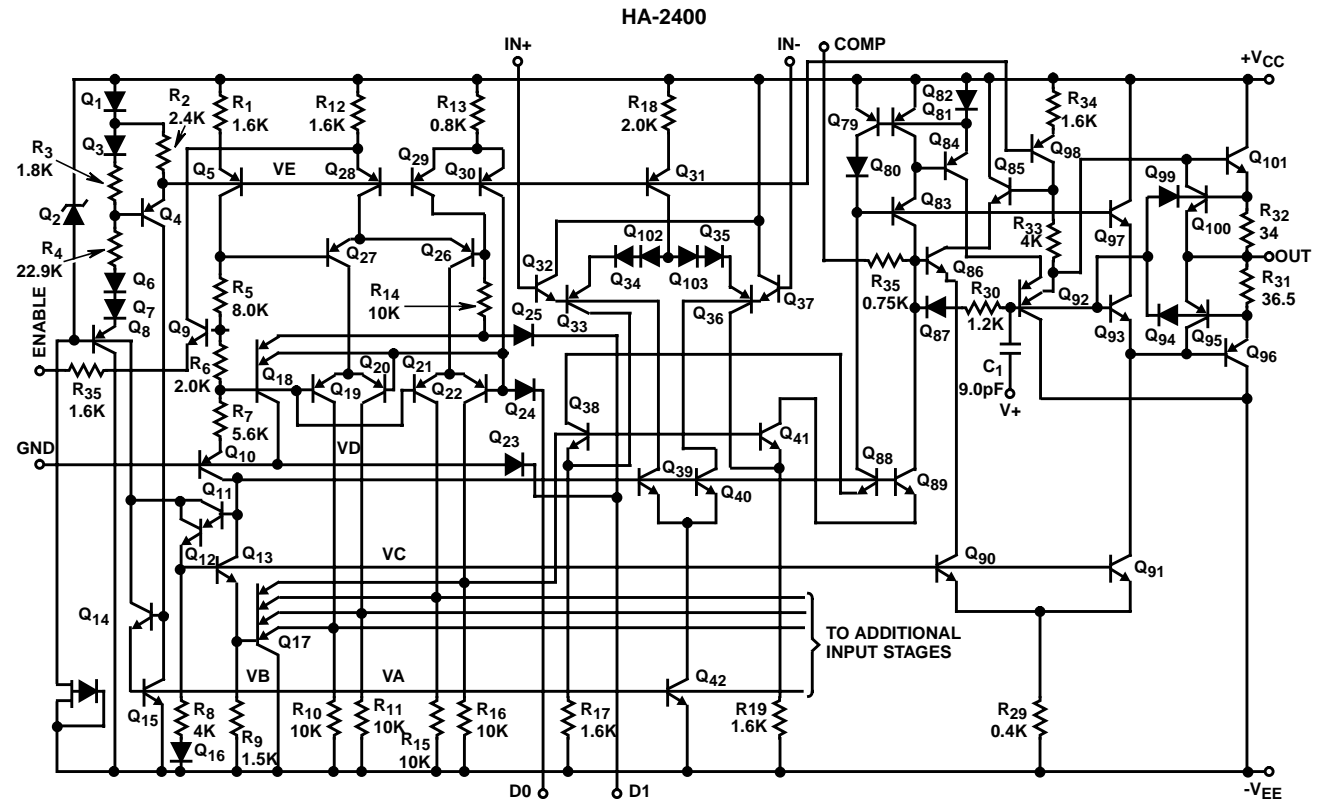

Diagram Includes: One Input Stage, Decode Control, Bias Network, and Output Stage

Typical Applications

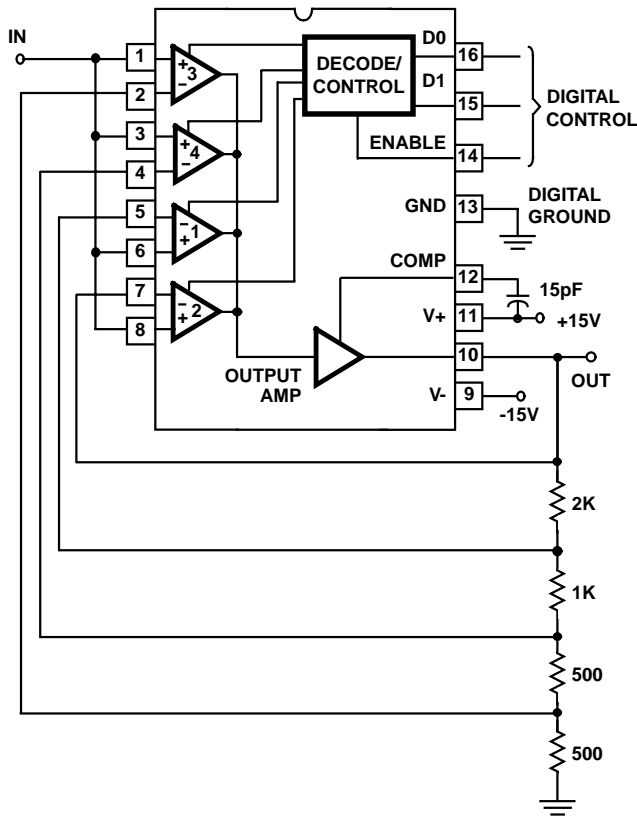
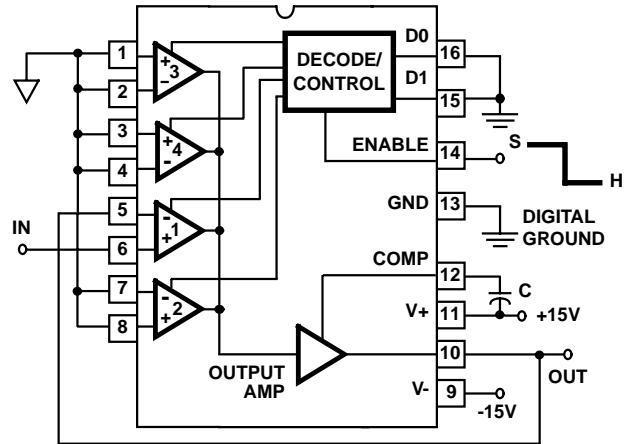

FIGURE 1. HA-2400 AMPLIFIER, NONINVERTING PROGRAMMABLE GAIN



$$\text{Sample Charging Rate} = \frac{I_1}{C} \text{V/s}$$

$$\text{Hold Drift Rate} = \frac{I_2}{C} \text{V/s}$$

$$\text{Switch Pedestal Error} = \frac{Q}{C} \text{V}$$

$$I_1 \approx 150 \times 10^{-6} \text{A}$$

$$I_2 \approx 200 \times 10^{-9} \text{A at } 25^\circ\text{C}$$

$$\approx 600 \times 10^{-9} \text{A at } -55^\circ\text{C}$$

$$\approx 100 \times 10^{-9} \text{A at } 125^\circ\text{C}$$

$$Q \approx 2 \times 10^{-12} \text{C}$$

FIGURE 2. HA-2400 SAMPLE AND HOLD

For more examples, see Intersil Application Note AN514.

Typical Performance Curves

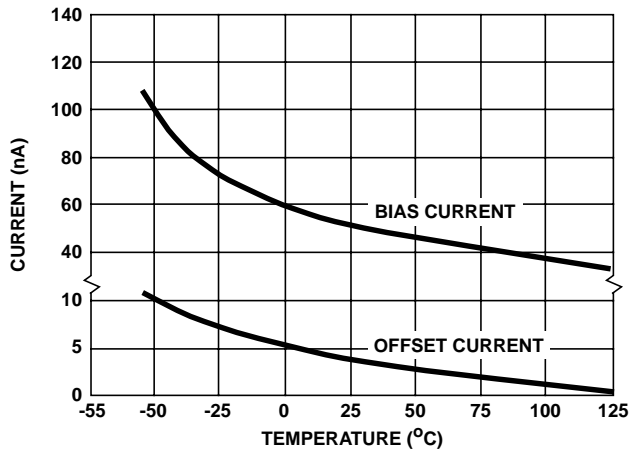

FIGURE 3. INPUT BIAS CURRENT AND OFFSET CURRENT vs TEMPERATURE

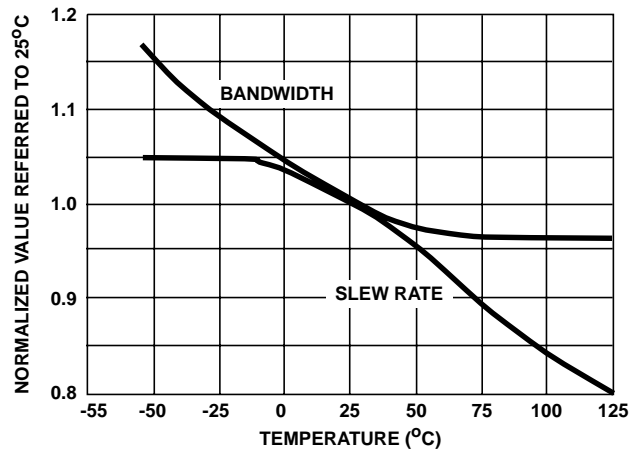

FIGURE 4. NORMALIZED AC PARAMETERS vs TEMPERATURE

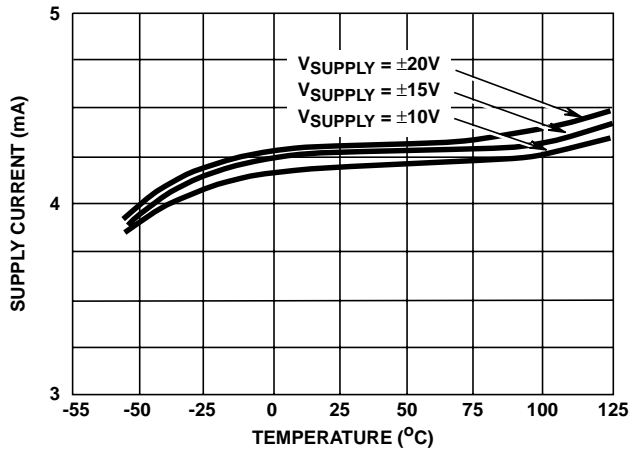

FIGURE 5. POWER SUPPLY CURRENT vs TEMPERATURE

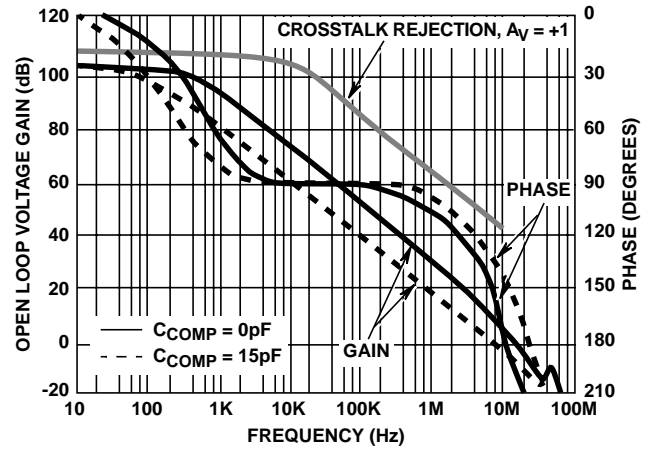

FIGURE 6. OPEN LOOP FREQUENCY AND PHASE RESPONSE

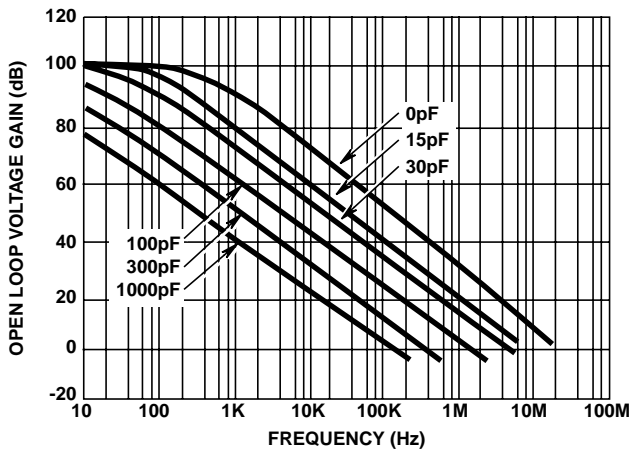

FIGURE 7. FREQUENCY RESPONSE vs C_{COMP}

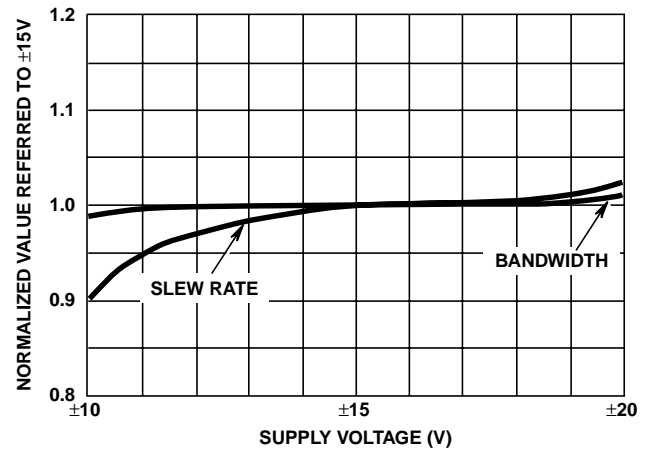

FIGURE 8. NORMALIZED AC PARAMETERS vs SUPPLY VOLTAGE

Typical Performance Curves (Continued)

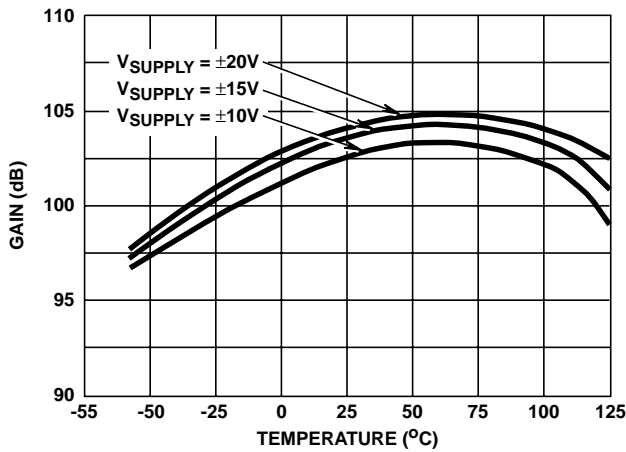

FIGURE 9. OPEN LOOP VOLTAGE GAIN vs TEMPERATURE

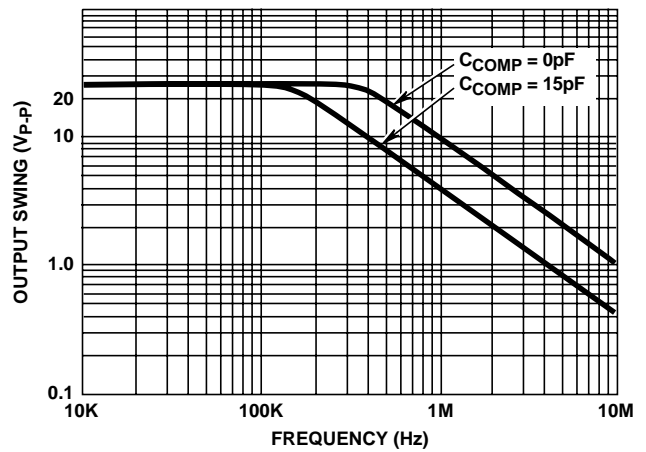

FIGURE 10. OUTPUT VOLTAGE SWING vs FREQUENCY

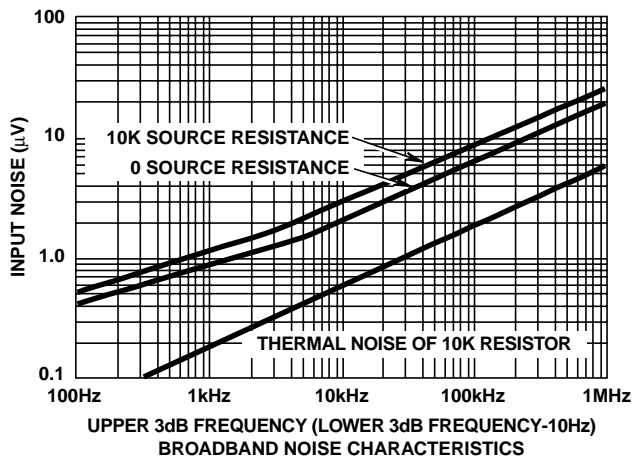

FIGURE 11. EQUIVALENT INPUT NOISE vs BANDWIDTH

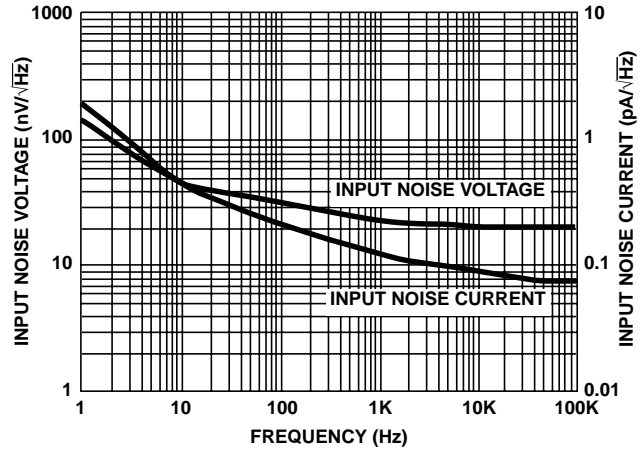

FIGURE 12. INPUT NOISE vs FREQUENCY

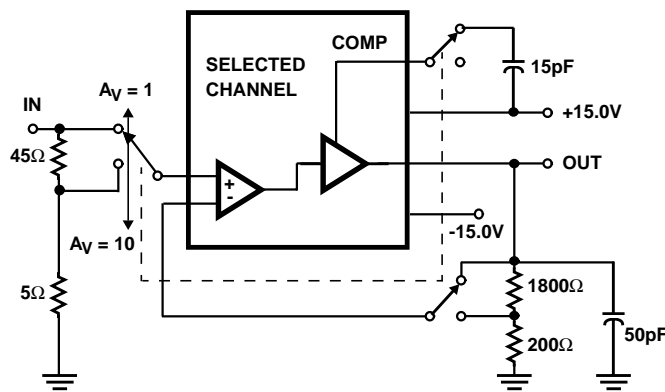

FIGURE 13. SLEW RATE AND TRANSIENT RESPONSE

All Intersil semiconductor products are manufactured, assembled and tested under **ISO9000** quality systems certification.

Intersil products are sold by description only. Intersil Corporation reserves the right to make changes in circuit design and/or specifications at any time without notice. Accordingly, the reader is cautioned to verify that data sheets are current before placing orders. Information furnished by Intersil is believed to be accurate and reliable. However, no responsibility is assumed by Intersil or its subsidiaries for its use; nor for any infringements of patents or other rights of third parties which may result from its use. No license is granted by implication or otherwise under any patent or patent rights of Intersil or its subsidiaries.

For information regarding Intersil Corporation and its products, see web site <http://www.intersil.com>

Sales Office Headquarters

NORTH AMERICA

Intersil Corporation
P. O. Box 883, Mail Stop 53-204
Melbourne, FL 32902
TEL: (321) 724-7000
FAX: (321) 724-7240

EUROPE

Intersil SA
Mercure Center
100, Rue de la Fusee
1130 Brussels, Belgium
TEL: (32) 2.724.2111
FAX: (32) 2.724.22.05

ASIA

Intersil (Taiwan) Ltd.
Taiwan Limited
7F-6, No. 101 Fu Hsing North Road
Taipei, Taiwan
Republic of China
TEL: (886) 2 2716 9310
FAX: (886) 2 2715 3029