

# NUD3124

## Automotive Inductive Load Driver

This MicroIntegration™ part provides a single component solution to switch inductive loads such as relays, solenoids, and small DC motors without the need of a free-wheeling diode. It accepts logic level inputs, thus allowing it to be driven by a large variety of devices including logic gates, inverters, and microcontrollers.

### Features

- Provides Robust Interface between D.C. Relay Coils and Sensitive Logic
- Capable of Driving Relay Coils Rated up to 150 mA at 12 Volts
- Replaces 3 or 4 Discrete Components for Lower Cost
- Internal Zener Eliminates Need for Free-Wheeling Diode
- Meets Load Dump and other Automotive Specs
- Pb-Free Packages are Available

### Typical Applications

- Automotive and Industrial Environment
- Drives Window, Latch, Door, and Antenna Relays

### Benefits

- Reduced PCB Space
- Standardized Driver for Wide Range of Relays
- Simplifies Circuit Design and PCB Layout
- Compliance with Automotive Specifications



**ON Semiconductor®**

<http://onsemi.com>

### MARKING DIAGRAMS



**SOT-23  
CASE 318  
STYLE 21**

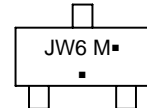

JW6 = Specific Device Code  
M = Date Code  
▪ = Pb-Free Package  
(Note: Microdot may be in either location)



**SC-74  
CASE 318F  
STYLE 7**

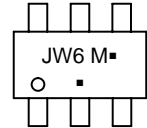

JW6 = Specific Device Code  
M = Date Code  
▪ = Pb-Free Package  
(Note: Microdot may be in either location)

### ORDERING INFORMATION

Device	Package	Shipping†
NUD3124LT1	SOT-23	3000/Tape & Reel
NUD3124LT1G	SOT-23 (Pb-Free)	3000/Tape & Reel
NUD3124DMT1	SC-74	3000/Tape & Reel
NUD3124DMT1G	SC-74 (Pb-Free)	3000/Tape & Reel

†For information on tape and reel specifications, including part orientation and tape sizes, please refer to our Tape and Reel Packaging Specification Brochure, BRD8011/D.

### INTERNAL CIRCUIT DIAGRAMS

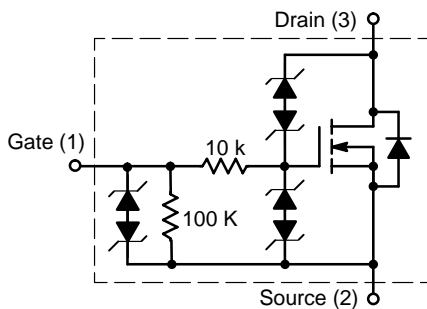

CASE 318

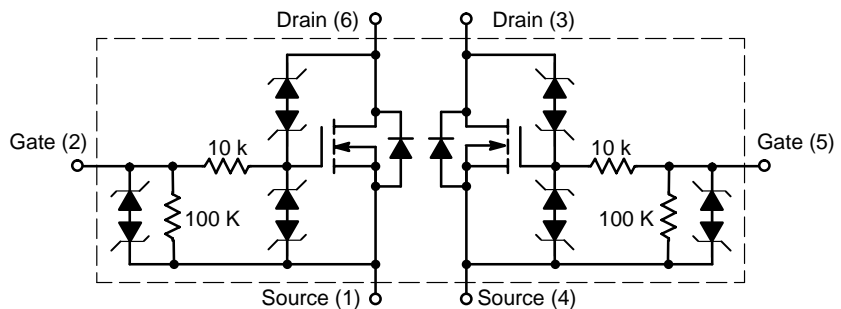

CASE 318F

# NUD3124

## MAXIMUM RATINGS (T<sub>J</sub> = 25°C unless otherwise specified)

Symbol	Rating	Value	Unit
V <sub>DSS</sub>	Drain-to-Source Voltage – Continuous (T <sub>J</sub> = 125°C)	28	V
V <sub>GSS</sub>	Gate-to-Source Voltage – Continuous (T <sub>J</sub> = 125°C)	12	V
I <sub>D</sub>	Drain Current – Continuous (T <sub>J</sub> = 125°C)	150	mA
E <sub>Z</sub>	Single Pulse Drain-to-Source Avalanche Energy (For Relay's Coils/Inductive Loads of 80 Ω or Higher) (T <sub>J</sub> Initial = 85°C)	250	mJ
P <sub>PK</sub>	Peak Power Dissipation, Drain-to-Source (Notes 1 and 2) (T <sub>J</sub> Initial = 85°C)	20	W
E <sub>LD1</sub>	Load Dump Suppressed Pulse, Drain-to-Source (Notes 3 and 4) (Suppressed Waveform: V <sub>s</sub> = 45 V, R <sub>SOURCE</sub> = 0.5 Ω, T = 200 ms) (For Relay's Coils/Inductive Loads of 80 Ω or Higher) (T <sub>J</sub> Initial = 85°C)	80	V
E <sub>LD2</sub>	Inductive Switching Transient 1, Drain-to-Source (Waveform: R <sub>SOURCE</sub> = 10 Ω, T = 2.0 ms) (For Relay's Coils/Inductive Loads of 80 Ω or Higher) (T <sub>J</sub> Initial = 85°C)	100	V
E <sub>LD3</sub>	Inductive Switching Transient 2, Drain-to-Source (Waveform: R <sub>SOURCE</sub> = 4.0 Ω, T = 50 μs) (For Relay's Coils/Inductive Loads of 80 Ω or Higher) (T <sub>J</sub> Initial = 85°C)	300	V
Rev-Bat	Reverse Battery, 10 Minutes (Drain-to-Source) (For Relay's Coils/Inductive Loads of 80 Ω or more)	-14	V
Dual-Volt	Dual Voltage Jump Start, 10 Minutes (Drain-to-Source)	28	V
ESD	Human Body Model (HBM) According to EIA/JESD22/A114 Specification	2,000	V

Maximum ratings are those values beyond which device damage can occur. Maximum ratings applied to the device are individual stress limit values (not normal operating conditions) and are not valid simultaneously. If these limits are exceeded, device functional operation is not implied, damage may occur and reliability may be affected.

1. Nonrepetitive current square pulse 1.0 ms duration.
2. For different square pulse durations, see Figure 2.
3. Nonrepetitive load dump suppressed pulse per Figure 3.
4. For relay's coils/inductive loads higher than 80 Ω, see Figure 4.

## THERMAL CHARACTERISTICS

Symbol	Rating	Value	Unit	
T <sub>A</sub>	Operating Ambient Temperature	-40 to 125	°C	
T <sub>J</sub>	Maximum Junction Temperature	150	°C	
T <sub>STG</sub>	Storage Temperature Range	-65 to 150	°C	
P <sub>D</sub>	Total Power Dissipation (Note 5) Derating above 25°C	SOT-23	225	mW
			1.8	mW/°C
P <sub>D</sub>	Total Power Dissipation (Note 5) Derating above 25°C	SC-74	380	mW
			3.0	mW/°C
R <sub>θJA</sub>	Thermal Resistance Junction-to-Ambient (Note 5)	SOT-23	556	°C/W
		SC-74	329	

5. Mounted onto minimum pad board.

# NUD3124

## ELECTRICAL CHARACTERISTICS (T<sub>J</sub> = 25°C unless otherwise specified)

Characteristic	Symbol	Min	Typ	Max	Unit
<b>OFF CHARACTERISTICS</b>					
Drain to Source Sustaining Voltage (I <sub>D</sub> = 10 mA)	V <sub>BRDSS</sub>	28	34	38	V
Drain to Source Leakage Current (V <sub>DS</sub> = 12 V, V <sub>GS</sub> = 0 V) (V <sub>DS</sub> = 12 V, V <sub>GS</sub> = 0 V, T <sub>J</sub> = 125°C) (V <sub>DS</sub> = 28 V, V <sub>GS</sub> = 0 V) (V <sub>DS</sub> = 28 V, V <sub>GS</sub> = 0 V, T <sub>J</sub> = 125°C)	I <sub>DSS</sub>	–	–	0.5 1.0 50 80	μA
Gate Body Leakage Current (V <sub>GS</sub> = 3.0 V, V <sub>DS</sub> = 0 V) (V <sub>GS</sub> = 3.0 V, V <sub>DS</sub> = 0 V, T <sub>J</sub> = 125°C) (V <sub>GS</sub> = 5.0 V, V <sub>DS</sub> = 0 V) (V <sub>GS</sub> = 5.0 V, V <sub>DS</sub> = 0 V, T <sub>J</sub> = 125°C)	I <sub>GSS</sub>	–	–	60 80 90 110	μA
<b>ON CHARACTERISTICS</b>					
Gate Threshold Voltage (V <sub>GS</sub> = V <sub>DS</sub> , I <sub>D</sub> = 1.0 mA) (V <sub>GS</sub> = V <sub>DS</sub> , I <sub>D</sub> = 1.0 mA, T <sub>J</sub> = 125°C)	V <sub>GS(th)</sub>	1.3 1.3	1.8 –	2.0 2.0	V
Drain to Source On-Resistance (I <sub>D</sub> = 150 mA, V <sub>GS</sub> = 3.0 V) (I <sub>D</sub> = 150 mA, V <sub>GS</sub> = 3.0 V, T <sub>J</sub> = 125°C) (I <sub>D</sub> = 150 mA, V <sub>GS</sub> = 5.0 V) (I <sub>D</sub> = 150 mA, V <sub>GS</sub> = 5.0 V, T <sub>J</sub> = 125°C)	R <sub>DS(on)</sub>	–	–	1.4 1.7 0.8 1.1	Ω
Output Continuous Current (V <sub>DS</sub> = 0.25 V, V <sub>GS</sub> = 3.0 V) (V <sub>DS</sub> = 0.25 V, V <sub>GS</sub> = 3.0 V, T <sub>J</sub> = 125°C)	I <sub>DS(on)</sub>	150 140	200 –	– –	mA
Forward Transconductance (V <sub>DS</sub> = 12 V, I <sub>D</sub> = 150 mA)	g <sub>FS</sub>	–	500	–	mmho
<b>DYNAMIC CHARACTERISTICS</b>					
Input Capacitance (V <sub>DS</sub> = 12 V, V <sub>GS</sub> = 0 V, f = 10 kHz)	C <sub>iss</sub>	–	32	–	pf
Output Capacitance (V <sub>DS</sub> = 12 V, V <sub>GS</sub> = 0 V, f = 10 kHz)	C <sub>oss</sub>	–	21	–	pf
Transfer Capacitance (V <sub>DS</sub> = 12 V, V <sub>GS</sub> = 0 V, f = 10 kHz)	C <sub>rss</sub>	–	8.0	–	pf
<b>SWITCHING CHARACTERISTICS</b>					
Propagation Delay Times: High to Low Propagation Delay; Figure 1, (V <sub>DS</sub> = 12 V, V <sub>GS</sub> = 3.0 V) Low to High Propagation Delay; Figure 1, (V <sub>DS</sub> = 12 V, V <sub>GS</sub> = 3.0 V)  High to Low Propagation Delay; Figure 1, (V <sub>DS</sub> = 12 V, V <sub>GS</sub> = 5.0 V) Low to High Propagation Delay; Figure 1, (V <sub>DS</sub> = 12 V, V <sub>GS</sub> = 5.0 V)	t <sub>PHL</sub> t <sub>PLH</sub>  t <sub>PHL</sub> t <sub>PLH</sub>	– –  – –	890 912  324 1280	– –  – –	ns
Transition Times: Fall Time; Figure 1, (V <sub>DS</sub> = 12 V, V <sub>GS</sub> = 3.0 V) Rise Time; Figure 1, (V <sub>DS</sub> = 12 V, V <sub>GS</sub> = 3.0 V)  Fall Time; Figure 1, (V <sub>DS</sub> = 12 V, V <sub>GS</sub> = 5.0 V) Rise Time; Figure 1, (V <sub>DS</sub> = 12 V, V <sub>GS</sub> = 5.0 V)	t <sub>f</sub> t <sub>r</sub>  t <sub>f</sub> t <sub>r</sub>	– –  – –	2086 708  556 725	– –  – –	ns

# NUD3124

## TYPICAL PERFORMANCE CURVES

( $T_J = 25^\circ\text{C}$  unless otherwise noted)

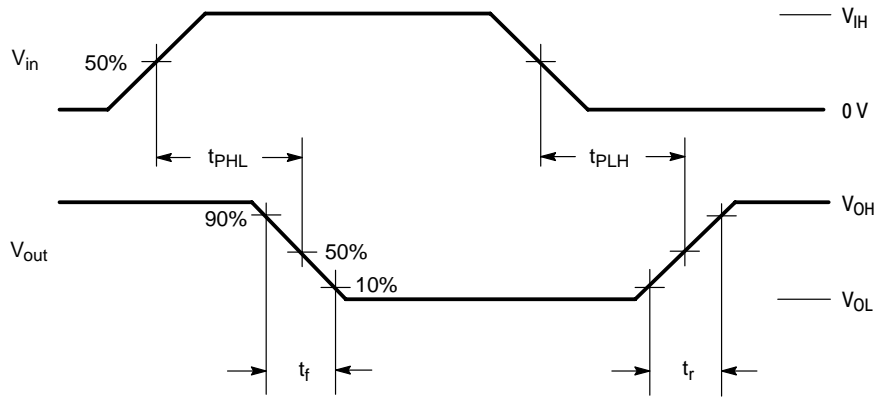

Figure 1. Switching Waveforms

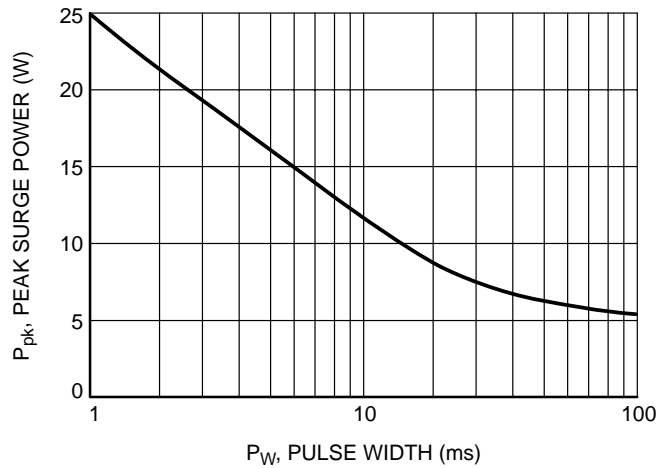

Figure 2. Maximum Non-repetitive Surge Power versus Pulse Width

**Load Dump Pulse Not Suppressed:**

$V_R = 13.5\text{ V Nominal } \pm 10\%$

$V_S = 60\text{ V Nominal } \pm 10\%$

$T = 300\text{ ms Nominal } \pm 10\%$

$T_R = 1 - 10\text{ ms } \pm 10\%$

**Load Dump Pulse Suppressed:**

NOTE: Max. Voltage DUT is exposed to is approximately 45 V.

$V_S = 30\text{ V } \pm 20\%$

$T = 150\text{ ms } \pm 20\%$

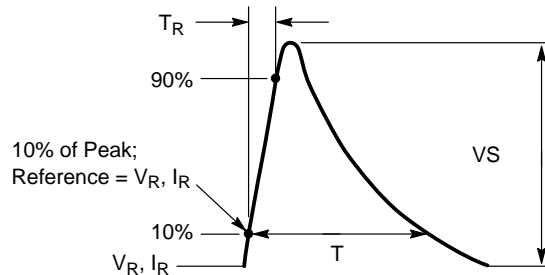

Figure 3. Load Dump Waveform Definition

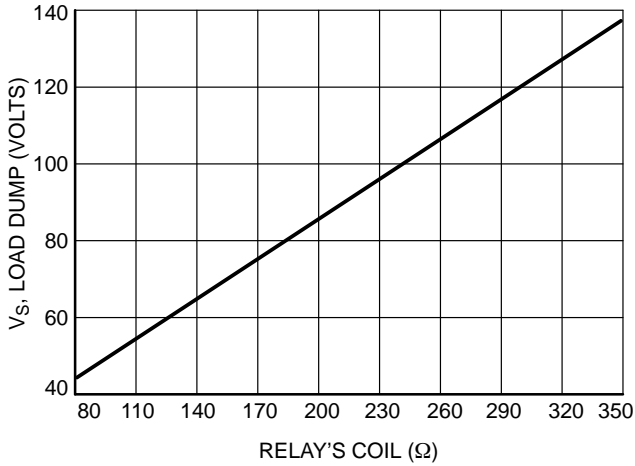

Figure 4. Load Dump Capability versus Relay's Coil dc Resistance

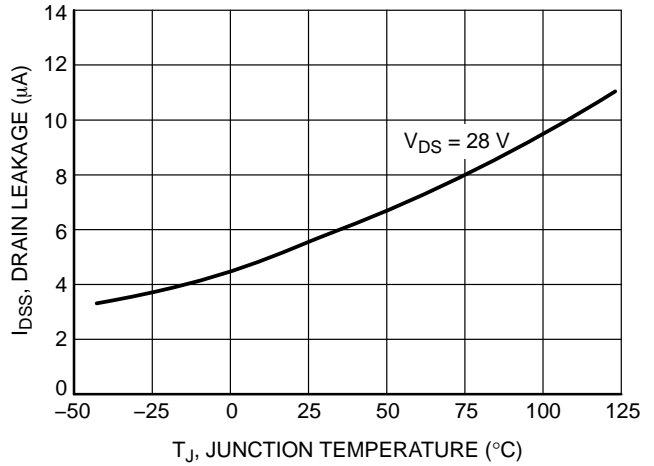

Figure 5. Drain-to-Source Leakage versus Junction Temperature

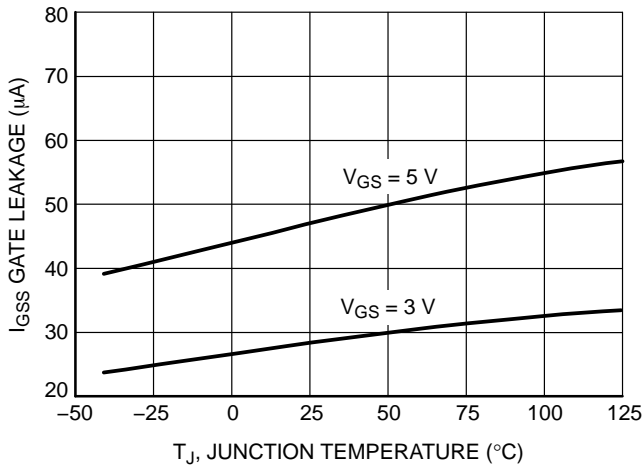

Figure 6. Gate-to-Source Leakage versus Junction Temperature

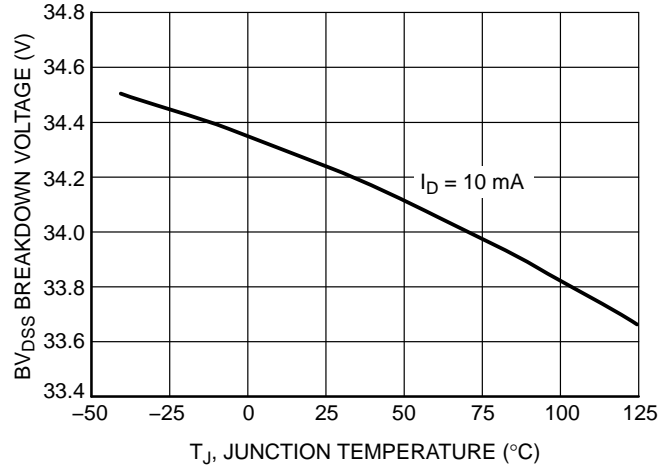

Figure 7. Breakdown Voltage versus Junction Temperature

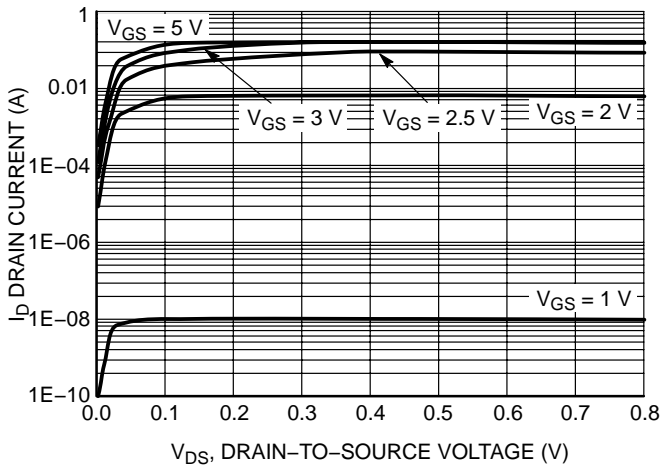

Figure 8. Output Characteristics

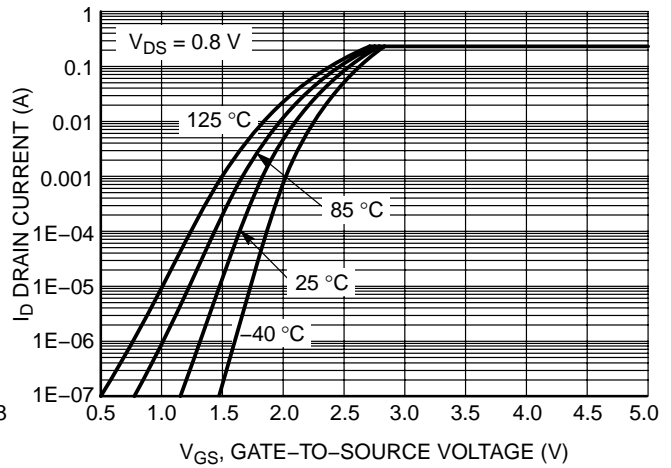
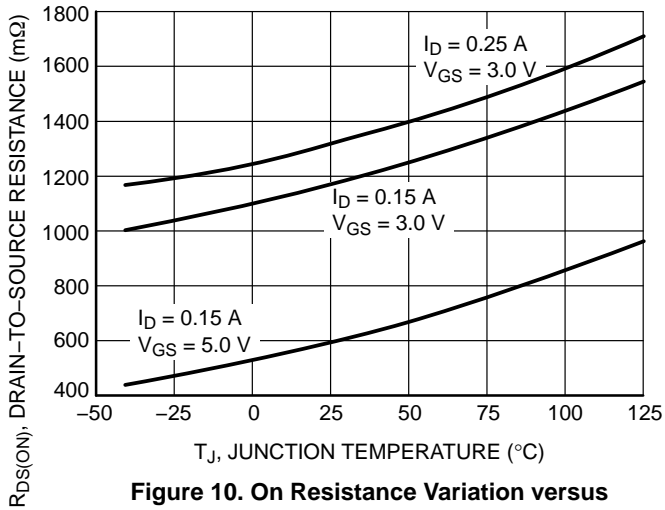
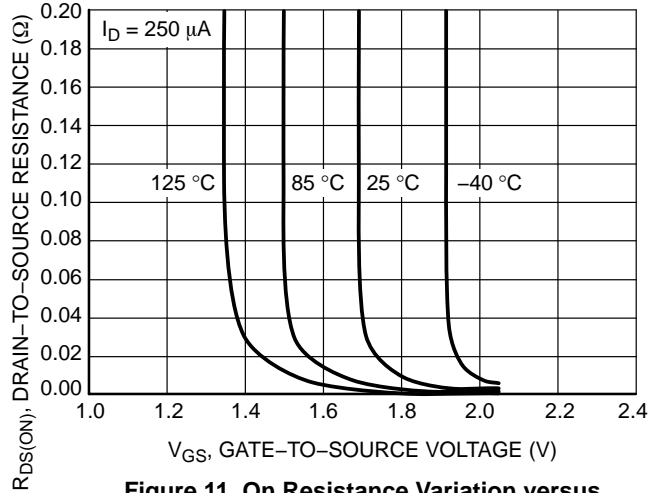

Figure 9. Transfer Function

# NUD3124



**Figure 10. On Resistance Variation versus Junction Temperature**



**Figure 11. On Resistance Variation versus Gate-to-Source Voltage**

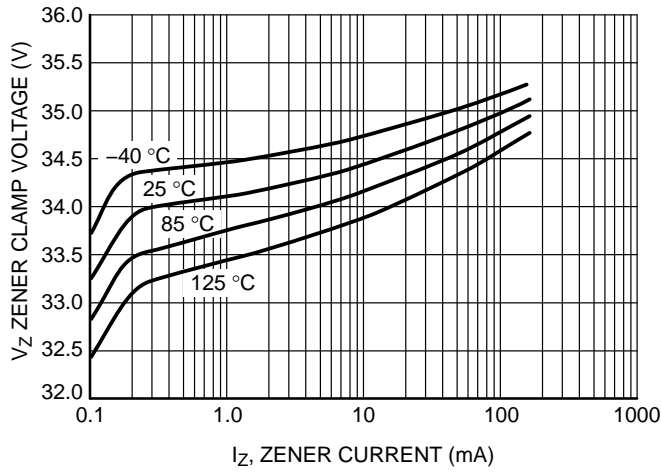

**Figure 12. Zener Clamp Voltage versus Zener Current**

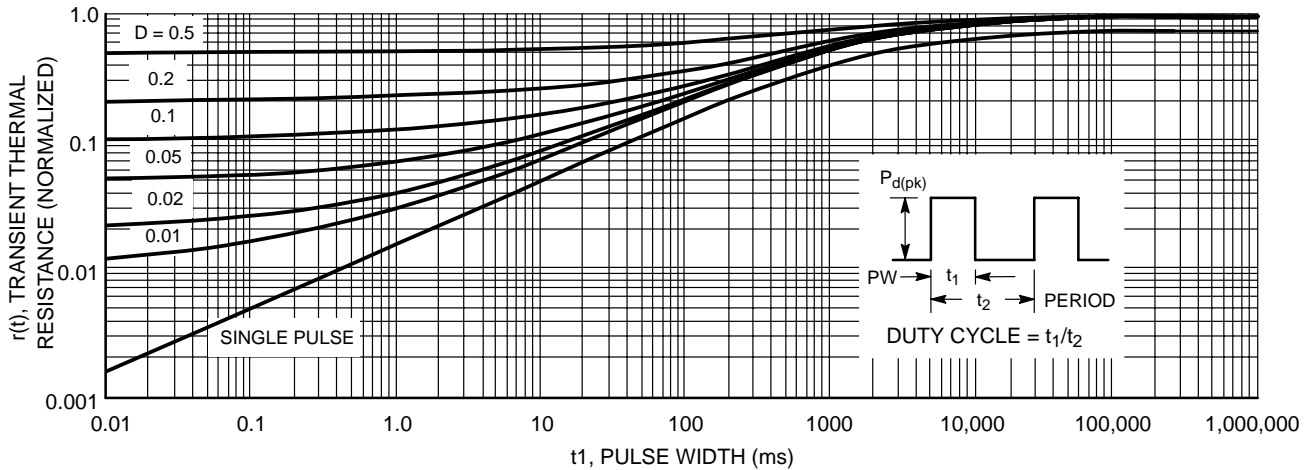

**Figure 13. Transient Thermal Response for NUD3124LT1**

# NUD3124

## APPLICATIONS INFORMATION

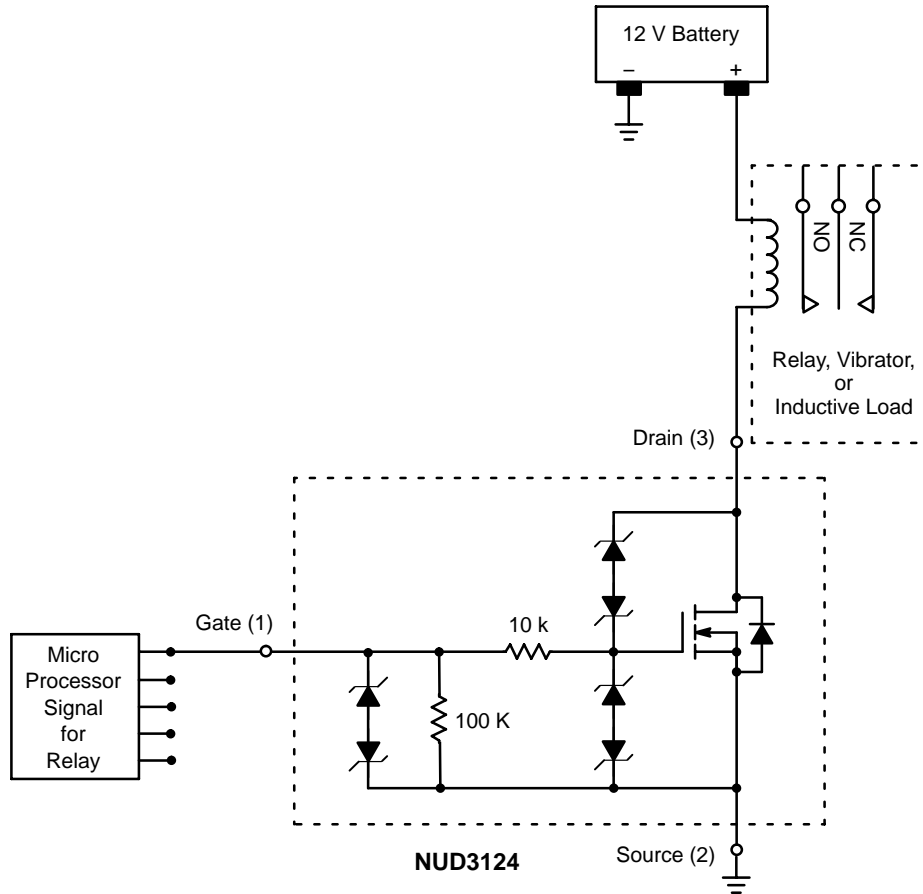
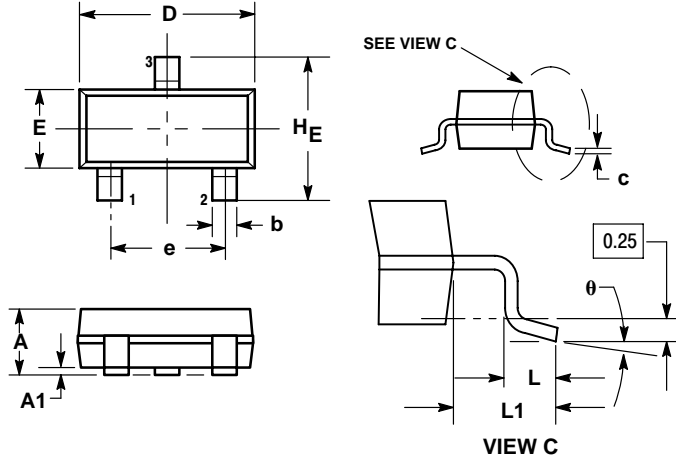

Figure 14. Applications Diagram

# NUD3124

## PACKAGE DIMENSIONS

SOT-23 (TO-236)  
CASE 318-08  
ISSUE AN



NOTES:

1. DIMENSIONING AND TOLERANCING PER ANSI Y14.5M, 1982.
2. CONTROLLING DIMENSION: INCH.
3. MAXIMUM LEAD THICKNESS INCLUDES LEAD FINISH THICKNESS. MINIMUM LEAD THICKNESS IS THE MINIMUM THICKNESS OF BASE MATERIAL.
4. 318-01 THRU -07 AND -09 OBSOLETE, NEW STANDARD 318-08.

DIM	MILLIMETERS			INCHES		
	MIN	NOM	MAX	MIN	NOM	MAX
A	0.89	1.00	1.11	0.035	0.040	0.044
A1	0.01	0.06	0.10	0.001	0.002	0.004
b	0.37	0.44	0.50	0.015	0.018	0.020
c	0.09	0.13	0.18	0.003	0.005	0.007
D	2.80	2.90	3.04	0.110	0.114	0.120
E	1.20	1.30	1.40	0.047	0.051	0.055
e	1.78	1.90	2.04	0.070	0.075	0.081
L	0.10	0.20	0.30	0.004	0.008	0.012
L1	0.35	0.54	0.69	0.014	0.021	0.029
HE	2.10	2.40	2.64	0.083	0.094	0.104

STYLE 21:

1. GATE
2. SOURCE
3. DRAIN

### SOLDERING FOOTPRINT\*

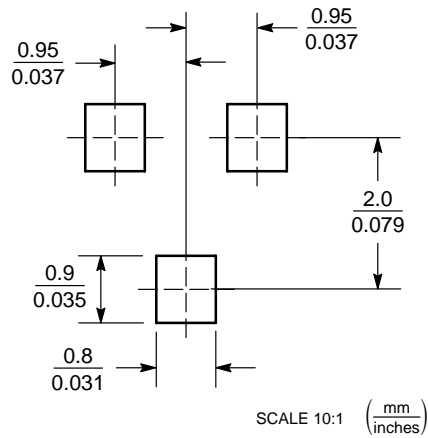

\*For additional information on our Pb-Free strategy and soldering details, please download the ON Semiconductor Soldering and Mounting Techniques Reference Manual, SOLDERRM/D.



# NUD3124

## PACKAGE DIMENSIONS

SC-74  
CASE 318F-05  
ISSUE L

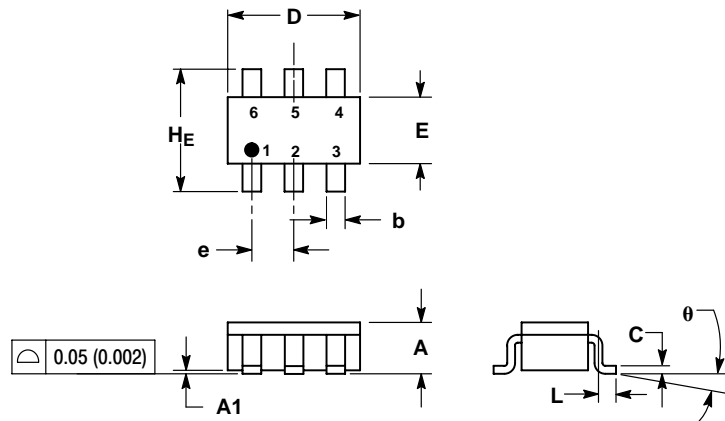

NOTES:

1. DIMENSIONING AND TOLERANCING PER ANSI Y14.5M, 1982.
2. CONTROLLING DIMENSION: INCH.
3. MAXIMUM LEAD THICKNESS INCLUDES LEAD FINISH THICKNESS. MINIMUM LEAD THICKNESS IS THE MINIMUM THICKNESS OF BASE MATERIAL.
4. 318F-01, -02, -03 OBSOLETE. NEW STANDARD 318F-04.

DIM	MILLIMETERS			INCHES		
	MIN	NOM	MAX	MIN	NOM	MAX
A	0.90	1.00	1.10	0.035	0.039	0.043
A1	0.01	0.06	0.10	0.001	0.002	0.004
b	0.25	0.37	0.50	0.010	0.015	0.020
c	0.10	0.18	0.26	0.004	0.007	0.010
D	2.90	3.00	3.10	0.114	0.118	0.122
E	1.30	1.50	1.70	0.051	0.059	0.067
e	0.85	0.95	1.05	0.034	0.037	0.041
L	0.20	0.40	0.60	0.008	0.016	0.024
HE	2.50	2.75	3.00	0.099	0.108	0.118
theta	0°	-	10°	0°	-	10°

STYLE 7:

- PIN 1: SOURCE 1  
2: GATE 1  
3: DRAIN 2  
4: SOURCE 2  
5: GATE 2  
6: DRAIN 1

### SOLDERING FOOTPRINT\*

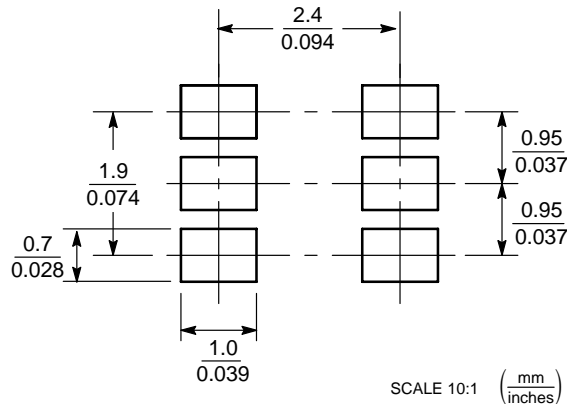

\*For additional information on our Pb-Free strategy and soldering details, please download the ON Semiconductor Soldering and Mounting Techniques Reference Manual, SOLDERRM/D.

MicroIntegration is a trademark of Semiconductor Components Industries, LLC (SCILLC)

ON Semiconductor and are registered trademarks of Semiconductor Components Industries, LLC (SCILLC). SCILLC reserves the right to make changes without further notice to any products herein. SCILLC makes no warranty, representation or guarantee regarding the suitability of its products for any particular purpose, nor does SCILLC assume any liability arising out of the application or use of any product or circuit, and specifically disclaims any and all liability, including without limitation special, consequential or incidental damages. "Typical" parameters which may be provided in SCILLC data sheets and/or specifications can and do vary in different applications and actual performance may vary over time. All operating parameters, including "Typicals" must be validated for each customer application by customer's technical experts. SCILLC does not convey any license under its patent rights nor the rights of others. SCILLC products are not designed, intended, or authorized for use as components in systems intended for surgical implant into the body, or other applications intended to support or sustain life, or for any other application in which the failure of the SCILLC product could create a situation where personal injury or death may occur. Should Buyer purchase or use SCILLC products for any such unintended or unauthorized application, Buyer shall indemnify and hold SCILLC and its officers, employees, subsidiaries, affiliates, and distributors harmless against all claims, costs, damages, and expenses, and reasonable attorney fees arising out of, directly or indirectly, any claim of personal injury or death associated with such unintended or unauthorized use, even if such claim alleges that SCILLC was negligent regarding the design or manufacture of the part. SCILLC is an Equal Opportunity/Affirmative Action Employer. This literature is subject to all applicable copyright laws and is not for resale in any manner.

### PUBLICATION ORDERING INFORMATION

**LITERATURE FULFILLMENT:**  
Literature Distribution Center for ON Semiconductor  
P.O. Box 61312, Phoenix, Arizona 85082-1312 USA  
**Phone:** 480-829-7710 or 800-344-3860 Toll Free USA/Canada  
**Fax:** 480-829-7709 or 800-344-3867 Toll Free USA/Canada  
**Email:** orderlit@onsemi.com

**N. American Technical Support:** 800-282-9855 Toll Free  
USA/Canada

**Japan:** ON Semiconductor, Japan Customer Focus Center  
2-9-1 Kamimeguro, Meguro-ku, Tokyo, Japan 153-0051  
**Phone:** 81-3-5773-3850

**ON Semiconductor Website:** <http://onsemi.com>

**Order Literature:** <http://www.onsemi.com/litorder>

For additional information, please contact your local Sales Representative.

NUD3124/D