

STRUCTURE Silicon Monolithic Integrated Circuit
 PRODUCT SERIES 1ch. Reversible Motor Driver
 TYPE **BD6736FV**
 FEATURES · Full-ON type 1ch. H-bridge Driver

●Absolute maximum ratings (Ta=25°C)

Parameter	Symbol	Limit	Unit
Power supply voltage	VCC	-0.5 to +10.0	V
Motor power supply voltage	VM	-0.5 to +10.0	V
Charge pump step-up power supply voltage	VBST	-0.5 to +15.0	V
Control input voltage	VIN	-0.5 to VCC+0.5	V
Power dissipation	Pd	930 ^{*1}	mW
Operating temperature range	Topr	-30 to +75	°C
Junction temperature	Tjmax	150	°C
Storage temperature range	Tstg	-55 to +150	°C
H-bridge output current DC	Iout	-1000 to +1000 ^{**2}	mA
H-bridge output current (100msec)	Iopeak	-3200 to +3200 ^{**2}	mA

^{*1} Reduced by 7.44mW/°C over 25°C, when mounted on a glass epoxy board (70mm × 70mm × 1.6mm)

^{**2} Must not exceed Pd, ASO, or Tjmax of 150°C.

●Operating Conditions (Ta= -30°C to +75°C)

Parameter	Symbol	Min.	Typ.	Max.	Unit
Power supply voltage	VCC	2.0	5.0	9.0	V
Motor power supply voltage	VM	2.0	5.0	9.0	V
Control input voltage	VIN	0	-	VCC	V
Logic input frequency	FIN	0	-	100	kHz
Min. logic pulse width	TIN	0.5	-	-	µs

The product described in this specification is a strategic product (and/or service) subject to COCOM regulations. It should not be exported without authorization from the appropriate government authorities. This product isn't designed for protection against radioactive rays.

Status of this document: The Japanese version of this document is the formal specification. A customer may use this translation version only for a reference to help reading the formal version. If there are any differences in translation version of this document, formal version takes priority.

●BD6736FV Electrical Characteristics (Unless otherwise specified Ta=25°C, VCC=5.0V, VM=5.0V)

Parameter	Symbol	Limit			Unit	Conditions
		Min.	Typ.	Max.		
Overall						
Circuit current during standby operation	ICCST	-	0	1	μA	PS=0V
Circuit current	ICC	0.5	2.0	4.0	mA	PS=H, FIN=100kHz
Power saving						
High-level input voltage	VPSH	2.0	-	VCC	V	
Low-level input voltage	VPSL	-0.3	-	0.5	V	
High-level input current	IPSH	25	50	100	μA	VPSH=5V
Low-level input current	IPSL	-1	0	1	μA	VPSL=0V
Control input						
High-level input voltage	VINH	2.0	-	VCC	V	
Low-level input voltage	VINL	-0.3	-	0.7	V	
High-level input current	IINH	25	50	100	μA	VINH=5V
Low-level input current	IINL	-1	0	1	μA	VINL=0V
UVLO						
UVLO voltage	VUVLO	1.5	-	1.9	V	
Full-ON Drive block						
Output ON-Resistance	RON	-	0.35	0.5	Ω	Io=±500mA on high and low sides in total

●Package Outline

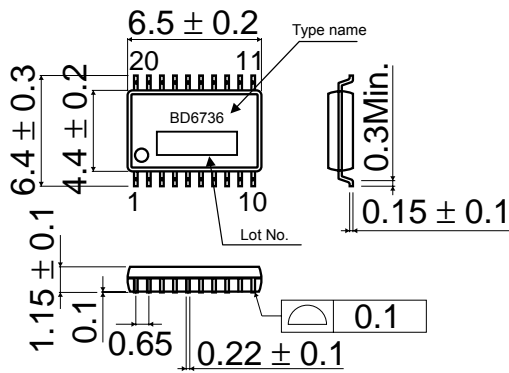

Fig.1 SSOP-B20 Package (Unit: mm)

●Pin Arrangement (Top View)

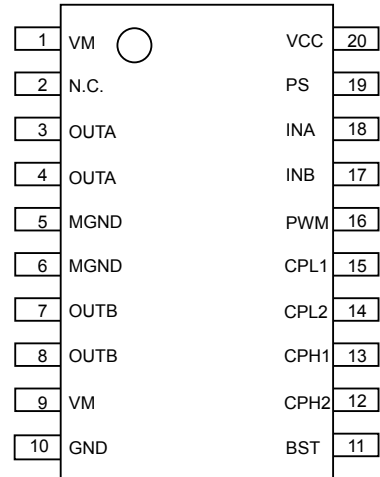

Fig.2 BD6736FV Pin Arrangement (Top View)

●Block Diagram

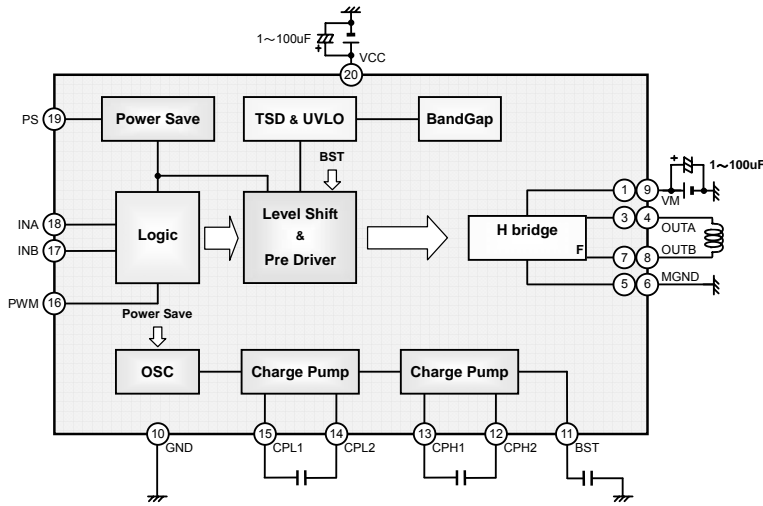

Fig.3 BD6736FV Block Diagram

●Pin No. and Pin Name

No.	Pin ame
1	VM
2	N.C.
3	OUTA
4	OUTA
5	MGND
6	MGND
7	OUTB
8	OUTB
9	VM
10	GND
11	BST
12	CPH2
13	CPH1
14	CPL2
15	CPL1
16	PWM
17	INB
18	INA
19	PS
20	VCC

● I/O Truth Table

BD6736FV I/O Truth Table

Input mode	INPUT				OUTPUT	
	PS	PWM EN	INA	INB	OUTA	OUTB
EN/IN	H	H	L	X	L	L
			H	L	H	L
			H	H	L	H
IN/IN	H	L	L	L	Z	Z
			H	L	H	L
			L	H	L	H
			H	H	L	L
-	L	X	X	X	Z	Z

L: Low, H: High, X: Don't care, Z: High Impedance

● Operation Notes

(1) Absolute maximum ratings

Use of the IC in excess of absolute maximum ratings such as the applied voltage or operating temperature range (Topr) may result in IC damage. Assumptions should not be made regarding the state of the IC (short mode or open mode) when such damage is suffered. The implementation of a physical safety measure such as a fuse should be considered when use of the IC in a special mode where the absolute maximum ratings may be exceeded is anticipated.

(2) Power supply pins and lines

None of the VM line for the H-bridge is internally connected to the VCC power supply line, which is only for the control logic or analog circuit. Therefore, the VM and VCC lines can be driven at different voltages. Although these lines can be connected to a common power supply, do not open the power supply pin but connect it to the power supply externally.

Regenerated current may flow as a result of the motor's back electromotive force. Insert capacitors between the power supply and ground pins to serve as a route for regenerated current. Determine the capacitance in full consideration of all the characteristics of the electrolytic capacitor, because the electrolytic capacitor may lose some capacitance at low temperatures. If the connected power supply does not have sufficient current absorption capacity, regenerative current will cause the voltage on the power supply line to rise, which combined with the product and its peripheral circuitry may exceed the absolute maximum ratings. It is recommended to implement a physical safety measure such as the insertion of a voltage clamp diode between the power supply and ground pins.

For this IC with 2 power supplies and a part consists of the CMOS block, it is possible that rush current may flow instantaneously due to the internal powering sequence and delays, and to the unstable internal logic, respectively. Therefore, give special consideration to power coupling capacitance, width of power and ground wirings, and routing of wiring.

(3) Ground pins and lines

Ensure a minimum GND pin potential in all operating conditions. Make sure that no pins are at a voltage below the GND at any time, regardless of whether it is a transient signal or not.

When using both small signal GND and large current MGND patterns, it is recommended to isolate the two ground patterns, placing a single ground point at the application's reference point so that the pattern wiring resistance and voltage variations caused by large currents do not cause variations in the small signal ground voltage. Be careful not to change the GND wiring pattern of any external components, either.

The power supply and ground lines must be as short and thick as possible to reduce line impedance.

(4) Thermal design

Use a thermal design that allows for a sufficient margin in light of the power dissipation (Pd) in actual operating conditions.

(5) Actions in strong magnetic field

Use caution when using the IC in the presence of a strong magnetic field as doing so may cause the IC to malfunction.

(6) ASO

When using the IC, set the output transistor for the motor so that it does not exceed absolute maximum ratings or ASO.

(7) Thermal shutdown circuit

This IC incorporates a TSD (thermal shutdown) circuit. If the temperature of the chip reaches the following temperature, the motor coil output will be opened. The TSD circuit is designed only to shut the IC off to prevent runaway thermal operation.

It is not designed to protect the IC or guarantee its operation. Do not continue to use the IC after operating this circuit or use the IC in an environment where the operation of this circuit is assumed.

TSD ON temperature [°C] (Typ.)	Hysteresis temperature [°C] (Typ.)
160	20

(8) Application example

The application circuit is recommended for use. Make sure to confirm the adequacy of the characteristics. When using the circuit with changes to the external circuit constants, make sure to leave an adequate margin for external components including static and transitional characteristics as well as dispersion of the IC.

Notes

No copying or reproduction of this document, in part or in whole, is permitted without the consent of ROHM CO.,LTD.

The content specified herein is subject to change for improvement without notice.

The content specified herein is for the purpose of introducing ROHM's products (hereinafter "Products"). If you wish to use any such Product, please be sure to refer to the specifications, which can be obtained from ROHM upon request.

Examples of application circuits, circuit constants and any other information contained herein illustrate the standard usage and operations of the Products. The peripheral conditions must be taken into account when designing circuits for mass production.

Great care was taken in ensuring the accuracy of the information specified in this document. However, should you incur any damage arising from any inaccuracy or misprint of such information, ROHM shall bear no responsibility for such damage.

The technical information specified herein is intended only to show the typical functions of and examples of application circuits for the Products. ROHM does not grant you, explicitly or implicitly, any license to use or exercise intellectual property or other rights held by ROHM and other parties. ROHM shall bear no responsibility whatsoever for any dispute arising from the use of such technical information.

The Products specified in this document are intended to be used with general-use electronic equipment or devices (such as audio visual equipment, office-automation equipment, communication devices, electronic appliances and amusement devices).

The Products are not designed to be radiation tolerant.

While ROHM always makes efforts to enhance the quality and reliability of its Products, a Product may fail or malfunction for a variety of reasons.

Please be sure to implement in your equipment using the Products safety measures to guard against the possibility of physical injury, fire or any other damage caused in the event of the failure of any Product, such as derating, redundancy, fire control and fail-safe designs. ROHM shall bear no responsibility whatsoever for your use of any Product outside of the prescribed scope or not in accordance with the instruction manual.

The Products are not designed or manufactured to be used with any equipment, device or system which requires an extremely high level of reliability the failure or malfunction of which may result in a direct threat to human life or create a risk of human injury (such as a medical instrument, transportation equipment, aerospace machinery, nuclear-reactor controller, fuel-controller or other safety device). ROHM shall bear no responsibility in any way for use of any of the Products for the above special purposes. If a Product is intended to be used for any such special purpose, please contact a ROHM sales representative before purchasing.

If you intend to export or ship overseas any Product or technology specified herein that may be controlled under the Foreign Exchange and the Foreign Trade Law, you will be required to obtain a license or permit under the Law.

Thank you for your accessing to ROHM product informations.

More detail product informations and catalogs are available, please contact your nearest sales office.

ROHM Customer Support System

THE AMERICAS / EUROPE / ASIA / JAPAN

www.rohm.com

Contact us : webmaster@rohm.co.jp