

**DESCRIPTION**

M57159L-01 is a hybrid IC to drive IGBT module. This hybrid IC is driven by two power supplies and provides the required electrical isolation between the input and output with an opto-coupler.

The protection system of this hybrid IC functions with a margin of time by built-in protection circuits to maintain a reverse bias for a predetermined time after the detection of an short-current .

Recommended IGBT modules:  $V_{CES} = 600V/\sim 150A$  class  
 $V_{CES} = 1200V/\sim 75A$  class

**FEATURES**

- Built-in high CMR opto-coupler
- Built-in short-circuit protector (with timer-operated and reset circuit)
- Capability of adjusting time to control short-circuit detection
- Input-output isolation voltage: 2500Vrms for 1min

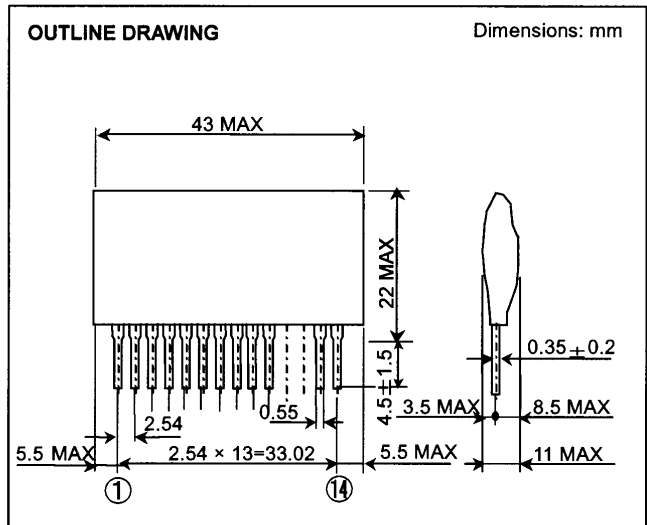

**APPLICATIONS**

To drive IGBT modules for inverter or AC servo systems application.

**BLOCK DIAGRAM**

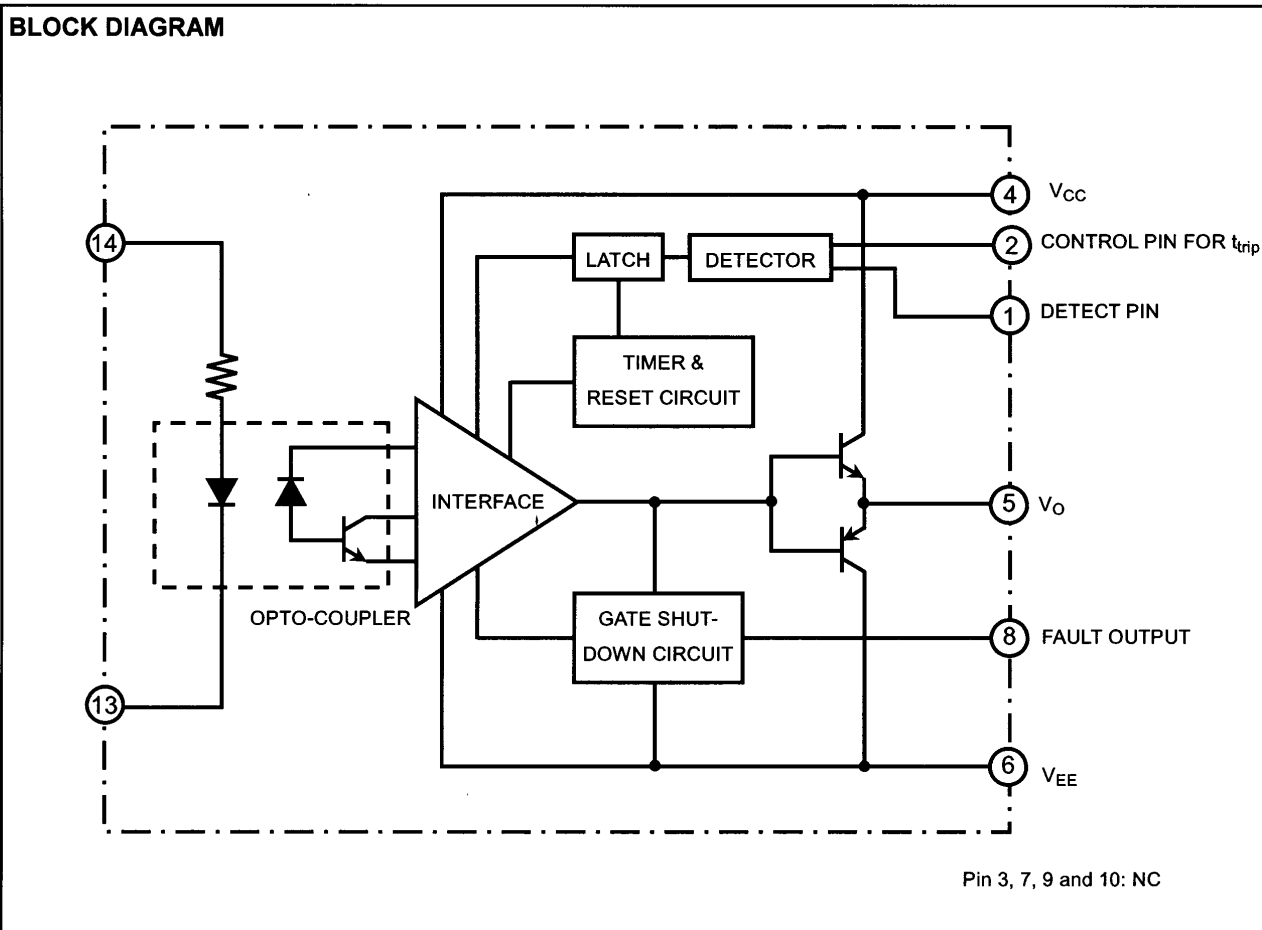

**MAXIMUM RATINGS** (unless otherwise noted,  $T_a=25^\circ\text{C}$ )

Symbol	Parameter	Conditions	Ratings	Unit
$V_{CC}$	Supply voltage	DC	18	V
$V_{EE}$			-12	V
$V_I$	Input voltage	Applied between; 13pin and 14pin	-1 ~ +7	V
$V_O$	Output voltage	When the output voltage is "H"	$V_{CC}$	V
$I_{OHP}$	Output current	Pulse width $2\mu\text{s}$ , $f \leq 20\text{kHz}$	-1.5	A
$I_{OLP}$			1.5	A
$V_{iso}$	Isolation voltage	Sine wave voltage 60Hz, for 1min.	2500	Vrms
$T_C$	Case temperature		85	$^\circ\text{C}$
$T_{opr}$	Operating temperature	No condensation allowable	-20 ~ +60	$^\circ\text{C}$
$T_{stg}$	Storage temperature	No condensation allowable	-25 ~ +100	$^\circ\text{C}$
$I_{FO}$	Fault output current	Inflow current at 8pin	20	mA
$V_{R1}$	Input voltage at 1pin		50	V

**ELECTRICAL CHARACTERISTICS** (unless otherwise noted,  $T_a=25^\circ\text{C}$ ,  $V_{CC} = 15\text{V}$ ,  $V_{EE} = -10\text{V}$ )

Symbol	Parameter	Conditions	Limits			Unit
			Min	Typ	Max	
$V_{CC}$	Supply voltage	Recommended range	14	15	—	V
$V_{EE}$			-7	—	-10	V
$V_{IN}$	Pull-up voltage on primary side	Recommended range	4.75	5	5.25	V
$I_{IH}$	"H" input current	Recommended range	15.2	16	19	mA
f	Switching frequency	Recommended range	—	—	20	KHZ
$R_G$	Gate resistance	Recommended range	4.2	—	—	.
$I_{IH}$	"H" input current	$V_{IN} = 5\text{V}$	—	16	—	mA
$V_{OH}$	"H" output voltage	—	13	14	—	V
$V_{OL}$	"L" output voltage	—	-8	-9	—	V
$t_{PLH}$	"L-H" propagation time	$I_{IH} = 16\text{mA}$	—	0.7	1.3	$\mu\text{s}$
$t_r$	"L-H" rise time	$I_{IH} = 16\text{mA}$	—	0.8	1.5	$\mu\text{s}$
$t_{PHL}$	"H-L" propagation time	$I_{IH} = 16\text{mA}$	—	0.7	1.3	$\mu\text{s}$
$t_f$	"H-L" fall time	$I_{IH} = 16\text{mA}$	—	0.3	0.6	$\mu\text{s}$
$t_{timer}$	Timer	From protection operation to cancel (Input sign is "L")	1	—	2	ms
$I_{FO}$	Fault output current	Inflow current at 8pin, $R = 4.7k_\Omega$	—	5	—	mA
$t_{trip1}$	Short-circuit detection controlled time 1	When the output rises, 1pin; Min 15V, 2pin; open	—	2.4	—	$\mu\text{s}$
$t_{trip2}$	Short-circuit detection controlled time 2 (*)	When the output rises, 1pin; Min 15V, 2pin - 4pin; 1000pF	—	2.8	—	$\mu\text{s}$
$V_{SC}$	Short-circuit detection voltage	Collector voltage of the module which detects a short-circuit	15	—	—	V

(\*) The wiring length of the capacitor for changing short-circuit detection controlled time makes less than 5cm of round trip between pins 2 and 4.

**DEFINITION OF CHARACTERISTICS**

## (1) SWITCHING OPERATION

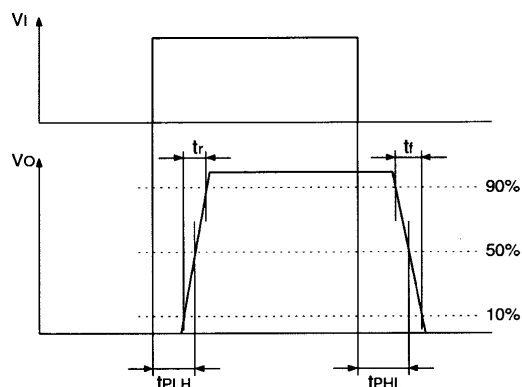

## (2) OPERATION OF SHORT-CIRCUIT

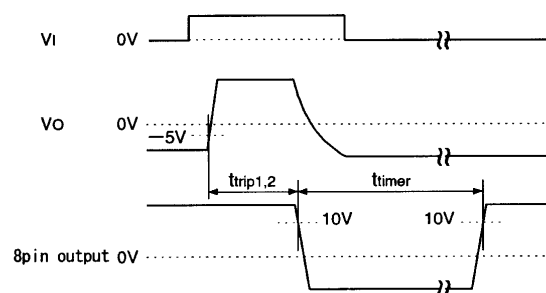

**TYPICAL CHARACTERISTICS**

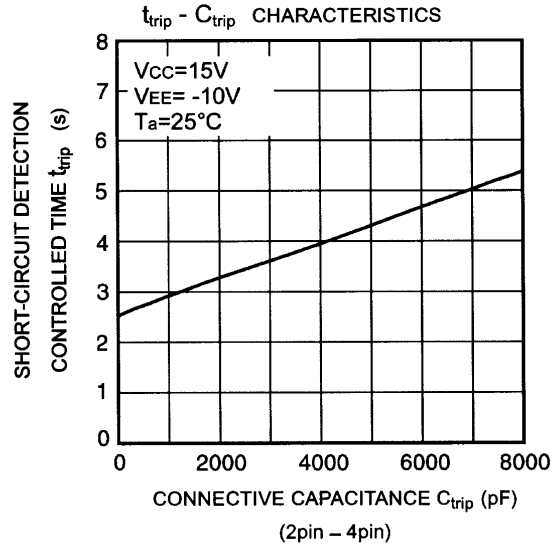
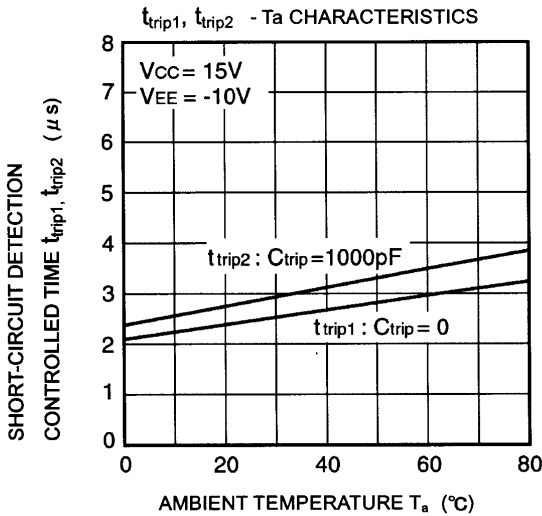
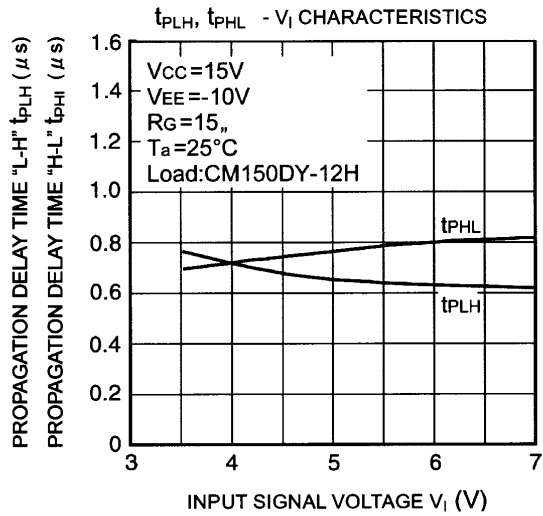
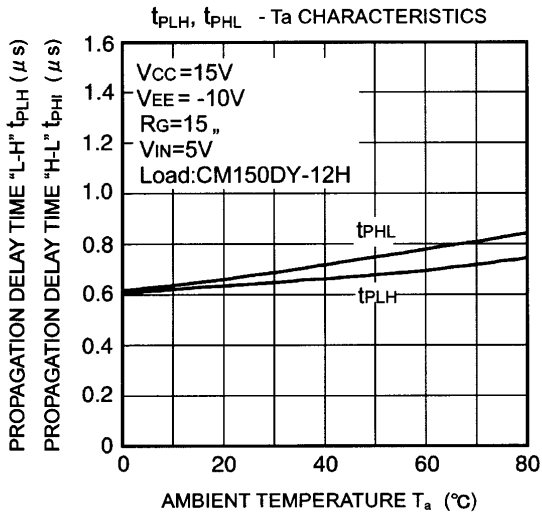

**POWER DISSIPATION - AMBIENT TEMPERATURE  
 (MAXIMUM RATING)**

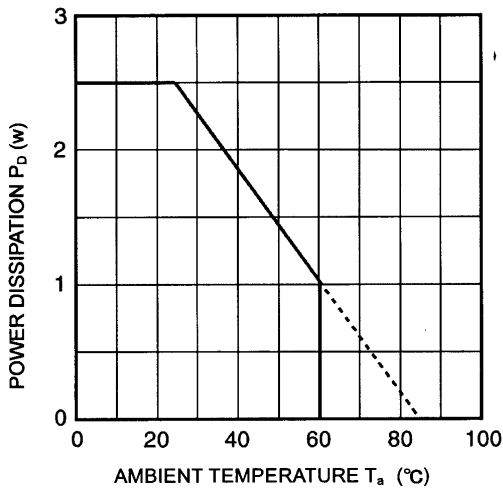

**DISSIPATION CURRENT - SUPPLY VOLTAGE  
 CHARACTERISTICS (4pin - 6pin) INPUT SIGNAL "L"**

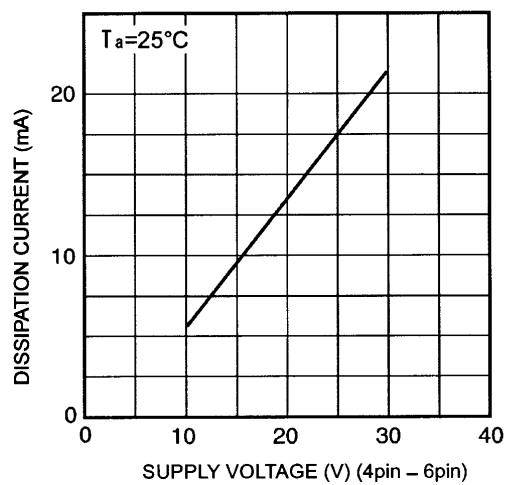

**OPERATION OF PROTECTION CIRCUIT**

- (1) The protection circuit of this hybrid IC is judged to be a sort-circuit state when gate potential is high and collect voltage is high, and gate voltage is dropped immediately. Moreover, the fault sign is output ("L" level) from 8pin to indicate the protection circuit operating simultaneously.
- (2) In about 1 ~ 2ms after this hybrid IC detect of short-circuit, if the input sign is "L", this hybrid IC resets from the short-circuit protection condition and then restart switching operation. ("L" period needs up to 5μs)
- (3) In order to secure ON time of IGBT at the time of the output (5pin) standup, short-circuit detection control time is prepared. (typical: 2.4μs) It can be adjust by connecting capacity between pins 2 and 4.

**OPERATION FLOW OF DETECTING SHORTCIRCUIT**

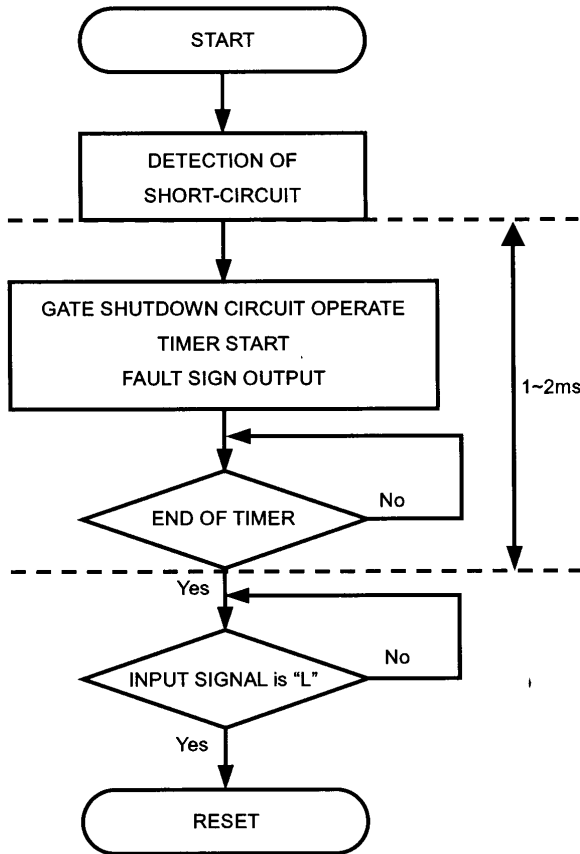

(\*) When the short-circuit protection circuit is operating, the output voltage is about  $-|V_{EE}| + 2V$ .

**APPLICATION CIRCUIT EXAMPLE**

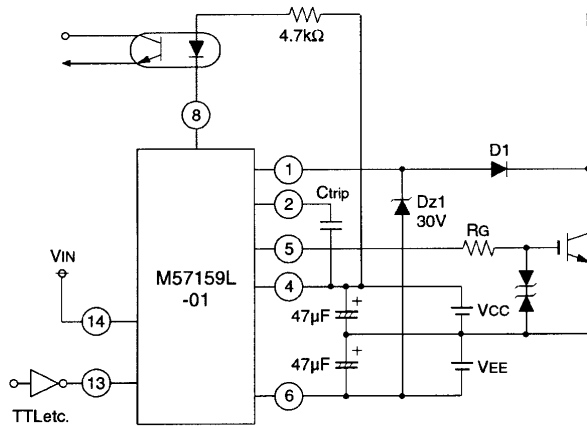

$f = 20\text{kHz}$        $V_{CC} = 15\text{V}$   
 $D.F = 50\%$        $V_{EE} = 10\text{V}$   
 $V_{IN} = 5\text{V}$        $R_G = 15\Omega$   
 $C_{trip} = 0 \sim 3300\text{pF}$   
 D1: First recovery diode ( $t_{rr} \leq 0.2\mu\text{s}$ )

**PRECATION**

- (1) Voltage compensate capacitors are provide as close as possible to this hybrid IC.
- (2) D1 requires the approximately the same voltage of power modules.
- (3) Since very high voltage is impressed to the pin 1 when D1 is reverse-recovered, there is a possibility of destroying an internal element. As mentioned above, the protection measure, such as inserting a Zener diode between pins 1 and 6, is required.
- (4) In case pin 2 is operating, the wiring are expected to be wired as close as possible from pin 2 and pin 4. (Standard length: 5cm and less.)

**APPLICATION EXAMPLE OF SINGLE POWER SUPPLY**

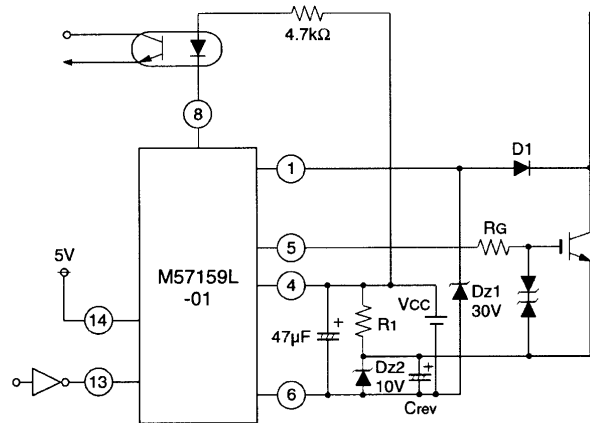

$V_{CC} = 25\text{V}$   
 $C_{rev} = 47\mu\text{F}$   
 $R_1 = 2.7\text{k}\Omega$   
 (\*) Don't input the on sign till the provided ( $R_1 \times C_{rev}(s)$ ) time is passed over after supply turn on.)

**APPLICATION EXAMPLE OF HIGH POWER MODULE**

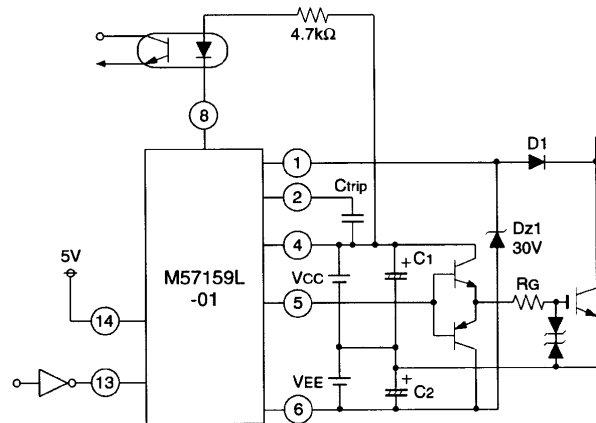

$V_{CC} = 15\text{V}$   
 $V_{EE} = 10\text{V}$   
 $C_{trip} = 1000\text{pF}$   
 $C_1, C_2 \leq 100\mu\text{H}$  (Low impedance)

**FOR SAFETY USING**

Great detail and careful attention are given to the production activity of Hics, such as the development, the quality of production, and in it's reliability. However the reliability of Hics depends not only on their own factors but also in their condition of usage. When handling Hics, please note the following cautions.

CAUTIONS	
Packing	<p>The materials used in packing Hics can only withstand normal external conditions.</p> <p>When exposed to outside shocks, rain and certain environmental contaminators, the packing materials will deteriorates. Please take care in handling.</p>
Carrying	<ol style="list-style-type: none"> <li>1) Don't stack boxes too high. Avoid placing heavy materials on boxes.</li> <li>2) Boxes must be positioned correctly during transportation to avoid breakage.</li> <li>3) Don't throw or drop boxes.</li> <li>4) Keep boxes dry. Avoid rain or snow.</li> <li>5) Minimal vibration and shock during transportation is desirable.</li> </ol>
Storage	<p>When storing Hics, please observe the following notices or possible deterioration of their electrical characteristics, risk of solder ability, and external damage may occur.</p> <ol style="list-style-type: none"> <li>1) Devices must be stored where fluctuation of temperature and humidity is minimal, and must not be exposed to direct sunlight. Store at the normal temperature of 5 to 30 degrees Celsius with humidity at 40 to 60%.</li> <li>2) Avoid locations where corrosive gasses are generated or where much dust accumulates.</li> <li>3) Storage cases must be static proof.</li> <li>4) Avoid putting weight on boxes.</li> </ol>
Extended storage	<p>When extended storage is necessary, Hics must be kept non-processed. When using Hics which have been stored for more than one year or under severe conditions, be sure to check that the exterior is free from flaw and other damages.</p>
Maximum ratings	<p>To prevent any electrical damages, use Hics within the maximum ratings. The temperature, current, voltage, etc. must not exceed these conditions.</p>
Polarity	<p>To protect Hics from destruction and deterioration due to wrong insertion, make sure of polarity in inserting leads into the board holes, conforming to the external view for the terminal arrangement.</p>

**ISAHAYA ELECTRONICS CORPORATION**

Marketing division, Marketing planning department

6-41 Tsukuba, Isahaya, Nagasaki, 854-0065 Japan

**Keep safety first in your circuit designs!**

·ISAHAYA Electronics Corporation puts the maximum effort into making semiconductor products better and more reliable, but there is always the possibility that trouble may occur with them. Trouble with semiconductors may lead to personal injury, fire or property damage. Remember to give due consideration to safety when making your circuit designs, with appropriate measures such as (1) placement of substitutive, auxiliary, (2) use of non-flammable material or (3) prevention against any malfunction or mishap.

**Notes regarding these materials**

- These materials are intended as a reference to our customers in the selection of the ISAHAYA products best suited to the customer's application; they don't convey any license under any intellectual property rights, or any other rights, belonging ISAHAYA or third party.
- ISAHAYA Electronics Corporation assumes no responsibility for any damage, or infringement of any third party's rights, originating in the use of any product data, diagrams, charts or circuit application examples contained in these materials.
- All information contained in these materials, including product data, diagrams and charts, represent information on products at the time of publication of these materials, and are subject to change by ISAHAYA Electronics Corporation without notice due to product improvements or other reasons. It is therefore recommended that customers contact ISAHAYA Electronics Corporation or an authorized ISAHAYA products distributor for the latest product information before purchasing product listed herein.
- ISAHAYA Electronics Corporation products are not designed or manufactured for use in a device or system that is used under circumstances in which human life is potentially at stake. Please contact ISAHAYA electronics corporation or an authorized ISAHAYA products distributor when considering the use of a product contained herein for any specific purposes, such as apparatus or systems for transportation, vehicular, medical, aerospace, nuclear, or undersea repeater use.
- The prior written approval of ISAHAYA Electronics Corporation is necessary to reprint or reproduce in whole or in part these materials.
- If these products or technologies are subject to the Japanese export control restrictions, they must be exported under a license from the Japanese government and cannot be imported into a country other than the approved destination. Any diversion or re-export contrary to the export control laws and regulations of Japan and/or the country of destination is prohibited.
- Please contact ISAHAYA Electronics Corporation or authorized ISAHAYA products distributor for further details on these materials or the products contained therein.