

DESCRIPTION

M57174AL-06B is a hybrid integrated circuit designed for driving n-channel IGBT modules that is able to connect its pins with PCB directly in AC400V system 3-phase inverter. 3 circuits of a high side are isolated between input and output, and the power supplies consist inside. This Hybrid IC can be driven by supply voltage of 2 lines (15V, 5V).

This device has the auxiliary function that cut off each gate signals with inner timer circuit, when "CIN" is turned to "L" voltage by external OC detect circuit.

The low side of an input part has a timing revision circuit that can revise response time with the one of a high side, so this device provides optimal driving for inverters.

Recommended IGBT module: $V_{CES} = 1200V/25A$ class

FEATURES

- Supply voltage.....+5V, +15V
- High side isolation voltage.....2500Vrms, for 1 min
- By pulse transformer drive of a high side, noise immunity is strengthened.
- The power supply for a high side gate drive and the electrolysis capacitor for voltage compensation are unnecessary.
- Space is saved because of SIL structure and built-in 6 drivers.

APPLICATIONS

Non-isolated inverter home electronics, such as a washing machine, air-conditioner and so on.

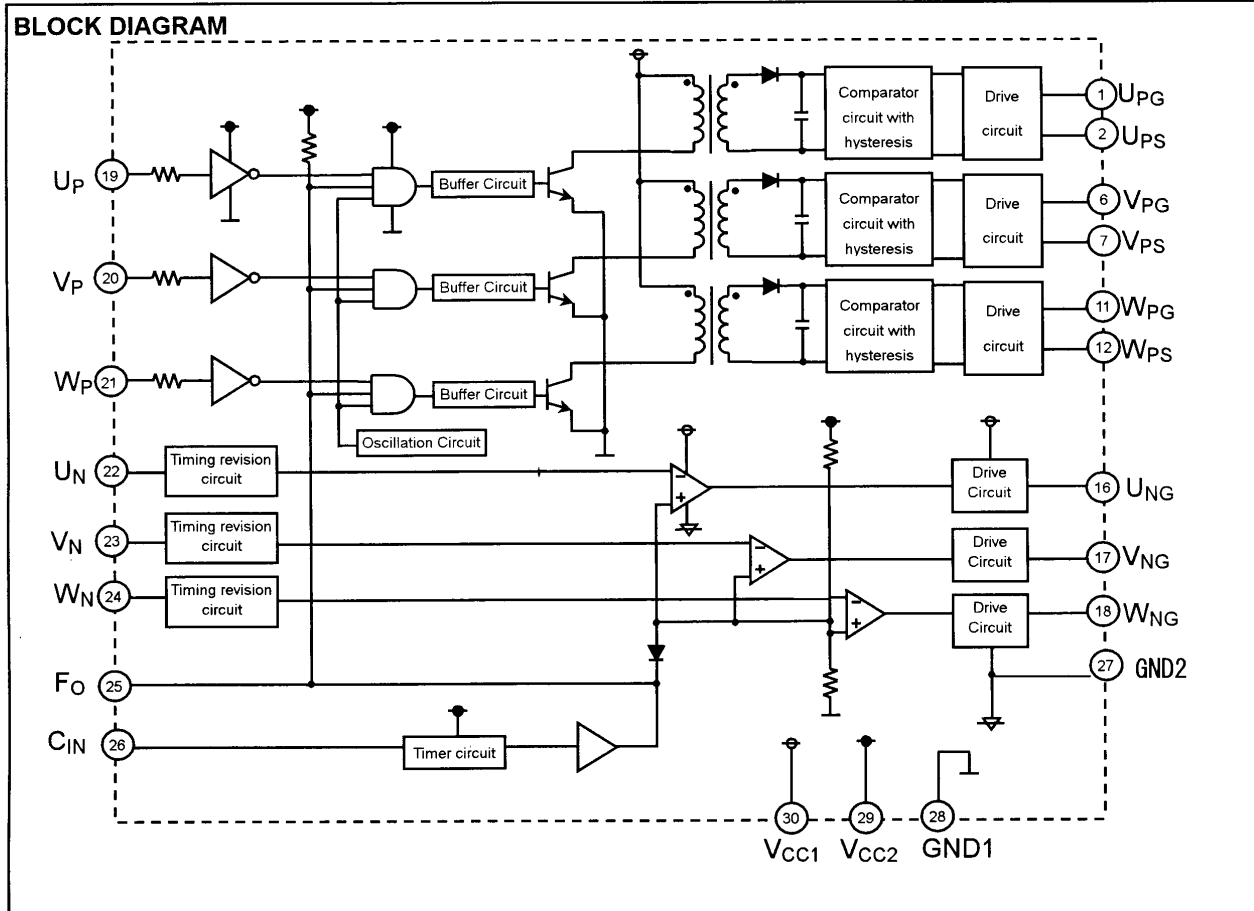
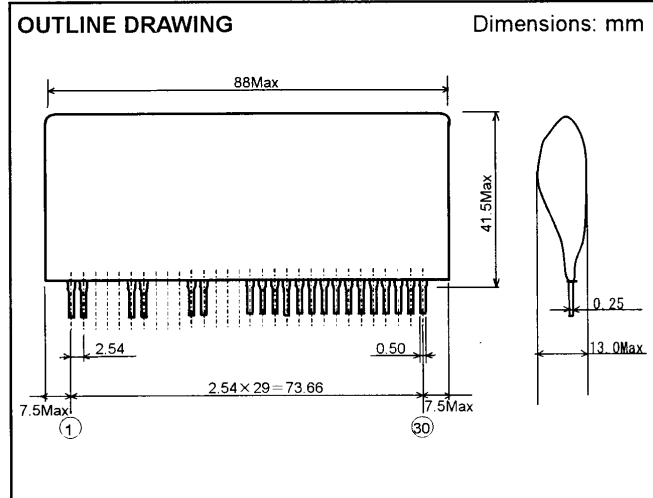

PRELIMINARY

Hybrid IC for driving IGBT modules

MAXIMUM RATINGS (unless otherwise noted, Ta=25°C)

Symbol	Parameter	Conditions	Ratings	Unit
V _{CC1}	Supply voltage 1	DC, between pins 30 and 28	-0.3 ~ 18	V
V _{CC2}	Supply voltage 2	DC, between pins 29 and 28	-0.5 ~ 5.5	V
V _{in} , V _{CIN}	Input/Error signal voltage	Between pins 19, 20, 21, 22, 23, 24, 26 and 28	-0.5 ~ +6	V
V _{iso}	Isolation voltage	AC, 1min, R.H.<50%, High side	2500	V _{rms}
T _C	Case temperature	—	95	°C
T _{opr}	Operating temperature	No condensation allowable	-20 ~ +70	°C
T _{stg}	Storage temperature	No condensation allowable	-25 ~ +100	°C

ELECTRICAL CHARACTERISTICS(Unless otherwise noted, Ta=25°C, V_{CC1} = 15.0V, V_{CC2} = 5.0V, f = 20kHz, D.F. = 50%, CL = 0.01μF)

Symbol	Parameter	Conditions	Limits			Unit
			Min	Typ	Max	
V _{CC1}	Supply voltage 1	Recommended range	14.5	15.0	17.0	V
V _{CC2}	Supply voltage 2	Recommended range	4.75	5.0	5.25	V
f	Switching frequency	Recommended range	—	—	20	kHz
t _{dead}	Dead time	Recommended range for CM25MD-24H	4.0	—	—	μs
V _{IHp}	"H" level input threshold voltage	High side	1.25	1.83	2.2	V
V _{ILp}	"L" level input threshold voltage	High side	2.53	3.0	3.5	V
V _{IN}	N side input threshold voltage	Low side	3.35	3.56	3.75	V
V _{OH}	"H" output voltage	V _{in} : "L" and F _O : "H", I _O = 0A	13.5	14.7	18	V
V _{OL}	"L" output voltage	V _{in} : "H" or F _O : "L", I _O = 0A	—	0.6	1.4	V
I _{OH}	Load short-circuit current: output "H"	P _W < 10μs	—	—	300	mA
I _{OL}	Load short-circuit current: output "L"	P _W < 10μs	—	—	600	mA
t _{PLHp}	"L-H" propagation time: high side (*1)	V _{in} : "L" and F _O : "H", output open	0.6 ^(*2)	1.5	—	μs
t _{PHLp}	"H-L" propagation time: high side (*1)	V _{in} : "H" or F _O : "L", output open	—	1.6	2.4 ^(*2)	μs
t _{rp}	"L-H" rise time: high side	V _{in} : "L" and F _O : "H"	2.4	3.6	—	μs
t _{fp}	"H-L" fall time: high side	V _{in} : "H" or F _O : "L"	—	1.0	1.4	μs
t _{PLHn}	"L-H" propagation time: low side	V _{in} : "L" and F _O : "H", output open	0.5	0.8	—	μs
t _{PHLn}	"H-L" propagation time: low side	V _{in} : "H" or F _O : "L", output open	—	1.0	1.4	μs
t _{rn}	"L-H" rise time: low side	V _{in} : "L" and F _O : "H"	1.8	2.4	—	μs
t _{fn}	"H-L" fall time: low side	V _{in} : "H" or F _O : "L"	—	0.5	0.8	μs
t _p	Minimum off-pulse width	—	4.0	—	—	μs
RG(on)	Inside gate resistor 1	turn-on, "H" output	—	122	—	Ω
RG(off)	Inside gate resistor 2	turn-off, "L" output	—	22	—	Ω
V _{FOH}	"H" level F _O output voltage	Normal mode	—	—	V _{CC2}	V
V _{FOL}	"L" level F _O output voltage	Short-circuit protection operation mode	—	0.2	0.8	V
t _d	Preparation time of Timer operation	Voltage of pin 26 : V _{CIN} ≤ 0.5V (*3)	—	3.0	5.1	μs
t _{timer}	Timer	The "L" period at F _O , t _d ≥ 6.5 μs	70	—	—	μs

(*1) Depending on the timing of input signal and internal oscillation circuit, the propagation time changes in the extent of +/-0.4μs.

(*2) t_{PLHp}=0.6μs at minimum limit and t_{PHLp}=2.4μs at maximum limit: These are contained the changing value 0.4μs by timing of (*1), so each center value is t_{PLHp}=1.0μs at minimum limit and t_{PHLp}=2.0μs at maximum limit.(*3) The maximum value of " t_d + t_{PHLn}" is 6.5μs, which is the period until low side gates is shut down after "CIN" is turned to 0.5V or less.

DEFINITION OF CHARACTERISTICS

(1) Normal switching mode

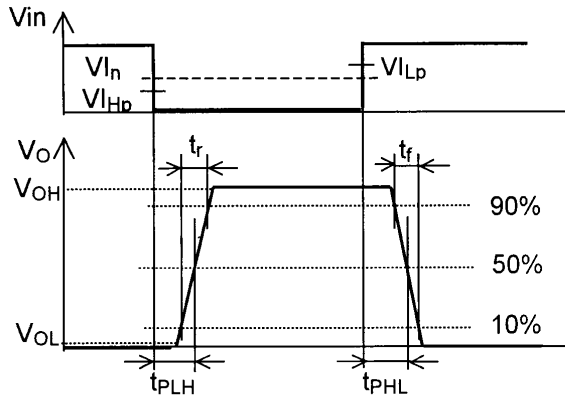

(2) Protection operation mode

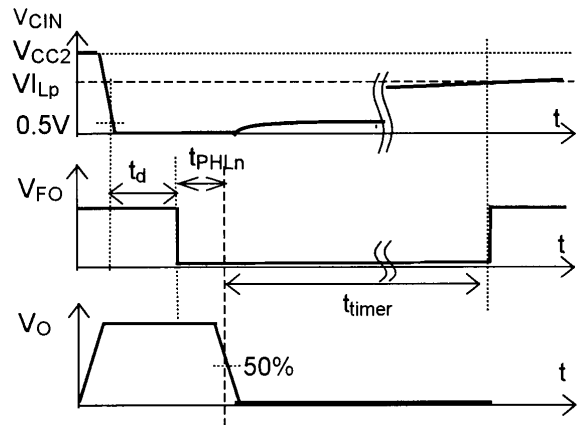

APPLICATION CIRCUIT

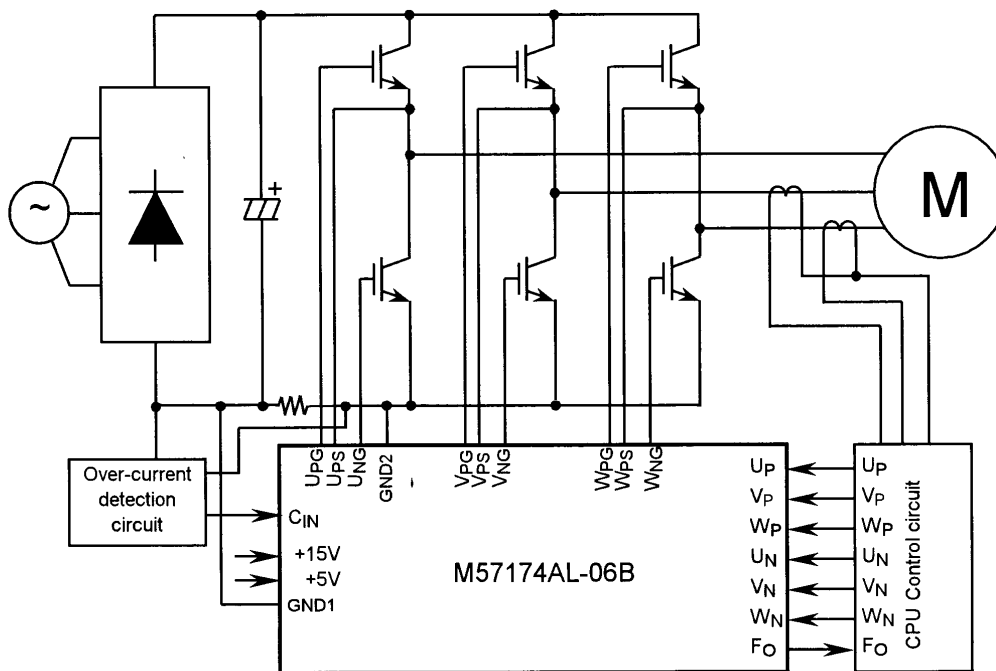

APPLICATION EXAMPLE

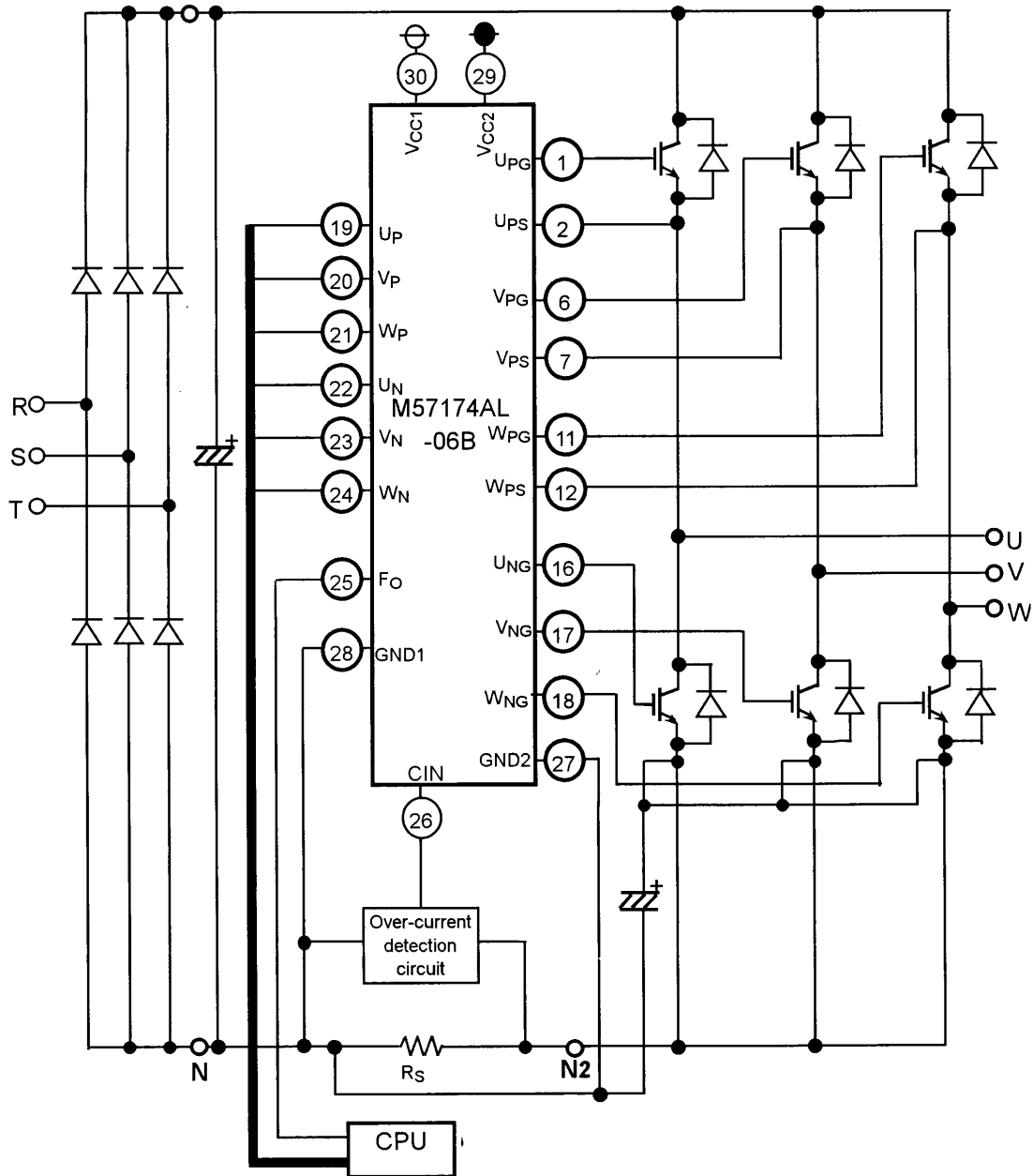

PRELIMINARY

Hybrid IC for driving IGBT modules

PROTECTION OPERATION MODE

This Hybrid IC has the protection operation function, and it works by detecting the both-ends voltage of the current detection resistor (R_s) that is connected between the inverter and converter. (Refer to the following figure)

In the following figure, this Hybrid IC keeps the all gate output " V_{OL} " for fixed time (timer) when unusual. The comparator detects the voltage generated by unusual current that flows resistor (R_s), and outputs "L".

In addition, protection operation is started only when unusual output "L" is held for $5.1\mu s$ (max: Preparation time of Timer operation), and there is delay of $6.5\mu s$ (max) until protection operation starts. Moreover, according the current sink capability of a comparator, preparation time of Timer operation may become long. The length of the timer in the protection operation mode changes according to unusual judging time, and timer also becomes long, so that an unusual period is long.

(Cautions) As the comparator for over-current detection, an output circuit selects an open-collector type.
In case of a totem-pole type comparator, a timer circuit becomes invalid.

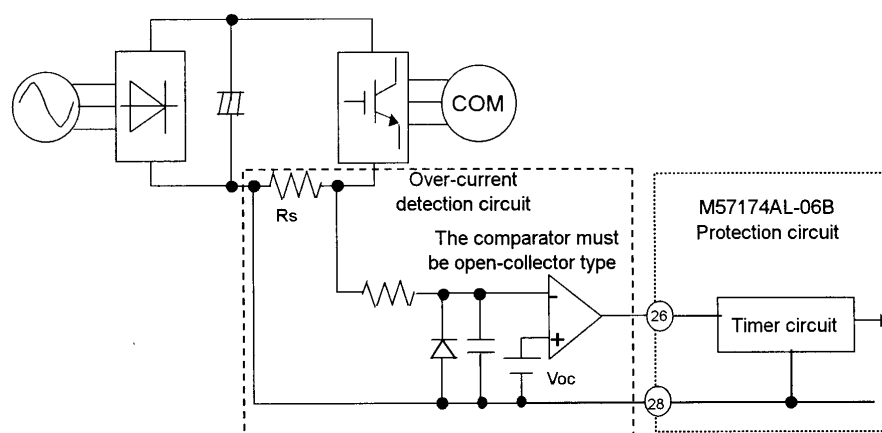

An example of an external circuit detecting over-current

PRELIMINARY

Hybrid IC for driving IGBT modules

FOR SAFETY USING

Great detail and careful attention are given to the production activity of Hics, such as the development, the quality of production, and in its reliability. However the reliability of Hics depends not only on their own factors but also in their condition of usage. When handling Hics, please note the following cautions.

CAUTIONS	
Packing	<p>The materials used in packing Hics can only withstand normal external conditions. When exposed to outside shocks, rain and certain environmental contaminators, the packing materials will deteriorates. Please take care in handling.</p>
Carrying	<ol style="list-style-type: none"> 1) Don't stack boxes too high. Avoid placing heavy materials on boxes. 2) Boxes must be positioned correctly during transportation to avoid breakage. 3) Don't throw or drop boxes. 4) Keep boxes dry. Avoid rain or snow. 5) Minimal vibration and shock during transportation is desirable.
Storage	<p>When storing Hics, please observe the following notices or possible deterioration of their electrical characteristics, risk of solderability, and external damage may occur.</p> <ol style="list-style-type: none"> 1) Devices must be stored where fluctuation of temperature and humidity is minimal, and must not be exposed to direct sunlight. Store at the normal temperature of 5 to 30 degrees Celsius with humidity at 40 to 60%. 2) Avoid locations where corrosive gasses are generated or where much dust accumulates. 3) Storage cases must be static proof. 4) Avoid putting weight on boxes.
Extended storage	<p>When extended storage is necessary, Hics must be kept non-processed. When using Hics which have been stored for more than one year or under severe conditions, be sure to check that the exterior is free from flaw and other damages.</p>
Maximum ratings	<p>To prevent any electrical damages, use Hics within the maximum ratings. The temperaqtue, current, voltage, etc. must not exceed these conditions.</p>
Polarity	<p>To protect Hics from destruction and deterioration due to wrong insertion, make sure of polarity in inserting leads into the board holes, conforming to the external view for the terminal arrangement.</p>

ISAHAYA ELECTRONICS CORPORATION

Marketing division, Marketing planning department

6-41 Tsukuba, Isahaya, Nagasaki, 854-0065 Japan

Keep safety first in your circuit designs!

- ISAHAYA Electronics Corporation puts the maximum effort into making semiconductor products better and more reliable, but there is always the possibility that trouble may occur with them. Trouble with semiconductors may lead to personal injury, fire or property damage. Remember to give due consideration to safety when making your circuit designs, with appropriate measures such as (1) placement of substitutive, auxiliary, (2) use of non-flammable material or (3) prevention against any malfunction or mishap.

Notes regarding these materials

- These materials are intended as a reference to our customers in the selection of the ISAHAYA products best suited to the customer's application; they don't convey any license, under any intellectual property rights, or any other rights, belonging ISAHAYA or third party.
- ISAHAYA Electronics Corporation assumes no responsibility for any damage, or infringement of any third party's rights, originating in the use of any product data, diagrams, charts or circuit application examples contained in these materials
- All information contained in these materials, including product data, diagrams and charts, represent information on products at the time of publication of these materials, and are subject to change by ISAHAYA Electronics Corporation without notice due to product improvements or other reasons. It is therefore recommended that customers contact ISAHAYA Electronics Corporation or an authorized ISAHAYA products distributor for the latest product information before purchasing product listed herein.
- ISAHAYA Electronics Corporation products are not designed or manufactured for use in a device or system that is used under circumstances in which human life is potentially at stake. Please contact ISAHAYA electronics corporation or an authorized ISAHAYA products distributor when considering the use of a product contained herein for any specific purposes, such as apparatus or systems for transportation, vehicular, medical, aerospace, nuclear, or undersea repeater use.
- The prior written approval of ISAHAYA Electronics Corporation is necessary to reprint or reproduce in whole or in part these materials.
- If these products or technologies are subject to the Japanese export control restrictions, they must be exported under a license from the Japanese government and cannot be imported into a country other than the approved destination. Any diversion or reexport contrary to the export control laws and regulations of Japan and/or the country of destination is prohibited.
- Please contact ISAHAYA Electronics Corporation or an authorized ISAHAYA products distributor for further details on these materials or the products contained therein.