

M57916L

HYBRID IC FOR DRIVING TRANSISTOR MODULES

DESCRIPTION

M57916L is a Hybrid Integrated Circuit designed for driving Transistor Modules QM10XX, QM20XX, etc., in an Inverter application. This device operates as an isolation amplifier for Transistor Modules due to the electrical isolation between the input and output, and includes two independent circuits.

FEATURES

- Two independent circuits are included.
Isolation voltage: $V_{iso}=2500V_{rms}$
- Each circuit can be driven by single power supply (7 ~ 9V)

APPLICATION

To drive Transistor Modules for Inverter applications

OUTLINE DRAWING

Dimensions in mm

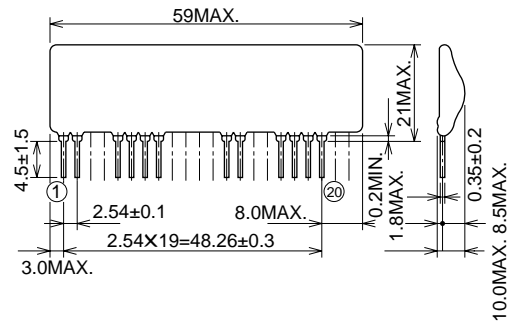

BLOCK DIAGRAM

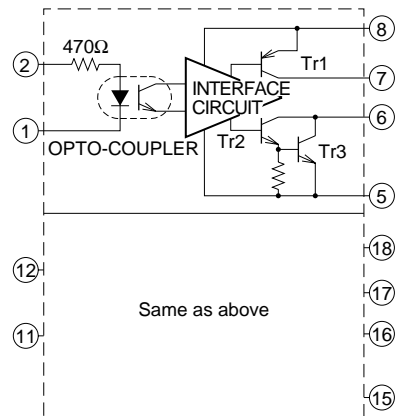

CIRCUIT DIAGRAM

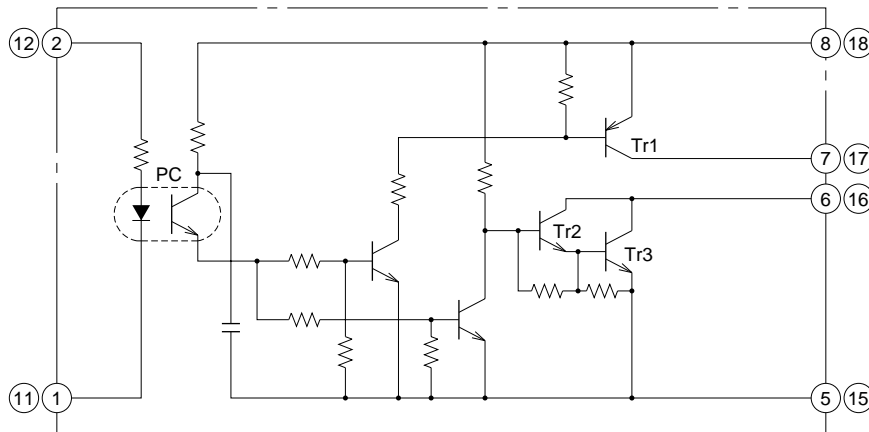

ABSOLUTE MAXIMUM RATINGS ($T_a = -20 \sim +70^\circ\text{C}$, unless otherwise noted)

Symbol	Parameter	Conditions	Ratings	Unit
VCC	Supply voltage	DC	14	V
VI	Input voltage	Between terminals ① and ②	-1 ~ 7	V
IOH	Output current		-1	A
IOLP		Pulse width 10 μ s, Freq. 2kHz, peak value	3	A
Viso	Isolation voltage between two currents	Sinewave voltage 60Hz/min. $T_a = 25^\circ\text{C}$	2500	Vrms
Tj	Junction temperature		100	$^\circ\text{C}$
T _{opg}	Operating temperature		-20 ~ +70	$^\circ\text{C}$
T _{stg}	Storage temperature		-25 ~ +100	$^\circ\text{C}$

ELECTRICAL CHARACTERISTICS ($T_a = 25^\circ\text{C}$, $V_{CC} = 8\text{V}$, unless otherwise noted)

Symbol	Parameter	Test conditions	Limits			Unit
			Min.	Typ.	Max.	
I _{IH}	"H" input current	$V_I = 5\text{V}$	-	7	-	mA
IOH	"H" output current	$R_{ext} = 7\Omega$	-	-0.5	-	A
IOLP	"L" output peak current	$C_{ext} = 47\mu\text{F}$	-	1	-	A
PD	Internal power dissipation	$I_{OH} = -0.5\text{A}$, $I_{OLP} = 1\text{A}$, $f = 2\text{kHz}$, D.F. = 50%	-	1.25	-	W
t _{PLH}	"L-H" propagation delay time	$V_I = 0 \rightarrow 4\text{V}$, $T_j = 100^\circ\text{C}$	-	5	10	μs
t _{PHL}	"H-L" propagation delay time	$V_I = 5 \rightarrow 0\text{V}$, $T_j = 100^\circ\text{C}$	-	8	15	μs

PERFORMANCE CURVES

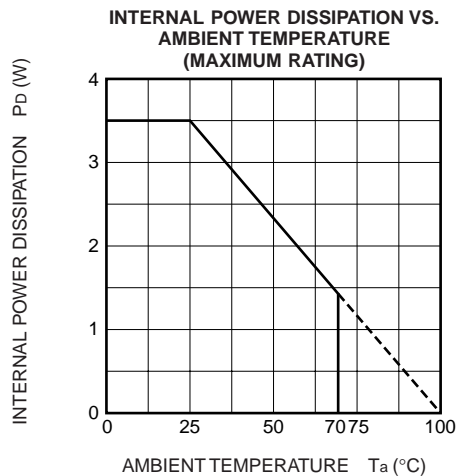
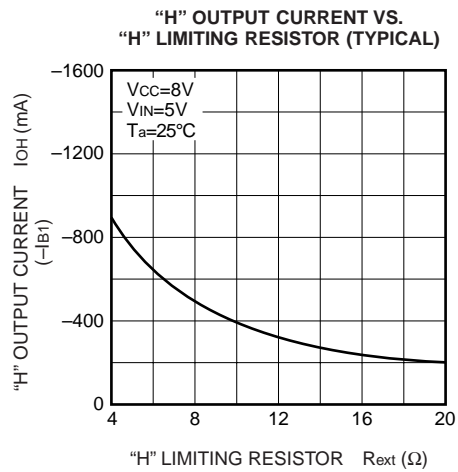
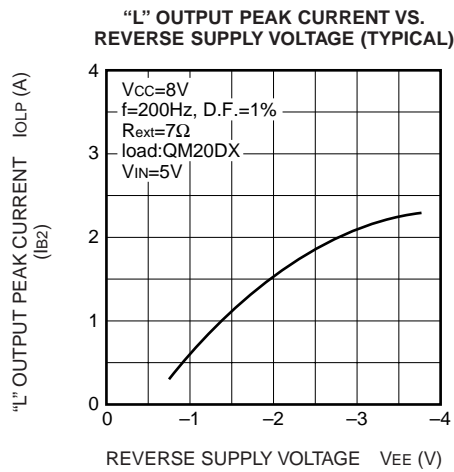
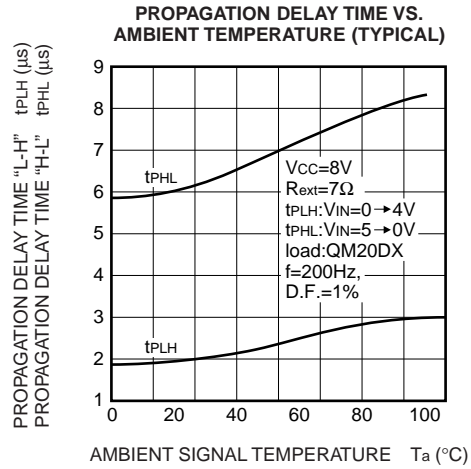
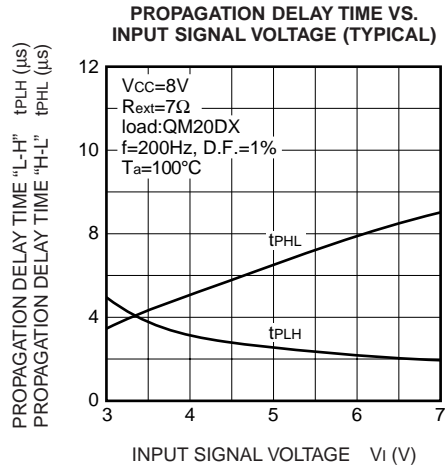

TEST CIRCUIT AND APPLICATION CIRCUIT EXAMPLE

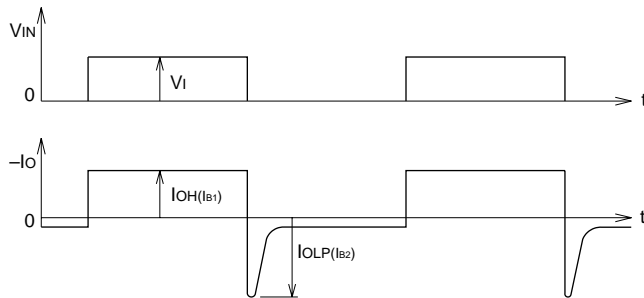
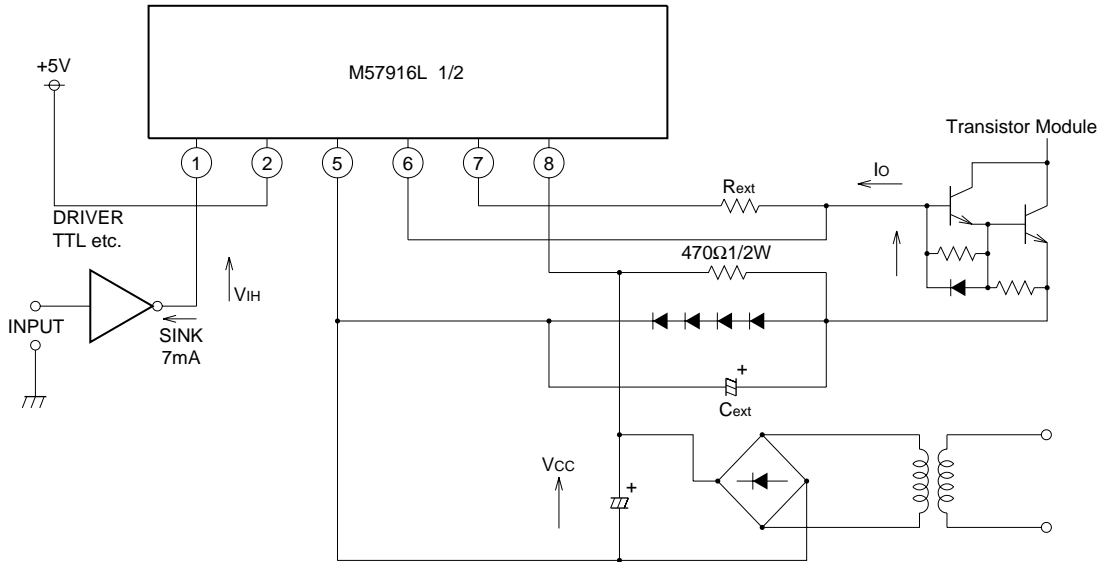

Note: IOH and IOLP correspond to base forward current IB1 and base reverse current IB2 of the transistor module to be driven respectively.