



### 600KHZ PWM/PFM STEP-DOWN DC-DC CONTROLLER

#### DESCRIPTION

The UTC **UC3750** is a high frequency, micropower, voltage mode step-down DC-DC controller IC and is designed for battery operated hand-held electronic products. It can provide up to 2.0A loading current with conversion efficiency by connection of appropriate external P-type MOSFET. It also can be applied to operate for voltage regulation with minimum external components and board space.

The UTC **UC3750** can operate in the constant -frequency PWM (Pulse Width Modulation) mode that provide low output ripple noise in the normal operation and will automatically switch to PFM(Pulse Frequency Modulation) mode at low output loads for higher efficiency. Moreover, it is ideal for portable applications profited from Chip Enable (CE) to reduce IC off-stage current and integrated feedback resistor network.

The UTC **UC3750** is suitable for applications, such as PDA, camcorders and digital still camera, hand-held instrument, distributed power system, computer peripheral, conversion from four NiMH or NiCd or one Lithium-ion cells to 3.3V/1.8V.

#### FEATURES

- \* High efficiency: 92% (Typ.)
- \* Low quiescent bias current :50µA
- \* Low shutdown current:0.3µA (Typ.)
- \* Output voltage:1.8V~3.3V ±2.0%
- \* Low output voltage ripple:50mV (Typ.)
- \* Built-in soft-start (SS)
- \* Pulse Width Modulation (PWM)switching frequency:600kHz
- \* Automatic PWM/PFM switchover under light load condition
- \* Very low dropout operation, 100% max. duty cycle
- \* Chip enable(CE) pin with on-chip 150nA pull-up current source
- \* Input voltage: 2.45V- 5.5V
- \* Internal under-voltage lockout (UVLO) protection
- \* Low profile and minimum external components
- \* Halogen free

#### ORDERING INFORMATION

Ordering Number	Package	Packing
UC3750G-xx-AF5-R	SOT-25	Tape Reel

Note: xx: Output Voltage, refer to Marking Information.

<p>UC3750G-xx-AF5-R</p>	<p>(1) R: Tape Reel</p> <p>(2) AF5: SOT-25</p> <p>(3) xx: Refer to Marking Information</p> <p>(4) G: Halogen Free</p>
-------------------------	---

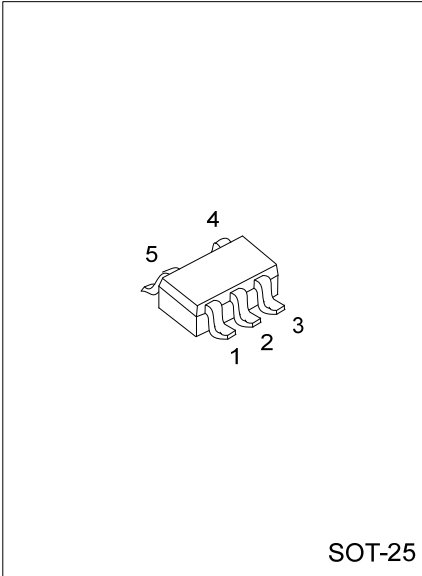

### MARKING INFORMATION

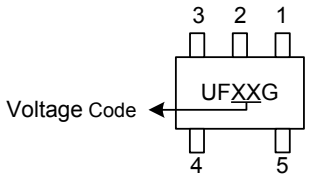
PACKAGE	VOLTAGE CODE	MARKING
SOT-25	27: 2.7V 33: 3.3V	

### PIN CONFIGURATION

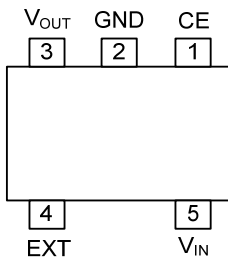

### PIN DESCRIPTION

PIN NO.	PIN NAME	DESCRIPTION
1	CE	Chip Enable pin, active high (internal pull-up current source). By connecting this pin to GND, the switching operation of the controller will be stopped.
2	GND	Ground Connection
3	$V_{OUT}$	Output voltage monitoring input. This pin must be connected to the regulated output node as a feedback to on-chip control circuitry. $V_{OUT}$ is internally connected to the on-chip voltage divider that determines the output voltage level.
4	EXT	Gate drive for external P-MOSFET.
5	$V_{IN}$	Power supply input

■ BLOCK DIAGRAM

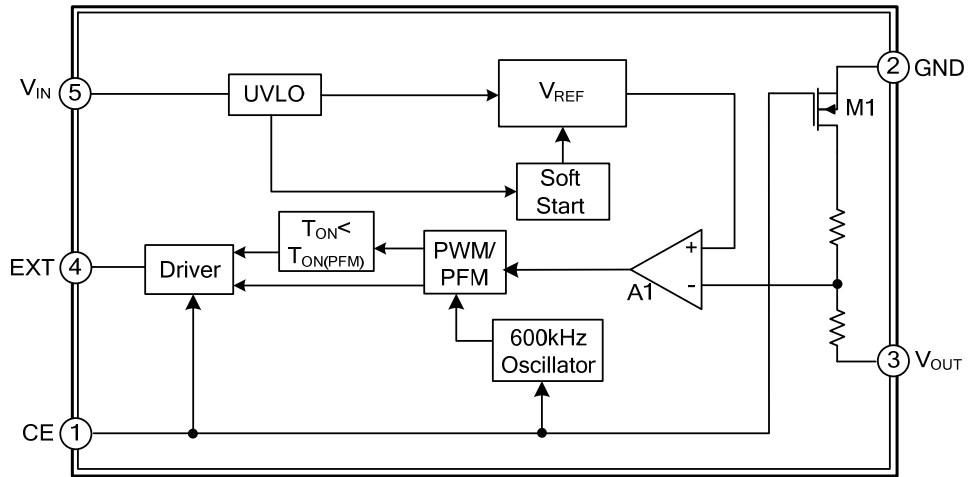

■ ABSOLUTE MAXIMUM RATING (Ta=25°C, unless otherwise specified)

PARAMETER	SYMBOL	RATINGS	UNIT
Device Power Supply	V <sub>IN</sub>	-0.3 ~ 6.0	V
Input Voltage (CE)	V <sub>CE</sub>	-0.3 ~ 6.0	V
Output Voltage (V <sub>OUT</sub> )	V <sub>OUT</sub>	-0.3 ~ 6.0	V
Output Voltage (EXT)	V <sub>EXT</sub>	-0.3 ~ 6.0	V
Junction Temperature	T <sub>J</sub>	+150	°C
Operating Temperature	T <sub>OPR</sub>	-40~+85	°C
Storage Temperature	T <sub>STG</sub>	-55~+150	°C

Note: Absolute maximum ratings are those values beyond which the device could be permanently damaged. Absolute maximum ratings are stress ratings only and functional device operation is not implied.

■ THERMAL DATA

PARAMETER	SYMBOL	MIN	TYP	MAX	UNIT
Junction to Ambient	θ <sub>JA</sub>			250	°C/W

■ ELECTRICAL CHARACTERISTICS

(Ta = 25°C (TYP. value), -40°C ≤ Ta ≤ 85°C (MIN. and MAX. values), unless otherwise specified)

**UC3750-27(2.7V)**

PARAMETER	SYMBOL	TEST CONDITIONS	MIN	TYP	MAX	UNIT
<b>TOTAL DEVICE</b>						
Input Voltage	V <sub>IN</sub>		2.45		5.50	V
Output Voltage	V <sub>OUT</sub>	I <sub>LOAD</sub> = 0mA, Ta = 25°C	2.646	2.7	2.754	V
Input Current into V <sub>OUT</sub> Pin	I <sub>I(VOUT)</sub>			2.5	4.0	μA
Operating Current	I <sub>DD</sub>	V <sub>IN</sub> = 5.0V, V <sub>CE</sub> = 5.0 V (No External Components)		50	80	μA
Off-State Current	I <sub>OFF</sub>	V <sub>IN</sub> = 5.0V, V <sub>CE</sub> = 0V, Ta = 25°C		0.3	0.5	μA
<b>OSCILLATOR</b>						
Frequency	F <sub>OSC</sub>		510	600	690	kHz
Maximum Duty Cycle	D <sub>MAX</sub>		100			%
Switchover ON Time Threshold (Note)	T <sub>ON</sub>		167	320	500	nS
Soft-Start Delay Time (Note)	T <sub>SS</sub>			8.0		mS
Protection Delay Time	T <sub>PORT</sub>	Auto Restart		8.0		mS
<b>OUTPUT DRIVE (EXT PIN)</b>						
EXT "H" Output Current	I <sub>EXTH</sub>	V <sub>EXT</sub> = V <sub>IN</sub> - 0.4V		-60		mA
EXT "L" Output Current	I <sub>EXTL</sub>	V <sub>EXT</sub> = 0.4 V		100		mA
EXT "L-H" Rise Time	T <sub>R</sub>	C <sub>LOAD</sub> = 1000pF, V <sub>IN</sub> = 5.0V		65		nS
EXT "H-L" Fall Time	T <sub>F</sub>	C <sub>LOAD</sub> = 1000pF, V <sub>IN</sub> = 5.0V		40		nS
EXT "L-H" Rise Time	T <sub>R</sub>	C <sub>LOAD</sub> = 5.0nF, V <sub>IN</sub> = 5.0V		140		nS
EXT "H-L" Fall Time	T <sub>F</sub>	C <sub>LOAD</sub> = 5.0nF, V <sub>IN</sub> = 5.0V		90		nS
<b>CE (CE PIN)</b>						
CE "H" Input Voltage	V <sub>CEH</sub>		1.3			V
CE "L" Input Voltage	V <sub>CEL</sub>				0.3	V
CE "H" Input Current	I <sub>CEH</sub>	V <sub>IN</sub> = V <sub>CE</sub> = 5.0V	-0.5	0	0.5	μA
CE "L" Input Current	I <sub>CEL</sub>	V <sub>IN</sub> = 5.0V, V <sub>CE</sub> = 0V	-0.5	0.15	0.5	μA
<b>Under-Voltage Lockout</b>						
Under-Voltage Lockout Threshold	V <sub>UVLO</sub>		1.60	2.20	2.40	V
Under-Voltage Lockout Hysteresis	V <sub>UVLO(HYS)</sub>			50		mV

■ ELECTRICAL CHARACTERISTICS

**UC3750-33(3.3V)**

PARAMETER	SYMBOL	TEST CONDITIONS	MIN	TYP	MAX	UNIT
<b>TOTAL DEVICE</b>						
Input Voltage	$V_{IN}$		2.45	5.0V	5.50	V
Output Voltage	$V_{OUT}$	$I_{LOAD} = 0mA, T_a = 25^\circ C$	3.234	3.3	3.366	V
Input Current into $V_{OUT}$ Pin	$I_{I(VOUT)}$			2.5	4.0	$\mu A$
Operating Current	$I_{DD}$	$V_{IN} = 5.0V, V_{CE} = 5.0V$ (No External Components)		50	80	$\mu A$
Off-State Current	$I_{OFF}$	$V_{IN} = 5.0V, V_{CE} = 0V, T_a = 25^\circ C$		0.3	0.5	$\mu A$
<b>OSCILLATOR</b>						
Frequency	$F_{OSC}$		510	600	690	kHz
Maximum Duty Cycle	$D_{MAX}$		100			%
Switchover ON Time Threshold (Note)	$T_{ON}$		167	320	500	nS
Soft-Start Delay Time (Note)	$T_{SS}$			8.0		mS
Protection Delay Time	$T_{PORT}$	Auto Restart		8.0		mS
<b>OUTPUT DRIVE (EXT)</b>						
EXT "H" Output Current	$I_{EXTH}$	$V_{EXT} = V_{IN} - 0.4V$		-60		mA
EXT "L" Output Current	$I_{EXTL}$	$V_{EXT} = 0.4V$		100		mA
EXT "L-H" Rise Time	$T_R$	$C_{LOAD} = 1000pF, V_{IN} = 5.0V$		65		nS
EXT "H-L" Fall Time	$T_F$	$C_{LOAD} = 1000pF, V_{IN} = 5.0V$		40		nS
EXT "L-H" Rise Time	$T_R$	$C_{LOAD} = 5.0nF, V_{IN} = 5.0V$		140		nS
EXT "H-L" Fall Time	$T_F$	$C_{LOAD} = 5.0nF, V_{IN} = 5.0V$		90		nS
<b>CE (CE)</b>						
CE "H" Input Voltage	$V_{CEH}$		1.3			V
CE "L" Input Voltage	$V_{CEL}$				0.3	V
CE "H" Input Current	$I_{CEH}$	$V_{IN} = V_{CE} = 5.0V$	-0.5	0	0.5	$\mu A$
CE "L" Input Current	$I_{CEL}$	$V_{IN} = 5.0V, V_{CE} = 0V$	-0.5	0.15	0.5	$\mu A$
<b>Under-Voltage Lockout</b>						
Under-Voltage Lockout Threshold	$V_{UVLO}$		1.60	2.20	2.40	V
Under-Voltage Lockout Hysteresis	$V_{UVLO(HYS)}$			50		mV

Notes: 1. PWM/PFM Switchover ON Time Threshold min/max guaranteed by design only.

## ■ DESCRIPTION INFORMATION

### 1. Detailed Operating Description

The UTC **UC3750** is a step-down DC–DC controllers designed specially in portable applications powered by battery cells. The UTC **UC3750** combines the advantages of Pulse frequency modulation (PFM) and Constant-frequency pulse width modulation (PWM) which can provide excellent efficiency with light loads and high efficiency and low output voltage ripple at heavy loads respectively. This device can provide up to 2.0 A loading current with appropriate external P-type MOSFET connected. Because of working at high switching frequency, it's possible to use small size surface mount inductor and capacitors to reduce PCB area and provide better interference handling for noise sensitive applications.

### 2. The Internal Oscillator

The UTC **UC3750** needs an oscillator to govern the switching of a PWM control cycles. The UTC **UC3750** has an internal Fixed– frequency oscillator. The oscillator signal generates all the using timing signals. And the oscillator frequency is set to 600 kHz  $\pm 15\%$ .

### 3. Voltage Reference and Soft-Start

The UTC **UC3750** has a built-in soft-start (SS) circuit that controls the ramping up of the internal reference voltage during the power-up of the converter. This function effectively enables the output voltage rise gradually over the specified soft-start time (8 ms typ.), which prevents the output voltage from overshooting during startup of the converter.

The UTC **UC3750** includes an internal high accuracy voltage reference. This reference voltage is connected to the inverting input terminal of the error amplifier (EA), A1, which compared with portion of the output voltage that is derived from an integrated voltage divider with precise trimming to give the required output voltage with  $\pm 2\%$  accuracy.

### 4. Voltage Mode Pulse width modulation (PWM) Control Scheme

The UTC **UC3750** is working in constant-frequency pulse width modulation (PWM) voltage mode control. The controller operates with the internal oscillator which generates the required ramp function to compare with the output of the error amplifier (EA), A1. The error amplifier (EA) compares the internally divided-down output voltage with the voltage reference to produce an error voltage at its output. This error voltage is compared with the ramp function to generate the control pulse to drive the external power switch. On a cycle-by-cycle basis, the greater the error voltage is greater; the switch is held on longer. Hence, corresponding corrective action will be made to keep the output voltage within regulation. Constant-frequency PWM reduces output voltage ripple and noise, which is one of the important characteristics for noise sensitive communication applications. The high switching frequency allows small size surface mount components to improve layout compactness, reducing PC board area, eliminating audio and emission interference.

### 5. Power-Saving Pulse-Frequency-Modulation (PFM) Control Scheme

The converter enters the discontinuous conduction mode (DCM) operation when the load is decreasing, which means the inductor current will decrease to 0 before the next switching cycle starts. In DCM operation, the ON time for each switching cycle will decrease significantly when the output current decreases. In order to maintain high conversion efficiency even at light load conditions, the ON time for each switching cycle is closely monitored and for any ON time is smaller than the preset value (320 ns), the switching pulse will be skipped. As a result, when the loading current is small, the converter will be operating in a “Constant ON time (320 ns nominal), variable OFF time” Pulse frequency modulation (PFM) mode. This innovative control scheme improves the conversion efficiency for the system at light load and standby operating conditions hence extend the operating life of the battery.

### 6. Low Power Shutdown Mode

Once the CE pin is tied to GND the UTC **UC3750** can't work. In shutdown mode, the internal reference, oscillator, control circuitry, driver and internal feedback voltage divider are turned off and the output voltage falls to 0 V. Because most of the internal circuits can't work and the current paths are cut-off, the device consume rather small in this condition.

### 7. Under-Voltage Lockout (UVLO)

The UTC **UC3750** incorporated the UVLO to prevent operation of the P-channel MOSFET below rated input voltage levels. The comparator will turn-off the control circuitry and shut the converter down, once the input supply voltage drops below about 2.2 V.

## ■ DESCRIPTION INFORMATION(Cont.)

### 8. Inductor Value Calculation

Selecting the proper inductance must take an inductor's physical size, transient respond and power conversion requirements into consideration. The fact is that lower inductor value can make the cost, PC board space smaller and can provide faster transient response while resulting in higher ripple current and core losses. The loading current,  $I_{OUT} = 0.5A$  and the inductor ripple current,  $I_{L-RIPPLE(P-P)}$  is designed to be less than 40% of the load current, i.e.  $0.5A \times 40\% = 0.2A$ . The relationship between the inductor value and inductor ripple current is as followed:

$$L = \frac{T_{ON} \times (V_{IN} - R_{DS(ON)} \times I_{OUT} - V_{OUT})}{I_{L-RIPPLE(P-P)}}$$

Where  $R_{DS(ON)}$  is the ON resistance of the external P-channel MOSFET.

### 9. P-Channel Power MOSFET Selection

The operation of UTC **UC3750** must be used with an external P-Channel power MOSFET. The main keys for the power MOSFET are the gate threshold,  $V_{GS}$ , the "ON" resistance,  $R_{DS(ON)}$  and its total gate charge,  $Q_T$ . Low input voltage operation need a low gate threshold device that can work down to the minimum input voltage level.  $R_{DS(ON)}$  determines the conduction losses for each switching cycle, the lower the ON resistance, the higher and the efficiency can be achieved. A power MOSFET with lower gate charge can give lower switching losses but the fast transient can cause unwanted EMI to the system. Compromise is required during the design stage.

### 10. Flywheel Diode Selection

The flywheel diode is turned on and carries load current during the off time. The average diode current depends on the P-Channel switch duty cycle. At high input voltages, the diode conducts most of the time. In case of  $V_{IN}$  approaches  $V_{OUT}$ , the diode conducts only a small fraction of the cycle. While the output terminals are shorted, the diode will subject to its highest stress. Under this condition, the diode must be able to safely handle the peak current circulating in the loop. So, it is important to select a flywheel diode that can meet the diode peak current and average power dissipation requirements. Under normal conditions, the average current conducted by the flywheel diode is given by:

$$I_D = \frac{V_{IN} - V_{OUT}}{V_{IN} + V_F} \times I_{OUT}$$

Where  $I_D$  is the average diode current and  $V_F$  is the forward diode voltage drop.

A fast switching diode must also be used to optimize efficiency. Schottky diodes are ideal for low forward drop and fast switching times.

### 11. Input and Output Capacitor Selection ( $C_{IN}$ and $C_{OUT}$ )

In continuous mode operation, the source current of the P-Channel MOSFET is a square wave of duty cycle  $(V_{OUT} + V_F)/V_{IN}$ . We must select a low ESR input capacitor that can support the maximum RMS input current to prevent large input voltage transients. The maximum RMS input current, can be estimated by the equation below:

$$I_{RMS(MAX)} \approx I_{OUT} \times \frac{V_{OUT}(V_{IN} - V_{OUT})^{\frac{1}{2}}}{V_{IN}}$$

$I_{RMS(MAX)}$  has a maximum value at  $V_{IN} = 2V_{OUT}$ , where  $I_{RMS(MAX)} = I_{OUT}/2$ . As a general practice, this simple worst-case condition is used for design. Selecting of the output capacitor, the required effective series resistance (ESR) of the capacitor decide the  $C_{OUT}$  and the capacitance will be adequate for filtering unless the ESR requirement is met. The output voltage ripple,  $V_{RIPPLE}$  is approximated by:

$$V_{RIPPLE} \approx I_{L-RIPPLE(P-P)} \times \left( ESR + \frac{1}{4F_{OSC}C_{OUT}} \right)$$

Where  $F_{OSC}$  is the switching frequency and ESR is the effective series resistance of the output capacitor. We can see from equation 4 that the output voltage ripple contributed by two parts. For a better performance, Low ESR tantalum capacitors should be used. The major contributor is the capacitor ESR for most. Ordinary aluminum-electrolytic capacitors have high ESR and should be avoided while higher quality Low ESR aluminum-electrolytic capacitors are acceptable and relatively inexpensive. Surface-mount tantalum capacitors are better and provide neat and compact solution for space sensitive applications.

## ■ DESCRIPTION INFORMATION(Cont.)

**12. PCB Layout Recommendations**

Good PCB layout is important in switching mode power conversion. Careful PCB layout can minimize ground bounce, EMI noise and unwanted feedbacks that can affect the converter performance.

**13. Grounding**

The output power return ground, the input power return ground and the device power ground should be connected at the Star-ground. Feedback signal path must be separated from the main current path and sensing directly at the anode of the output capacitor. All high current running paths must be thick enough for current flowing through and producing insignificant voltage drop along the path.

**14. Components Placement**

Power components including input capacitor, inductor and output capacitor must be placed as close as possible. All connecting traces must be short, direct and thick. In order to avoid unwanted injection of noise into the feedback path high current flowing and switching paths must be kept away from the feedback pin terminal.

**15. Feedback Path**

Feedback of the output voltage must be separated from the power path. The output voltage sensing trace to the feedback pin should be connected to the output voltage directly at the anode of the output capacitor.



■ TYPICAL APPLICATION CIRCUIT

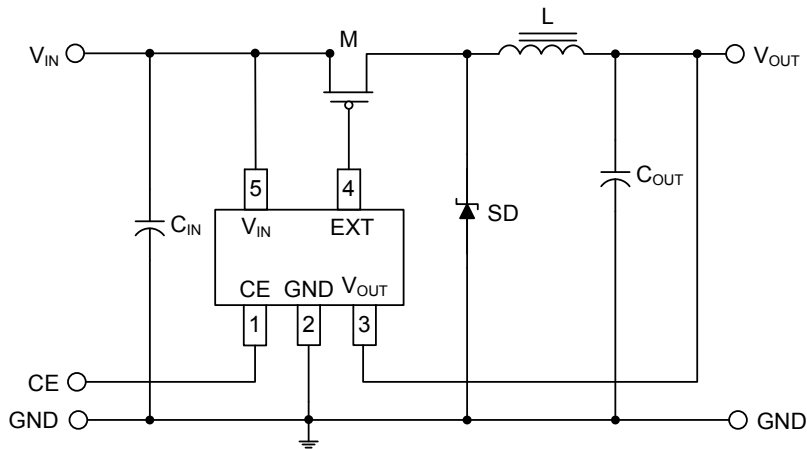

UTC assumes no responsibility for equipment failures that result from using products at values that exceed, even momentarily, rated values (such as maximum ratings, operating condition ranges, or other parameters) listed in products specifications of any and all UTC products described or contained herein. UTC products are not designed for use in life support appliances, devices or systems where malfunction of these products can be reasonably expected to result in personal injury. Reproduction in whole or in part is prohibited without the prior written consent of the copyright owner. The information presented in this document does not form part of any quotation or contract, is believed to be accurate and reliable and may be changed without notice.