

Features

- 3A DC, 5A Peak Output Current
- 16V Max. Rated Supply Voltage
- Built-in "Free-Wheeling" Diodes
- Output dv/dt Limited to Reduce EMI
- External Dynamic Brake Control Switch With Undervoltage Sense
- Thermal and Current Limiting Protects Against Locked Rotor Conditions
- Provides Analog Current Sense and Reference Inputs
- Decode Logic with Illegal Code Rejection

Applications

- Drive Spindle Motor Controller
- 3 Phase Brushless DC Motor Controller
- Brushless DC Motor Driver for 12V Battery Powered Appliances
- Phased Driver for 12V DC Applications
- Logic Controlled Driver for Solenoids, Relays and Lamps

Description

The HIP4011 motor driver is intended for three phase Brushless motor control at continuous output currents up to 3A. It accepts inputs from buffered Hall effect sensors and drives three motor windings, regulating the current through an external current sensing resistor, according to an analog control input. Output "freewheeling" diodes are built in and output dv/dt is limited to decrease the generated EMI. Thermal and current limiting are used to protect the device from locked rotor conditions. A brake control input forces all outputs to ground simultaneously to provide dynamic braking, and an internal voltage sensor does the same when the supply drops below a predetermined switch point. Power down braking energy is stored in an external capacitor.

Ordering Information

PART NUMBER	TEMPERATURE RANGE	PACKAGE
HIP4011IS	-40°C to +85°C	15 Pin Plastic SIP Surface Mount

Pinout

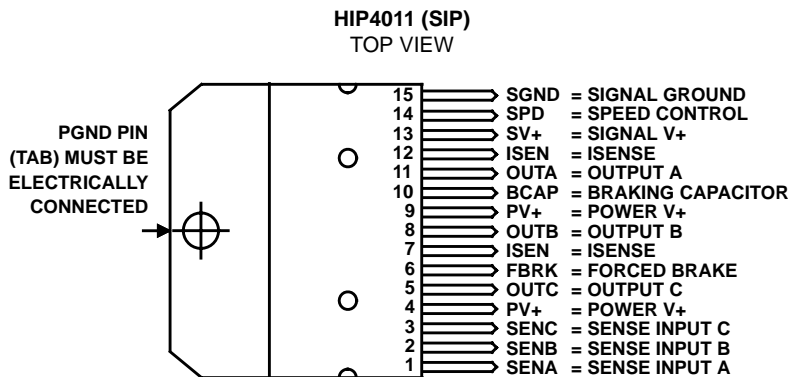

OUTPUT TRUTH TABLE

SENSOR INPUTS			FORCE BRAKE INPUT*	OUTPUTS		
A	B	C	FBRK	A	B	C
0	0	0	0	OFF	OFF	OFF
1	0	0	0	1	OFF	0
0	1	0	0	0	1	OFF
1	1	0	0	OFF	1	0
0	0	1	0	OFF	0	1
1	0	1	0	1	0	OFF
0	1	1	0	0	OFF	1
1	1	1	0	OFF	OFF	OFF
X	X	X	1	0	0	0

* Undervoltage and Force Brake logic truth table entries are identical.

"X" = Don't Care

Specifications HIP4011

Absolute Maximum Ratings

Supply Voltage, SV+ or PV+	-1V to +16V
Referred to SGND or PGND (Note 1)	
Output Current, Continuous	3A
Output Current, Peak (Note 2)	5A
Substrate (PGND) Current	1A
Logic Input Current	-20mA to +20mA
(Clamped to SV+ and SGND)	

Thermal Information

Thermal Resistance	θ_{JA}	θ_{JC}
15 Lead SIP Power Package	45°C/W	3°C/W
Power Dissipation (Note 3)	25W	
Junction Temperature Range, Operating	+150°C	
Storage Temperature Range	-55°C to +150°C	
Power Dissipation		
Up to +125°C without heat sink	0.56W	
Above +125°C without Heat Sink	Derate Linearly at 22mW/°C	
Up to +125°C with Infinite Heat Sink	8.33W	
Above +125°C with Infinite Heat Sink	Derate Linearly at 333mW/°C	
Lead Temperature (During Soldering)		
At a Distance 1/16 inch ±1/32 inch (1.59mm ±0.79mm)		
from Case for 10s Max.	+265°C	

NOTES:

1. PV+ and SV+ are to be tied together, as are PGND and SGND.
2. Operating above the continuous current rating causes a decrease in operating life.
3. Derate power dissipation above case temperature of +75°C at 0.33 Watts/°C.

CAUTION: Stresses above those listed in "Absolute Maximum Ratings" may cause permanent damage to the device. This is a stress only rating and operation of the device at these or any other conditions above those indicated in the operational sections of this specification is not implied.

Electrical Specifications $T_A = +25^\circ\text{C}$ and $SV+ = PV+ = 10.4\text{V}$ to 13.2V , Unless Otherwise Specified

PARAMETERS	TEST CONDITION	MIN	TYP	MAX	UNITS
SUPPLY (SV+) CURRENT					
No Drive	Outputs Off	-	-	10	mA
With Drive	Outputs On	-	-	15	mA
LOGIC INPUT CURRENT					
Sensor Inputs	SENA, SENB & SENC = 0V to 3V	-0.5	-	-1.5	mA
Brake Input	FBRK = 0.8V to 2.4V	50	-	150	μA
LOGIC INPUT THRESHOLDS					
Sensor Inputs	Logic "0" Input Voltage	-	-	1.8	V
Sensor Inputs	Logic "1" Input Voltage	3	-	-	V
Brake Input	Logic "0" Input Voltage	-	-	0.8	V
Brake Input	Logic "1" Input Voltage	2.4	-	-	V
AMPLIFIER INPUT (SPD)					
Bias Current		-	-	700	nA
Offset Voltage		-	-	3	mV
Input Range (Linear)		0	-	1	V
Input Impedance		1	-	-	MΩ
System Bandwidth	(Note 1)	-	35	-	kHz
Current Limit	$R_{sense} = 0.20\Omega$	-	5	-	A
THERMAL LIMIT					
Threshold		-	155	-	°C
Hysteresis		-	40	-	°C
OUTPUT DRIVERS					
On Saturation (See Note 5)	$I_{OUT} = 3A, V_{PMOS} + V_{NMOS}$	-	-	2.2	V
On Saturation (See Note 5)	$I_{OUT} = 0.6A, V_{PMOS} + V_{NMOS}$	-	-	0.44	V
Off Leakage	$PV+ > V_{OUT} > PGND$ or I_{SEN}	-	-	1	mA
Slew Rate	(See Note 2)	-	0.5	-	V/μS

HIP4011

Electrical Specifications $T_A = +25^\circ\text{C}$ and $SV+ = PV+ = 10.4\text{V}$ to 13.2V , Unless Otherwise Specified (Continued)

PARAMETERS	TEST CONDITION	MIN	TYP	MAX	UNITS
FREEWHEEL DIODES					
Forward Drop	$I_{OUT} = 1\text{A}$	-	-	1.5	V
INTERNAL BRAKE DRIVER					
Undervoltage Trip Point, PV+	(See Note 3)	2.7	-	3.3	V
Hysteresis	(See Note 4)	40	-	60	%
On Saturation	Each N_{MOS} , $I_{OUT} = 3\text{A}$	-	-	0.4	V
BRAKE CAPACITOR (BCAP)					
Discharge Leakage	$SV+ = PV+ = 3\text{V}$ to 12V , $BCAP = 10\text{V}$	-	-	5	μA

NOTES:

1. The system bandwidth is fixed by an internal RC network around the amplifier.
2. Internal limiting of turn on and turn off drive is used to limit output dv/dt .
3. The braking action starts at the given trip point with a falling supply voltage.
4. Hysteresis causes the brake to be removed at a higher trip point with a rising supply voltage.
5. This value includes the combined voltage drops of one upper plus one lower switch at the indicated current.

Functional Block Diagram

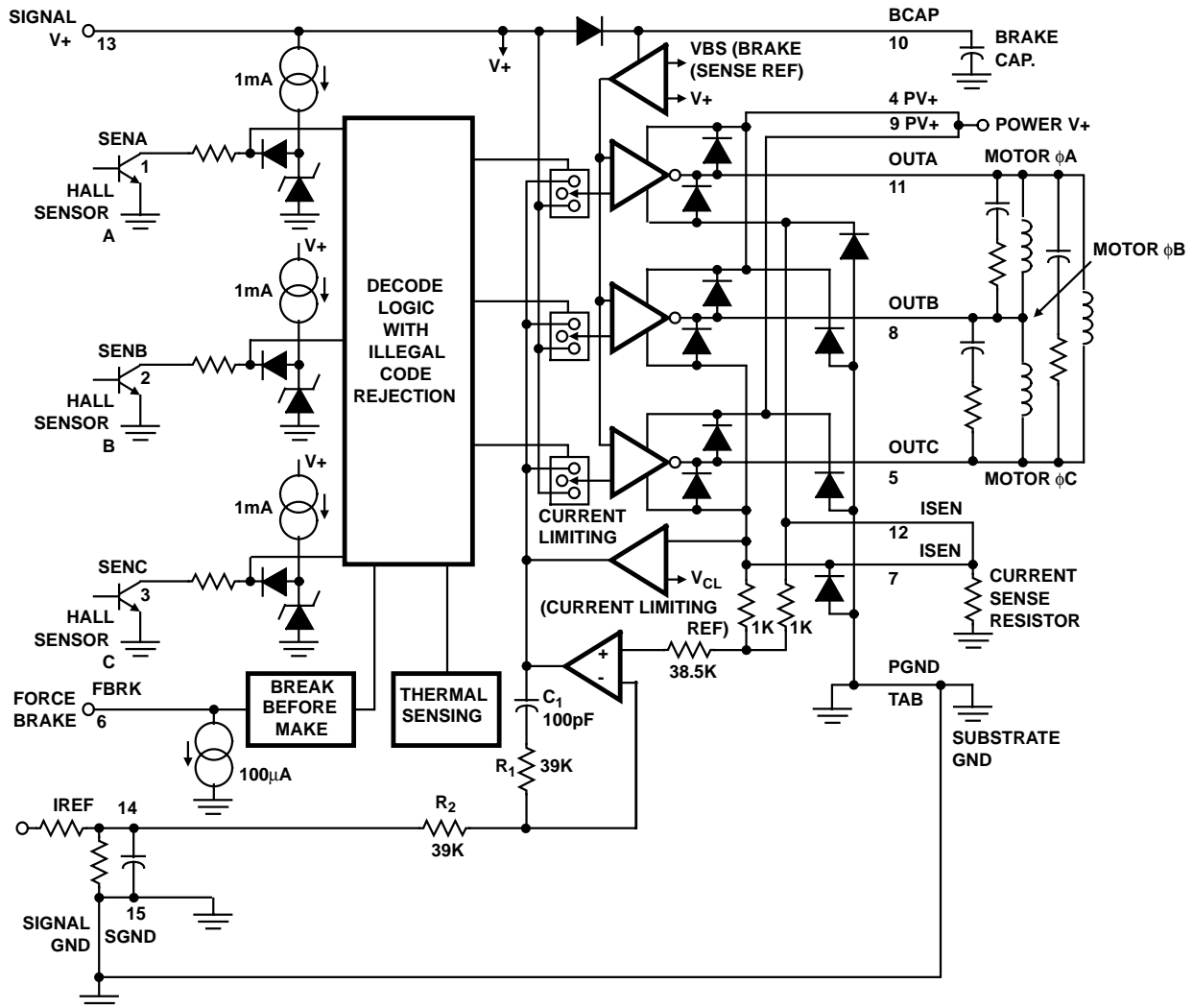

All Intersil semiconductor products are manufactured, assembled and tested under **ISO9000** quality systems certification.

Intersil products are sold by description only. Intersil Corporation reserves the right to make changes in circuit design and/or specifications at any time without notice. Accordingly, the reader is cautioned to verify that data sheets are current before placing orders. Information furnished by Intersil is believed to be accurate and reliable. However, no responsibility is assumed by Intersil or its subsidiaries for its use; nor for any infringements of patents or other rights of third parties which may result from its use. No license is granted by implication or otherwise under any patent or patent rights of Intersil or its subsidiaries.

For information regarding Intersil Corporation and its products, see web site <http://www.intersil.com>

Sales Office Headquarters

NORTH AMERICA

Intersil Corporation
P. O. Box 883, Mail Stop 53-204
Melbourne, FL 32902
TEL: (407) 727-9207
FAX: (407) 724-7240

EUROPE

Intersil SA
Mercure Center
100, Rue de la Fusee
1130 Brussels, Belgium
TEL: (32) 2.724.2111
FAX: (32) 2.724.22.05

ASIA

Intersil (Taiwan) Ltd.
Taiwan Limited
7F-6, No. 101 Fu Hsing North Road
Taipei, Taiwan
Republic of China
TEL: (886) 2 2716 9310
FAX: (886) 2 2715 3029