

BALLAST CONTROL IC

The KA7522 is a electronic ballast controller for fluorescent inverter systems. It contains whole function in KA7521, current feed back and preheating time controlled by temperature sensing.

FEATURES

- 3-step soft start
- Input voltage limit & Brown out
- Non Lamp detect, & Lamp reset
- ZVS Guard control
- Current feedback control
- Preheating time controlled by temperature sensing

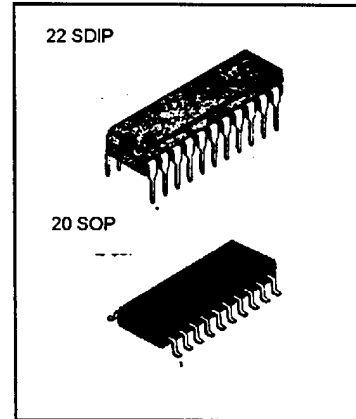

ORDERING INFORMATION

Device	Package	Operating Temperature
KA7522	22 SDIP	-25 ~ + 100 °C
KA7522D	20 SOP	-25 ~ + 100 °C

BLOCK DIAGRAM

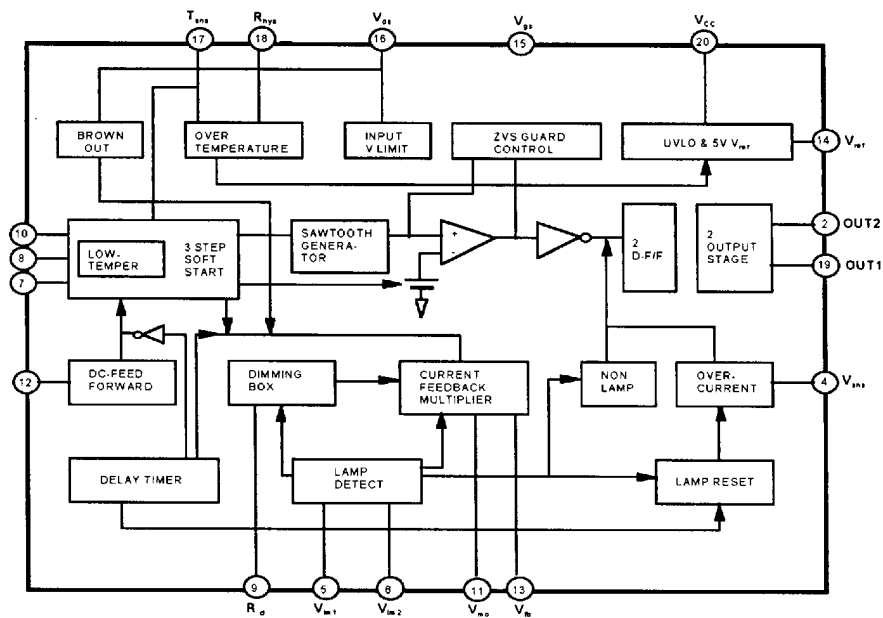

ABSOLUTE MAXIMUM RATINGS ($T_A = 25\text{ }^\circ\text{C}$, unless otherwise specified)

Characteristic	Symbol	Value	Unit
Supply Voltage	V_{CC}	20	V
Peak driver output current	I_{OP}	500	mA
Operating ambient temperature	T_{OPR}	-25 ~ +100	$^\circ\text{C}$
Storage temperature	T_{STG}	-65 ~ +150	$^\circ\text{C}$

ELECTRICAL CHARACTERISTICS

($V_{CC} = 12\text{V}$, $T_A = 25\text{ }^\circ\text{C}$, unless otherwise specified)

Characteristics	Symbol	Test Conditions	Min	Typ	Max	Unit
Under Voltage Lock Out Section						
Start-Up Threshold Voltage	V_{ST}		11.4	12.4	13.4	V
UVLO Hysteresis	V_{THS}		3.6	4.2	4.8	V
Start-Up Supply Current	I_{ST}	$V_{CC} = 9\text{V}$	0.5	0.8	1.1	mA
Operating Supply Current	I_{CC}	$V_{CC} = 14\text{V}$, No Load	8	10.5	13	mA
Reference Section						
Reference Voltage	V_{REF}		5.0	5.1	5.2	V
Load Regulation	ΔV_{REF}	$0 < I_{REF} < 5\text{mA}$	—	5	20	mV
Preheating Section						
Preheating Frequency	F_P	$V_{CS} = 0\text{V}$	125	145	165	KHz
Preheating Time Current	I_P	$V_{CS} = 0\text{V}$	8	14	20	μA
Preheating Dead Time	T_{PD}		2.5	3	3.5	μs
Oscillator Section						
Amplitude	$V_{(OSC)}$		3.0	3.4	3.8	V
Normal Frequency	F_N		80	100	120	KHz
Normal Dead Time	T_{ND}	$V_{CS} = 2\text{V}$	2.4	2.9	3.4	μs
3-step Frequency Section						
Preheating Voltage Range	V_{PR}		0.6	1	1.4	V
Soft start Voltage Range	V_{SR}		1.2	1.6	2.0	V

ELECTRICAL CHARACTERISTICS

(V_{CC} = 12V, T_A = 25 °C, unless otherwise specified)

Characteristic	Symbol	Test Conditions	Min	Typ	Max	Unit
Dimming Control Section						
Dimming Current	I _{DIM}	R _D = 120K Ω	26	33	40	μ A
Option Comparator						
Option Comparator Voltage	V _{OPT}		2.7	3.1	3.5	V
Option Section						
Rising time	T _R	No Load, V _{CC} = 10V	—	80	120	ns
Falling time	T _F	No Load, V _{CC} = 10V	—	20	100	ns
High Voltage	V _{OH}	I _O = 30mA, V _{CC} = 10V	7	8	—	V
Low Voltage	V _{OI}	I _O = 30mA, V _{CC} = 10V	—	0.1	0.4	V
Over Temperature Protection						
High Temperature Voltage	V _{HT}		0.4	0.8	1.2	V
Reset Temperature Voltage	V _{RT}		1.7	2.1	2.5	V
Hysteresis Max Current	I _{HYS}		80	100	120	μ A
Input Voltage Limit						
High Limit Voltage	V _{H(LIM)}	R _{DS} = 12K Ω	4.8	5.3	5.8	V
High Limit Hysteresis	V _{HYS(H)}	R _{DS} = 12K Ω	4.3	4.8	5.3	V
Low Limit Voltage	V _{L(LIM)}	R _{DS} = 12K Ω	1.1	1.6	2.1	V
Low Limit Hysteresis	V _{HYS(L)}	R _{DS} = 12K Ω	1.6	2.1	2.6	V
Lamp Detection						
Lamp1 Detect Voltage	V _{IM1}		1.2	1.4	1.6	V
Lamp2 Detect Voltage	V _{IM2}		1.2	1.4	1.6	V
Temperature Sense						
Negative Preheating Current	I _{PC}		2	6	10	μ A
Multiplier Section						
Multiplier Gain (NOTE)	G _M		—	0.01	0.02	
Multiplier Input 1 Current	I _{ML}	R _{ML} = M Ω, V _{ML} = 27V	22	26	30	μ A
Multiplier Input 2 Current	I _{FB}	V _{FB} = GND	18	30	42	μ A

ELECTRICAL CHARACTERISTICS

($V_{CC} = 12V$, $T_A = 25\text{ }^\circ\text{C}$, unless otherwise specified)

Characteristic	Symbol	Test Conditions	Min	Typ	Max	Unit
Brown Out Section						
Brown out Voltage	V_{BO}		2.3	2.7	3.1	V
Brown out Hysteresis	V_{BYS}		2.6	3	3.4	V
Time Delay Section						
Start Feedback Voltage	V_{SF}		2.5	2.9	3.3	V
DC Feed Forward Section						
Feed Forward Current	I_{FF}		19	23	27	μA
ZVS Guard Section0.4						
High Sense Voltage	V_{HS}		0.05	0.2	0.4	mV
Low Sense Voltage	V_{LS}		0.05	0.2	0.4	mV

PIN CONNECTION (top view)

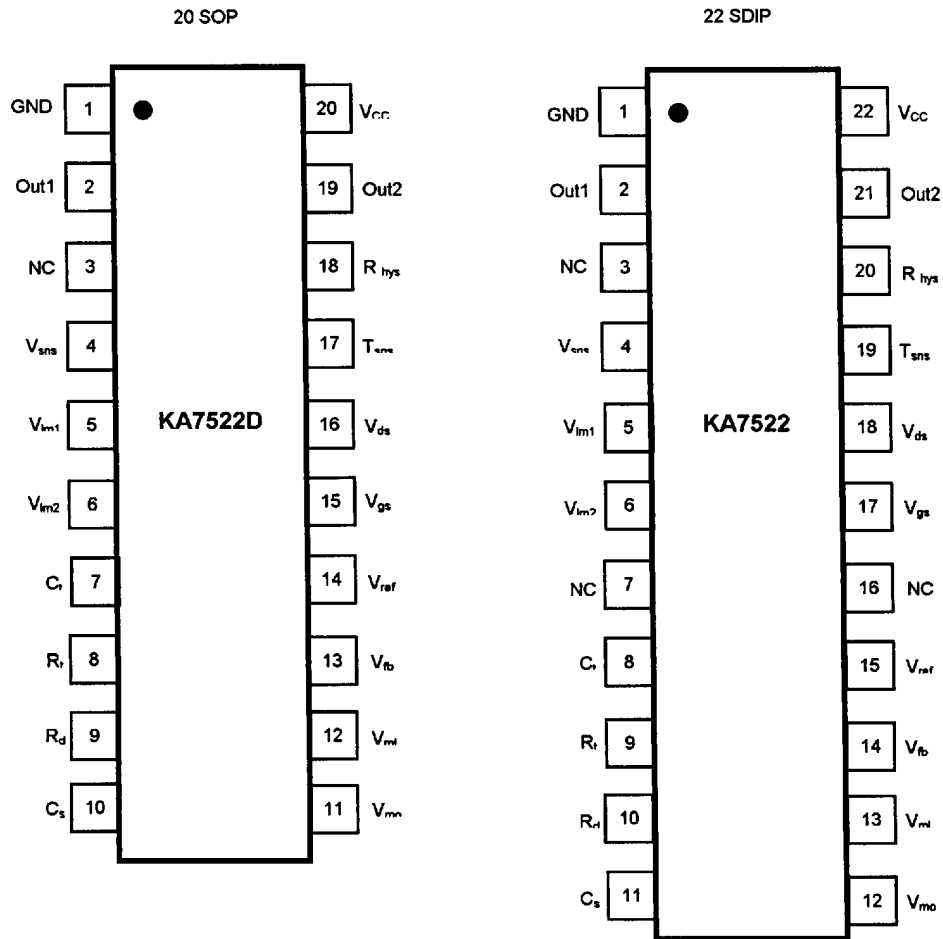

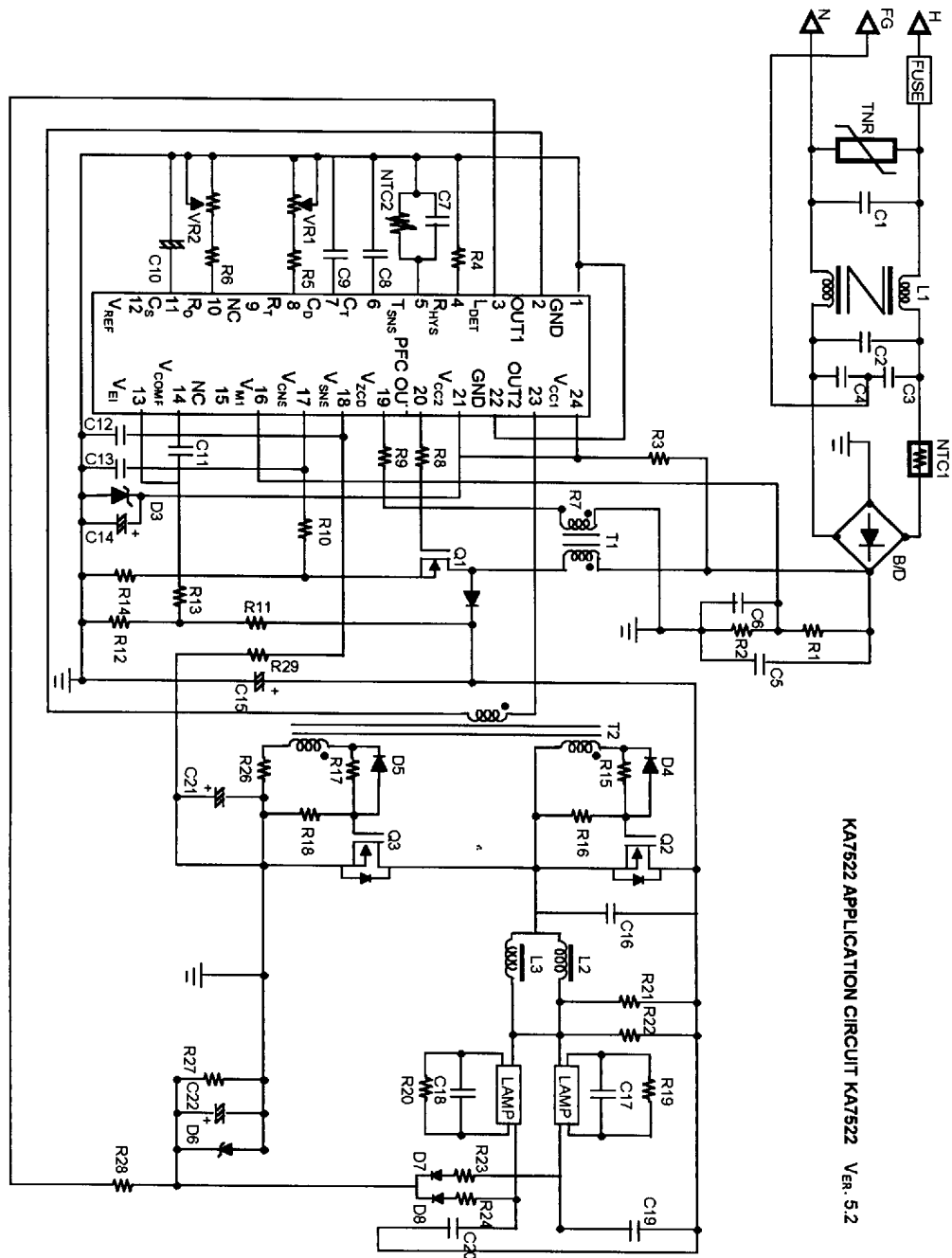

KA7522 APPLICATION CIRCUIT KA7522 Ver. 5.2

PARTS LIST (KA7522/D)

Part	Value	Part	Value	Part	Value
R1	100K Ω 1W	R30	1K Ω	D1	1N4937
R2	100K Ω 1W	VR1	500K Ω	D2	1N4937
R3	2K Ω			D3	1N4937
R4	22K Ω	C1	0.1 μ F 250V	D4	1N4937
R5	1K Ω	C2	0.1 μ F 250V	D5	1N4937
R6	10 Ω 1/2W	C3	4700pF 250V	D6	1N4937
R7	50K Ω	C4	4700pF 250V		
R8	36K Ω	C5	0.1 μ F 315V		
R9	1K Ω	C6	22 μ F 24V		
R10	1K Ω	C7	330 μ F 10V		
R11	2K Ω	C8	10 μ F 10V	ZD1	15V 1W
R12	1.2 Ω	C9	104 10V	ZD2	3.9V 0.5W
R13	100 Ω 1W	C10	104 10V	ZD3	3.9V 0.5W
R14	22 Ω	C11	102 10V		
R15	22 Ω	C12	68 μ F 450V		
R16	1M Ω	C13	152 630V	Q1	KSP44
R17	12K Ω	C14	822 1000V	Q2	KSP44
R18	390K Ω	C15	822 1000V	Q3	IRF830
R19	390K Ω	C16	103 630V	Q4	IRF830
R20	1M Ω	C17	103 630V		
R21	1M Ω	C18	103 630V	L1	BSF-2125
R22	390K Ω	C19	103 630V	T1	EE1619
R23	390K Ω	C20	1 μ F 10V	T2	EI25
R24	30K Ω	C21	22 μ F 10V	T3	EI25
R25	1 Ω	C22	1 μ F 10V		
R26	30K Ω			B/D	KBL205
R27	12K Ω	TNR	12G471K	IC	KA7522D
R28	1M Ω	NTC1	10D-11		
R29	1M Ω	NTC2	KTD5-350	FUSE	250V/2A

42-DIP-600B

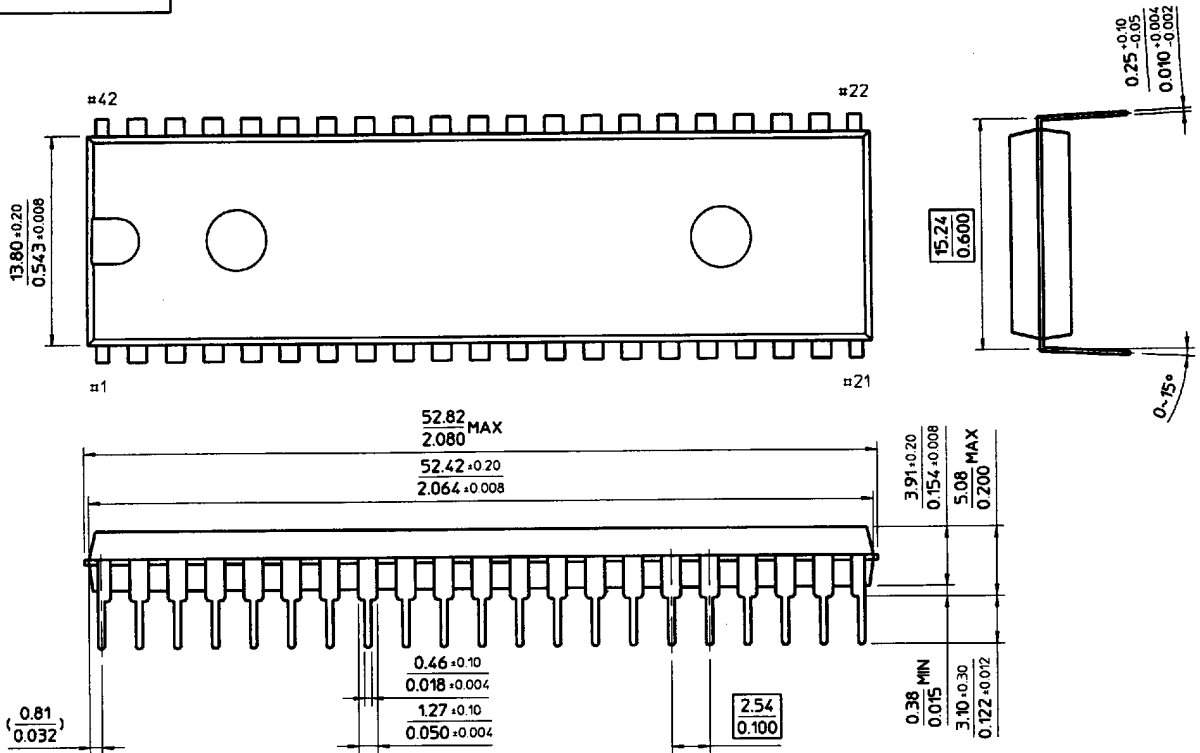

22-SDIP-300

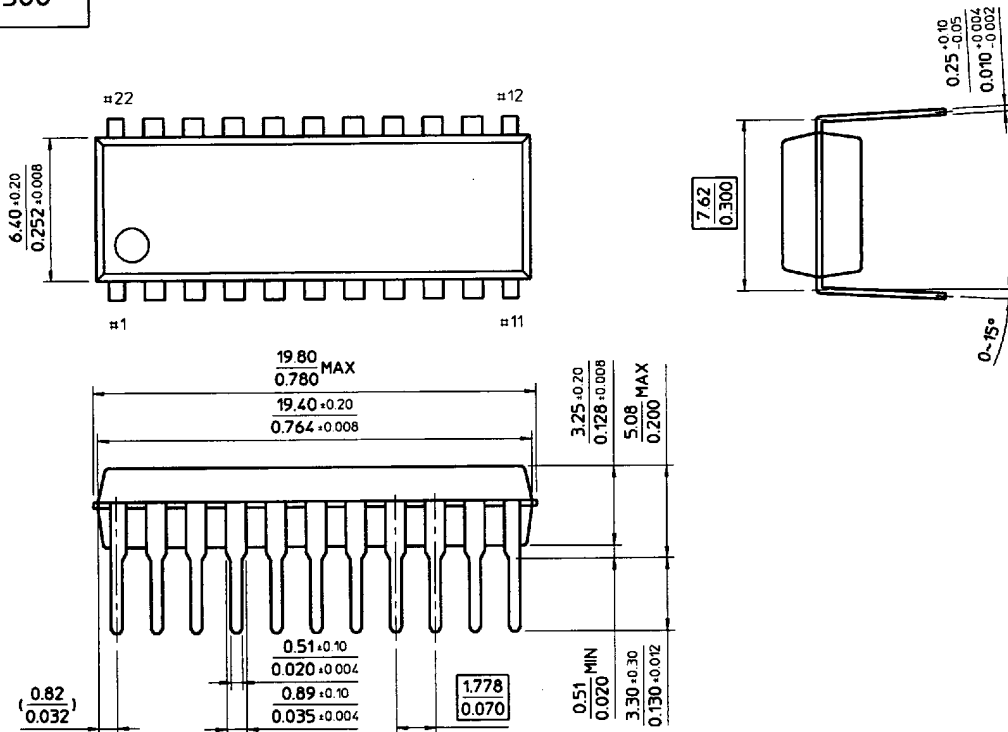

20-SOP-300

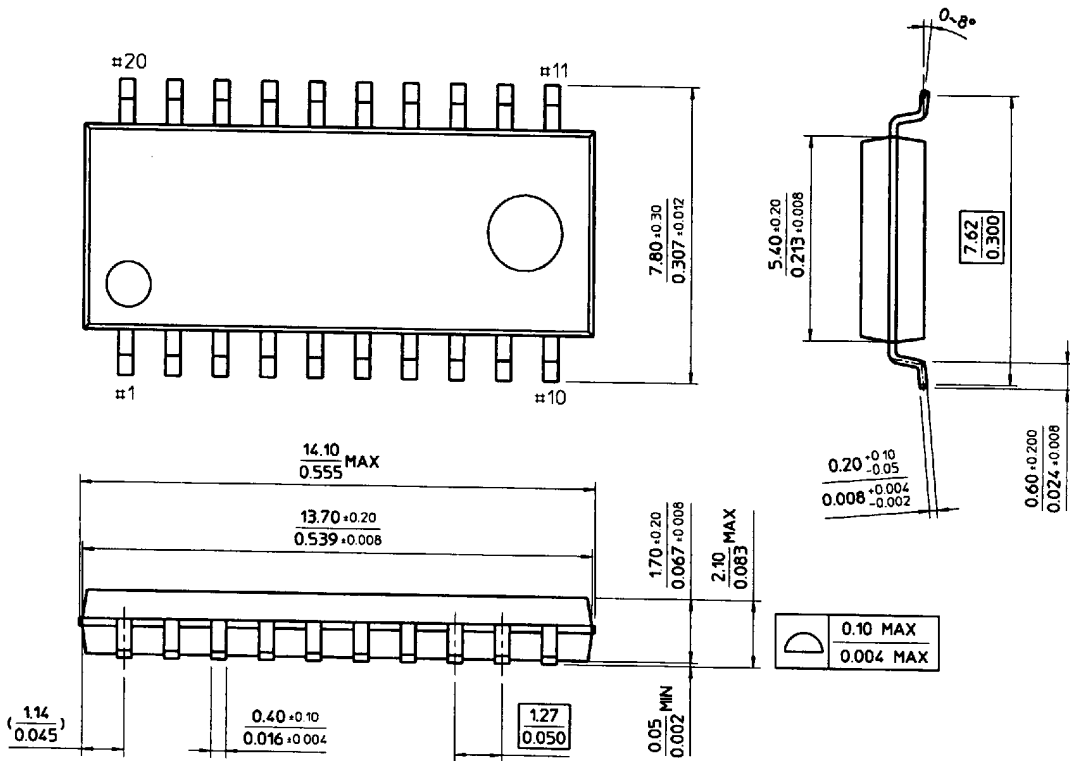

20-SOP-375

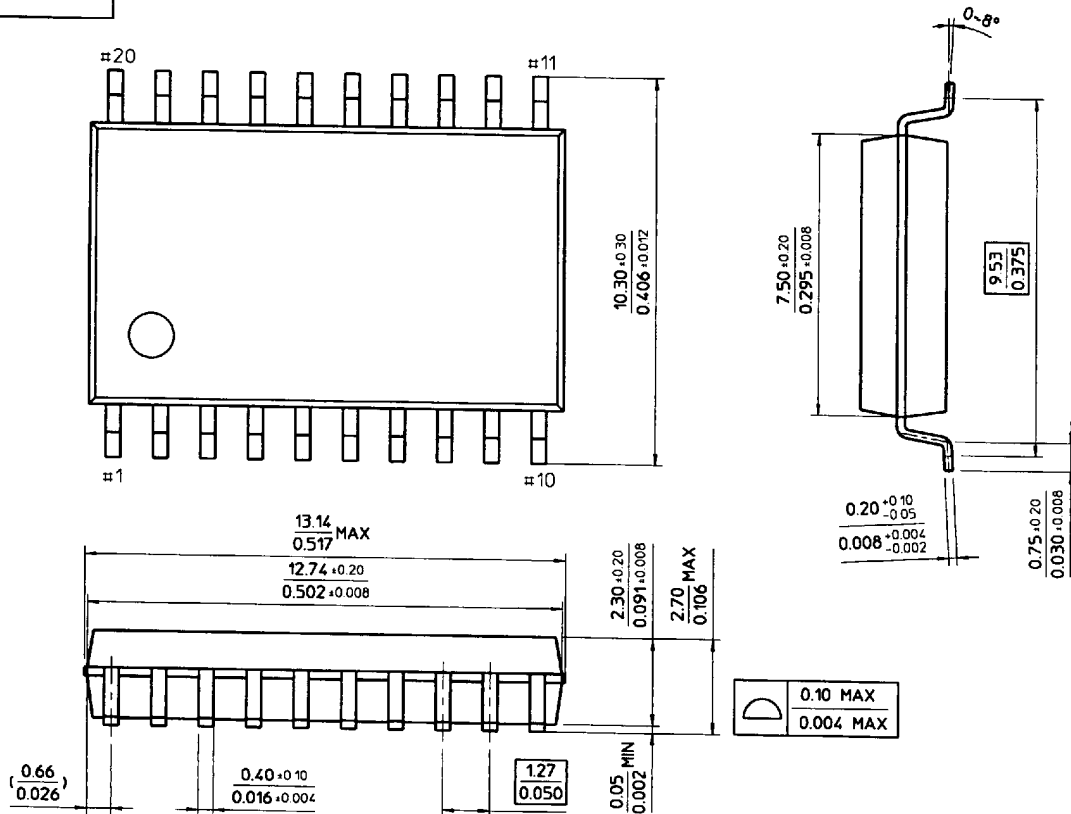

7964142 0036232 603

