

# MIC4802



## High Efficiency 800mA Single Channel Linear WLED Driver with Ultra Fast PWM™ Control

### General Description

The MIC4802 is a high efficiency White LED (WLED) driver designed to drive a single LED up to 800mA. The MIC4802 constant current driver is designed to drive high power LED's in various lighting applications. The MIC4802 provides the highest possible efficiency as this architecture has no switching losses present in traditional charge pumps or inductive boost circuits. It features a typical dropout of 280mV at 800mA. This allows the LEDs to be driven directly from the voltage source eliminating switching noise/losses present with the use of boost circuitry. The high accuracy ( $\pm 1\%$  Typical) current regulated WLED channel ensures uniform display illumination under all conditions. The brightness is controlled through an Ultra Fast PWM™ Control interface operating down to less than 1% duty cycle.

The MIC4802 is available in the 8-pin SOIC Epad package with a junction temperature range of  $-40^{\circ}\text{C}$  to  $+125^{\circ}\text{C}$ .

Datasheets and support documentation can be found on Micrel's web site at: [www.micrel.com](http://www.micrel.com).

### Features

- High Efficiency (no Voltage Boost losses)
- Ultra Fast PWM™ control (200Hz to 500kHz)
- Input voltage range: 3.0V to 5.5V
- Dropout of 280mV at 800mA
- Programmable LED current with external resistor
- Current accuracy of  $\pm 1\%$  typical

### Applications

- Bill board displays
- Marquee displays
- Instrument displays
- Architectural lighting

### Typical Application

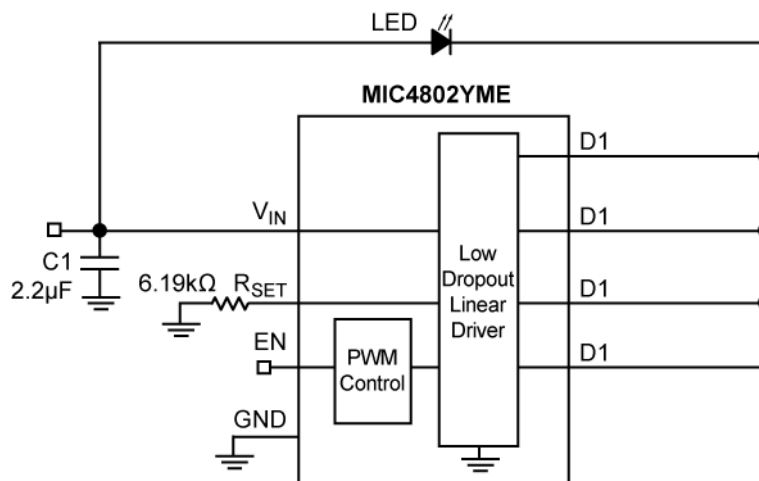

High Current Lighting Schematic

Ultra Fast PWM is a trademark of Micrel, Inc.

Micrel Inc. • 2180 Fortune Drive • San Jose, CA 95131 • USA • tel +1 (408) 944-0800 • fax + 1 (408) 474-1000 • <http://www.micrel.com>

January 2011

M9999-013111-B

## Ordering Information

Part Number	Temperature Range	Package
MIC4802YME	-40°C to +125°C	8-Pin EPAD SOIC

## Pin Configuration

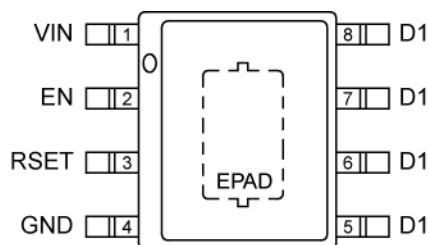

8-Pin Epad SOIC (ME)  
(Top View)

## Pin Description

Pin Number	Pin Name	Pin Function
1	VIN	Voltage Input. Connect at least 2.2 $\mu$ F ceramic capacitor between VIN and GND.
2	EN	Enable LED drivers. This pin can be used as a PWM input for dimming of WLEDs. Do not leave floating.
3	RSET	An internal 1.27V reference sets the nominal maximum WLED current. Example, apply a 6.19k $\Omega$ resistor between RSET and GND to set LED current to 830mA at 100% duty cycle.
4	GND	Ground.
5	D1	LED1 driver input. Connect LED anode to VIN and cathode to this pin. All D1 pins must be connected to the LED.
6	D1	LED1 driver input. Connect LED anode to VIN and cathode to this pin. All D1 pins must be connected to the LED.
7	D1	LED1 driver input. Connect LED anode to VIN and cathode to this pin. All D1 pins must be connected to the LED.
8	D1	LED1 driver input. Connect LED anode to VIN and cathode to this pin. All D1 pins must be connected to the LED.
EPAD	HS PAD	Heat sink pad. Not internally connected. Connect to ground.

**Absolute Maximum Ratings<sup>(1)</sup>**

Main Input Voltage ( $V_{IN}$ )	-0.3V to +6V
Enable Input Voltage ( $V_{EN}$ )	-0.3V to +6V
LED Driver Voltage ( $V_{D1}$ )	-0.3V to +6V
Power Dissipation	Internally Limited
Lead Temperature (soldering, 10sec.)	260°C
Storage Temperature ( $T_s$ )	-65°C to +150°C

**Operating Ratings<sup>(2)</sup>**

Supply Voltage ( $V_{IN}$ )	+3.0V to +5.5V
Enable Input Voltage ( $V_{EN}$ )	0V to $V_{IN}$
LED Driver Voltage ( $V_{D1}$ )	0V to $V_{IN}$
Junction Temperature ( $T_J$ )	-40°C to +125°C
Junction Thermal Resistance	
EPAD SOIC-8L ( $\theta_{JA}$ )	41°C/W

**Electrical Characteristics**

$V_{IN} = V_{EN} = 5V$ ,  $R_{SET} = 6.19k\Omega$ ;  $V_{D1} = 1.2V$ ;  $T_J = 25^\circ C$ , **bold** values indicate  $-40^\circ C \leq T_J \leq 125^\circ C$ ; unless noted.

Parameter	Conditions	Min	Typ	Max	Units
Current Accuracy <sup>(3)</sup>		747	830	913	mA
Drop-out	Where $I_{LED} = 90\%$ of LED current seen at $V_{DROP\,NOM} = 1.2V$ , 100% brightness level		280	<b>500</b>	mV
Ground/Supply Bias Current	$I_{OUT} = 830mA$		4.1	5.7	mA
Shutdown Current	$V_{EN} = 0V$		0.01	1	$\mu A$
<b>PWM Dimming</b>					
Enable Input Voltage ( $V_{EN}$ )	Logic Low			<b>0.2</b>	V
	Logic High	<b>1.2</b>			V
Enable Input Current	$V_{IH} \geq 1.2V$		0.01	1	$\mu A$
Current Source Delay (50% levels)	Shutdown to on		40	60	$\mu s$
	Standby to on		2		$\mu s$
	On to Standby		0.3		$\mu s$
Current Source Transient Time (10%-90%)	$T_{RISE}$		1		$\mu s$
	$T_{FALL}$		0.3		$\mu s$
Stand-by to Shutdown Time	$V_{EN} = 0V$	10	20	40	ms

**Notes:**

1. Exceeding the absolute maximum rating may damage the device.
2. The device is not guaranteed to function outside its operating rating.
3. As determined by average current based on  $R_{SET}$  resistance.

# Typical Characteristics

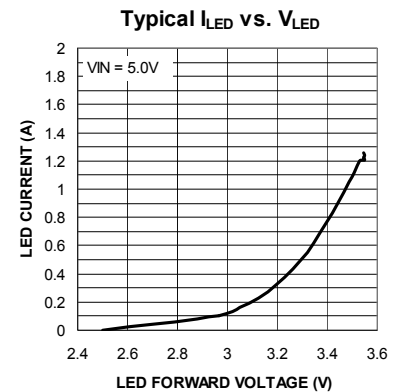
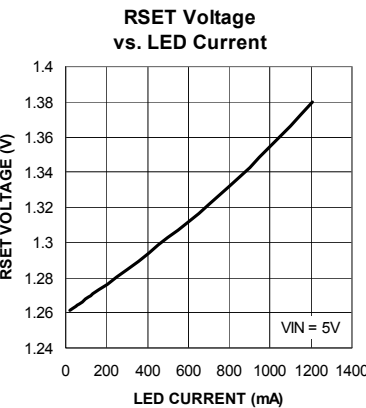
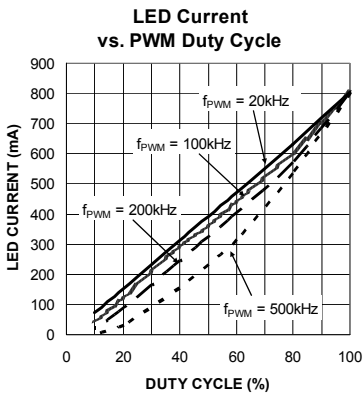
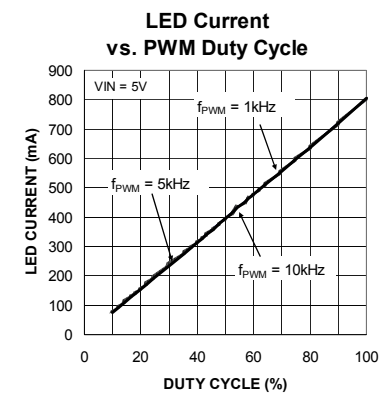
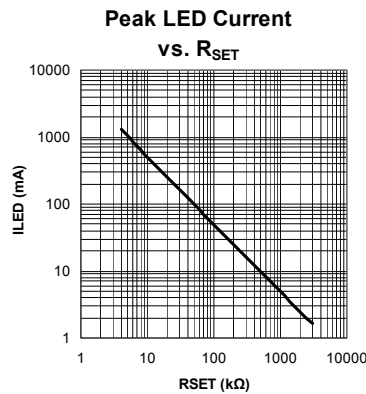
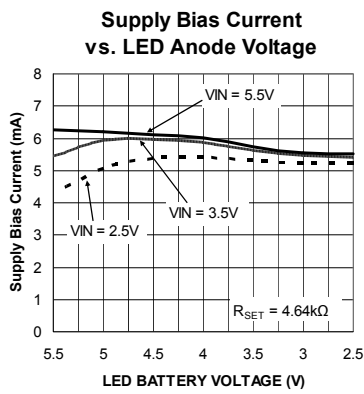
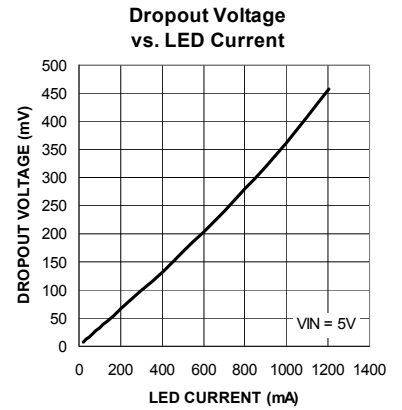
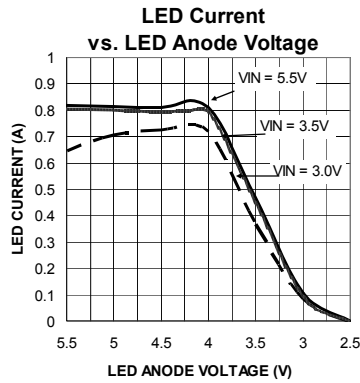
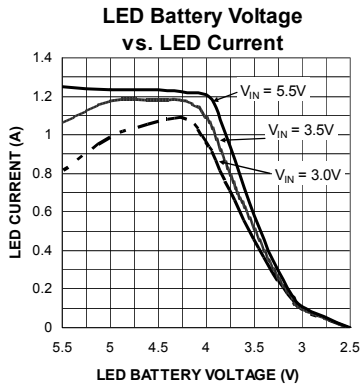

## Functional Characteristics

**LED Startup into 10% Duty Cycle**

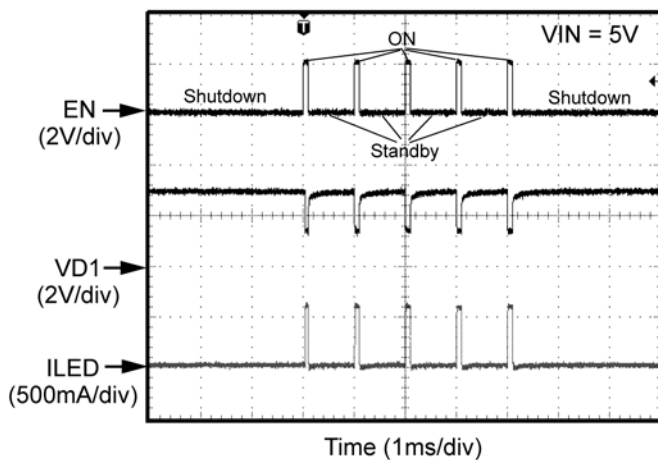

**Shutdown to ON**

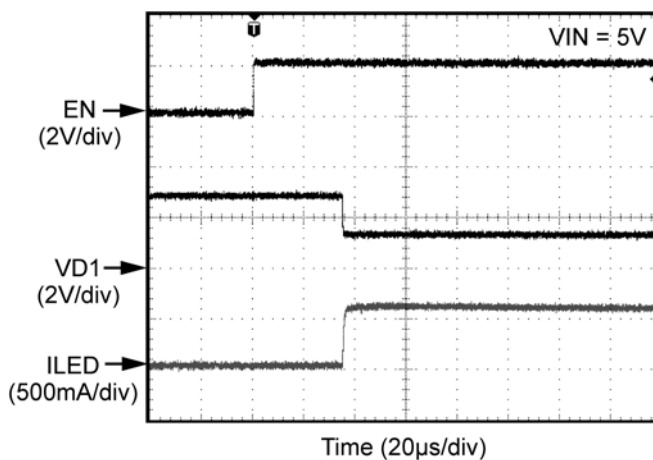

**Standby to ON**

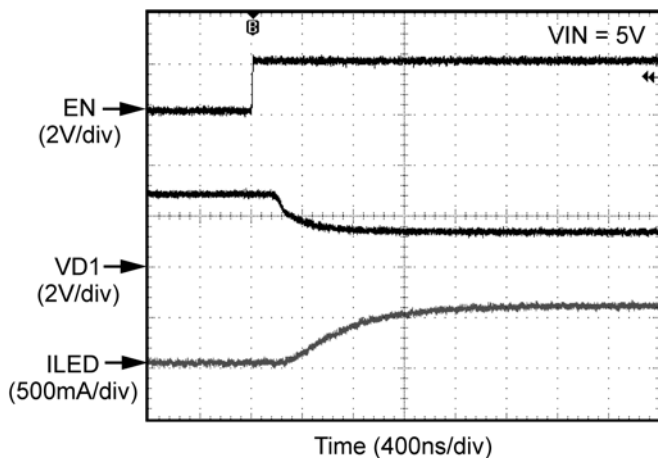

**ON to Standby**

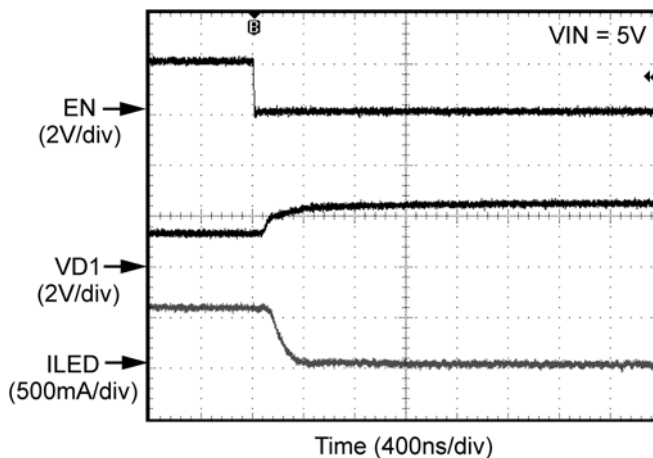

**ON to Shutdown**

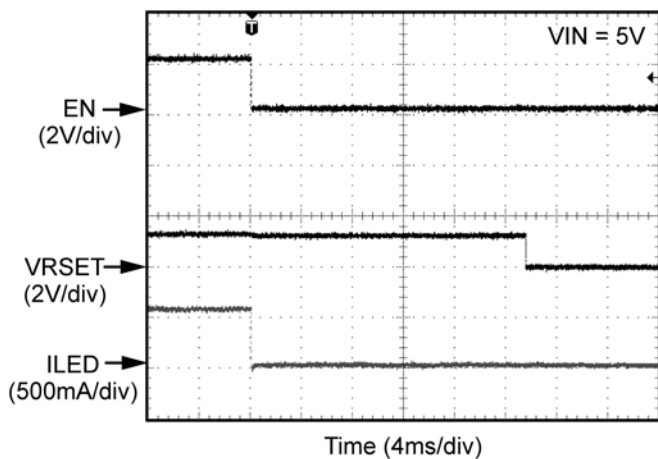

## Functional Diagram

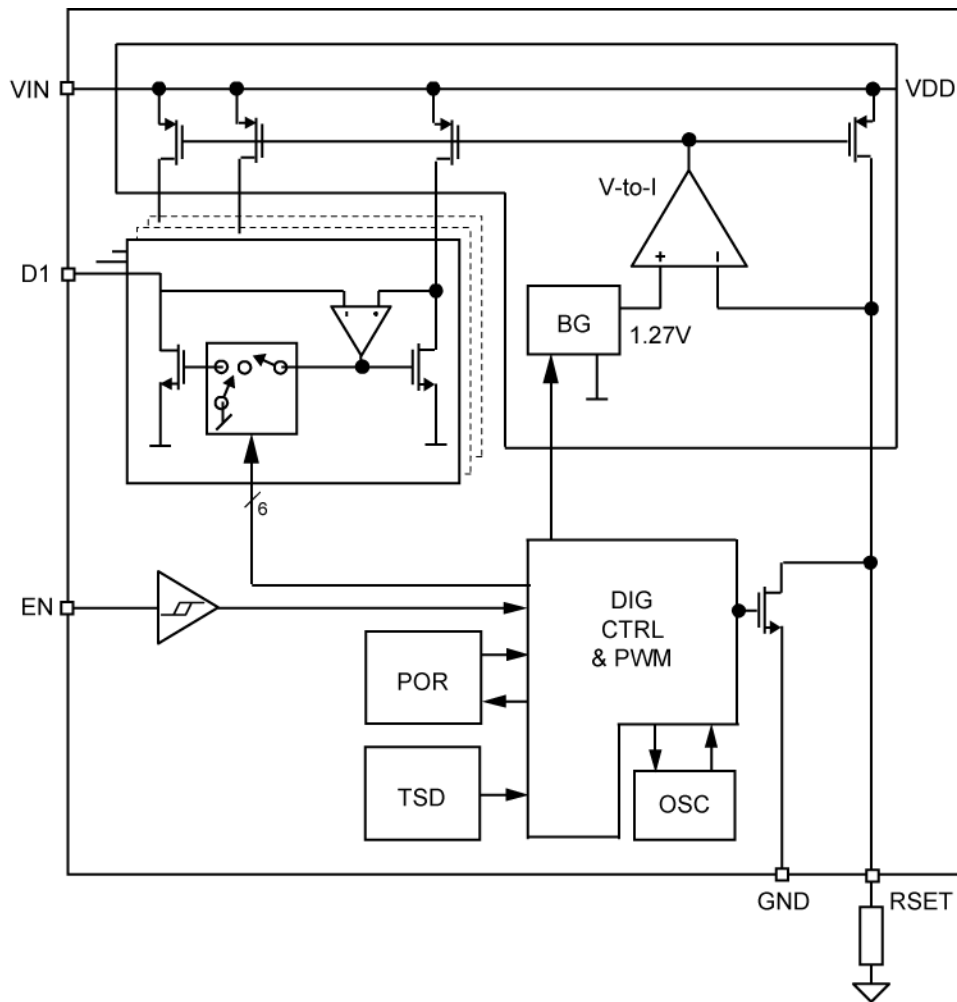

Figure 1. MIC4802 Functional Block Diagram

## Functional Description

The MIC4802 is a single channel linear LED driver with a maximum 800mA current capability. The LED driver is designed to maintain proper current regulation with LED current accuracy of  $\pm 10\%$ . The dropout is 280mV at 800mA. The low dropout of the linear drivers allows the LEDs to be driven directly from the battery voltage and eliminates the need for boost or large and inefficient charge pumps. The maximum LED current for each channel is set via an external resistor. Dimming is controlled by applying a PWM signal to the EN pin. The MIC4802 accommodates a wide PWM frequency range as outlined in the application information section.

## Block Diagram

As shown in Figure 1, the MIC4802 consists of current mirrors set to copy a master current determined by  $R_{SET}$ . The linear LED drivers have a designated control block for enabling and dimming of the LEDs. The MIC4802 dimming is controlled by the Ultra Fast PWM™ control block that receives PWM signals for dimming.

**VIN**

The input supply ( $V_{IN}$ ) provides power to the linear LED drivers and the control circuitry. The  $V_{IN}$  operating range is 3V to 5.5V. A minimum bypass capacitor of 1 $\mu$ F should be placed close to the input (VIN) pin and the ground (GND) pin. Refer to the layout recommendations section for details on placing the input capacitor (C1).

**EN**

The EN pin is equivalent to the enable pin for the linear drivers on the MIC4802. It can also be used for dimming applying a PWM signal. See the PWM Dimming Interface in the Application Information section for details. Pulling the EN low for more than 40ms puts the MIC4802 into a low  $I_Q$  sleep mode. The EN pin cannot be left floating; a floating enable pin may cause an indeterminate state on the outputs. The first pulse on the EN pin must be equal or greater than 60 $\mu$ s to wake the part up in a known state. This equates to an 8.3kHz PWM signal at equal or greater than 50% duty cycle. Higher PWM frequencies may be used but the first pulse must be equal or greater than 60 $\mu$ s.

**RSET**

The  $R_{SET}$  pin is used to set the peak current of the linear driver by connecting a  $R_{SET}$  resistor to ground. The theoretical average LED current can be estimated by equation (1):

$$I_{LED} \text{ (mA)} = 4920 * D / R_{SET} \text{ (k}\Omega) \tag{1}$$

$$R_{SET} \text{ (k}\Omega) = 4920 * D / I_{LED} \text{ (mA)} \tag{2}$$

D is the duty cycle of the LED current during PWM dimming. When the device is fully ON the duty cycle equals 100% (D = 1). A plot of  $I_{LED}$  versus  $R_{SET}$  is shown in Figure 2.

Due to DC losses across current paths internal and external to the package, the calculated  $R_{SET}$  resistance equation is modified by a factor K, where K is calculated to be 0.280k $\Omega$ .

$$R_{SET} \text{ (k}\Omega) = 4920 * D / I_{LED} \text{ (mA)} + 0.280 \text{ (k}\Omega) \tag{3}$$

$$I_{LED} \text{ (mA)} = 4920 * D / ((R_{SET} \text{ (k}\Omega) - 0.280 \text{ (k}\Omega)) \tag{4}$$

The modified LED current equation is more accurate in determining the actual LED current based on the RSET resistor value.

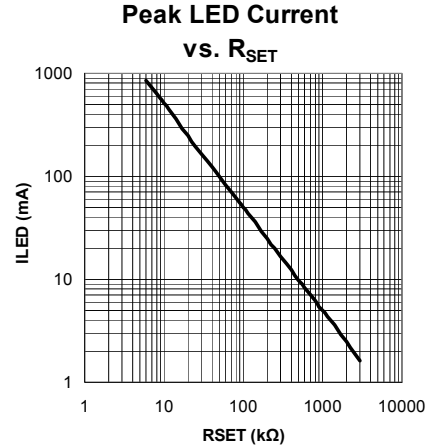

Figure 2. Peak LED Current vs.  $R_{SET}$

**D1**

The D1 pins are the linear driver inputs for the LED. Connect the anode of the LED to  $V_{IN}$  and the cathode to the D1 pins. All the D1 pins must be connected together. The D1 voltage at dropout is the minimum voltage required by the linear driver in order for the LED to be fully biased.

**GND**

The ground pin is the ground path for the linear driver. The ground of the input capacitor should be routed with low impedance traces to the GND pin and made as short as possible. Refer to the layout recommendations for more details.

## Application Information

### Ultra Fast PWM™ Dimming Interface

The MIC4802 supports a wide range of PWM control signal frequencies from 200Hz to 500kHz. This extremely wide range of control provides ultimate flexibility for handheld applications using high frequency PWM control signals.

WLED dimming is achieved by applying a pulse width modulated (PWM) signal to the END pin. For PWM frequencies between 200Hz – 10kHz the MIC4802 supports a duty cycle range from 1% to 100%, as shown in Figure 3. The MIC4802 incorporates an internal shutdown delay to ensure that the internal control circuitry remains active during PWM dimming. This feature prevents the possibility of backlight flickering when using low frequency PWM control signals. The MIC4802 also supports Ultra Fast PWM™ frequencies from 20kHz to 500kHz. Due to input signal propagation delay, PWM frequencies above 20kHz have a non-linear relationship between the duty cycle and the average LED current, as shown in Figure 4 and 5. Figures 6 through 9 show the WLED current response when a PWM signal is applied to the END pin<sup>(1)</sup>.

<sup>(1)</sup> From the low I<sub>Q</sub> sleep mode higher PWM frequencies above 15kHz require a logic high enable signal for 60μs to first enable the MIC4802 prior to PWM dimming.

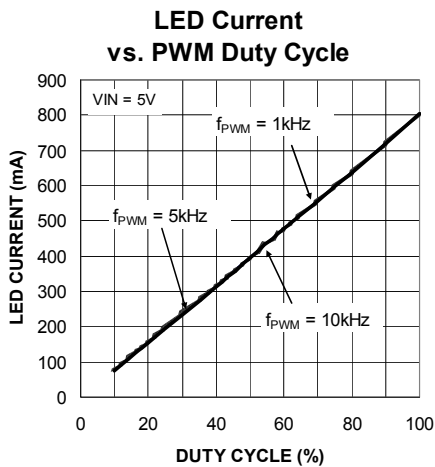

Figure 3. Average Current per LED Dimming by Changing PWM Duty Cycle for PWM Frequencies up to 20kHz

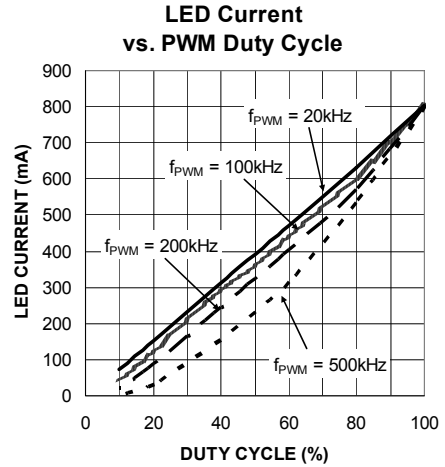

Figure 4. Channel Current Response to PWM Control Signal Frequencies from 50kHz to 500kHz

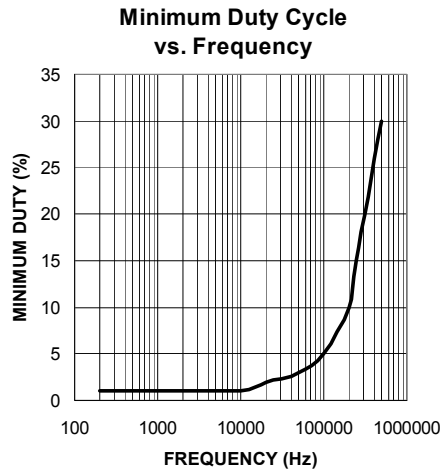

Figure 5. Minimum Duty Cycle for Varying PWM Frequency

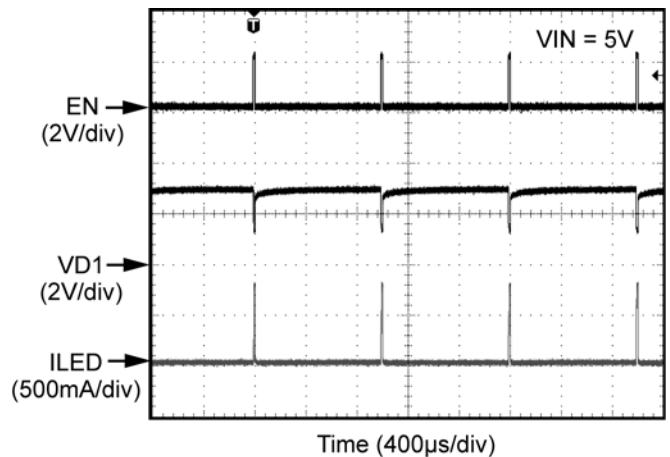

Figure 6. PWM Signal at 1% Duty Cycle (I<sub>avg</sub> = 8mA)



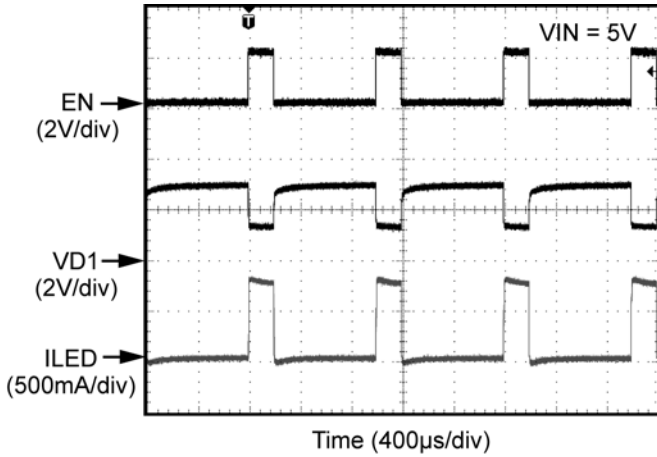

Figure 7. PWM Signal at 20% Duty Cycle ( $I_{avg} = 160mA$ )

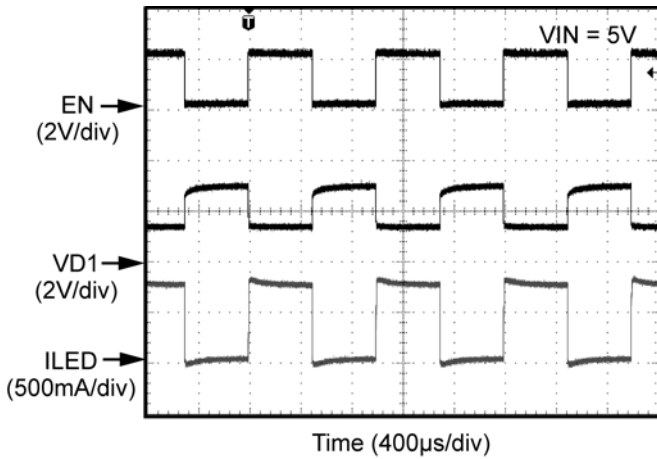

Figure 8. PWM Signal at 50% Duty Cycle ( $I_{avg} = 400mA$ )

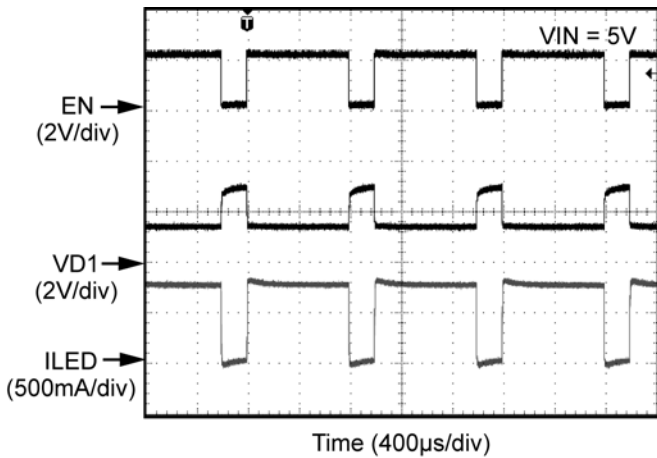

Figure 9. PWM Signal at 80% Duty Cycle ( $I_{avg} = 640mA$ )

**Thermal Consideration**

The MIC4802 thermal considerations involve calculating the junction temperature based on the voltage drop across the package and the LED current. The voltage drop across the package is equal to the voltage at D1 with respect to ground times the LED current.

$$P_{LOSS} = I_{LED} * V_{D1}$$

The temperature rise ( $\Delta T$ ) is calculated:

$$\Delta T = P_{LOSS} * \theta_{JA}$$

Assuming the  $I_{LED}$  is 800mA and  $V_{D1}$  is 500mV at 20°C room temperature, we can calculate the junction temperature:

$$T_J = T_A + \Delta T$$

$$T_J = 20^\circ C + 0.4W * 41^\circ C/W$$

$$T_J = 20^\circ C + 16.4^\circ C = 36.4^\circ C$$

The junction temperature will be 36.4°C.

## MIC4802 Typical Application Circuit

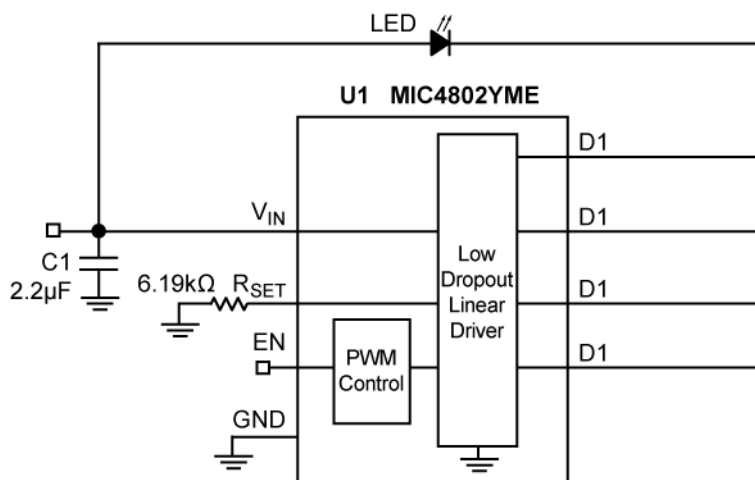

## Bill of Materials

Item	Part Number	Manufacturer	Description	Qty.
C1	C1608X5R0J225K	TDK <sup>(1)</sup>	Ceramic Capacitor, 2.2µF, 6.3V, X5R, Size 0603	1
	06036D225KAT2A	AVX <sup>(2)</sup>		
	GRM188R60J225KE19D	Murata <sup>(3)</sup>		
	VJ0603G225KXYAT	Vishay <sup>(4)</sup>		
LED	R42180	Seoul Semiconductor <sup>(5)</sup>	3.8W High Power WLED	1
R <sub>SET</sub>	CRCW06036K19FKEA	Vishay <sup>(4)</sup>	Resistor, 6.19kΩ, 1%, 1/16W, Size 0603	1
U1	MIC4802YME	Micrel, Inc. <sup>(6)</sup>	800mA Single Channel Ultra Fast PWM™ Linear WLED Driver	1

### Notes:

1. TDK: [www.tdk.com](http://www.tdk.com)
2. AVX: [www.avx.com](http://www.avx.com)
3. Murata: [www.murata.com](http://www.murata.com)
4. Vishay: [www.vishay.com](http://www.vishay.com)
5. Seoul Semi: <http://www.acriche.com/en>
6. Micrel, Inc.: [www.micrel.com](http://www.micrel.com)

# Layout Recommendations

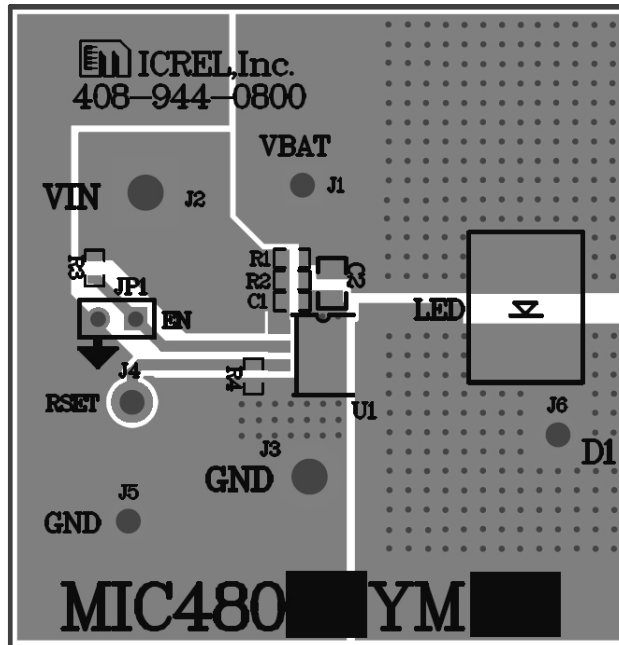

Top Layer

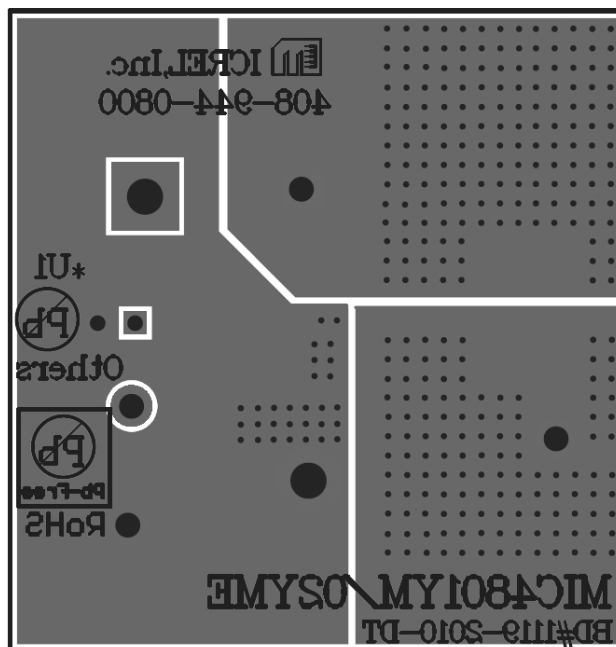

Bottom Layer

Package Information

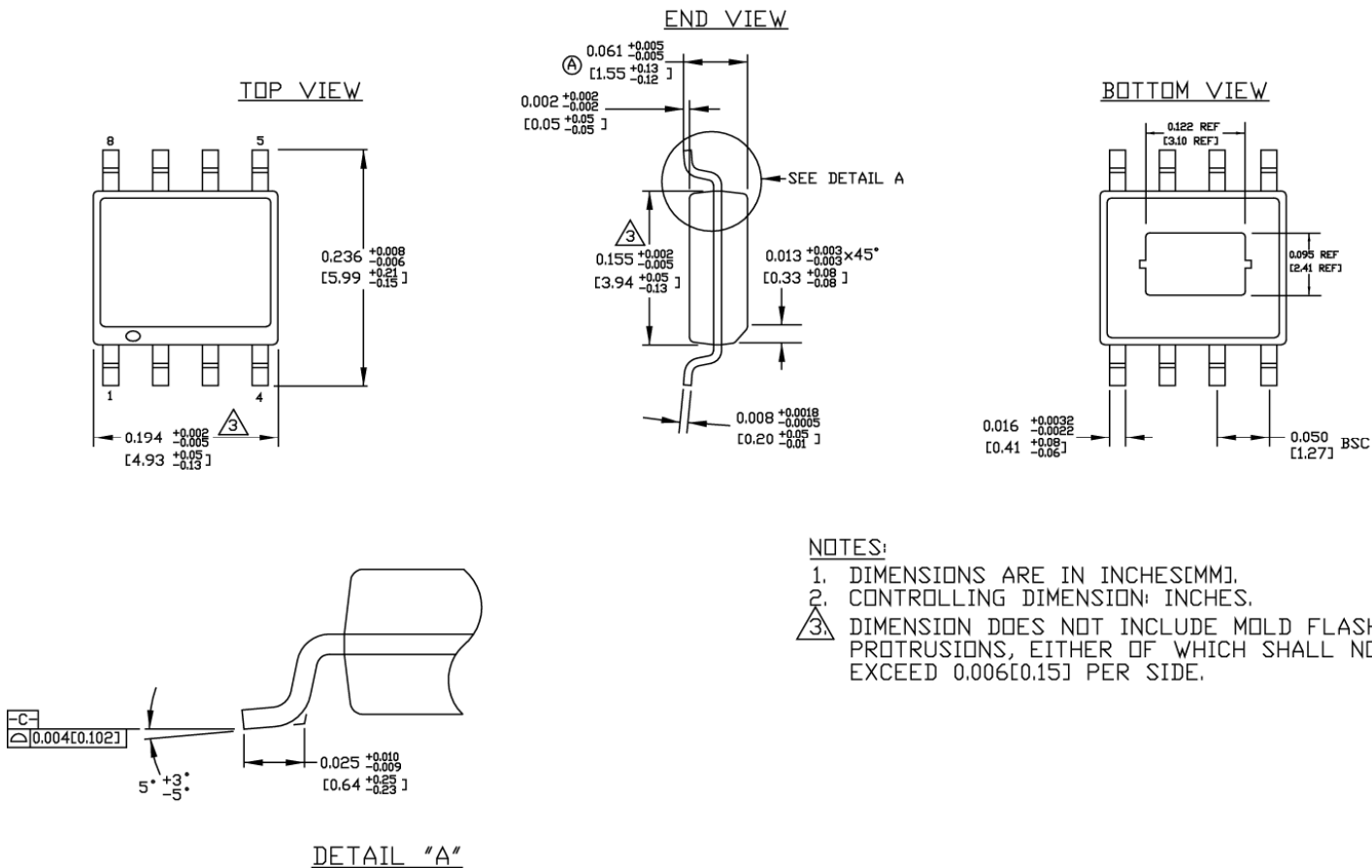

- NOTES:**
1. DIMENSIONS ARE IN INCHES[MM].
  2. CONTROLLING DIMENSION: INCHES.
  3. DIMENSION DOES NOT INCLUDE MOLD FLASH OR PROTRUSIONS, EITHER OF WHICH SHALL NOT EXCEED 0.006[0.15] PER SIDE.

8-Pin SOIC (ME)

**MICREL, INC. 2180 FORTUNE DRIVE SAN JOSE, CA 95131 USA**  
 TEL +1 (408) 944-0800 FAX +1 (408) 474-1000 WEB <http://www.micrel.com>

Micrel makes no representations or warranties with respect to the accuracy or completeness of the information furnished in this data sheet. This information is not intended as a warranty and Micrel does not assume responsibility for its use. Micrel reserves the right to change circuitry, specifications and descriptions at any time without notice. No license, whether express, implied, arising by estoppel or otherwise, to any intellectual property rights is granted by this document. Except as provided in Micrel's terms and conditions of sale for such products, Micrel assumes no liability whatsoever, and Micrel disclaims any express or implied warranty relating to the sale and/or use of Micrel products including liability or warranties relating to fitness for a particular purpose, merchantability, or infringement of any patent, copyright or other intellectual property right.

Micrel Products are not designed or authorized for use as components in life support appliances, devices or systems where malfunction of a product can reasonably be expected to result in personal injury. Life support devices or systems are devices or systems that (a) are intended for surgical implant into the body or (b) support or sustain life, and whose failure to perform can be reasonably expected to result in a significant injury to the user. A Purchaser's use or sale of Micrel Products for use in life support appliances, devices or systems is a Purchaser's own risk and Purchaser agrees to fully indemnify Micrel for any damages resulting from such use or sale.

© 2010 Micrel, Incorporated.