



350mA High Efficiency Step Down LED Driver

FEATURES

- LED drive current up to 350mA
- 12V and 24V system compatible
- Handles transients up to 40V
- Single Pin Control and Dimming function
- Power Efficiency up to 94%
- Drives LED strings of up to 20 volts
- Open and short LED protection
- Parallel configuration for higher output current
- RoHS-compliant TSOT-23 5-lead package

APPLICATIONS

- 12V and 24V Lighting Systems
- Automotive and Aircraft Lighting
- General lighting
- High Brightness 350mA LEDs

ORDERING INFORMATION

Part Number	Quantity per Reel	Package Marking
CAT4201TD-GT3	3000	TF

* Plated Finish: NiPdAu

PIN CONFIGURATION

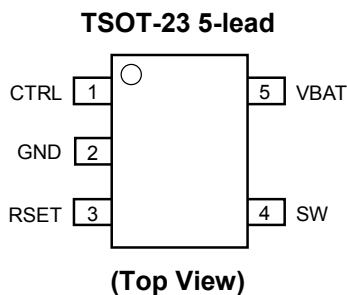

DESCRIPTION

The CAT4201 is a high efficiency step-down converter optimized to drive high current LEDs. A patented switching control algorithm allows highly efficient and accurate LED current regulation. A single RSET resistor sets the full scale LED string current up to 350mA from supplies as high as 28V.

The switching architecture of the CAT4201 results in extremely low internal power dissipation allowing the device to be housed in a tiny package without the need for dedicated heat sinking. The device is compatible with switching frequencies of up to 1MHz, making it ideal for applications requiring small footprint and low value external inductors.

Analog dimming and LED shutdown control is provided via a single input pin, CTRL. Additional features include overload current protection and thermal shutdown. The device is available in the low profile 5-lead thin SOT23 package and is ideal for space constrained applications.

For Ordering Information details, see page 14.

TYPICAL APPLICATION CIRCUIT

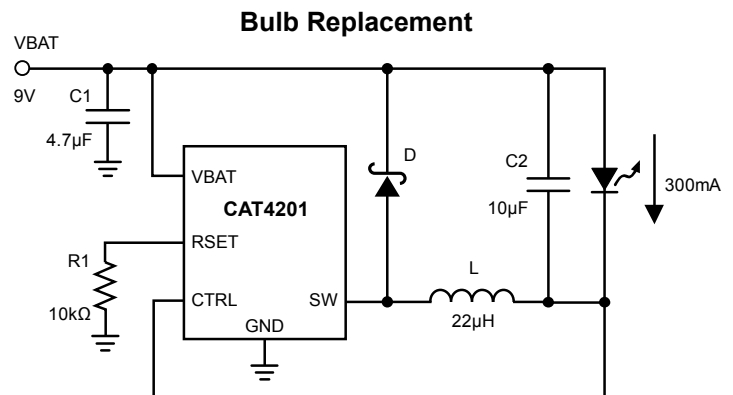

D: Central Schottky CMDSH05-4

L: Sumida CDRH6D26-220

See Table 1 on page 6 for external component selection.

Absolute Maximum Ratings⁽¹⁾

Parameters	Ratings	Units
V _{BAT} , SW, CTRL	-0.3 to +40	V
RSET	-0.3 to +5	V
Switch SW peak current	1	A
Storage Temperature Range	-65 to +160	°C
Junction Temperature Range	-40 to +150	°C
Lead Temperature	300	°C

Recommended Operating Conditions

Parameters	Ratings	Units
V _{BAT} voltage ⁽²⁾⁽³⁾	6.5 to 28 ⁽²⁾	V
SW voltage	0 to 28	V
Ambient Temperature Range	-40 to +125	°C
LED Current	50 to 350	mA
Switching Frequency	50 to 1000	kHz

ELECTRICAL CHARACTERISTICS

V_{IN} = 13V, ambient temperature of 25°C (over recommended operating conditions unless specified otherwise)

Symbol	Parameter	Conditions	Min	Typ	Max	Units
I _Q	Operating Supply Current on V _{BAT} pin			0.4	1	mA
I _{SD}	Idle Mode Supply Current on V _{BAT} pin	CTRL = GND		90		µA
V _{FB}	RSET Pin Voltage	2 LEDs with I _{LED} = 300mA	1.15	1.2	1.25	V
I _{LED}	Programmed LED Current	R1 = 33kΩ R1 = 10kΩ R1 = 8.25kΩ	270	100 300 350	330	mA
V _{CTRL-FULL}	CTRL Voltage for 100% Brightness			2.6	3.1	V
V _{CTRL-EN}	CTRL Voltage to Enable LEDs	LED enable voltage threshold		0.9	1.2	V
V _{CTRL-SD}	CTRL Voltage to Shutdown LEDs	LED disable voltage threshold	0.4	0.9		V
I _{CTRL}	CTRL pin input bias	V _{CTRL} = 3V V _{CTRL} = 12V		40 200	80	µA
R _{SW}	Switch "On" Resistance	I _{SW} = 300mA		0.9	1.5	Ω
T _{SD}	Thermal Shutdown			150		°C
T _{HYST}	Thermal Hysteresis			20		°C
η	Efficiency	Typical Application Circuit		86		%

Notes:

- (1) Stresses above those listed under "Absolute Maximum Ratings" may cause permanent damage to the device. These are stress ratings only, and functional operation of the device at these or any other conditions outside of those listed in the operational sections of this specification is not implied. Exposure to any absolute maximum rating for extended periods may affect device performance and reliability.
- (2) The V_{BAT} pin voltage should be at least 3V greater than the total sum of the LED forward voltages in order to operate at nominal LED current.
- (3) During power-up, the slew rate of the input supply should be greater than 5µs.

Typical Operation Characteristics

$V_{IN} = 13V$, $I_{LED} = 300mA$, $L = 22\mu H$, $C_1 = 4.7\mu F$, $C_2 = 10\mu F$, $T_{AMB} = 25^\circ C$ unless otherwise specified

Input Operating Supply Current

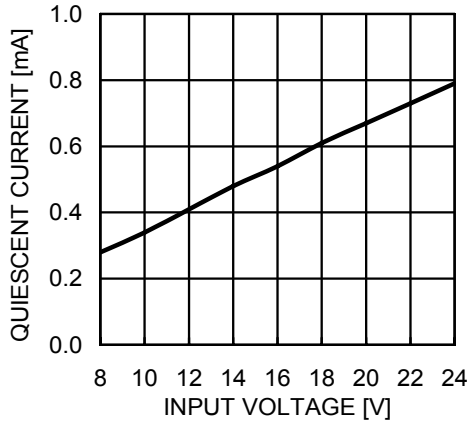

Idle Mode Supply Current (CTRL = 0V)

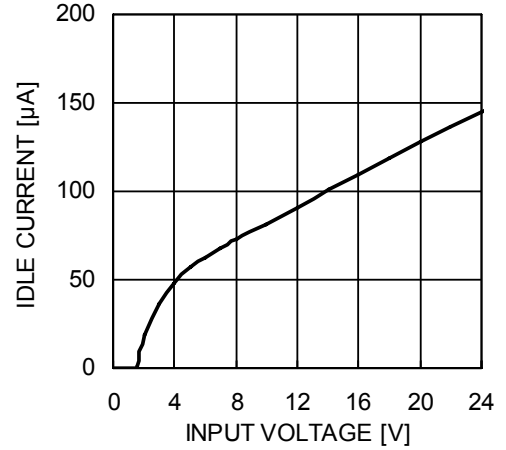

CTRL Input Bias Current

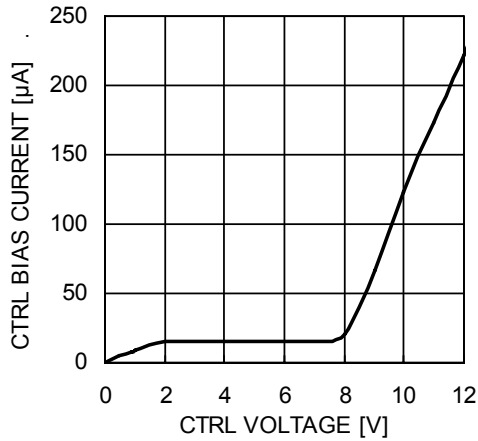

RSET Voltage vs. Temperature

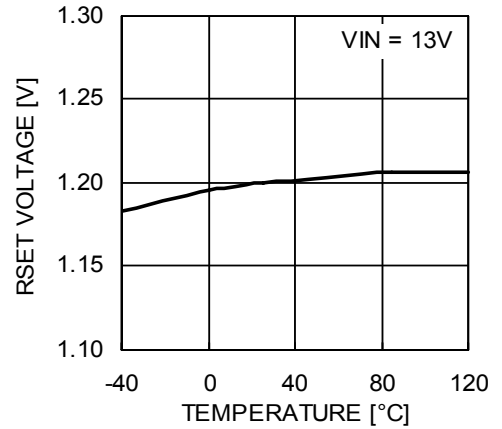

RSET Voltage vs. CTRL Voltage

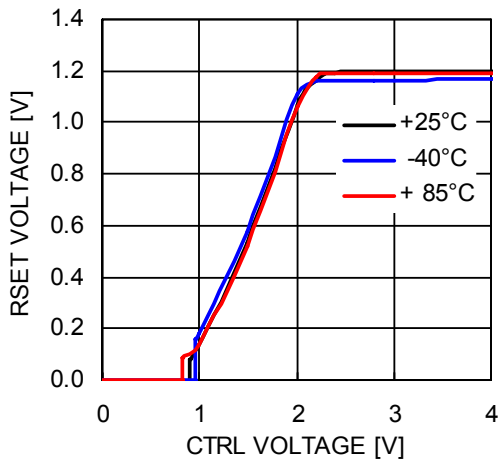

LED Current vs. RSET

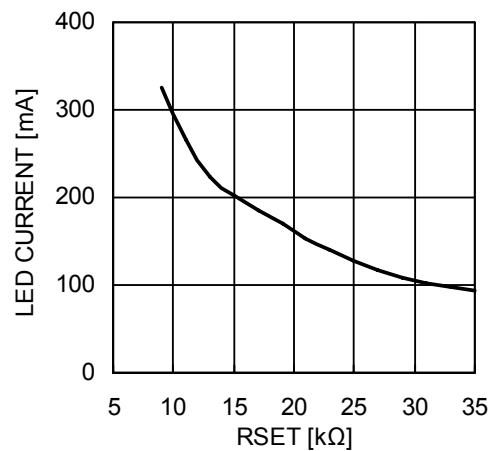

CAT4201

Typical Operation Characteristics

$V_{IN} = 13V$, $I_{LED} = 300mA$, $L = 22\mu H$, $C_1 = 4.7\mu F$, $C_2 = 10\mu F$, $T_{AMB} = 25^\circ C$ unless otherwise specified

Switching Frequency vs. Input Voltage (1 LED)

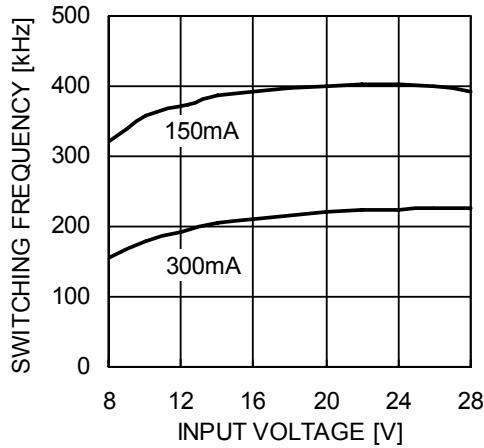

Switching Frequency vs. Input Voltage (2 LEDs)

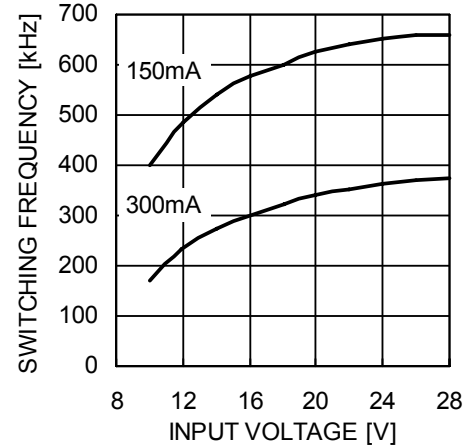

Switching Frequency vs. Temperature

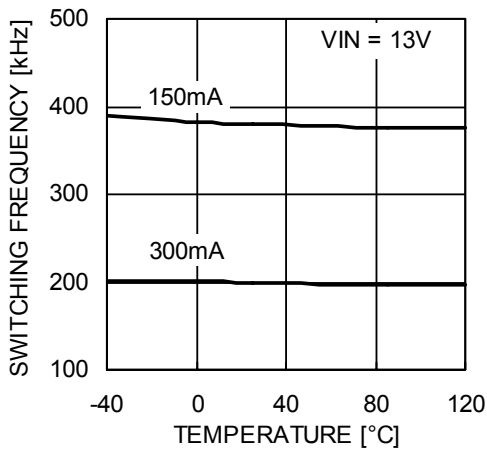

Switch ON Resistance vs. Input Voltage

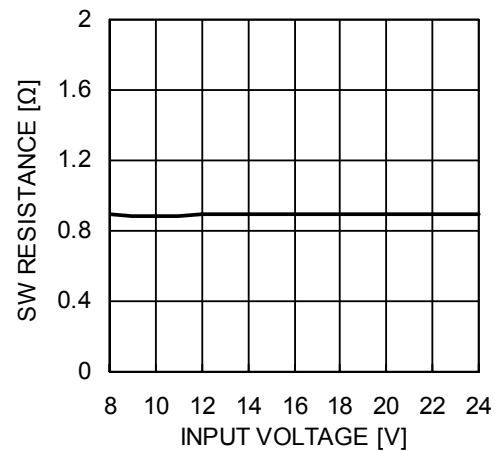

Efficiency vs. Input Voltage (1 LED)

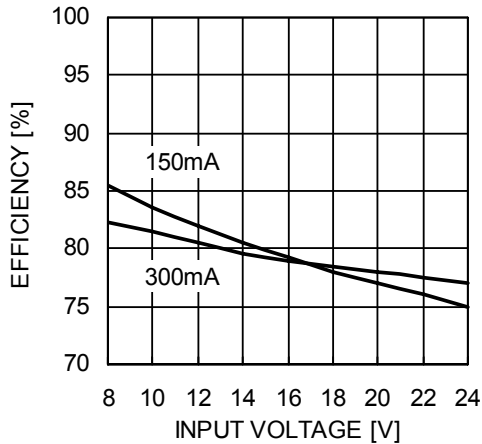

Efficiency vs. Input Voltage (2 LEDs)

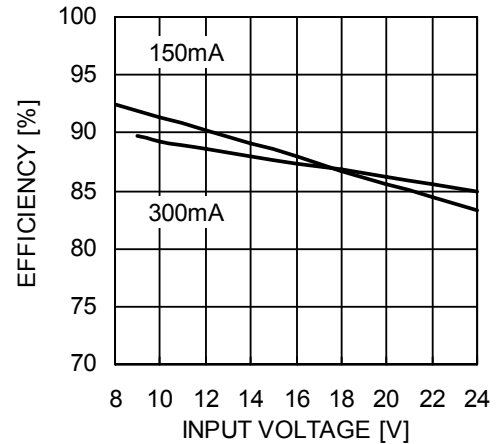

Typical Operation Characteristics

$V_{IN} = 13V$, $I_{LED} = 300mA$, $L = 22\mu H$, $C_1 = 4.7\mu F$, $C_2 = 10\mu F$, $T_{AMB} = 25^\circ C$ unless otherwise specified

Efficiency vs. LED Current

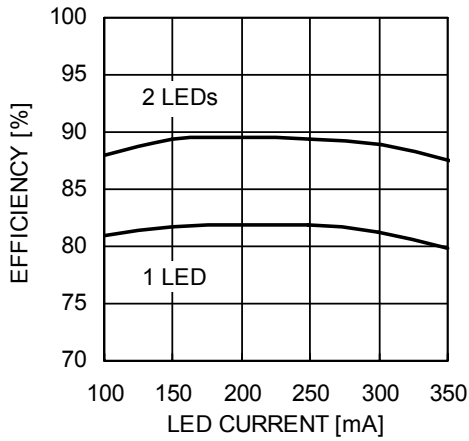

LED Current Regulation vs. Temperature

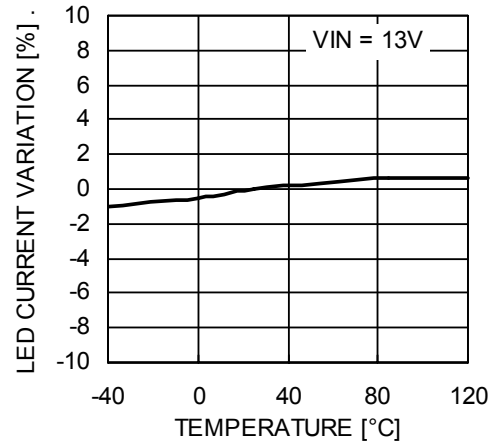

LED Current vs. Input Voltage (1 LED)

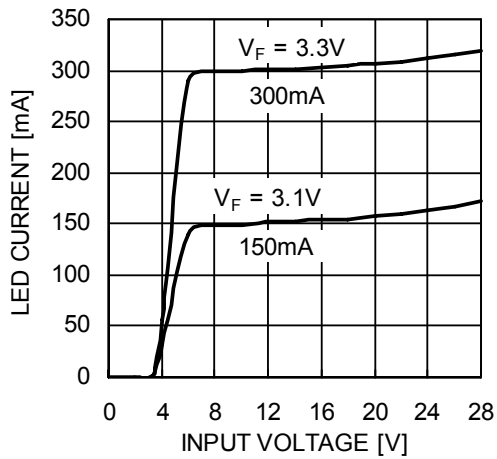

LED Current vs. Input Voltage (2 LEDs)

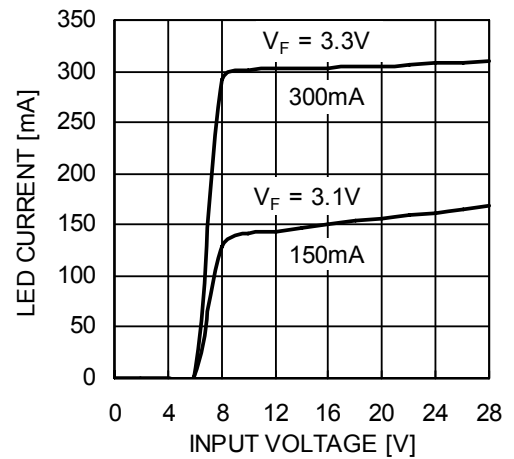

Switching Waveforms

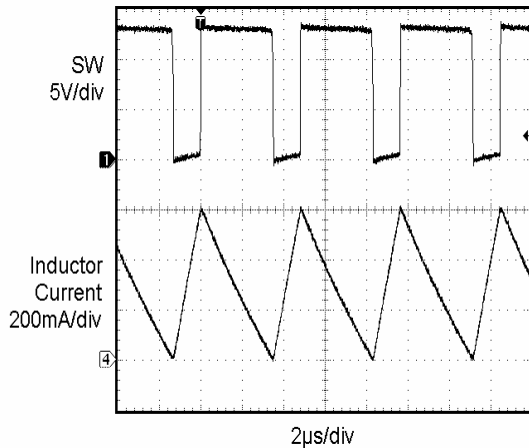

CTRL Power-up

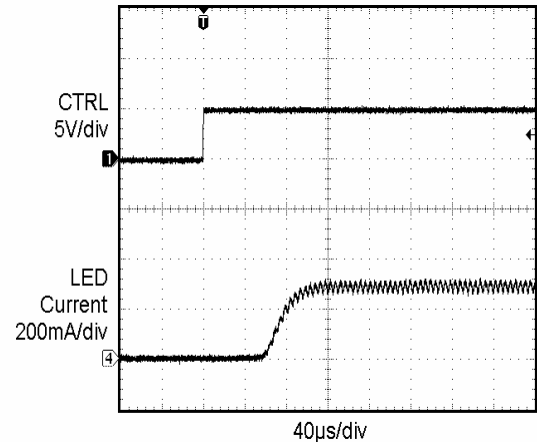

CAT4201

Typical Operation Characteristics

$V_{IN} = 13V$, $I_{LED} = 300mA$, $L = 22\mu H$, $C_1 = 4.7\mu F$, $C_2 = 10\mu F$, $T_{AMB} = 25^\circ C$ unless otherwise specified

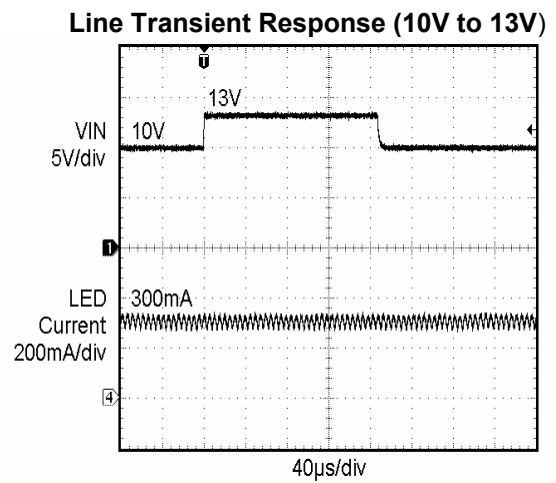
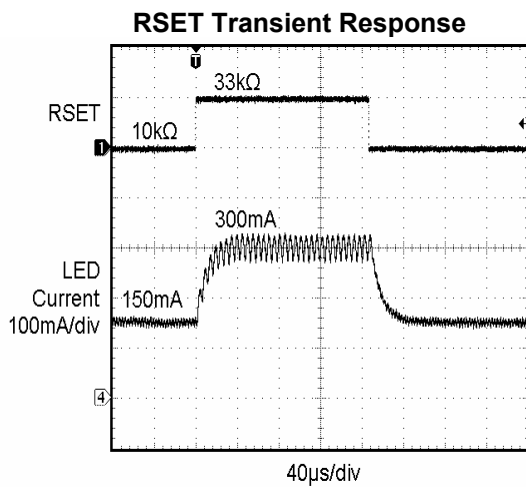

External Component Selection

Table 1 provides the recommended external components L and C2 that offer the best performance

relative to the LED current accuracy, LED ripple current, switching frequency and component size.

LED current (mA)	1 LED		2 LEDs	
	L inductor (µH)	C2 Capacitor (µF)	L inductor (µH)	C2 Capacitor (µF)
≥150	10	2.2	22	4.7
	22	4.7		
< 150	33	4.7	47	2.2
	47	10		

Table 1. External Component Selection

Note: Larger C2 capacitor values allow to reduce further the LED ripple current if needed.

PIN DESCRIPTION

Pin	Name	Function
1	CTRL	Analog dimming control and shutdown pin.
2	GND	Ground reference.
3	RSET	RSET pin. A resistor connected between the pin and ground sets the average LED current.
4	SW	Interface to the inductor.
5	VBAT	Supply voltage for the device.

PIN FUNCTION

VBAT is the supply input to the device. Typical current conduction into this pin is less than 1mA and voltage transients of up to 40V can be applied. To ensure accurate LED current regulation, the VBAT voltage should be 3V higher than the total forward voltage of the LED string. A bypass capacitor of 4.7 μ F or larger is recommended between VBAT and GND.

CTRL is the analog dimming and control input. An internal pull-down current of 20 μ A allows the LEDs to shutdown if CTRL is left floating. Voltages of up to 40V can be safely handled by the CTRL input pin.

When the CTRL voltage is less than 0.9V (typ), the LEDs will shutdown to zero current. When the CTRL voltage is greater than about 2.6V, full scale brightness is applied to the LED output. At voltages of less than around 2.6V, the LED current is progressively dimmed until shutdown.

For lamp replacement applications, or applications where operation in dropout mode is expected, it is recommended that the CTRL pin voltage be derived from the LED cathode terminal.

GND is the ground reference pin. This pin should be connected directly to the ground plane on the PCB.

SW pin is the drain terminal of the internal low resistance high-voltage power MOSFET. The inductor and the Schottky diode anode should be connected to the SW pin. Voltages of up to 40V can be safely handled on the SW pin. Traces going to the SW pin should be as short as possible with minimum loop area. The device can handle safely “open-LED” or “shorted-LED” fault conditions.

RSET pin is regulated at 1.2V. A resistor connected between the RSET pin and ground sets the LED full-scale brightness current. The external resistance value and the CTRL pin voltage determine the LED current during analog dimming.

SIMPLIFIED BLOCK DIAGRAM

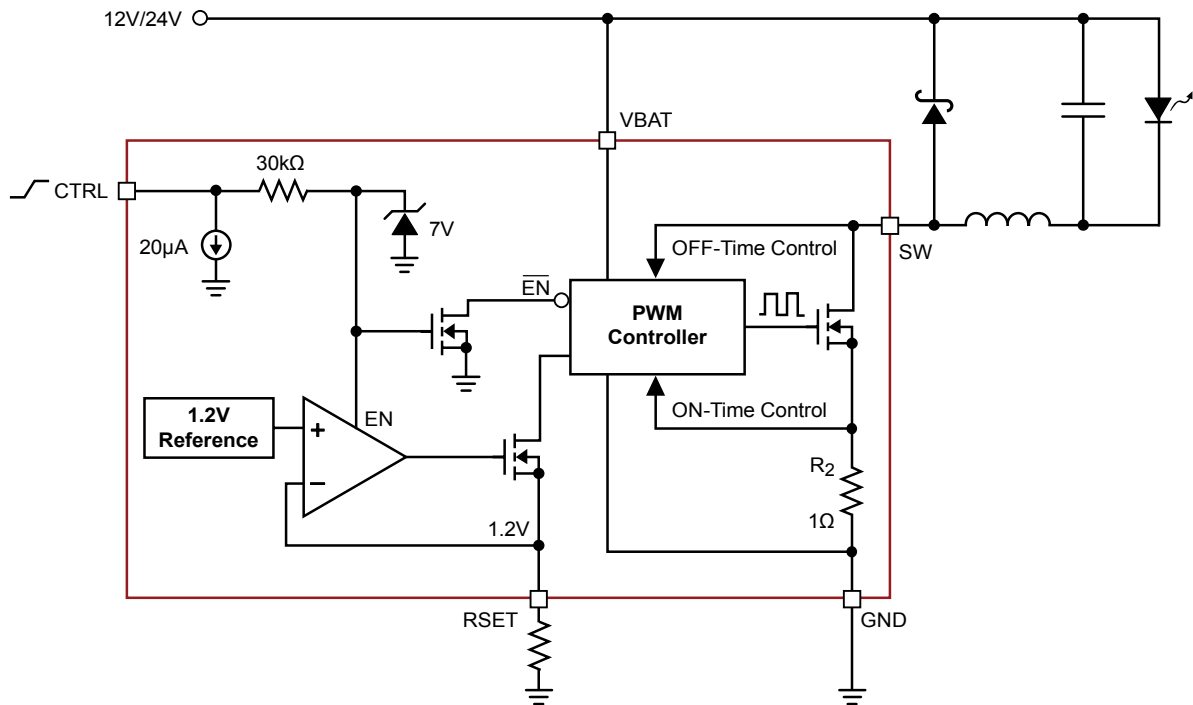

Figure 1. CAT4201 Simplified Block Diagram

BASIC OPERATION

The CAT4201 is a high efficiency step-down regulator designed to drive series connected high-power LEDs. LED strings with total forward voltages of up to 20V can be driven with bias currents of up to 350mA.

During the first switching phase, an integrated high voltage power MOSFET allows the inductor current to charge linearly until the peak maximum level is reached, at which point the MOSFET is switched off and the second phase commences, allowing the inductor current to then flow through the Schottky diode circuit and discharge linearly back to zero current.

The switching architecture ensures the device will always operate at the cross-over point between Continuous Conduction Mode (CCM) and Discontinuous Conduction Mode (DCM). This operating mode results in an average LED current which is equal to half of the peak switching current.

LED Pin Current

The LED current is set by the external RSET resistor connected to the regulated output of the RSET pin. An overall current gain ratio of approximately 2.5A/mA exists between the average LED current and the RSET current, hence the following equation can be used to calculate the LED current.

$$\text{LED Current (A)} \cong 2.5 \times V_{\text{RSET}} \text{ (V)} / R_{\text{SET}} \text{ (k}\Omega\text{)}$$

Table 2 lists the various LED currents and the associated RSET resistors.

LED current (A)	RSET (kΩ)
0.10	33
0.15	21
0.20	15
0.25	12
0.30	10
0.35	8.25

Table 2. RSET Resistor Selection

APPLICATION INFORMATION

Input Voltage Range

The minimum supply voltage required to maintain adequate regulation is set by the cathode terminal voltage of the LED string (i.e the VBAT voltage minus the LED string voltage). When the LED cathode terminal falls below 3V, a loss of regulation occurs.

For applications which may occasionally need to experience supply “dropout” conditions, it is recommended that the CTRL input be used to sense the LED cathode voltage. The CTRL pin can either be tied directly to the cathode terminal (for Lamp Replacement) or connected via a pass-transistor for PWM lighting applications.

Figure 2 shows the regulation performance obtained in dropout, when the CTRL pin is configured to sense the LED cathode voltage.

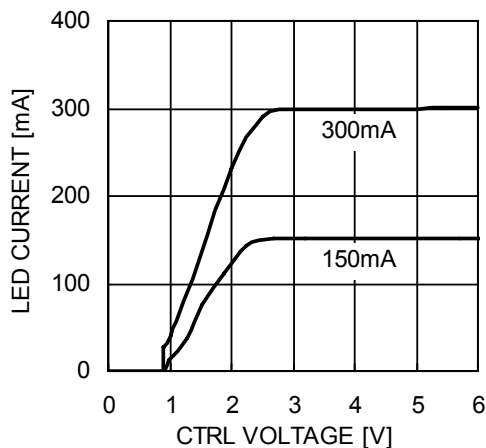

Figure 2. “Dropout” configured LED Current
(as shown in Typical Application on page 1)

Inductor Selection

For 350mA LED current drive levels, a 22 μ H inductor value is recommended to provide suitable switching frequency across a wide range of input supply values. For LED current of 150mA or less, a 33 μ H or 47 μ H inductor is more suitable.

The inductor must have a maximum current rating which equals or exceeds twice the programmed LED current. For example, when driving LEDs at 350mA, an inductor with at least 700mA current rating must be used. Minor improvements in efficiency can be achieved by selecting inductors with lower series resistance.

Part Number	L (μ H)	I rated (A)	LED current (A)
CDRH6D26-100	10	1.5	0.35
CDRH6D26-220	22	1.0	0.35
CDRH6D28-330	33	0.92	0.35
CDRH6D28-470	47	0.8	0.35
CDRH6D28-560	56	0.73	0.35

Table 3. Sumida inductors

Capacitor Selection

A 10 μ F ceramic capacitor C2 across the LED(s) keeps the LED ripple current within $\pm 15\%$ of nominal for most applications. If needed, a larger capacitor can be used to further reduce the LED current ripple. Any resistance in series with the LED (0.5 Ω or more) contributes to reduce the ripple current. The capacitor voltage rating should be equivalent to the maximum expected supply voltage so as to allow for “Open-LED” fault conditions. The capacitor value is independent of the switching frequency or the overall efficiency.

A 4.7 μ F ceramic input capacitor C1 is recommended to minimize the input current ripple generated on the supply. Using a larger capacitor value further reduces the ripple noise appearing on the supply rail.

If a constant capacitance is needed across temperature and voltage, X5R or X7R dielectric capacitors are recommended.

Schottky Diode

The peak repetitive current rating of the Schottky diode must be greater than the peak current flowing through the inductor. Also the continuous current rating of the Schottky must be greater than the average LED current. The voltage rating of the diode should be greater than the peak supply voltage transient preventing any breakdown or leakage. Central Semiconductor Schottky diode CMDSH05-4 (40V, 500mA rated) is recommended. Schottky diodes rated at 400mA (or higher) continuous current are fine for most applications.

Note: Schottky diodes with extremely low forward voltages (V_F) are not recommended, as they may cause an increase in the LED current.

CAT4201

Dimming Methods

Two methods for PWM dimming control on the LEDs are described below. The first method is to PWM on the control pin, the other method is to turn on and off a second resistor connected to the RSET pin and connected in parallel with R1.

PWM on CTRL Pin

A PWM signal from a microprocessor can be used for dimming the LEDs when tied to the CTRL pin. The duty cycle which is the ratio between the On time and the total cycle time sets the dimming factor. The recommended PWM frequency on the CTRL pin is between 100Hz and 2kHz.

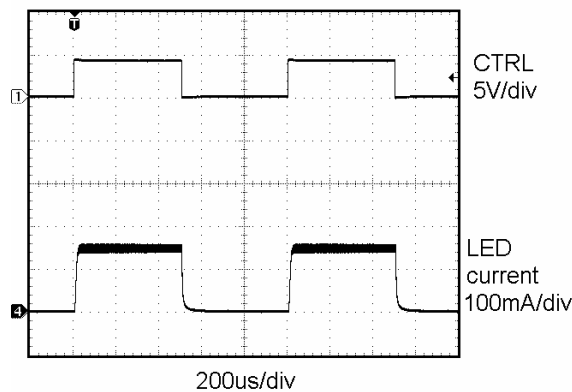

Figure 3. PWM at 1kHz on CTRL Pin

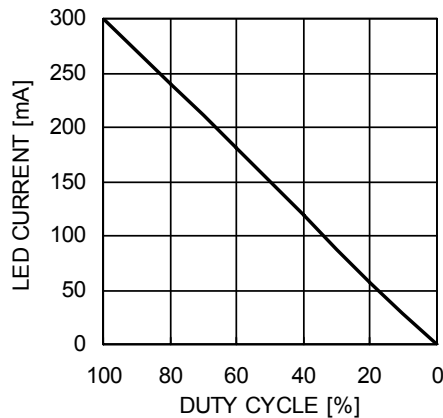

Figure 4. LED Current vs. Duty Cycle

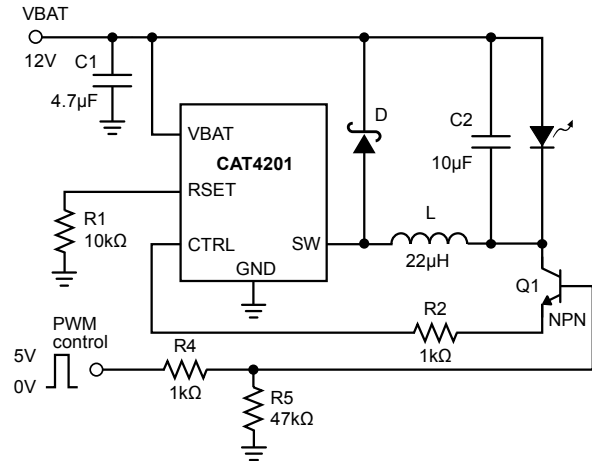

Figure 5. Circuit for PWM on CTRL

PWM on RSET Pin

Another dimming method is to place in parallel to R1 another resistor with a FET in series, as shown on Figure 6. R1 sets the minimum LED current corresponding to 0% duty cycle. The combined resistor of R1 and Rmax sets the maximum LED current corresponding to 100% duty cycle.

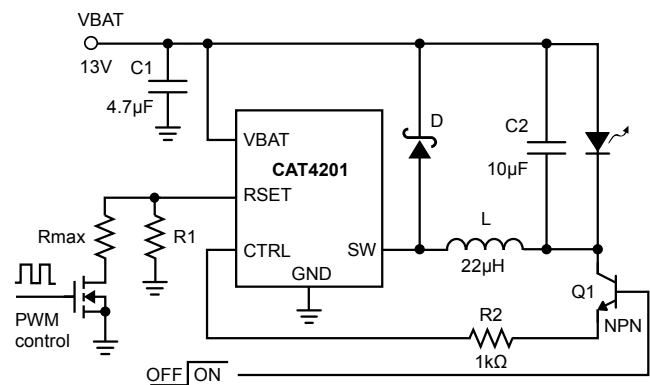

Figure 6. Circuit for PWM on RSET

Operation from high supply voltage above 14V

It is recommended to have a slew rate of 5μs or more for applications with supply voltages of 14V and above. When using a high supply voltage of 24V, a 1Ω or 2Ω resistor in series with the supply, as shown on Figure 7, is recommended to limit the slew rate of the supply voltage. A 4.7μF minimum ceramic capacitor is placed between the VBAT pin and ground. The combination of the series resistor R3 and input capacitor C1 acts as a low pass filter limiting the excessive in-rush currents and overvoltage transients which would otherwise occur during “hot-plug” conditions, thereby protecting the CAT4201 driver.

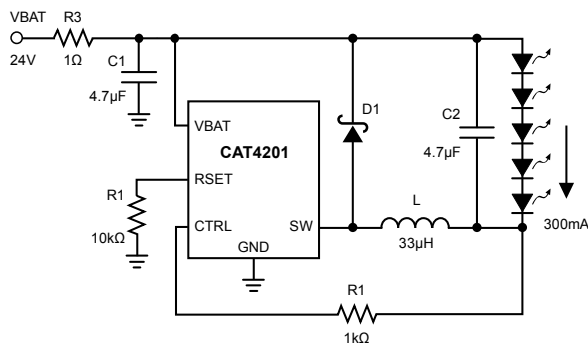

Figure 7. 24V Application with 5 LEDs

Parallel configuration for driving LEDs beyond 350mA

Several CAT4201 devices can be connected in parallel for driving LEDs with current in excess of 350mA. The CAT4201 driver circuits are connected to the same LED cathode. Figure 8 shows the application schematic for driving 1A into one LED with three CAT4201 connected in parallel. Each CAT4201 is driving the LED with a current set by its RSET resistor. The resulting LED current is equal to the sum of each driver current.

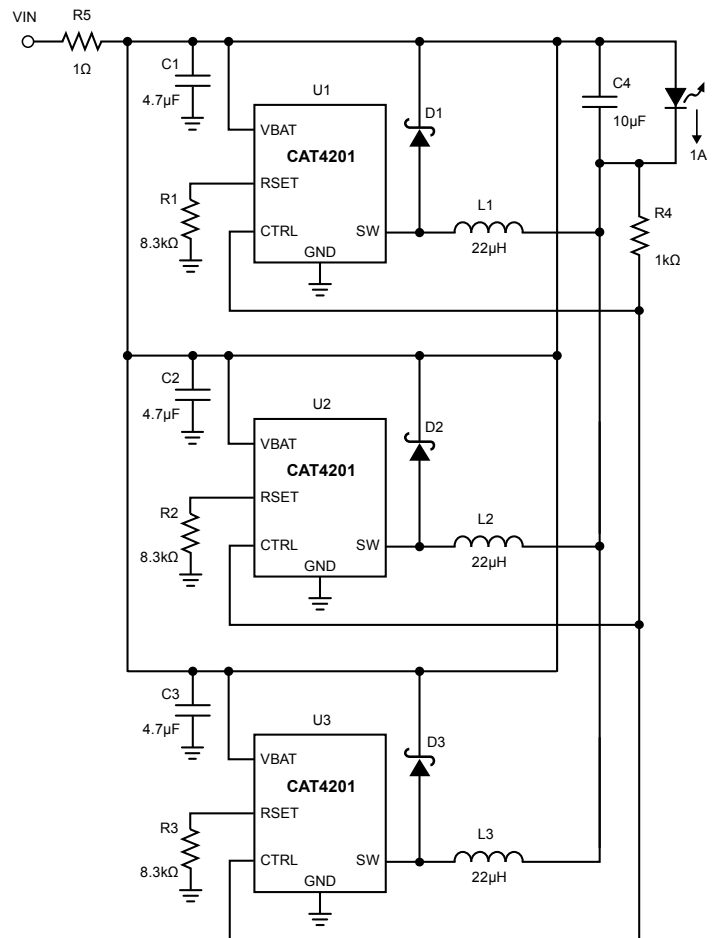

Figure 8. Three CAT4201 in Parallel for 1A LED

CAT4201

Open LED Behavior

If the LEDs are not connected, the CAT4201 stops switching and draws very little current.

At power-up with no load connected, the capacitor C2 is charged-up by the CAT4201. As soon as the bottom side of the capacitor (C2-) reaches 0 volt, as shown on Figure 9, the CAT4201 stops switching and remains in the idle mode only drawing about 0.4mA current from the supply.

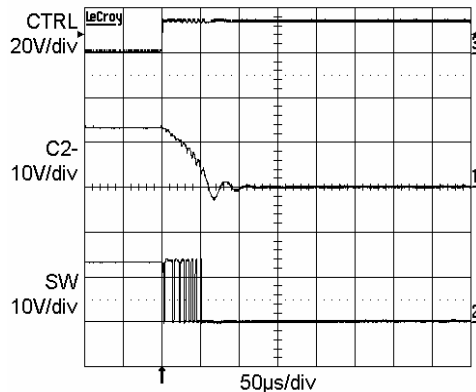

Figure 9. Open LED mode

Board Layout

In order to minimize EMI and switching noise, the Schottky diode, the inductor and the output capacitor C2 should all be located close to the driver IC. The input capacitor C1 should be located close to the VBAT pin and the Schottky diode cathode. The CAT4201 ground pin should be connected directly to the ground plane on the PCB. A recommended PCB layout with component location is shown on Figure 10. The LEDs are connected by two wires tied to both sides of the output capacitor C2. The LEDs can be located away from the driver if needed.

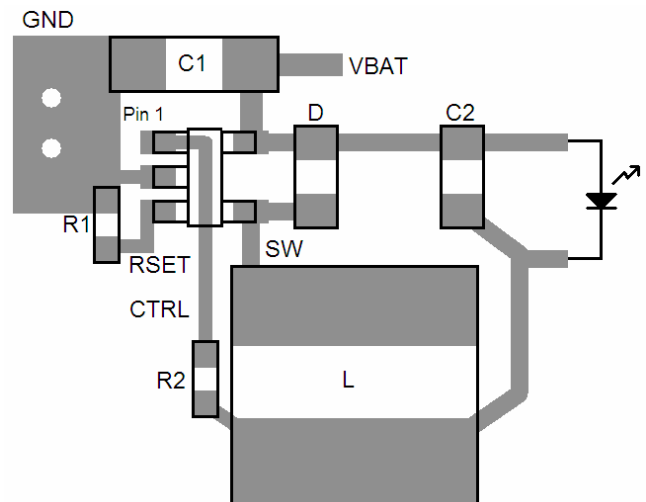
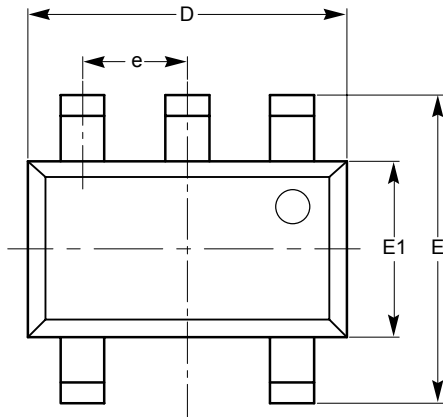

Figure 10. Recommended PCB Layout

In order to further reduce the ripple on the supply rail, an optional Pi style filter (C-L-C) can be used. A 10µH inductor rated to the maximum supply current can be used.

PACKAGE OUTLINE DRAWING

TSOT-23 5-Lead (TD)⁽¹⁾⁽²⁾



TOP VIEW

SYMBOL	MIN	NOM	MAX
A			1.00
A1	0.01	0.05	0.10
A2	0.80	0.87	0.90
b	0.30		0.45
c	0.12	0.15	0.20
D	2.90 BSC		
E	2.80 BSC		
E1	1.60 BSC		
e	0.95 TYP		
L	0.30	0.40	0.50
L1	0.60 REF		
L2	0.25 BSC		
θ	0°		8°

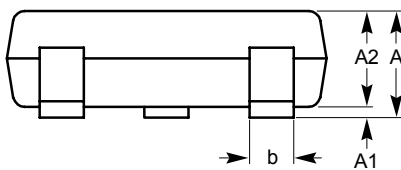

SIDE VIEW

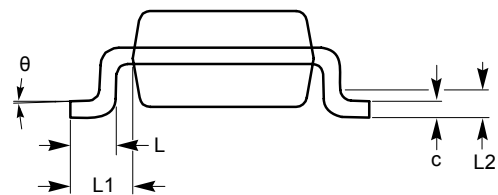

END VIEW

For current Tape and Reel information, download the PDF file from:
<http://www.catsemi.com/documents/tapeandreel.pdf>.

Notes:

- (1) All dimensions are in millimeters. Angles in degrees.
- (2) Complies with JEDEC standard MO-193.

EXAMPLE OF ORDERING INFORMATION

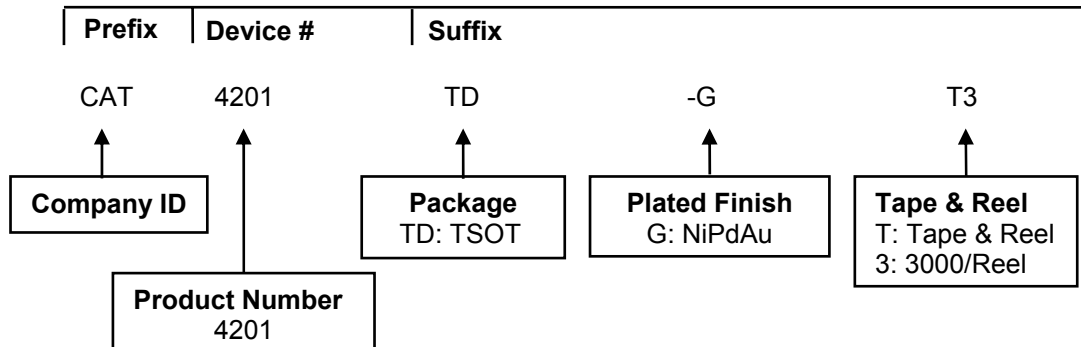

ORDERING PART NUMBER
CAT4201TD-GT3

Notes:

- (1) All packages are RoHS-compliant (Lead-free, Halogen-free).
- (2) The standard plated finish is NiPdAu on all pins.
- (3) The device used in the above example is a CAT4201TD-GT3 (TSOT-23, NiPdAu, Tape & Reel).
- (4) For additional package and temperature options, please contact your nearest Catalyst Semiconductor Sales office.

REVISION HISTORY

Date	Rev.	Reason
07/24/07	A	Initial Issue
08/02/07	B	Updated Typical Application Circuit Added "External Component Selection" Table Added "Capacitor Selection" information Updated Figures 5, 6, 7, 8
02/21/08	C	Update Description, change patent-pending to patented Update Package Outline Drawing

Copyrights, Trademarks and Patents

© Catalyst Semiconductor, Inc.

Trademarks and registered trademarks of Catalyst Semiconductor include each of the following:

Adaptive Analog™, Beyond Memory™, DPP™, EZDim™, LDD™, MiniPot™, Quad-Mode™ and Quantum Charge Programmable™

Catalyst Semiconductor has been issued U.S. and foreign patents and has patent applications pending that protect its products.

CATALYST SEMICONDUCTOR MAKES NO WARRANTY, REPRESENTATION OR GUARANTEE, EXPRESS OR IMPLIED, REGARDING THE SUITABILITY OF ITS PRODUCTS FOR ANY PARTICULAR PURPOSE, NOR THAT THE USE OF ITS PRODUCTS WILL NOT INFRINGE ITS INTELLECTUAL PROPERTY RIGHTS OR THE RIGHTS OF THIRD PARTIES WITH RESPECT TO ANY PARTICULAR USE OR APPLICATION AND SPECIFICALLY DISCLAIMS ANY AND ALL LIABILITY ARISING OUT OF ANY SUCH USE OR APPLICATION, INCLUDING BUT NOT LIMITED TO, CONSEQUENTIAL OR INCIDENTAL DAMAGES.

Catalyst Semiconductor products are not designed, intended, or authorized for use as components in systems intended for surgical implant into the body, or other applications intended to support or sustain life, or for any other application in which the failure of the Catalyst Semiconductor product could create a situation where personal injury or death may occur.

Catalyst Semiconductor reserves the right to make changes to or discontinue any product or service described herein without notice. Products with data sheets labeled "Advance Information" or "Preliminary" and other products described herein may not be in production or offered for sale.

Catalyst Semiconductor advises customers to obtain the current version of the relevant product information before placing orders. Circuit diagrams illustrate typical semiconductor applications and may not be complete.



Catalyst Semiconductor, Inc.

Corporate Headquarters

2975 Stender Way

Santa Clara, CA 95054

Phone: 408.542.1000

Fax: 408.542.1200

www.catsemi.com

Document No: MD-5025

Revision: C

Issue date: 02/21/08