

Features

- **Advanced performance**
- **High sensitivity**
- **Symmetrical thresholds**
- **High piezo resistivity**
- **Reduced power consumption**
- **South and north pole pre-induction possible**
- AC coupled
- Digital output signal
- Two-wire and three-wire configuration possible
- Large temperature range
- Large airgap
- Low cut-off frequency
- Protection against overvoltage
- Protection against reversed polarity
- Output protection against electrical disturbances

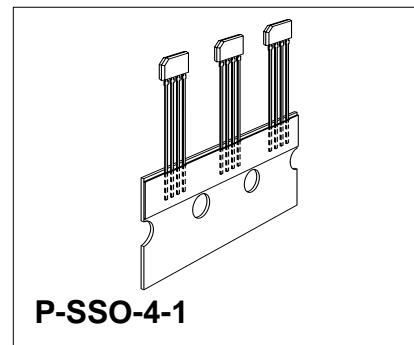

Type	Marking	Ordering Code	Package
TLE 4921-3U	21C3U	Q67006-A9171	P-SSO-4-1

The differential Hall Effect sensor TLE 4921-3U provides a high sensitivity and a superior stability over temperature and symmetrical thresholds in order to achieve a stable duty cycle. TLE 4921-3U is particularly suitable for rotational speed detection and timing applications of ferromagnetic toothed wheels such as anti-lock braking systems, transmissions, crankshafts, etc. The integrated circuit (based on Hall effect) provides a digital signal output with frequency proportional to the speed of rotation. Unlike other rotational sensors differential Hall ICs are not influenced by radial vibration within the effective airgap of the sensor and require no external signal processing.

Pin Configuration

(view on branded side of component)

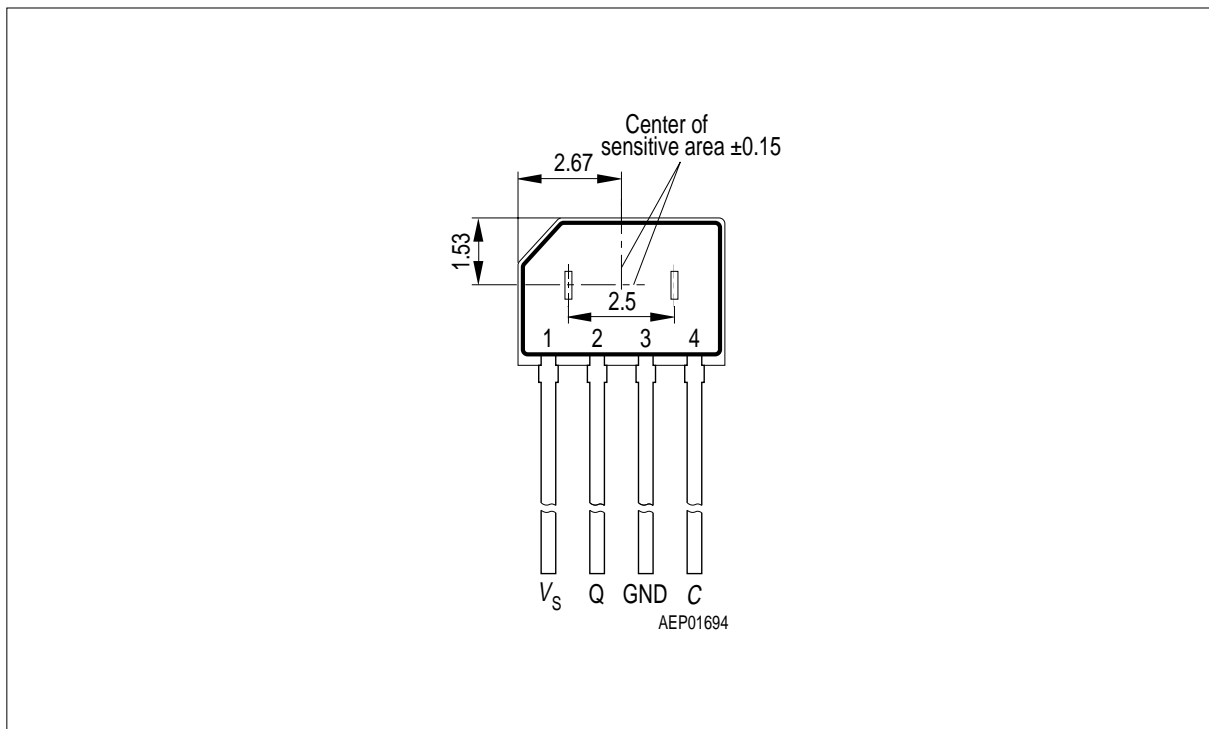

Figure 1

Pin Definitions and Functions

Pin No.	Symbol	Function
1	V_S	Supply voltage
2	Q	Output
3	GND	Ground
4	C	Capacitor

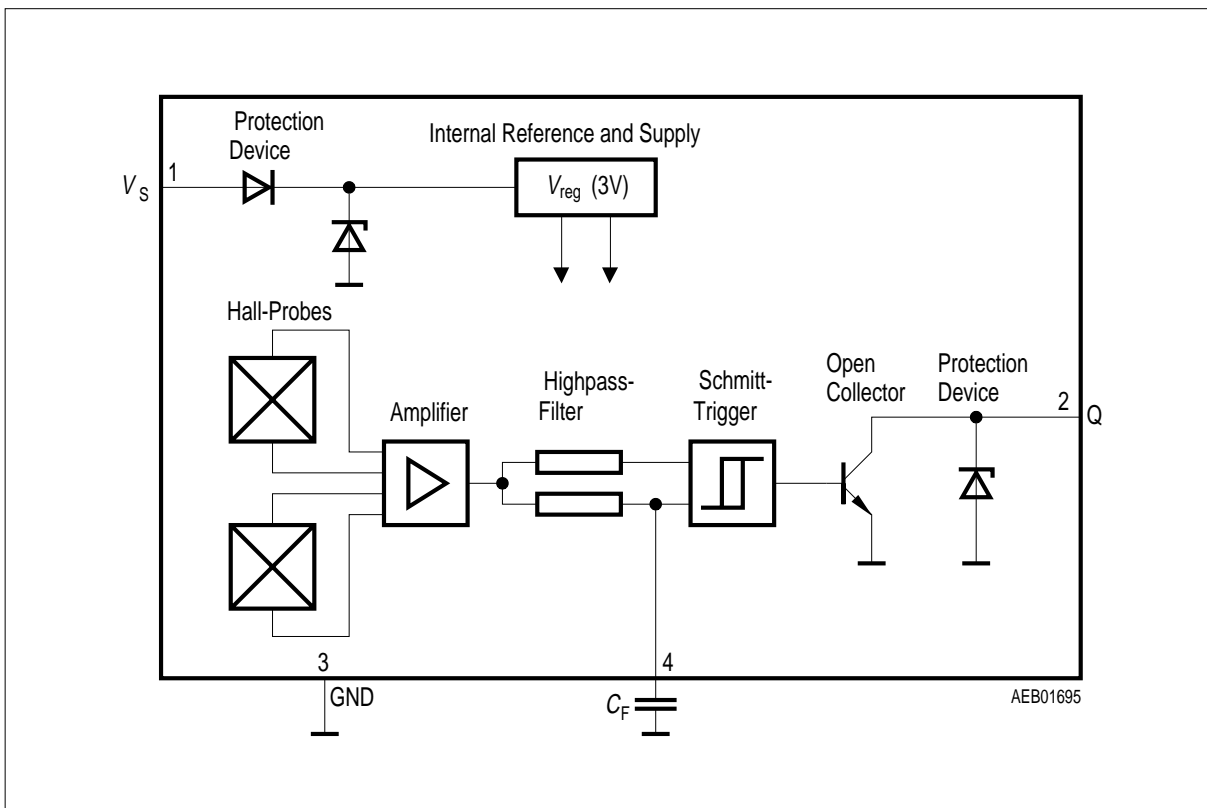

Figure 2 Block Diagram

Functional Description

The Differential Hall Sensor IC detects the motion and position of ferromagnetic and permanent magnet structures by measuring the differential flux density of the magnetic field. To detect ferromagnetic objects the magnetic field must be provided by a back biasing permanent magnet (**south or north** pole of the magnet attached to the rear unmarked side of the IC package).

Using an external capacitor the generated Hall voltage signal is slowly adjusted via an active high pass filter with a low cut-off frequency. This causes the output to switch into a biased mode after a time constant is elapsed. The time constant is determined by the external capacitor. Filtering avoids aging and temperature influence from Schmitt-trigger input and eliminates device and magnetic offset.

The TLE 4921-3U can be exploited to detect toothed wheel rotation in a rough environment. Jolts against the toothed wheel and ripple have no influence on the output signal.

Furthermore, the TLE 4921-3U can be operated in a two-wire as well as in a three-wire-configuration.

The output is logic compatible by high/low levels regarding on and off.

Circuit Description (see Figure 2)

The TLE 4921-3U is comprised of a supply voltage reference, a pair of Hall probes spaced at 2.5 mm, differential amplifier, filter for offset compensation, Schmitt trigger, and an open collector output.

The TLE 4921-3U was designed to have a wide range of application parameter variations. Differential fields up to ± 80 mT can be detected without influence to the switching performance. The pre-induction field can either come from a magnetic south or north pole, whereby the field strength up to 500 mT or more will not influence the switching points. The improved temperature compensation enables a superior sensitivity and accuracy over the temperature range. Finally the optimized piezo compensation and the integrated dynamic offset compensation enable easy manufacturing and elimination of magnet offsets.

Protection is provided at the input/supply (pin 1) for overvoltage and reverse polarity and against overstress such as load dump, etc., in accordance with ISO-TR 7637 and DIN 40839. The output (pin 2) is protected against voltage peaks and electrical disturbances.

Absolute Maximum Ratings
 $T_j = -40$ to 150 °C

Parameter	Symbol	Limit Values		Unit	Remarks
		min.	max.		
Supply voltage	V_S	$-35^{1)}$	30	V	–
Output voltage	V_Q	-0.7	30	V	–
Output current	I_Q	–	50	mA	–
Output reverse current	$-I_Q$	–	50	mA	–
Capacitor voltage	V_C	-0.3	3	V	–
Junction temperature	T_j	–	150	°C	5000 h
Junction temperature	T_j	–	160	°C	2500 h
Junction temperature	T_j	–	170	°C	1000 h
Junction temperature	T_j	–	210	°C	40 h
Storage temperature	T_S	-40	150	°C	–
Thermal resistance P-SSO-4-1	$R_{th JA}$	–	190	K/W	–
Current through input- protection device	I_{SZ}	–	200	mA	$t < 2$ ms; $v = 0.1$
Current through output- protection device	I_{QZ}	–	200	mA	$t < 2$ ms; $v = 0.1$

Electro Magnetic Compatibility

ref. DIN 40839 part 1; test circuit 1

Testpulse 1	V_{LD}	-100		V	$t_d = 2$ ms
Testpulse 2	V_{LD}		100	V	$t_d = 0.05$ ms
Testpulse 3a	V_{LD}	-150		V	$t_d = 0.1$ μ s
Testpulse 3b	V_{LD}		100	V	$t_d = 0.1$ μ s
Testpulse 4	V_{LD}	-7		V	$t_d \leq 20$ s
Testpulse 5	V_{LD}		120	V	$t_d = 400$ ms; $R_p = 400$ Ω

¹⁾ Reverse current < 10 mA

Note: Stresses above those listed here may cause permanent damage to the device. Exposure to absolute maximum rating conditions for extended periods may affect device reliability.

Operating Range

Parameter	Symbol	Limit Values		Unit	Remarks
		min.	max.		
Supply voltage	V_S	4.5	24	V	–
Junction temperature	T_j	– 40	170	°C	–
Pre-induction	B_0	– 500	500	mT	at Hall probe; independent of magnet orientation
Differential induction	ΔB	– 80	80	mT	–

Note: In the operating range the functions given in the circuit description are fulfilled.

AC/DC Characteristics

Parameter	Symbol	Limit Values			Unit	Test Condition	Test Circuit
		min.	typ.	max.			
Supply current	I_S	4.7	6.1	8.0	mA	$V_Q = \text{high}$ $I_Q = 0 \text{ mA}$	1
		5.1	6.7	8.8	mA	$V_Q = \text{low}$ $I_Q = 40 \text{ mA}$	1
Output saturation voltage	$V_{Q\text{Sat}}$	–	0.25	0.6	V	$I_Q = 40 \text{ mA}$	1
Output leakage current	I_{QL}	–	–	10	μA	$V_Q = 24 \text{ V}$	1
Center of switching points: $(\Delta B_{OP} + \Delta B_{RP}) / 2$	ΔB_m	– 1	0	1	mT	$- 20 \text{ mT} < \Delta B < 20 \text{ mT}$ ^{1) 2)} $f = 200 \text{ Hz}$	2
Operate point	ΔB_{OP}	–	–	0	mT	$f = 200 \text{ Hz}$, $\Delta B = 20 \text{ mT}$	2
Release point	ΔB_{RP}	0	–	–	mT	$f = 200 \text{ Hz}$, $\Delta B = 20 \text{ mT}$	2
Hysteresis	ΔB_{Hy}	0.5	1.5	2.5	mT	$f = 200 \text{ Hz}$, $\Delta B = 20 \text{ mT}$	2
Overvoltage protection at supply voltage at output	V_{SZ}	27	–	35	V	$I_S = 16 \text{ mA}$	1
	V_{QZ}	27	–	35	V	$I_S = 16 \text{ mA}$	1
Output rise time	t_r	–	–	0.5	μs	$I_Q = 40 \text{ mA}$ $C_L = 10 \text{ pF}$	1

AC/DC Characteristics (cont'd)

Parameter	Symbol	Limit Values			Unit	Test Condition	Test Circuit
		min.	typ.	max.			
Output fall time	t_f	–	–	0.5	μs	$I_Q = 40 \text{ mA}$ $C_L = 10 \text{ pF}$	1
Delay time ³⁾	t_{dop}	–	–	25	μs	$f = 10 \text{ kHz}$ $\Delta B = 5 \text{ mT}$	2
	t_{drp}	–	–	10	μs		
	$t_{\text{dop}} - t_{\text{drp}}$	–	0	15	μs		
Filter input resistance	R_C	32	40	48	$\text{k}\Omega$	$25 \text{ }^\circ\text{C} \pm 2 \text{ }^\circ\text{C}$	1
Filter sensitivity to ΔB	S_C	–	– 4	–	mV/mT	–	1
Filter bias voltage	V_C	0.8	–	2.2	V	$\Delta B = 0$	1
Frequency	f	⁴⁾	–	20000	Hz	$\Delta B = 5 \text{ mT}$	2
Resistivity against mechanical stress (piezo)	ΔB_m	– 0.1	–	0.1	mT	$F = 2 \text{ N}$	2 ⁵⁾
	ΔB_{Hy}	– 0.1	–	0.1	mT		

¹⁾ Leakage currents at pin 4 should be avoided. The bias shift of B_m caused by a leakage current I_L can be

$$\text{calculated by: } \Delta B_m = \frac{I_L \times R_C(T)}{S_C(T)}$$

²⁾ For higher ΔB the values may exceed the limits like following $|\Delta B_m| < |0.05 \times \Delta B|$

³⁾ For definition see page 16.

⁴⁾ Depends on filter capacitor C_F . The cut-off frequency is given by $f = \frac{1}{2\pi \times R_C \times C_F}$. The switching points are guaranteed over the whole frequency range, but amplitude modification and phase shift due to the 1st order highpass filter have to be taken into account.

⁵⁾ See page 17.

Note: The listed characteristics are ensured over the operating range of the integrated circuit. Typical characteristics specify mean values expected over the production spread. If not otherwise specified, typical characteristics apply at $T_j = 25^\circ\text{C}$ and the given supply voltage.

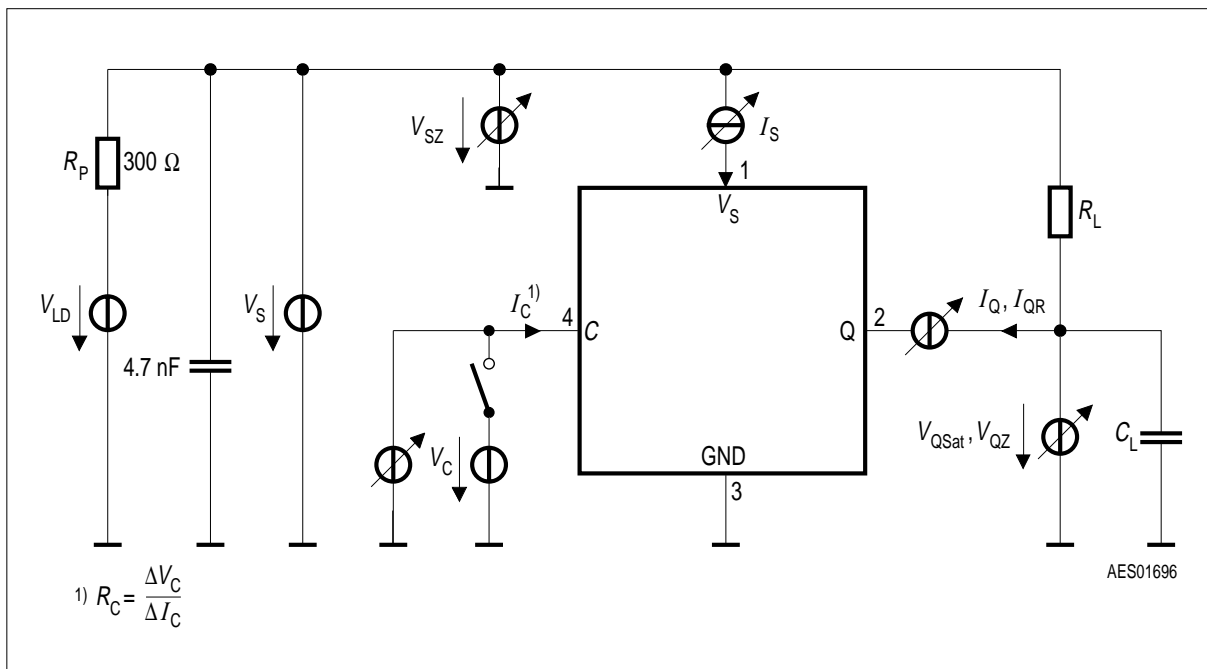

Figure 3 Test Circuit 1

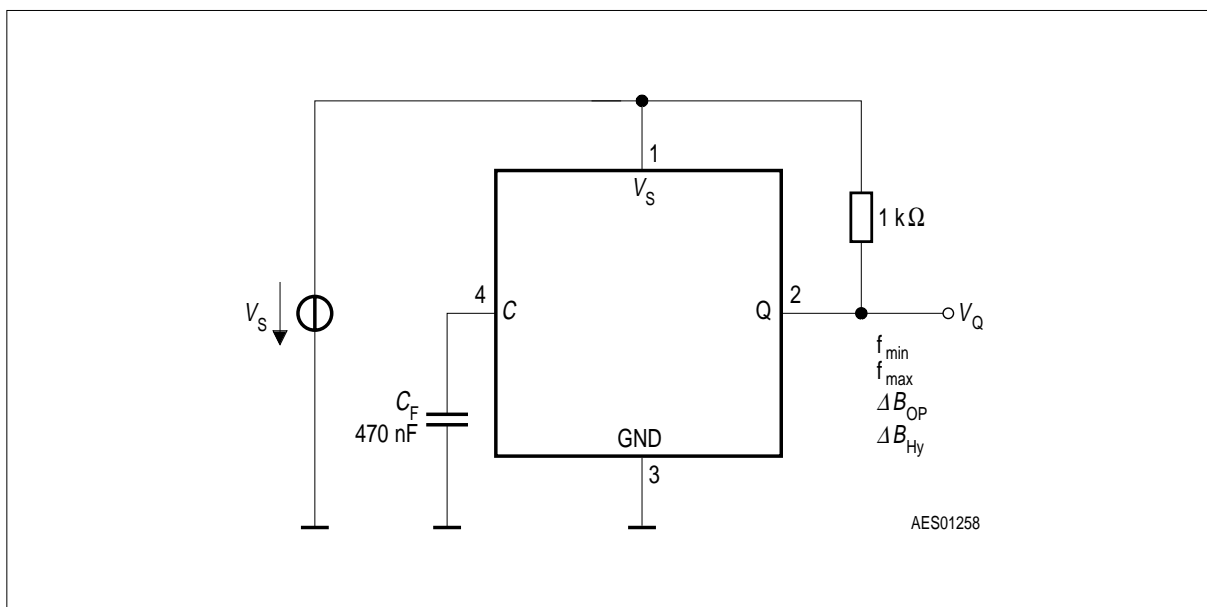

Figure 4 Test Circuit 2

Application Configurations

Two possible applications are shown in **Figure 7 and 8** (Toothed and Magnet Wheel). The difference between two-wire and three-wire application is shown in **Figure 9**.

Gear Tooth Sensing

In the case of ferromagnetic toothed wheel application the IC has to be biased by the south or north pole of a permanent magnet (e.g. SmCO₅ (Vacuumschmelze VX145) with the dimensions 8 mm × 5 mm × 3 mm) which should cover both Hall probes.

The maximum air gap depends on

- the magnetic field strength (magnet used; pre-induction) and
- the toothed wheel that is used (dimensions, material, etc.; resulting differential field)

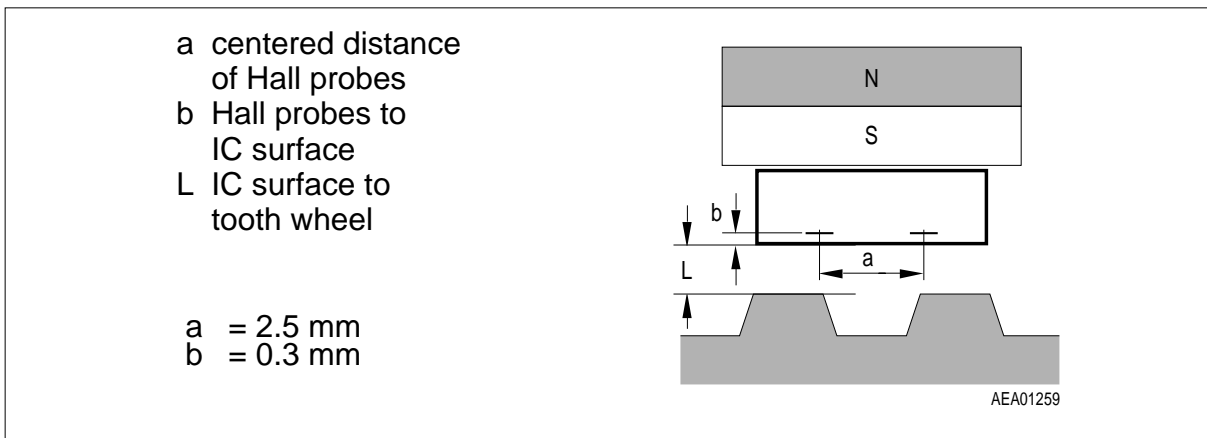

Figure 5 Sensor Spacing

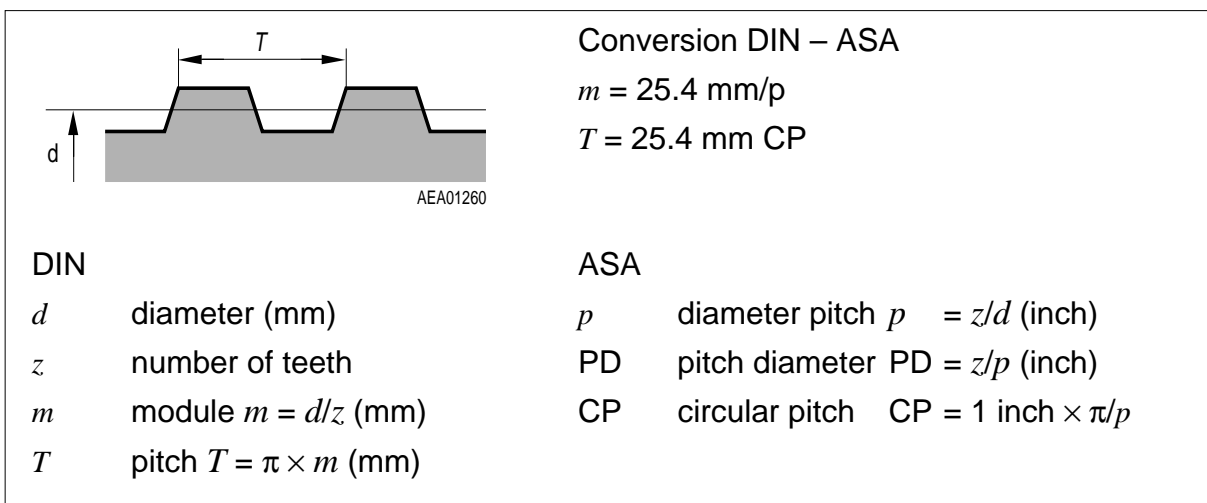

Figure 6 Toothed Wheel Dimensions

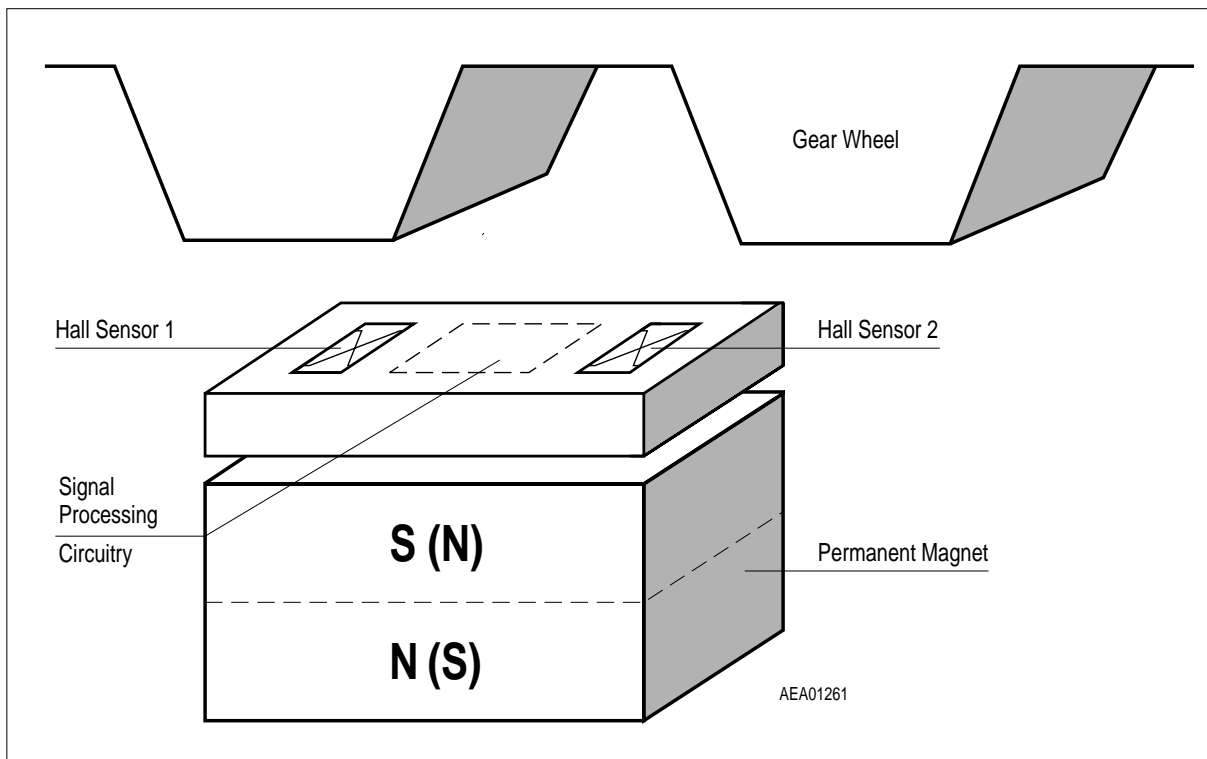

Figure 7 TLE 4921-3U, with Ferromagnetic Toothed Wheel

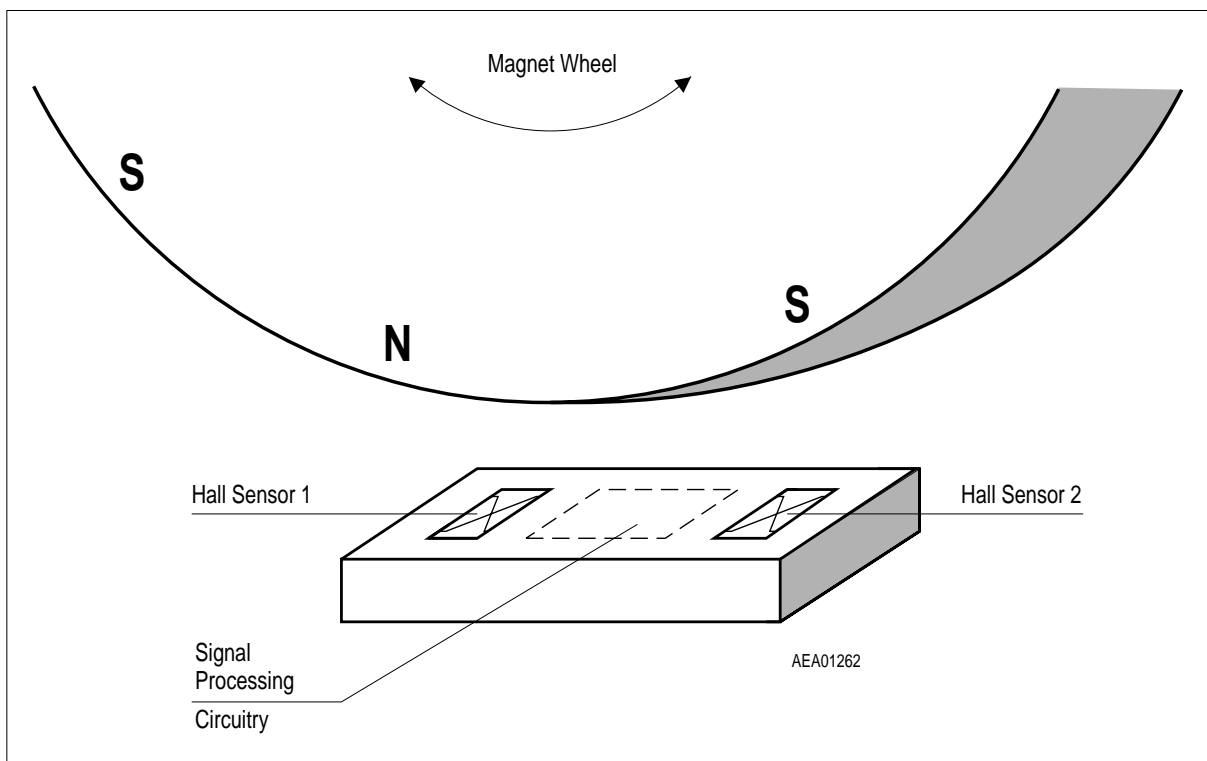

Figure 8 TLE 4921-3U, with Magnet Wheel

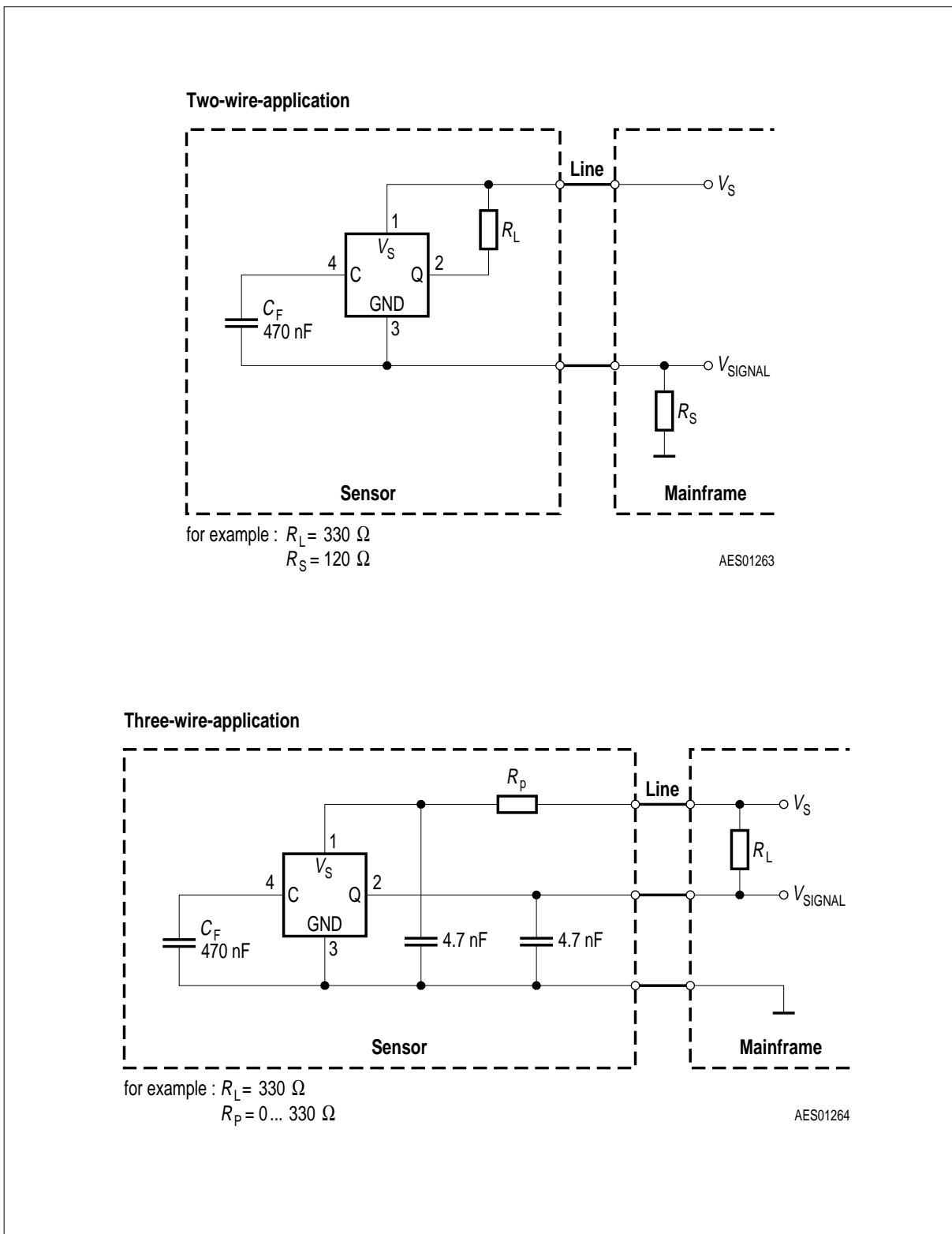

Figure 9 Application Circuits

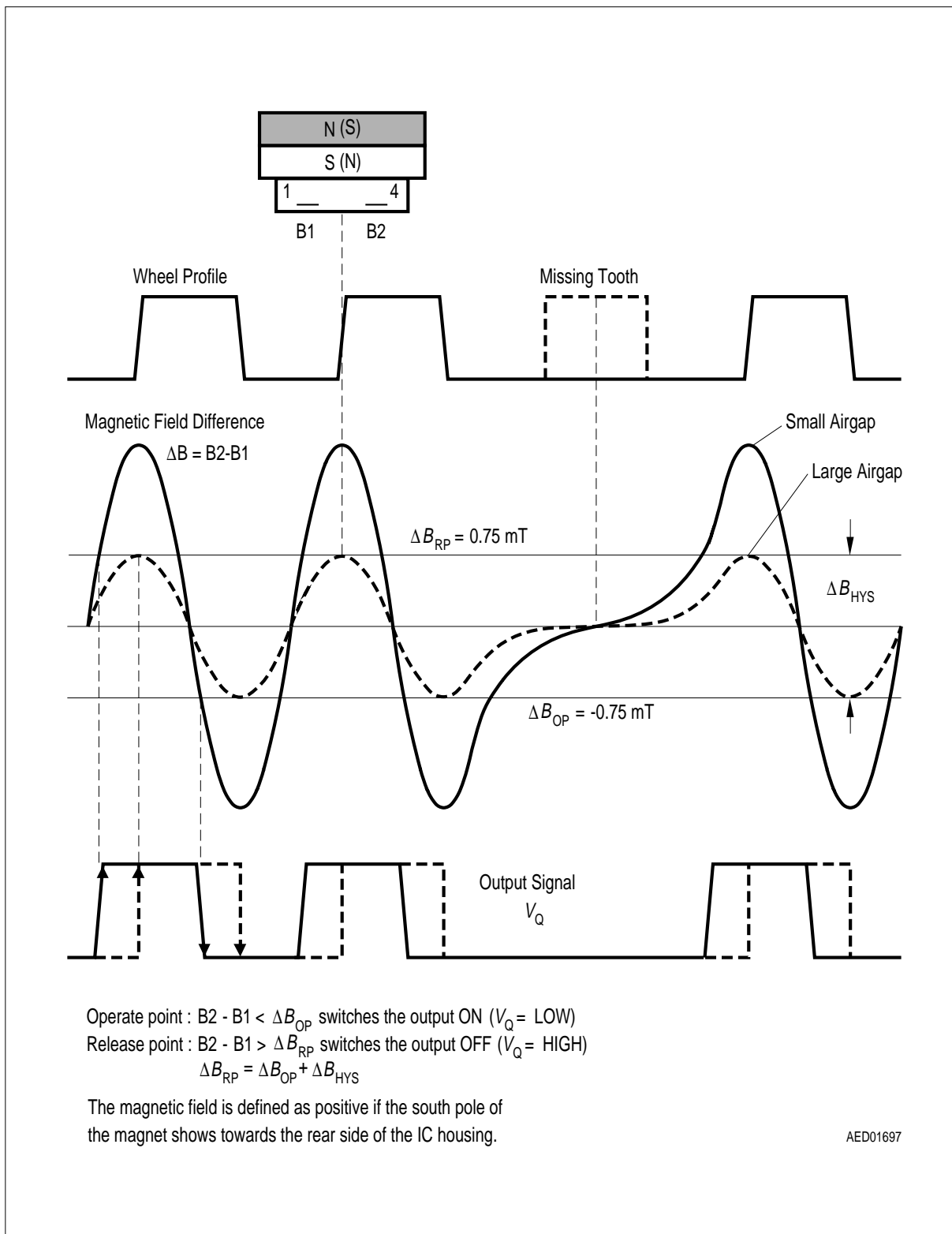
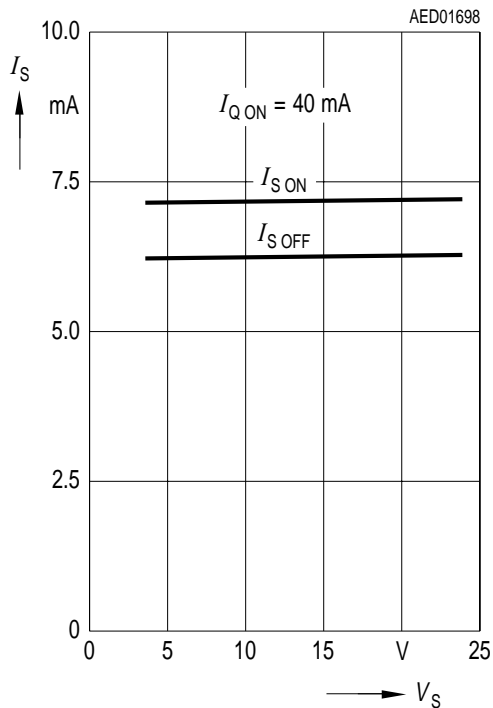
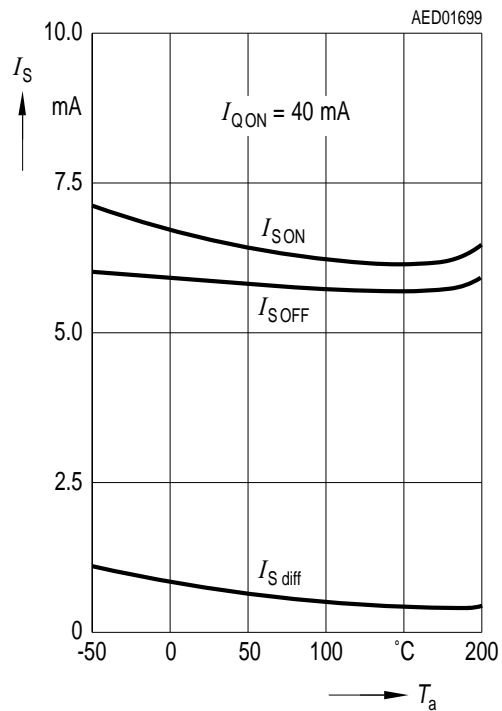

Figure 10 System Operation

Quiescent Current versus Supply Voltage



Quiescent Current versus Temperature



Quiescent Current Difference versus Temperature

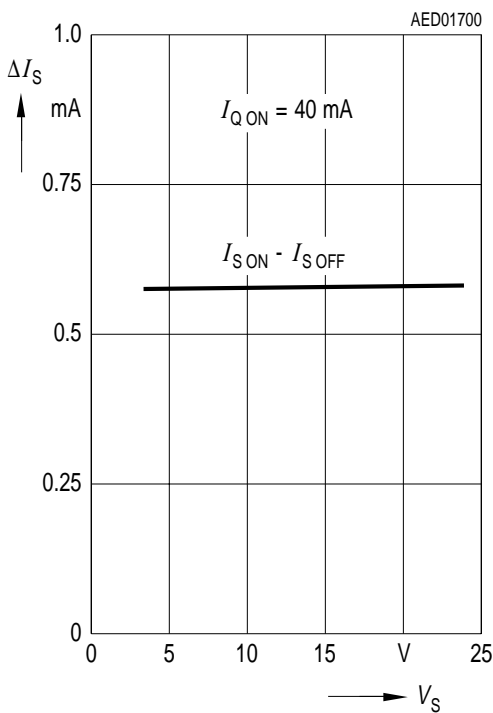

Quiescent Current versus Output Current

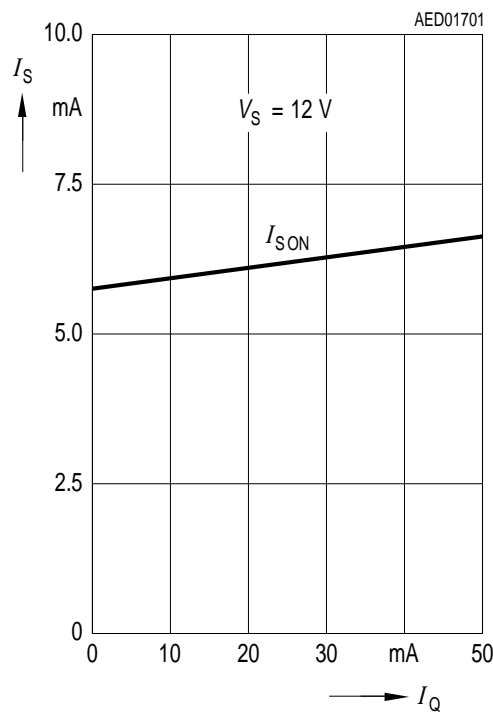

Saturation Voltage versus Temperature

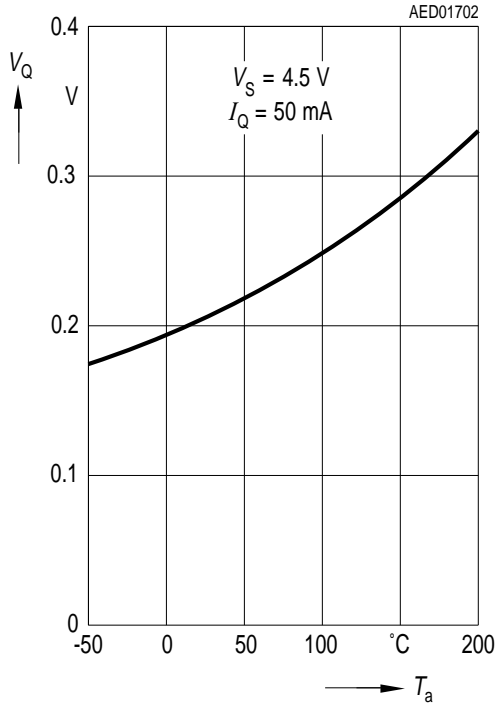

Saturation Voltage versus Output Current

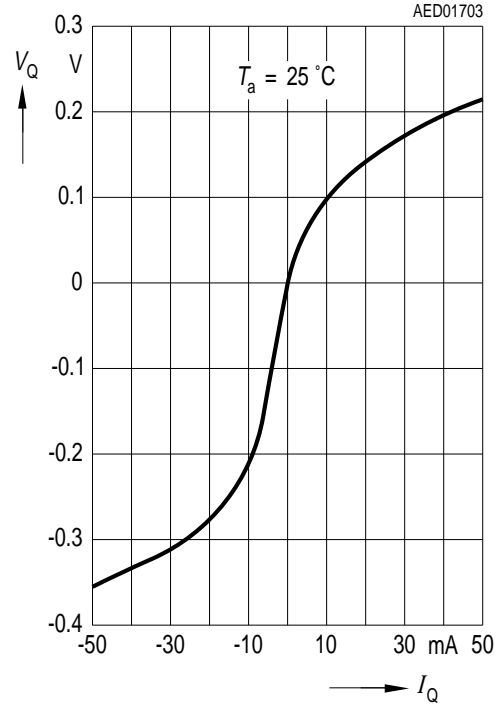

Saturation Voltage versus Supply Voltage

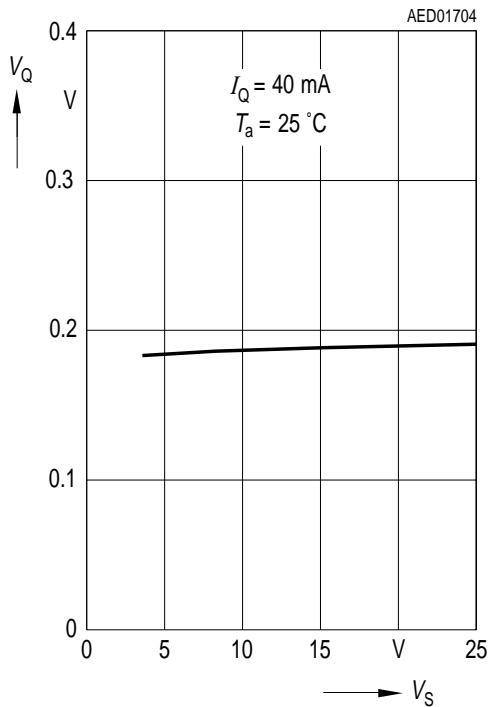

Switching Points versus Preinduction

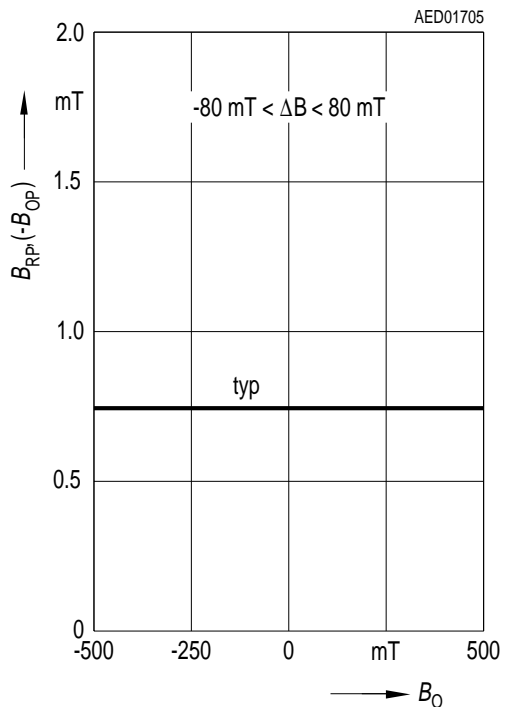

Switching Induction versus Temperature

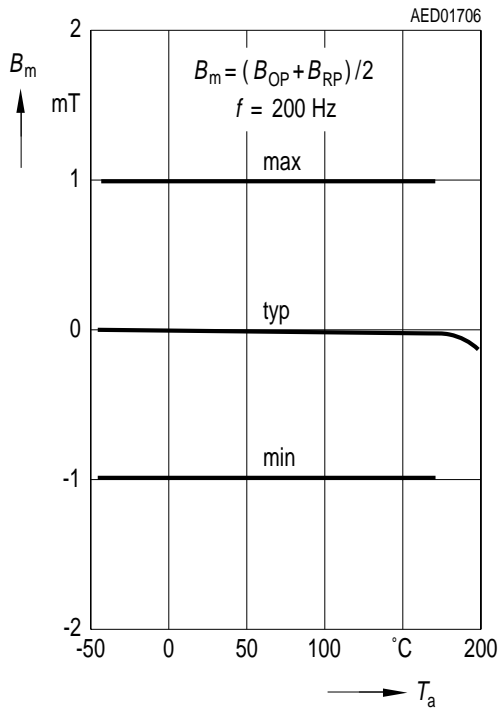

Hysteresis versus Temperature

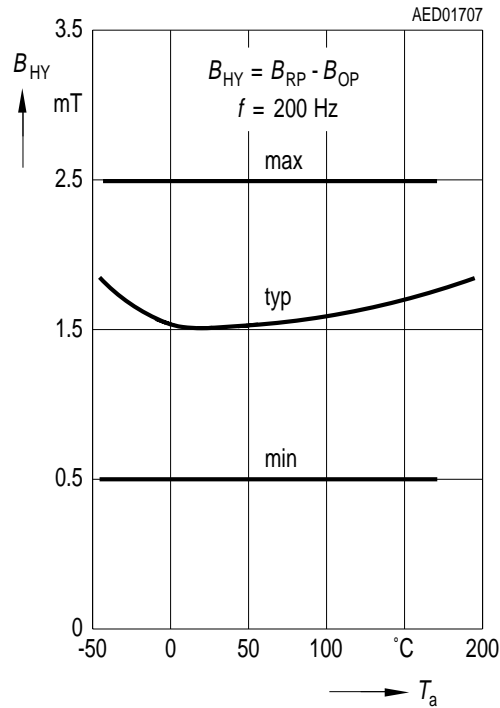

Minimum Switching Field versus Frequency

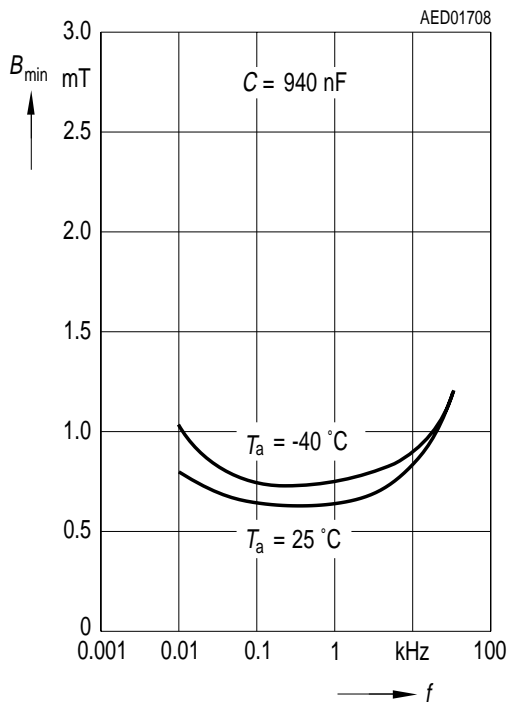

Minimum Switching Field versus Frequency

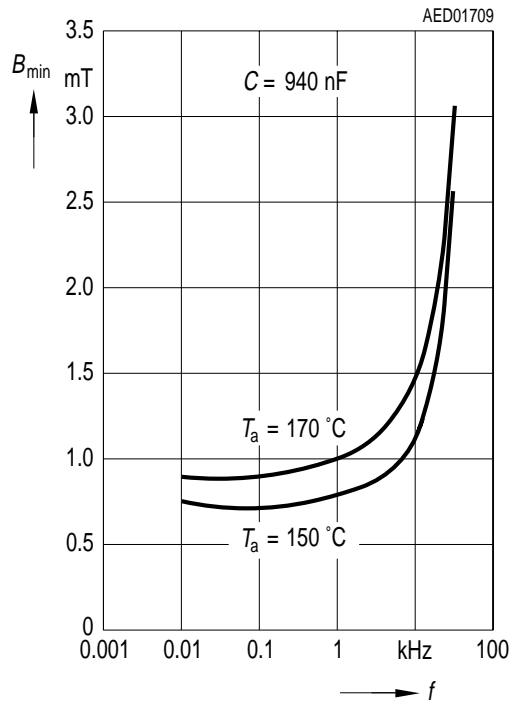

Delay Time¹⁾ between Switching Threshold ΔB and Falling Edge of V_Q at $T_j = 25\text{ }^\circ\text{C}$

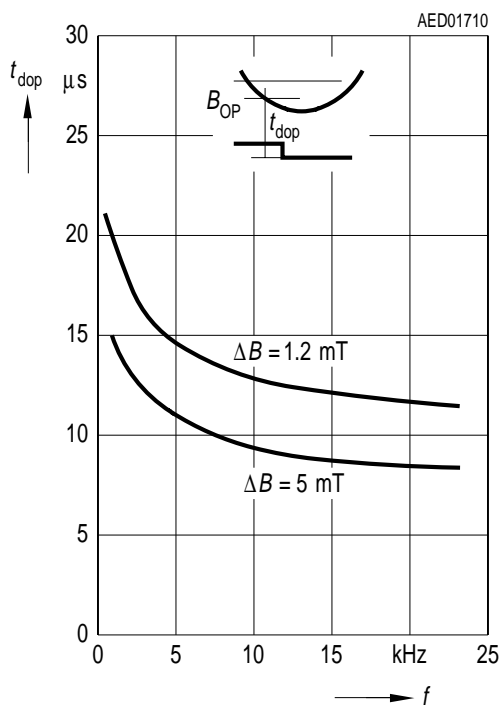

Delay Time¹⁾ between Switching Threshold ΔB and Rising Edge of V_Q at $T_j = 25\text{ }^\circ\text{C}$

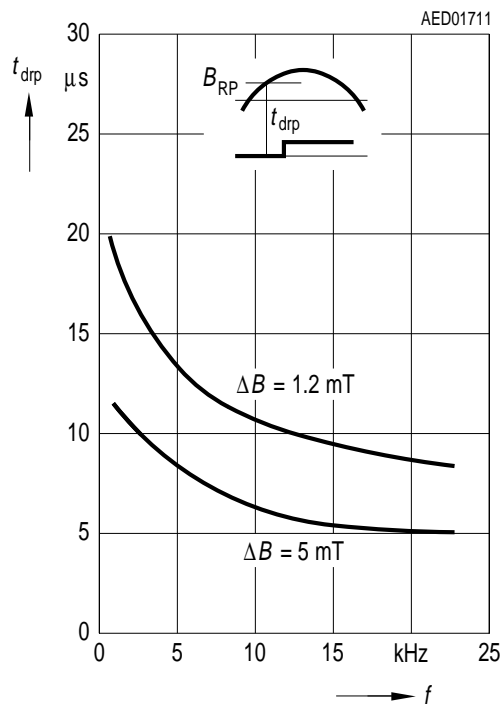

Delay Time¹⁾ versus Differential Field

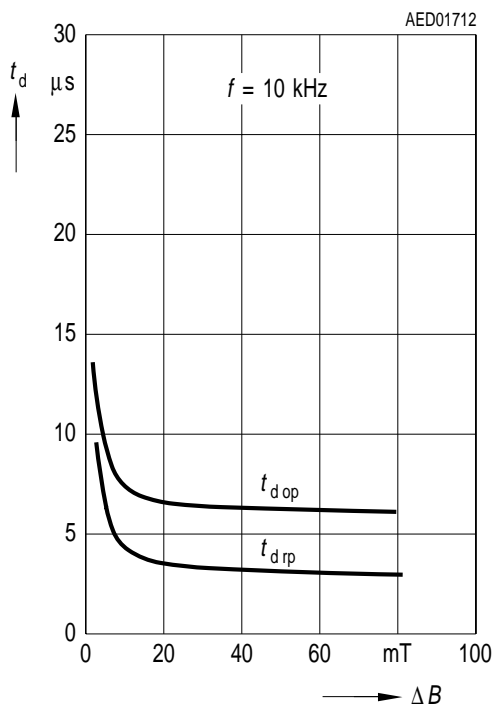

Delay Time¹⁾ versus Temperature

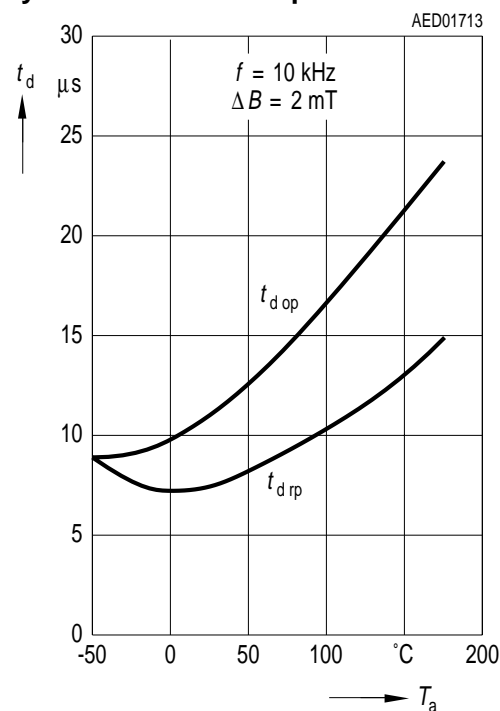

¹⁾ Switching points related to initial measurement
@ $\Delta B = 2\text{ mT}$, $f = 200\text{ Hz}$

Rise and Fall Time versus Temperature

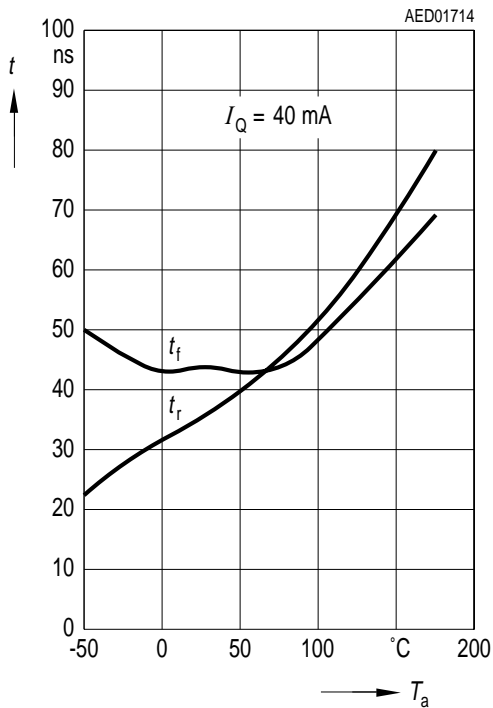

Rise and Fall Time versus Output Current

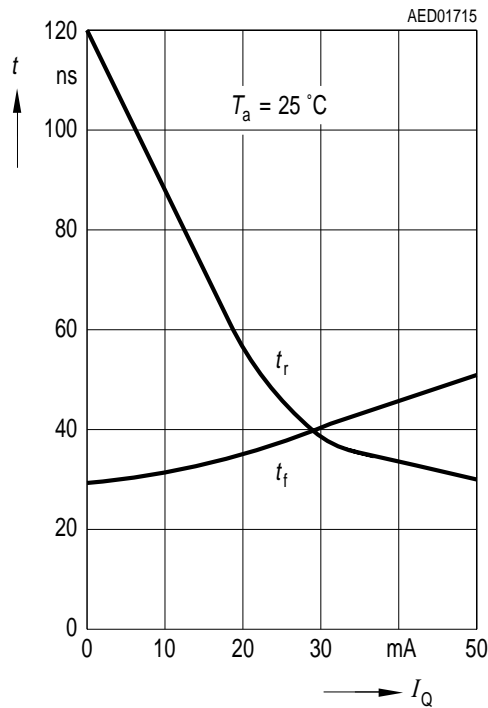

Capacitor Voltage versus Temperature



Switching Thresholds versus Mechanical Stress

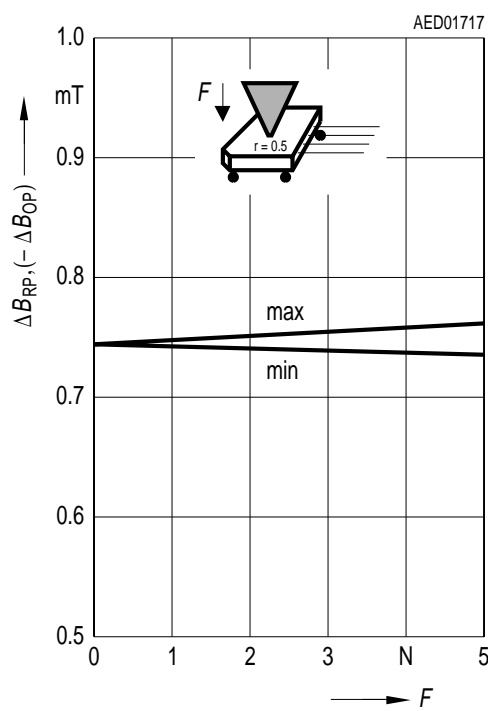

Filter Sensitivity versus Temperature

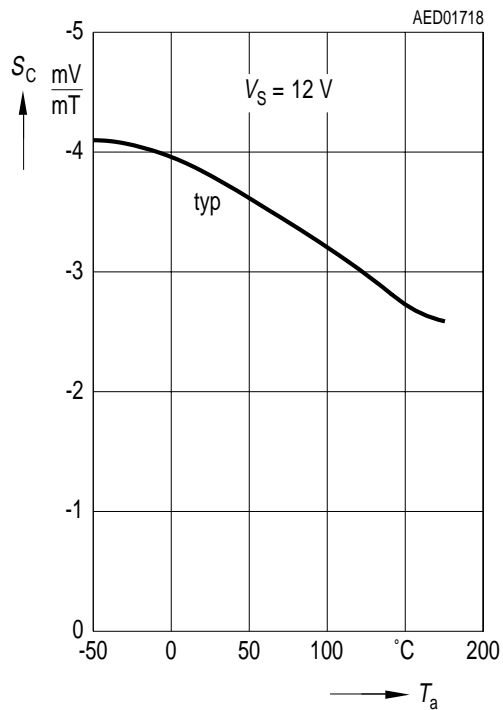

Filter Input Resistance versus Temperature

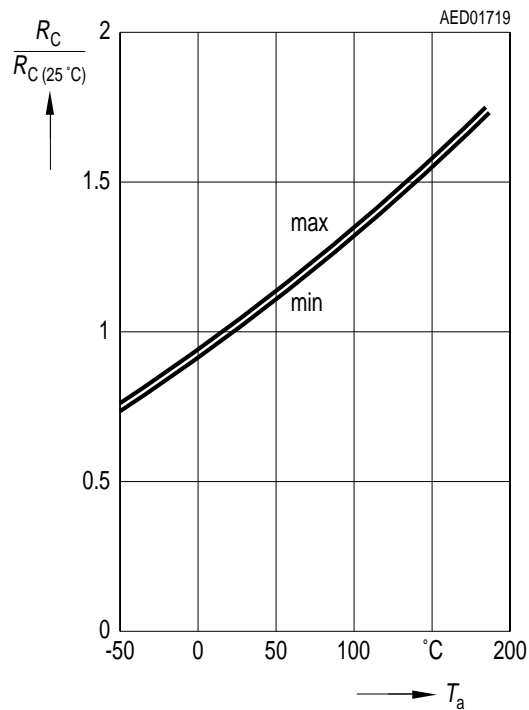

Delay Time for Power on (V_S Switching from 0 V to 4.5 V) t_{pon} versus Temp.

