

TB62801F

Linear CCD Clock Driver

TB62801F is a clock distribution driver for CCD linear image sensors.

The IC can functionally drive the CCD input capacitance. It also supports inverted outputs, eliminating the need for crosspoint control.

The IC contains a 1 to 4 clock distribution driver for the main clock and 4-bit buffers for control signals.

Features

- High drivability: Guaranteed driving 450 [pF] load capacitance @ $f_{clock} = 20$ [MHz]
- Operating temperature range: $T_a = -25^{\circ}\text{C}$ to 60°C

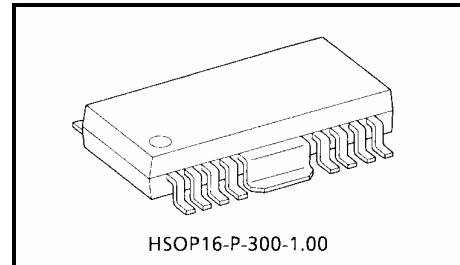

Weight: 0.5 g (typ.)

Pin Connection (top view)

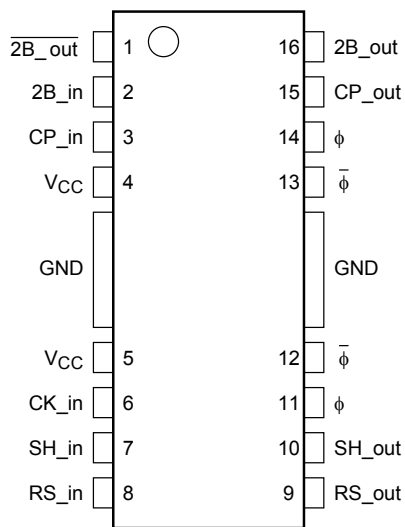

Logic Diagram

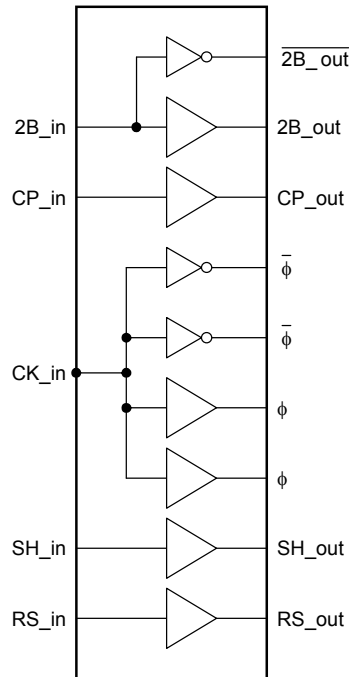

Pin Description

Pin No.	Pin Name	Functions	Remarks
1	$\overline{2B_out}$	Light-load drive output (inverted)	Driver output for CCD last-stage clock
2	2B_in	Light-load drive input	Driver input for CCD last-stage clock
3	CP_in	Light-load drive input	CCD clamp gate driver input
4	V _{CC}	Power supply	—
	GND	Ground	—
5	V _{CC}	Power supply	—
6	CK_in	Heavy-load drive input	Driver input for CCD transfer clock
7	SH_in	Light-load drive input	CCD shift gate driver input
8	RS_in	Light-load drive input	CCD reset gate driver input
9	RS_out	Light-load drive output (not inverted)	CCD reset gate driver output
10	SH_out	Light-load drive output (not inverted)	CCD shift gate driver output
11	ϕ	Heavy-load drive output (not inverted)	Driver output for CCD transfer clock
12	$\bar{\phi}$	Heavy-load drive output (inverted)	Driver output for CCD transfer clock
	GND	Ground	—
13	$\bar{\phi}$	Heavy-load drive output (inverted)	Driver output for CCD transfer clock
14	ϕ	Heavy-load drive output (not inverted)	Driver output for CCD transfer clock
15	CP_out	Light-load drive output (not inverted)	CCD clamp gate driver output
16	2B_out	Light-load drive output (not inverted)	Driver output for CCD last-stage clock

Truth Table

Input		Output	
2B_in	L	$\overline{2B_out}$	H
	H		L
	L	2B_out	L
	H		H
CP_in	L	CP_out	L
	H		H
CK_in	L	ϕ	L
	H		H
	L	$\overline{\phi}$	H
	H		L
SH_in	L	SH_out	L
	H		H
RS_in	L	RS_out	L
	H		H

Absolute Maximum Ratings (Ta = 25°C)

Characteristic	Symbol	Rating	Unit	
Power supply voltage	V _{CC}	-0.5 to 7.0	V	
Input voltage	V _{IN}	-1.2 to V _{CC} +0.5	V	
Output voltage	V _O	-0.5 to V _{CC}	V	
Input clamp diode current (V _i < 0)	I _{IK}	-50	mA	
Output clamp diode current (V _O < 0)	I _{OK}	-50	mA	
Output current excluding other than ϕ , $\overline{\phi}$ outputs	High level	I _{OH} (O/ \overline{O})	-16.0	mA
	Low level	I _{OL} (O/ \overline{O})	16.0	mA
ϕ output current	High level	I _{OH} ($\phi/\overline{\phi}$)	-100	mA
	Low level	I _{OL} ($\phi/\overline{\phi}$)	150	mA
Operating temperature	T _{opr}	-25 to 60	°C	
Storage temperature	T _{stg}	-40 to 100	°C	
Junction temperature	T _j	150	°C	
Power dissipation	P _D	1.5	W	

Note: Output current is specified as follows: V_{OH} = 4.0 V, V_{OL} = 0.5 V.

Recommended Operating Conditions

Characteristic		Symbol	Min	Typ.	Max	Unit
Power supply voltage		V_{CC}	4.7	5.0	5.5	V
Input voltage		V_{IN}	0	—	V_{CC}	V
Output voltage		V_O	0	—	V_{CC}	V
Output current excluding ϕ , $\bar{\phi}$ outputs	High level	$I_{OH} (O/\bar{O})$	—	—	-8.0	mA
	Low level	$I_{OL} (O/\bar{O})$	—	—	8.0	mA
ϕ output current (Note)	High level	$I_{OH} (\phi/\bar{\phi})$	—	—	-20.0	mA
	Low level	$I_{OL} (\phi/\bar{\phi})$	—	—	20.0	mA
Operating temperature		T_{opr}	-25	25	60	°C
Input rise/fall time		t_{ri}/t_{fi}	—	2.5	5.0	ns

Note: Output current is specified as follows: $V_{CC} = 4.7$ V, $V_{OH} = 4.5$ V, $V_{OL} = 0.2$ V.
 Input rise/fall time is specified as 10 % to 90 % of waveform amplitude.

Electrical Characteristics

DC Characteristics (unless otherwise specified, $V_{CC} = 4.7$ to 5.5 V, $T_a = -25$ to 60°C)

Characteristic		Symbol	Test Circuit	Test Condition	V_{CC}	Min	Typ.	Max	Unit
Input voltage	High	V_{IH}	1, 2	—	4.7	2.0	—	V_{CC}	V
	Low	V_{IL}		—	4.7	0	—	0.8	
Input clamp voltage		V_{IK}	3	$I_{IK} = -30$ mA	4.7	—	—	1.0	V
ϕ output voltage	$V_{OH} (\phi/\bar{\phi})$	4, 5	$I_{OH} = -10$ mA	4.7	4.5	—	V_{CC}	V	
			$I_{OH} = -50$ mA	4.7	4.0	—	V_{CC}		
			$I_{OH} = -300$ mA	4.7	2.5	—	V_{CC}		
	$V_{OL} (\phi/\bar{\phi})$	6, 7	$I_{OL} = 100$ μ A	4.7	0	—	0.2		
			$I_{OL} = 50$ mA	4.7	0	—	0.5		
			$I_{OL} = 300$ mA	4.7	0	—	2.5		
Output voltage excluding ϕ , $\bar{\phi}$ outputs	$V_{OH} (O/\bar{O})$	4, 5	$I_{OH} (O/\bar{O}) = -4$ mA	4.7	4.5	—	V_{CC}	V	
			$I_{OH} (O/\bar{O}) = -16$ mA	4.7	4.0	—	V_{CC}		
	$V_{OL} (O/\bar{O})$	6, 7	$I_{OL} (O/\bar{O}) = 4$ mA	4.7	0	—	0.2		
			$I_{OL} (O/\bar{O}) = 16$ mA	4.7	0	—	0.5		
Input voltage		I_{IN}	8	$V_{IN} = V_{CC}$ or GND	5.5	—	—	1.0	μ A
Static current consumption	Total	I_{CC}	9	ϕ outputs: High or Low $\bar{\phi}$ outputs: Low or High Other outputs are High	5.5	—	—	15.0	mA
	Each bit	ΔI_{CC}	10	One input: $V_{IN} = 0.5$ V Other inputs: V_{CC} or GND	—	—	—	1.5	
Output off mode supply voltage		V_{POR}	—	See description on next page.	—	—	3.0	—	V

Output Low-Level Fixed Mode at Power On

To avoid malfunction at power on, this IC incorporates the following functions:

- All outputs are fixed to low level until V_{CC} reaches more than 3 V.
- When V_{CC} reaches 3 V (typ.), the internal logic depends on input signals.
- V_{CC} must be more than 4.7 V for normal operation.

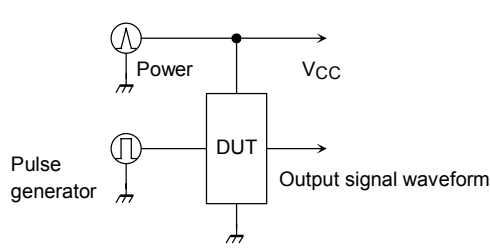

Additional circuit (P.O.R) test circuit

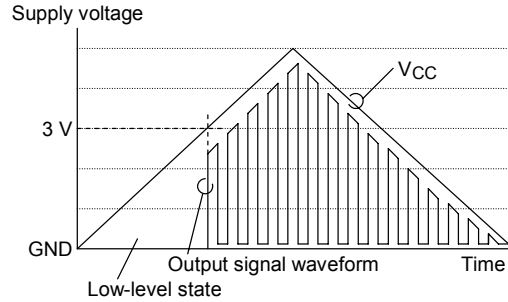

AC Characteristics (input transition rise or fall time: t_r/t_f = 2.5 ns)

Characteristic	Symbol	Test Condition	Normal Temperature/ V _{CC} = 5.0 V			All Temperatures/ V _{CC} = 4.7 to 5.5 V		Unit	Reference Measurement Diagram
			Min	Typ.	Max	Min	Max		
Propagation delay time	t _{pLH} (φ/φ̄)	C _L = 450 pF	7.0	10.0	14.0	7.0	16.0	ns	Measurement diagram 1
		C _L = 350 pF	6.0	9.0	13.0	6.0	15.0		
	t _{pHL} (φ̄/φ)	C _L = 450 pF	7.0	10.0	14.0	7.0	16.0		
		C _L = 350 pF	6.0	9.0	13.0	6.0	15.0		
Output skew excluding φ, φ̄ outputs	t _{pLH} (O/Ō)	C _L = 30 pF	3.0	5.0	7.0	2.5	8.0	ns	Measurement diagram 2
		C _L = 15 pF	2.0	4.0	6.0	1.5	7.0		
		C _L = 30 pF	3.0	5.0	7.0	2.5	8.0		
		C _L = 15 pF	2.0	4.0	6.0	1.5	7.0		
Output skew excluding φ, φ̄ outputs	t _o (skw)	C _L = 30 pF	0	—	2.0	—	2.0	ns	Measurement diagram 3
Output crosspoints (φ1/φ2)	V _T (crs)	C _L = 300 to 450 pF	—	—	—	1.5	—	V	Measurement diagram 4

Waveform Measuring Point

Propagation Delay Time Setting

Input signal

- 2B_in
- CK_in
- SH_in
- RS_in
- CP_in

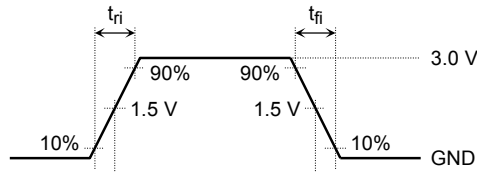

Measurement Diagram 1

Output signal

- ϕ

Output signal

- ϕ

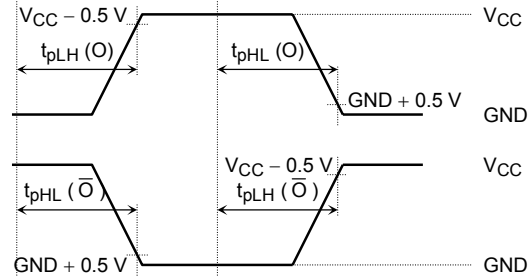

Measurement Diagram 2

Output signal

- 2B_out
- CP_out
- SH_out
- RS_out

Output signal

- 2B_out

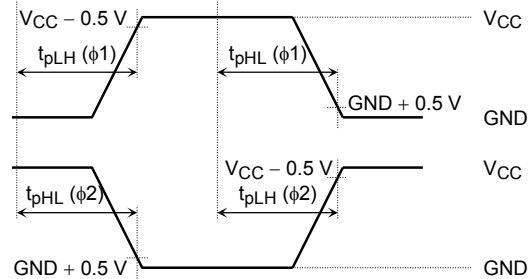

Measurement Diagram 3

Output signal

- 2B_out
- 2B_out
- CP_out
- SH_out
- RS_out

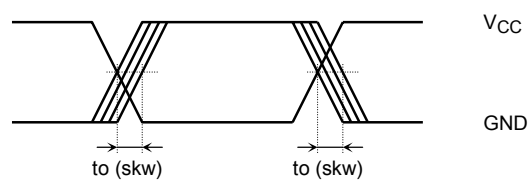

Output Waveform Crosspoint/Level Setting

Measurement Diagram 4

- ϕ

- $\bar{\phi}$

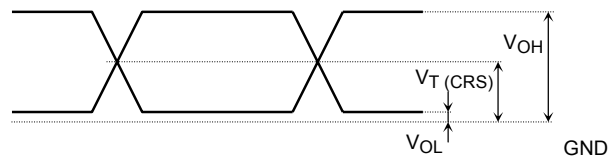

Reference Data (typ. value)

$t_{pLH}(\phi)$, $t_{pHL}(\phi) - C_L$
(characteristics of 1-output,
other outputs: no load)

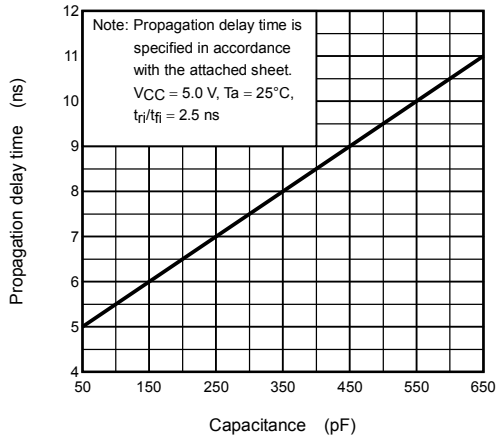

Load capacitance versus maximum
operating frequency (all bits in operation)
 $V_{CC} = 5.0\text{ V}$, $T_a = 25^\circ\text{C}$, $t_{r1}/t_{f1} = 2.5\text{ ns}$

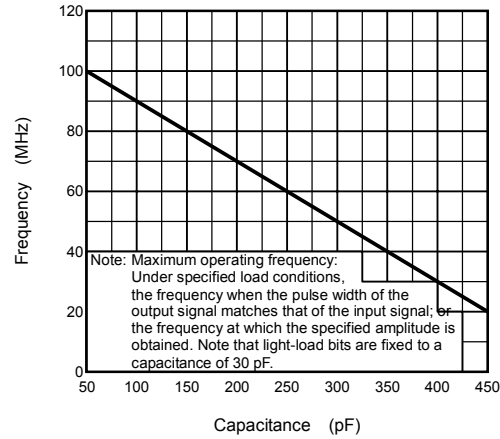

Frequency versus power dissipation,
temperature
(@all outputs: maximum load capacitance)

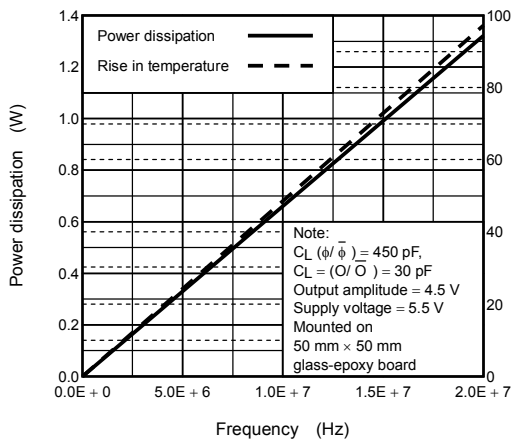

$P_D - T_a$

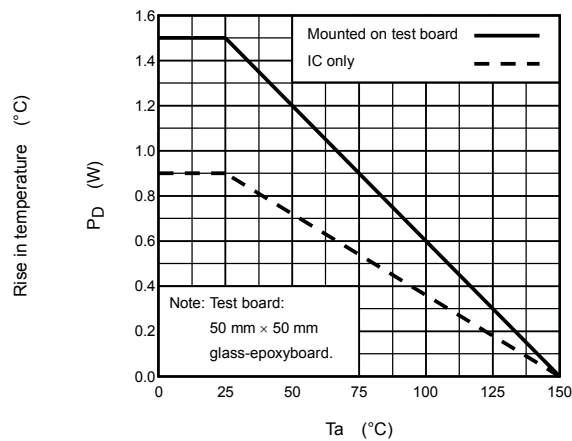

$\phi/\bar{\phi}$ output
 $I_{OL} - V_{OL}$

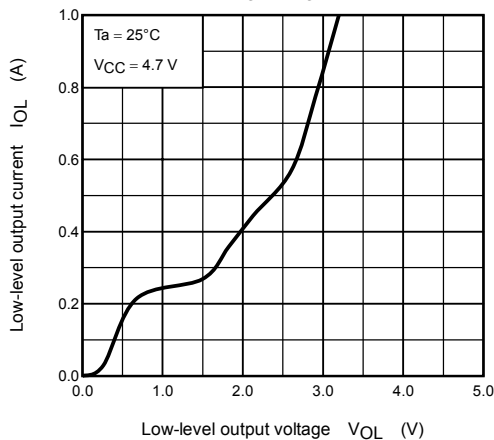

$\phi/\bar{\phi}$ output
 $I_{OH} - V_{OH}$

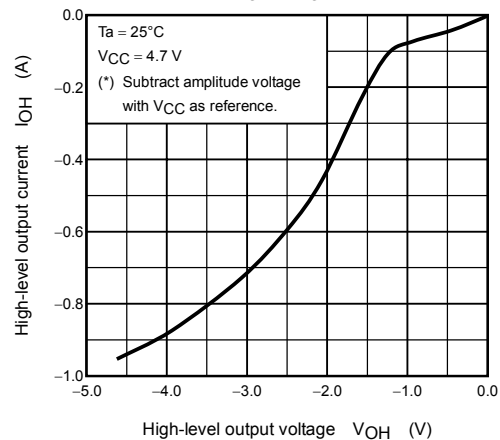

Test Circuit

DC Parameters

Pins marked with an asterisk (*) are test pins. However, ground any input pins that are not being used as test pins so that their logic is determined. Unless otherwise specified, bits of the same type are measured in the same way.

- V_{IH}/V_{IL}

(1) Light-load drive bit

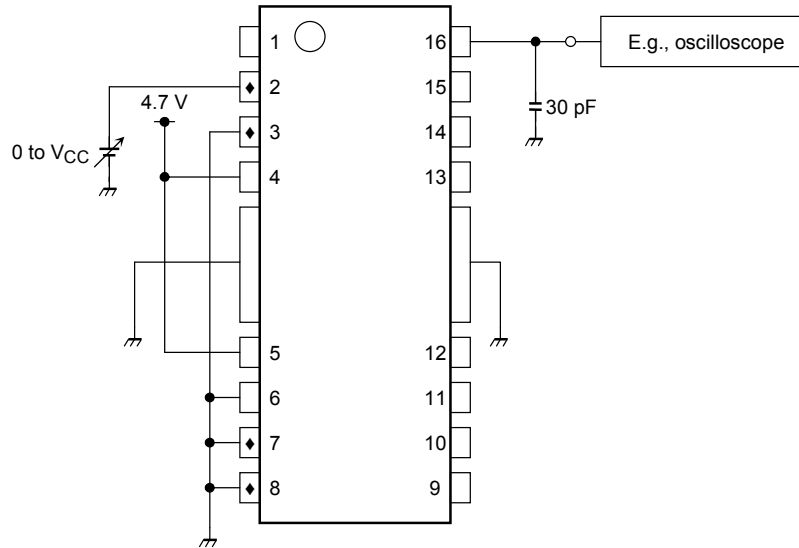

(2) Heavy-load drive bit

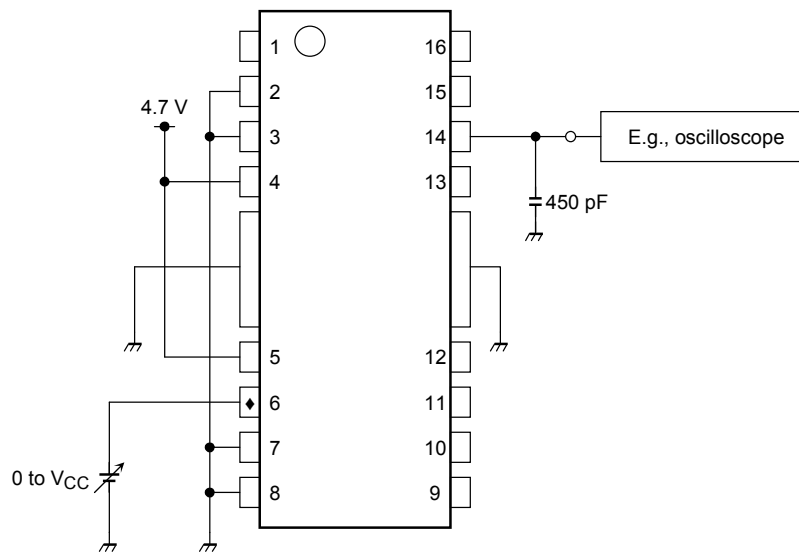

- V_{IK}

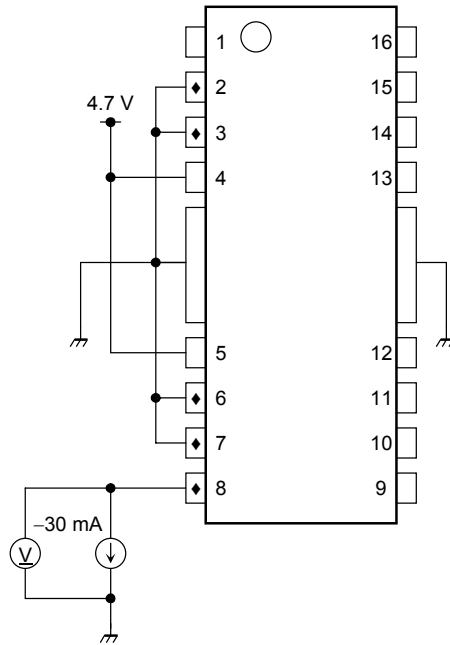

Note 1: When measuring input pins, connect the input pins that are not being measured to GND.

- $V_{OH} (O/\phi)$

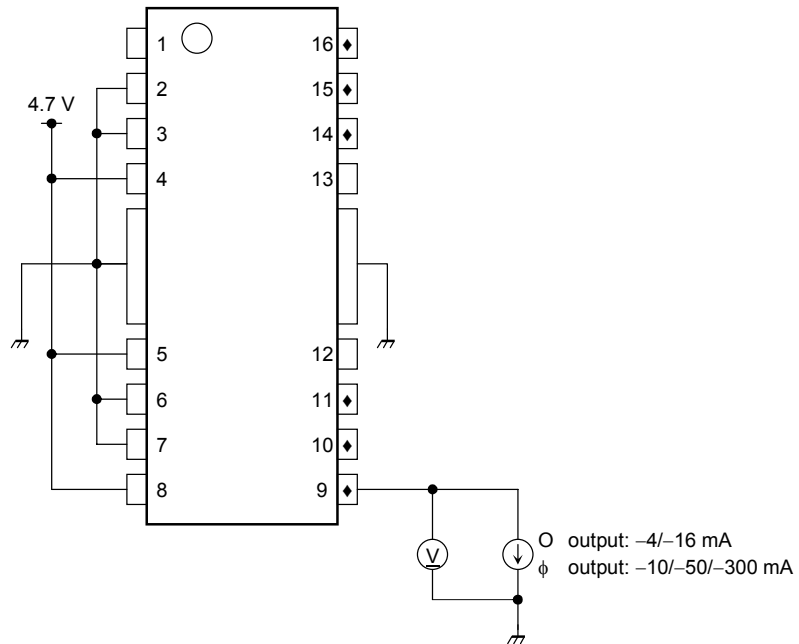

- $V_{OH} (\bar{O}/\bar{\phi})$

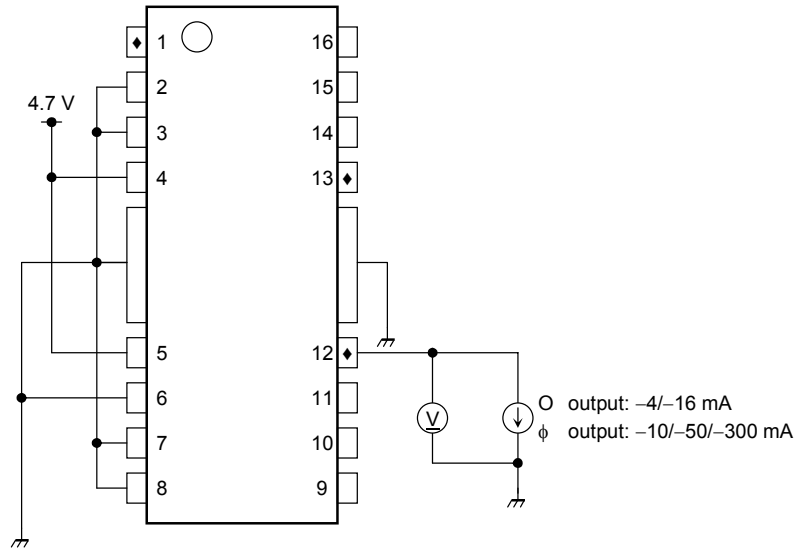

- $V_{OL} (O/\phi)$

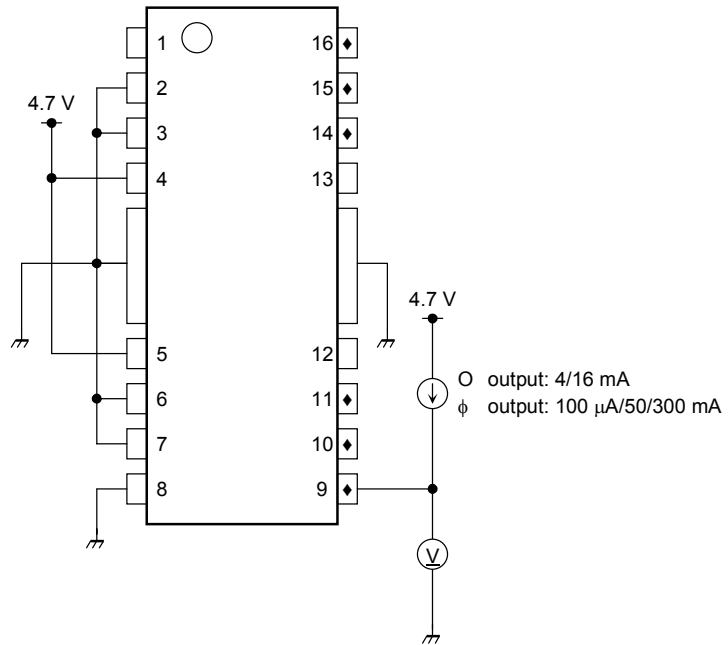

- $V_{OL} (\bar{O}/\bar{\phi})$

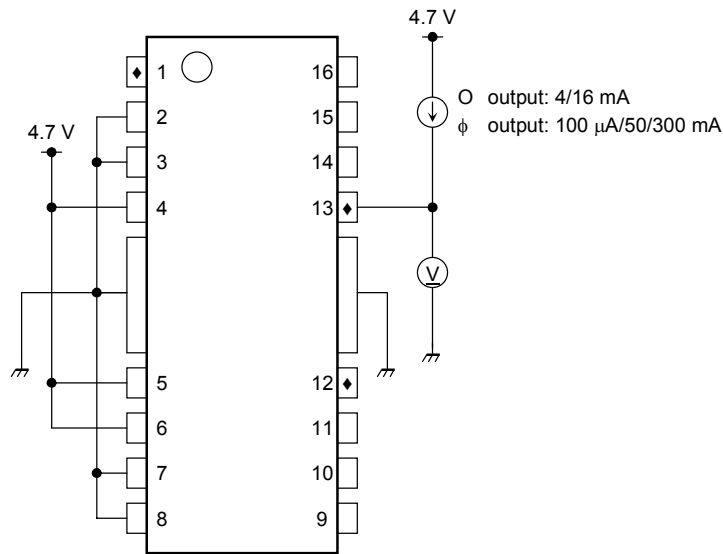

- I_{IN}

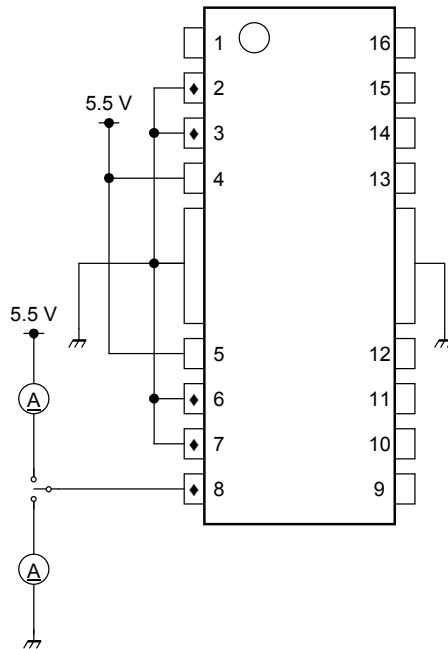

Note: When measuring input pins, connect the input pins that are not being measured to GND.

- I_{CC}

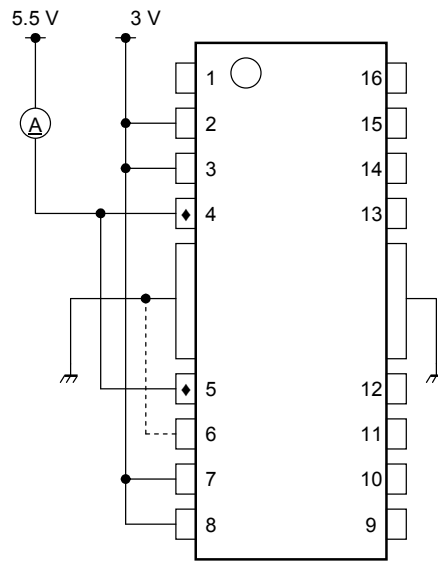

Note 1: The input logic of the heavy-load drive clock input pin (pin 6) is the same for High or Low.

- ΔI_{CC}

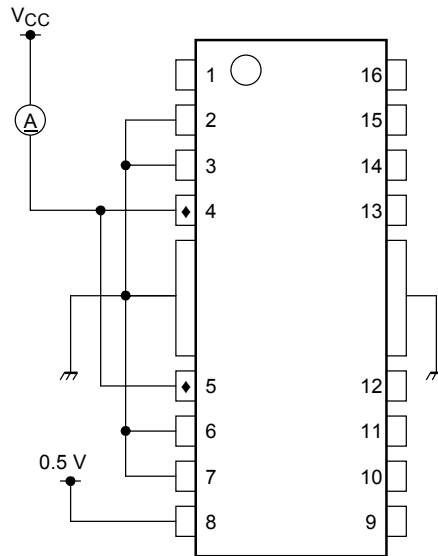

Note 2: When measuring input pins, connect the input pins that are not being measured to GND or power.

AC Parameters

Pins marked with an asterisk (*) are test pins. Ground the input pins that are not being used as test pins so that their logic is determined. Unless otherwise specified, bits of the same type are measured in the same way.

- **Propagation Delay Time**

(1) Light-load drive bit

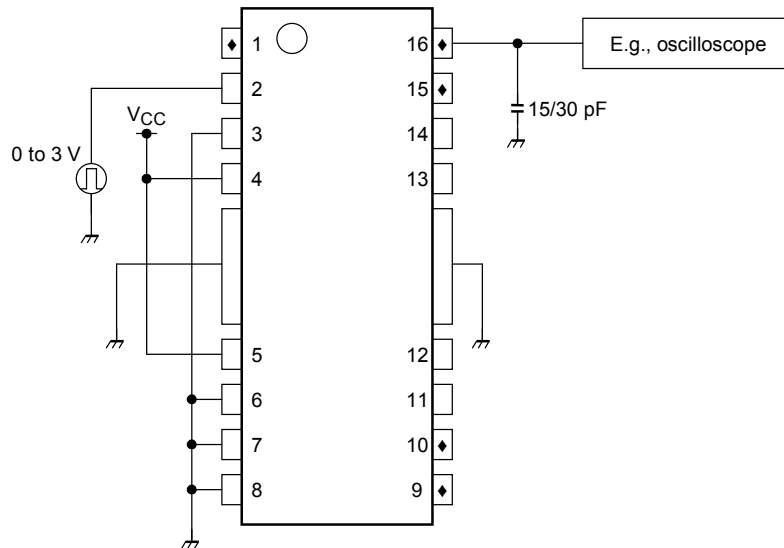

(2) Heavy-load drive bit

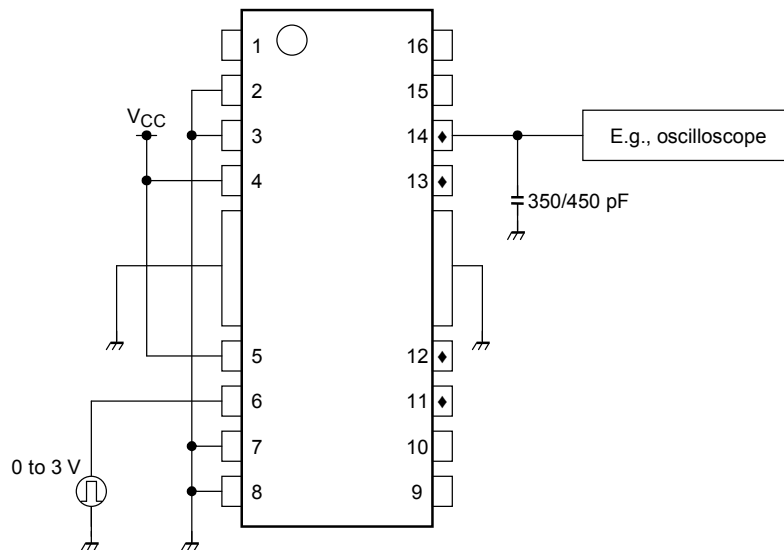

- **Light-Load Drive Output Skew**

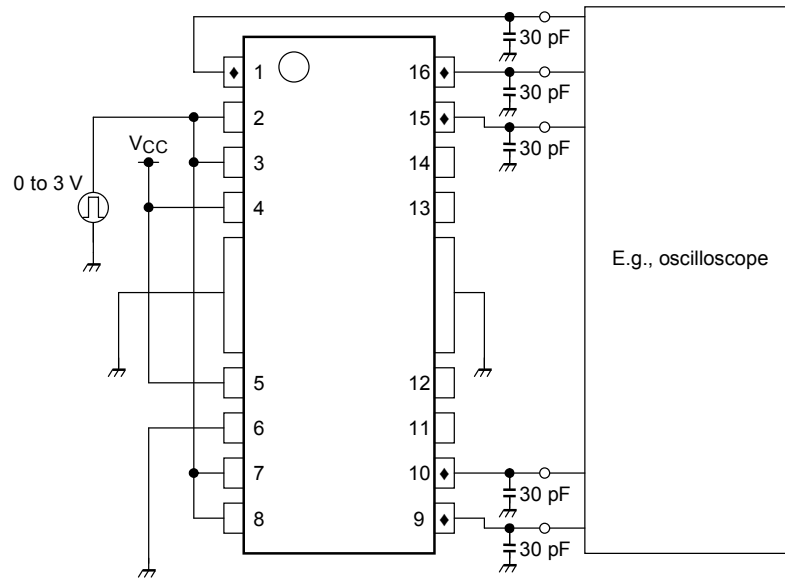

- **Heavy-Load Drive Output Crosspoints**

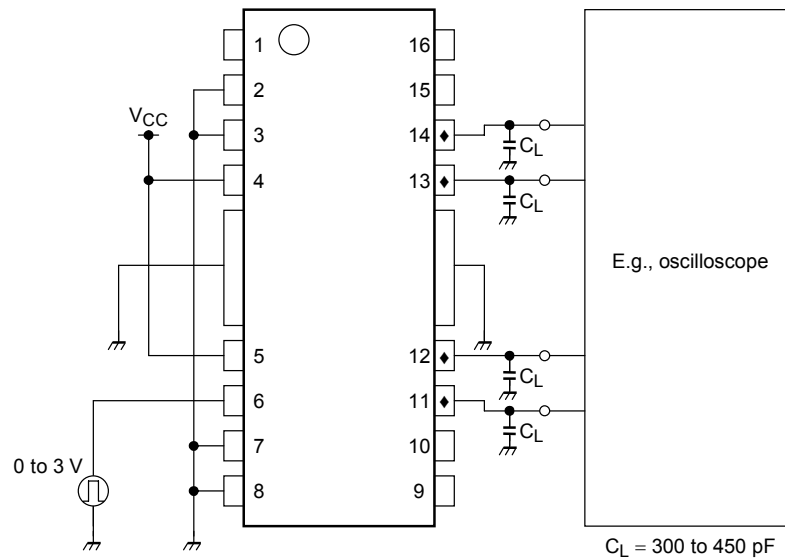

Example of an Application Circuit

(1) Connection to the TCD1503C

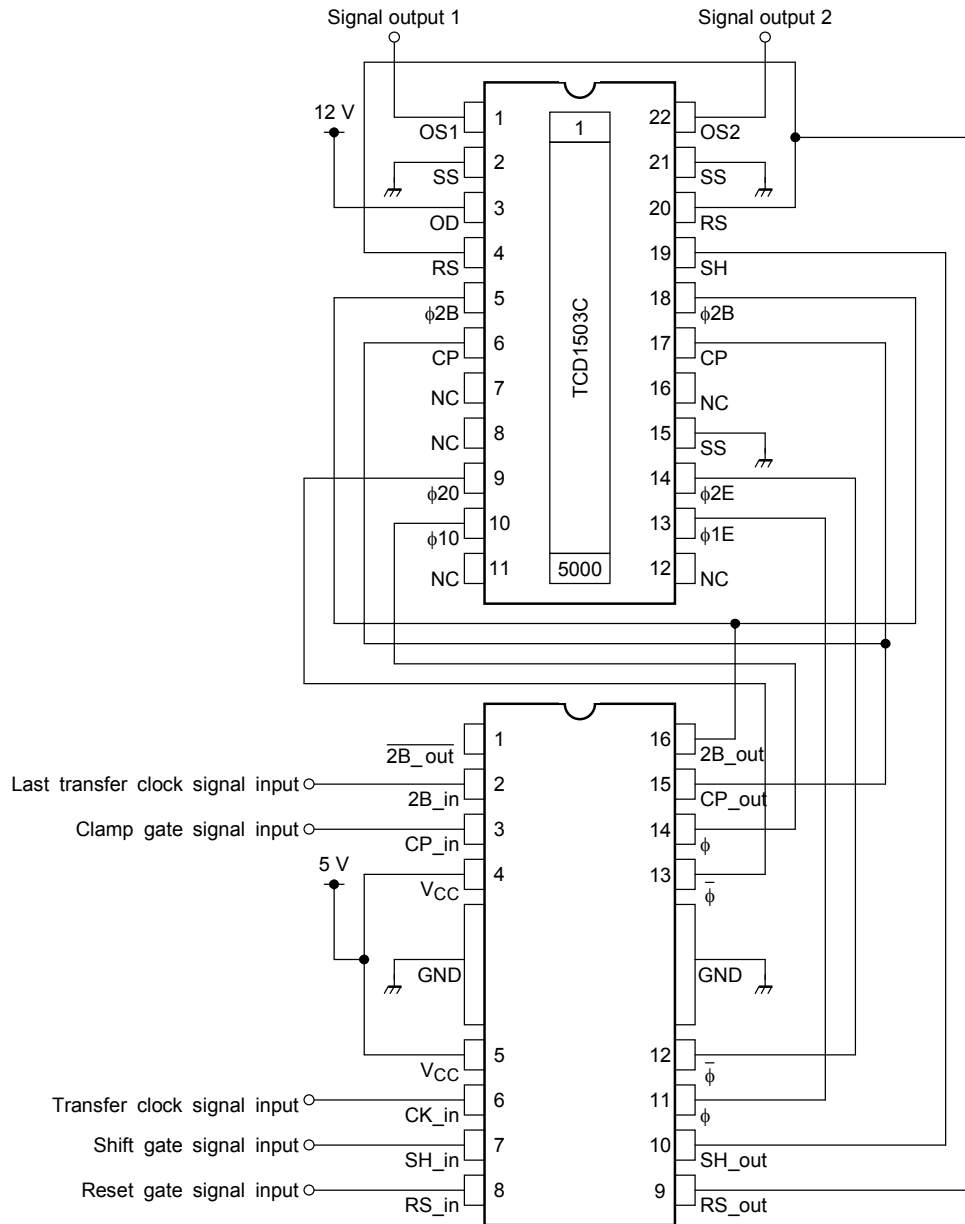

Note: Driving the CCD requires a lot of power. Toshiba recommends the use of a bypass capacitor connected to the 5 V power supply to stabilize voltage.

Precautions on Use

This product does not include built-in protection circuits for excess current or overvoltage. If the IC is subjected to excess current or overvoltage, it may be destroyed. Therefore systems incorporating the IC should be designed with the utmost care.

Particular care is necessary in the design of the output, VCC and GND lines since the IC may be destroyed by short circuits between outputs, air contamination faults, or faults due to improper grounding.

(2) Connection to the TCD1703C

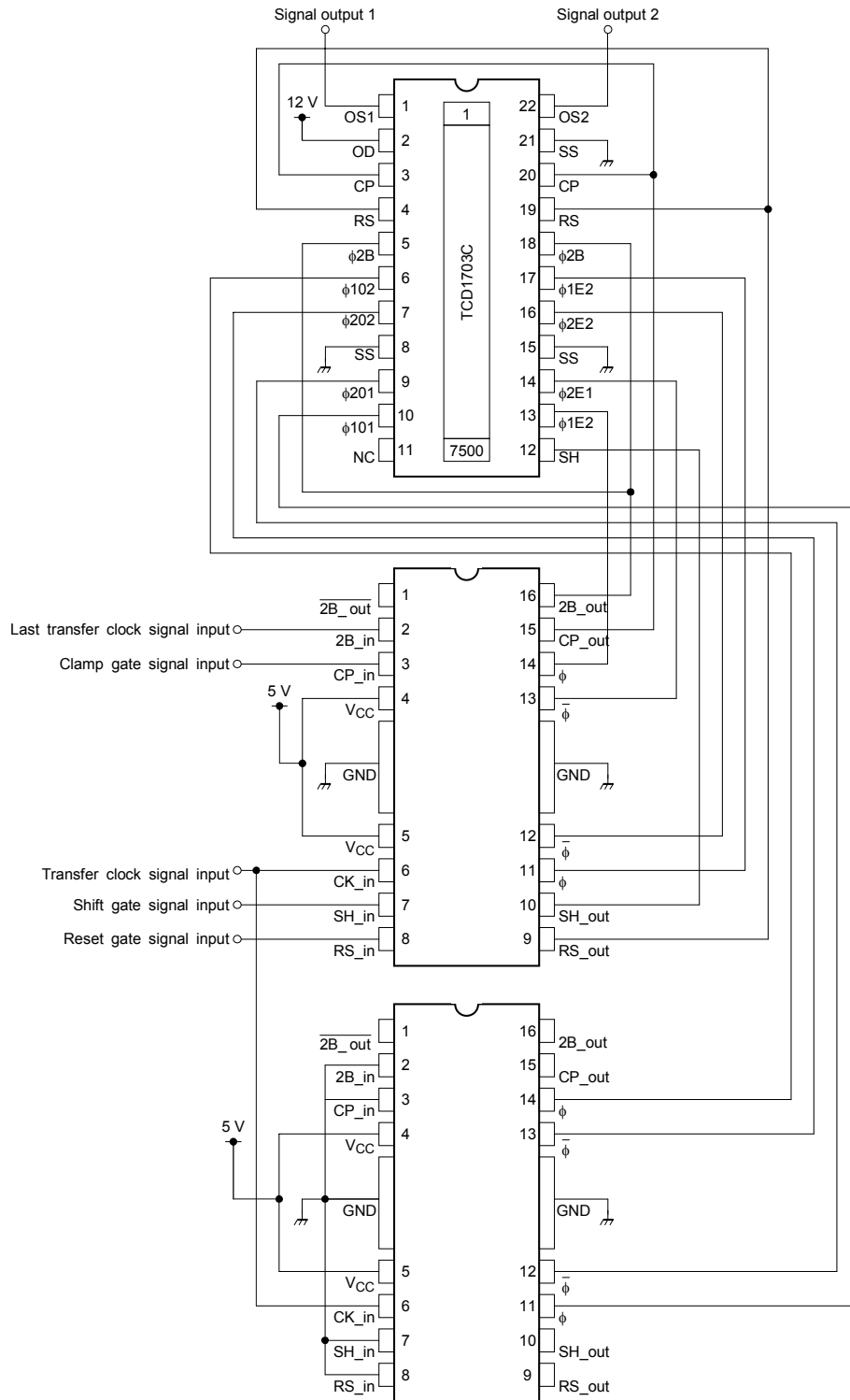

Note: Driving the CCD requires a lot of power. Toshiba recommends the use of a bypass capacitor connected to the 5 V power supply to stabilize voltage.
 Two TB62801F devices are used in this application: one is used to drive all the control bits and the four transfer clock bits, the other to drive the remaining four transfer clock bits.

Package Dimensions

HSOP16-P-300-1.00

Unit: mm

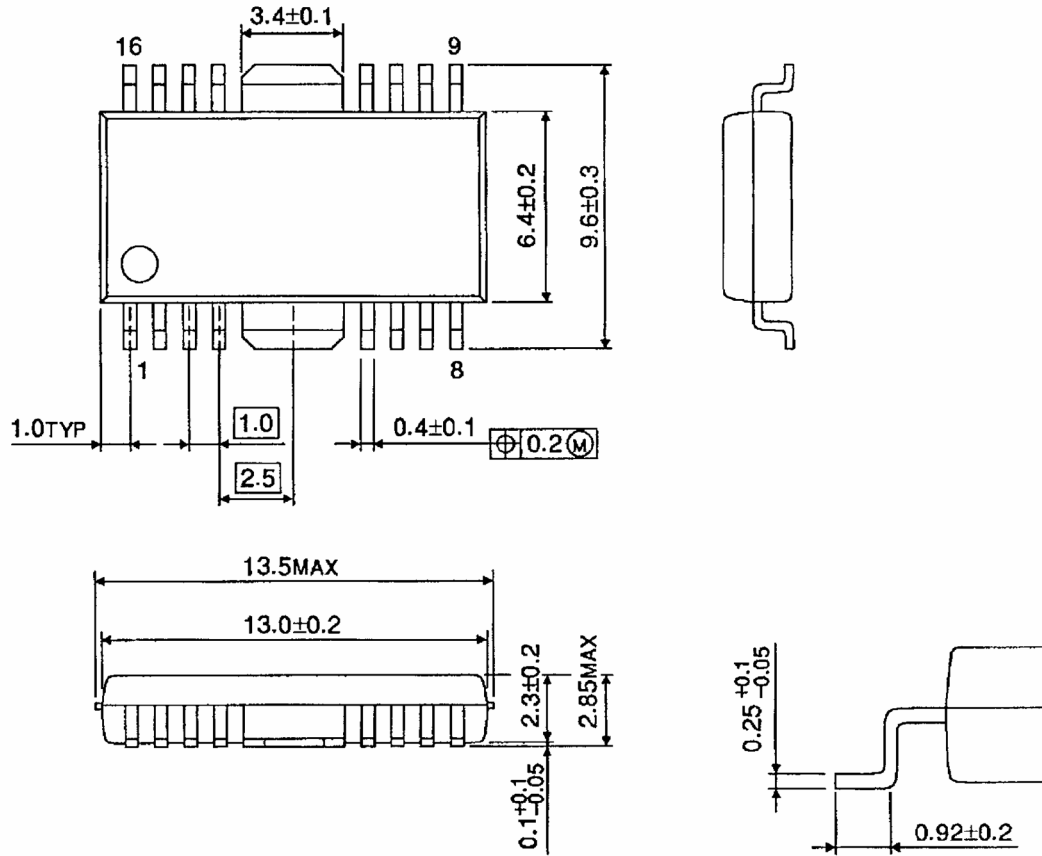

Weight: 0.5 g (typ.)

Notes on Contents**1. Block Diagrams**

Some of the functional blocks, circuits, or constants in the block diagram may be omitted or simplified for explanatory purposes.

2. Equivalent Circuits

The equivalent circuit diagrams may be simplified or some parts of them may be omitted for explanatory purposes.

3. Timing Charts

Timing charts may be simplified for explanatory purposes.

4. Application Circuits

The application circuits shown in this document are provided for reference purposes only.

Thorough evaluation is required, especially at the mass production design stage.

Toshiba does not grant any license to any industrial property rights by providing these examples of application circuits.

5. Test Circuits

Components in the test circuits are used only to obtain and confirm the device characteristics. These components and circuits are not guaranteed to prevent malfunction or failure from occurring in the application equipment.

IC Usage Considerations

Notes on Handling of ICs

- (1) The absolute maximum ratings of a semiconductor device are a set of ratings that must not be exceeded, even for a moment. Do not exceed any of these ratings.
Exceeding the rating(s) may cause the device breakdown, damage or deterioration, and may result injury by explosion or combustion.
- (2) Use an appropriate power supply fuse to ensure that a large current does not continuously flow in case of over current and/or IC failure. The IC will fully break down when used under conditions that exceed its absolute maximum ratings, when the wiring is routed improperly or when an abnormal pulse noise occurs from the wiring or load, causing a large current to continuously flow and the breakdown can lead smoke or ignition. To minimize the effects of the flow of a large current in case of breakdown, appropriate settings, such as fuse capacity, fusing time and insertion circuit location, are required.
- (3) If your design includes an inductive load such as a motor coil, incorporate a protection circuit into the design to prevent device malfunction or breakdown caused by the current resulting from the inrush current at power ON or the negative current resulting from the back electromotive force at power OFF. IC breakdown may cause injury, smoke or ignition.
Use a stable power supply with ICs with built-in protection functions. If the power supply is unstable, the protection function may not operate, causing IC breakdown. IC breakdown may cause injury, smoke or ignition.
- (4) Do not insert devices in the wrong orientation or incorrectly.
Make sure that the positive and negative terminals of power supplies are connected properly. Otherwise, the current or power consumption may exceed the absolute maximum rating, and exceeding the rating(s) may cause the device breakdown, damage or deterioration, and may result injury by explosion or combustion.
In addition, do not use any device that is applied the current with inserting in the wrong orientation or incorrectly even just one time.
- (5) Carefully select external components (such as inputs and negative feedback capacitors) and load components (such as speakers), for example, power amp and regulator.
If there is a large amount of leakage current such as input or negative feedback condenser, the IC output DC voltage will increase. If this output voltage is connected to a speaker with low input withstand voltage, overcurrent or IC failure can cause smoke or ignition. (The over current can cause smoke or ignition from the IC itself.) In particular, please pay attention when using a Bridge Tied Load (BTL) connection type IC that inputs output DC voltage to a speaker directly.

Points to Remember on Handling of ICs

- (1) Heat Radiation Design
In using an IC with large current flow such as power amp, regulator or driver, please design the device so that heat is appropriately radiated, not to exceed the specified junction temperature (T_j) at any time and condition. These ICs generate heat even during normal use. An inadequate IC heat radiation design can lead to decrease in IC life, deterioration of IC characteristics or IC breakdown. In addition, please design the device taking into considerate the effect of IC heat radiation with peripheral components.
- (2) Back-EMF
When a motor rotates in the reverse direction, stops or slows down abruptly, a current flow back to the motor's power supply due to the effect of back-EMF. If the current sink capability of the power supply is small, the device's motor power supply and output pins might be exposed to conditions beyond maximum ratings. To avoid this problem, take the effect of back-EMF into consideration in system design.

RESTRICTIONS ON PRODUCT USE

060116EBA

- The information contained herein is subject to change without notice. 021023_D
- TOSHIBA is continually working to improve the quality and reliability of its products. Nevertheless, semiconductor devices in general can malfunction or fail due to their inherent electrical sensitivity and vulnerability to physical stress. It is the responsibility of the buyer, when utilizing TOSHIBA products, to comply with the standards of safety in making a safe design for the entire system, and to avoid situations in which a malfunction or failure of such TOSHIBA products could cause loss of human life, bodily injury or damage to property.
In developing your designs, please ensure that TOSHIBA products are used within specified operating ranges as set forth in the most recent TOSHIBA products specifications. Also, please keep in mind the precautions and conditions set forth in the "Handling Guide for Semiconductor Devices," or "TOSHIBA Semiconductor Reliability Handbook" etc. 021023_A
- The TOSHIBA products listed in this document are intended for usage in general electronics applications (computer, personal equipment, office equipment, measuring equipment, industrial robotics, domestic appliances, etc.). These TOSHIBA products are neither intended nor warranted for usage in equipment that requires extraordinarily high quality and/or reliability or a malfunction or failure of which may cause loss of human life or bodily injury ("Unintended Usage"). Unintended Usage include atomic energy control instruments, airplane or spaceship instruments, transportation instruments, traffic signal instruments, combustion control instruments, medical instruments, all types of safety devices, etc. Unintended Usage of TOSHIBA products listed in this document shall be made at the customer's own risk. 021023_B
- The products described in this document shall not be used or embedded to any downstream products of which manufacture, use and/or sale are prohibited under any applicable laws and regulations. 060106_Q
- The information contained herein is presented only as a guide for the applications of our products. No responsibility is assumed by TOSHIBA for any infringements of patents or other rights of the third parties which may result from its use. No license is granted by implication or otherwise under any patent or patent rights of TOSHIBA or others. 021023_C
- The products described in this document are subject to the foreign exchange and foreign trade laws. 021023_E