

**Preliminary**

TOSHIBA BiCD Processor IC Silicon Monolithic

**T B 6 2 2 0 9 F**

## Stepping Motor Driver IC Using PWM Chopper Type

The TB62209F is a stepping motor driver driven by chopper micro-step pseudo sine wave.

The TB62209F integrates a decoder for CLK input in micro steps as a system to facilitate driving a two-phase stepping motor using micro-step pseudo sine waves. Micro-step pseudo sine waves are optimal for driving stepping motors with low-torque ripples and at low oscillation. Thus, the TB62209F can easily drive stepping motors with low-torque ripples and at high efficiency.

Also, TB62209F consists output steps by DMOS (Power MOS FET), and that makes possible to control the output power dissipation much lower than ordinary IC with bipolar transistor output.

The IC supports Mixed Decay mode for switching the attenuation ratio at chopping. The switching time for the attenuation ratio can be switched in four stages according to the load.

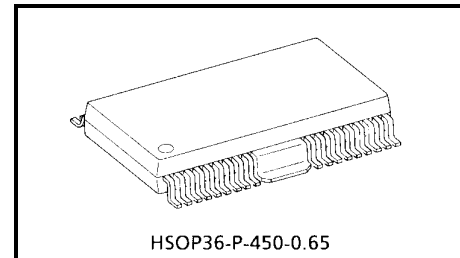

Weight: g (typ.)

**Features**

- Bipolar stepping motor can be controlled by a single driver IC
- Monolithic BiCD IC
- Low ON-resistance of  $R_{on} = 0.5 \Omega$  ( $T_j = 25^\circ\text{C}$  @1.0 A: typ.)
- Built-in decoder and 4-bit DA converters for micro steps
- Built-in ISD, TSD, VDD & VM power monitor (reset) circuit for protection
- Built-in charge pump circuit (two external capacitors)
- 36-pin power flat package (HSOP36-P-450-0.65)
- Output voltage: 40 V max
- Output current: 1.8 A/phase max
- 2-phase, 1-2 (type 2) phase, W1-2 phase, 2W1-2 phase, 4W1-2 phase, or motor lock mode can be selected.
- Built-in Mixed Decay mode enables specification of four-stage attenuation ratio.
- Chopping frequency can be set by external resistors and capacitors.  
High-speed chopping possible at 100 kHz or higher.

Note: When using the IC, pay attention to thermal conditions. These devices are easy damage by high static voltage. In regards to this, please handle with care.

Block Diagram

1. Overview

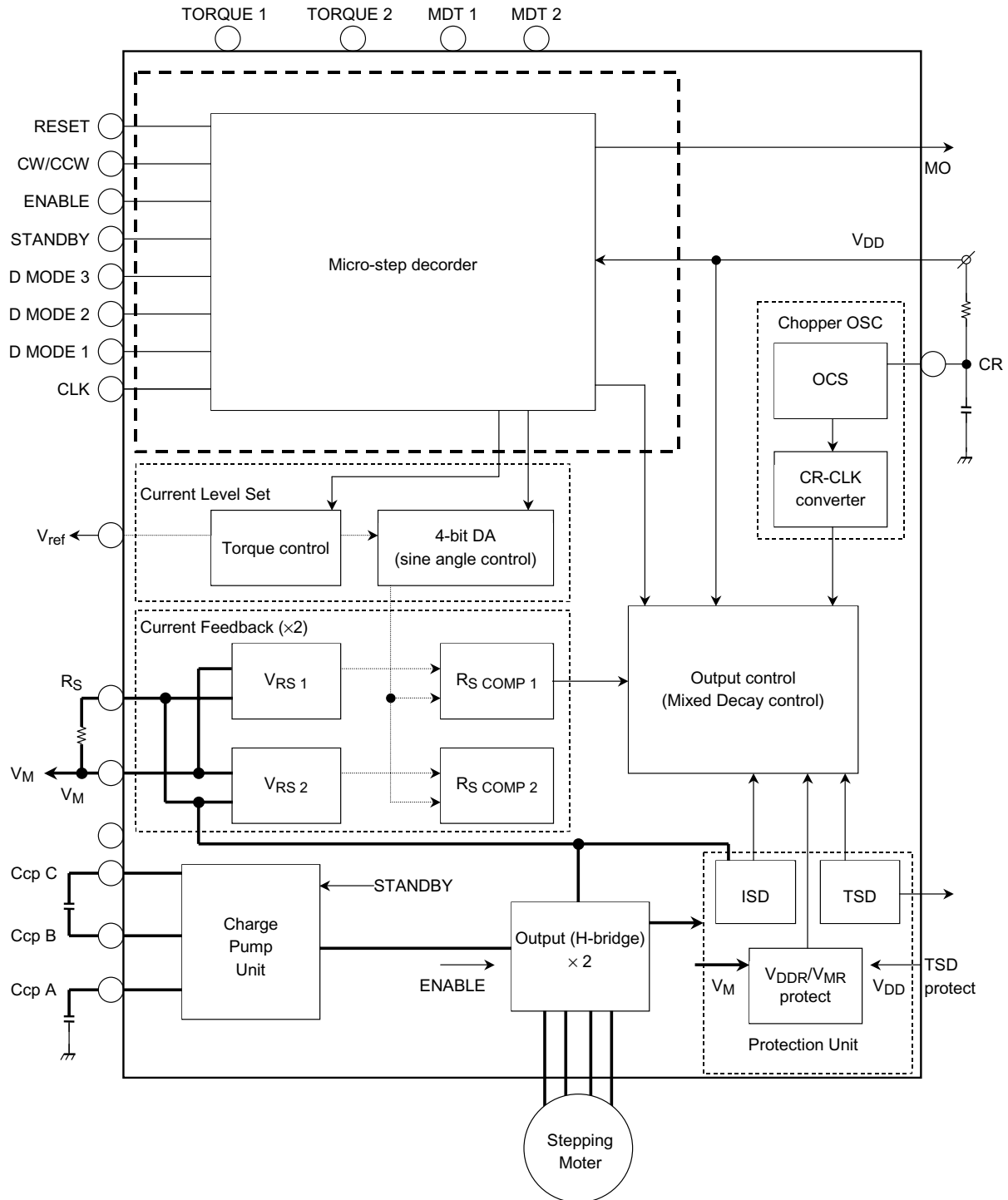

**2. LOGIC UNIT A/B (C/D unit is the same as A/B unit)**

Function

This circuit is used to input from the DATA pins micro-step current setting data and to transfer them to the subsequent stage. By switching the SETUP pin, the data in the mixed decay timing table can be overwritten.

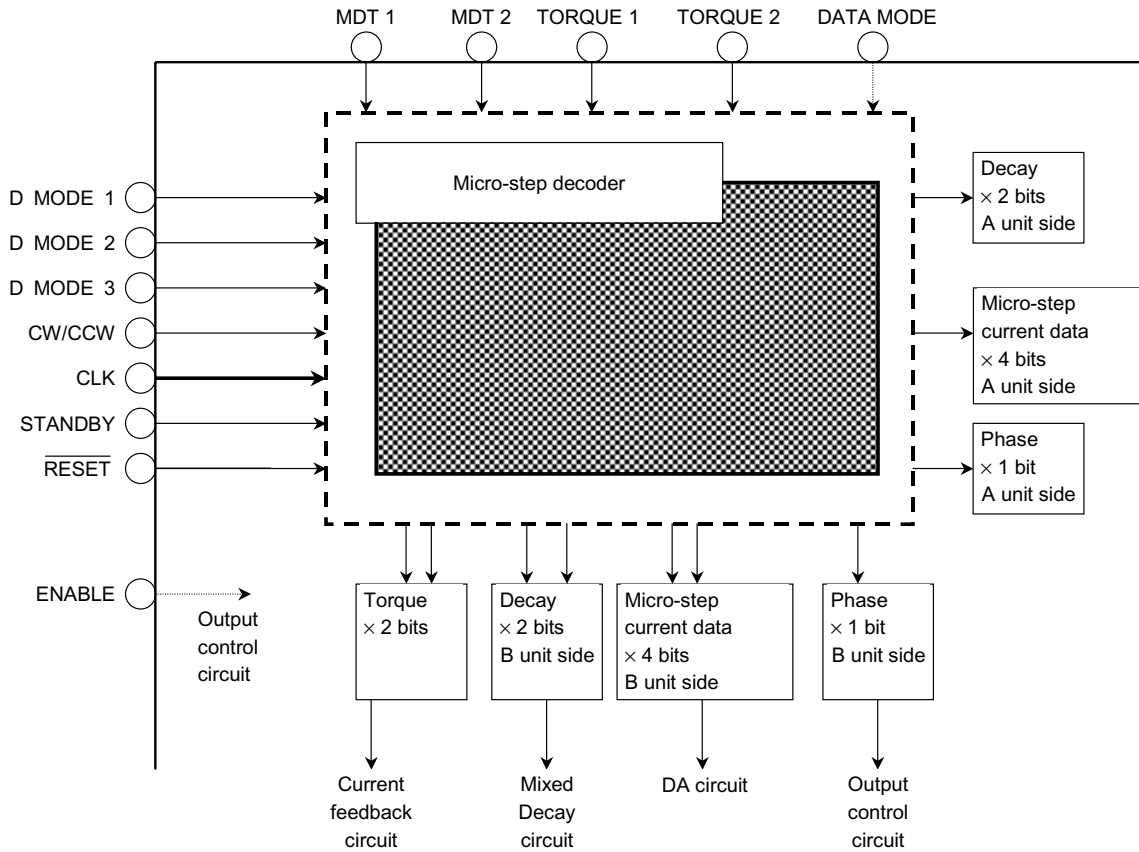

### 3. Current feedback circuit and current setting circuit

Function

The current setting circuit is used to set the reference voltage of the output current using the current setting decoder.

The current feedback circuit is used to output to the output control circuit the relation between the set current value and output current. This is done by comparing the reference voltage output to the current setting circuit with the potential difference generated when current flows through the current sense resistor connected between  $R_S$  and  $V_M$ .

The chopping waveform generator circuit to which CR is connected is used to generate clock used as reference for the chopping frequency.

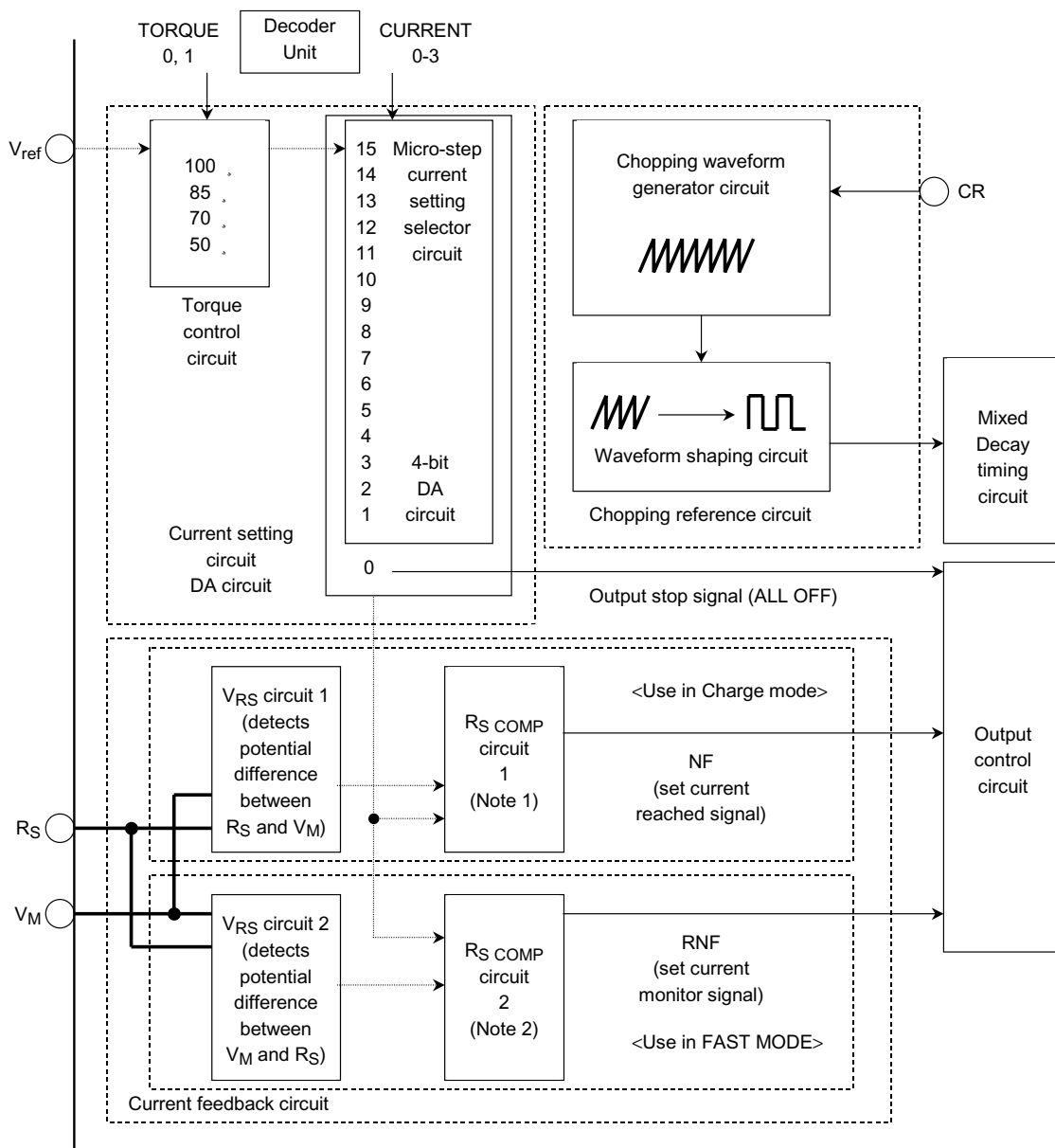

Note 1:  $R_S$  COMP1: Compares the set current with the output current and outputs a signal when the output current reaches the set current.

Note 2:  $R_S$  COMP2: Compares the set current with the output current at the end of Fast mode during chopping. Outputs a signal when the set current is below the output current.

4. Output control circuit, current feedback circuit and current setting circuit

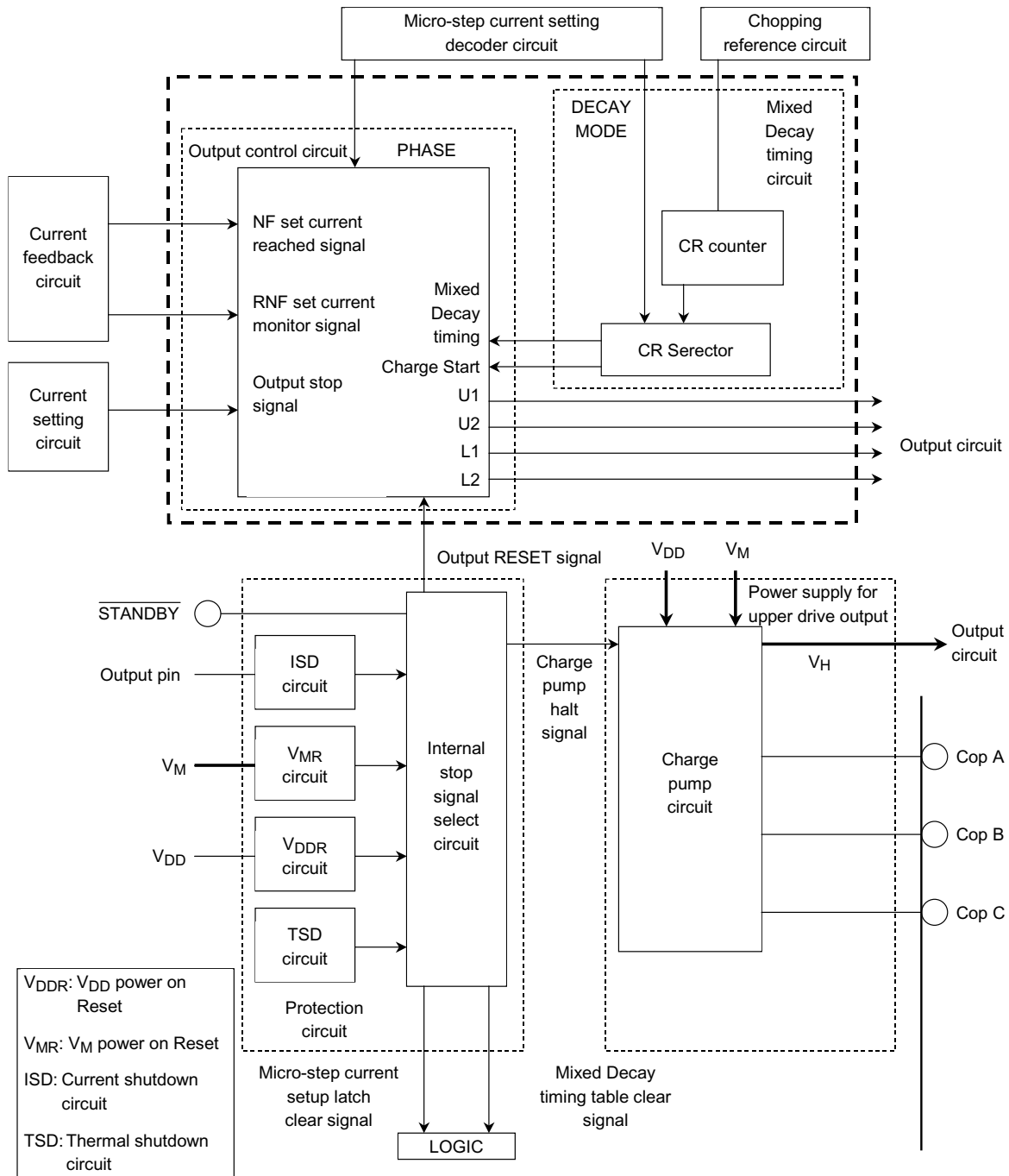

Note: The STANDBY pins are pulled down in the IC by 10-kΩ resistor.  
When not using the pin, connect it to GND. Otherwise, malfunction may occur.

**5. Output equivalent circuit (A/B unit (C/D unit is the same as A/B unit))**

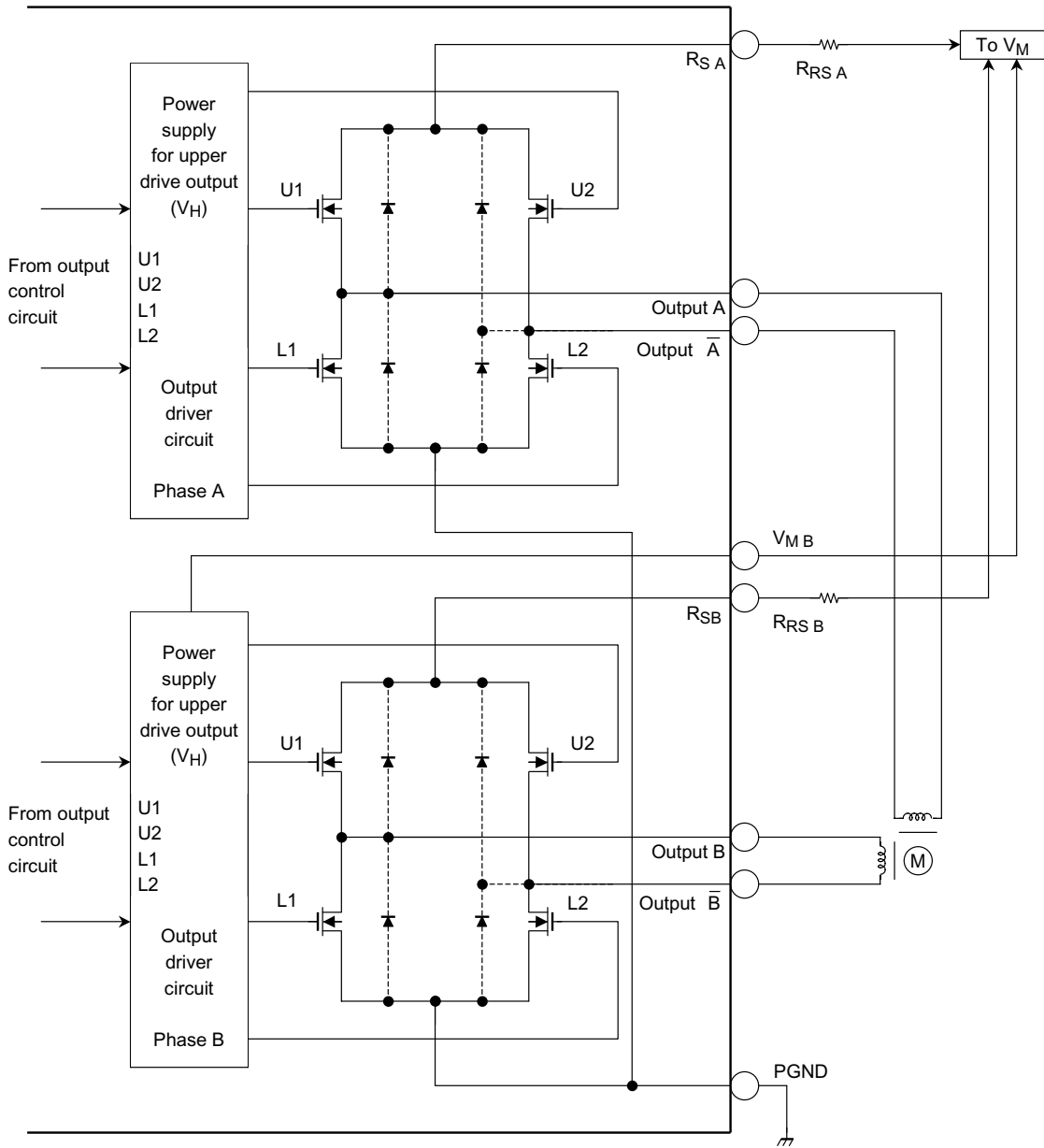

Note: The diode on the dotted line is parasitic diode.

**6. Input equivalent circuit**

**1. Input circuit (CLK, TORQUE, MDT, CW/CCW, DATA MODE, Decay Mode)**

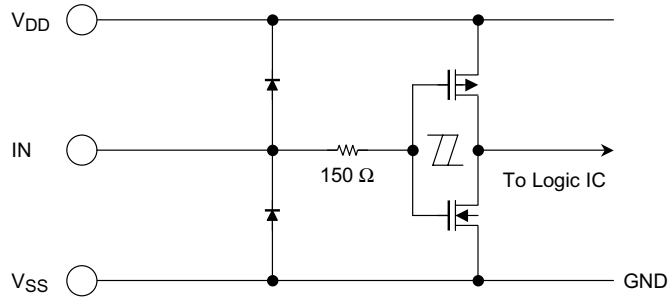

**2. Input circuit ( $\overline{\text{RESET}}$ , ENABLE, STANDBY)**

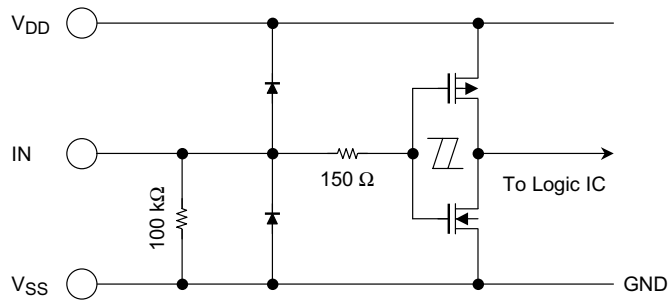

**3.  $V_{\text{ref}}$  input circuit**

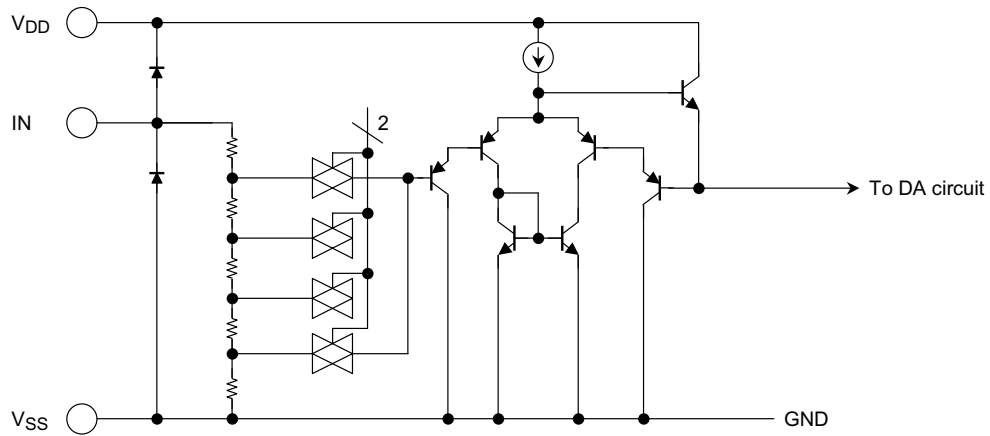

**4. Output circuit (MO, PROTECT)**

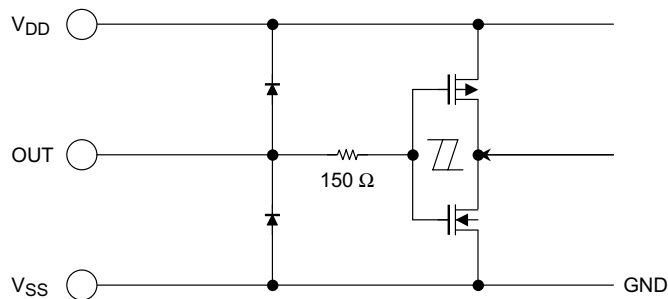

## Pin Assignment (top view)

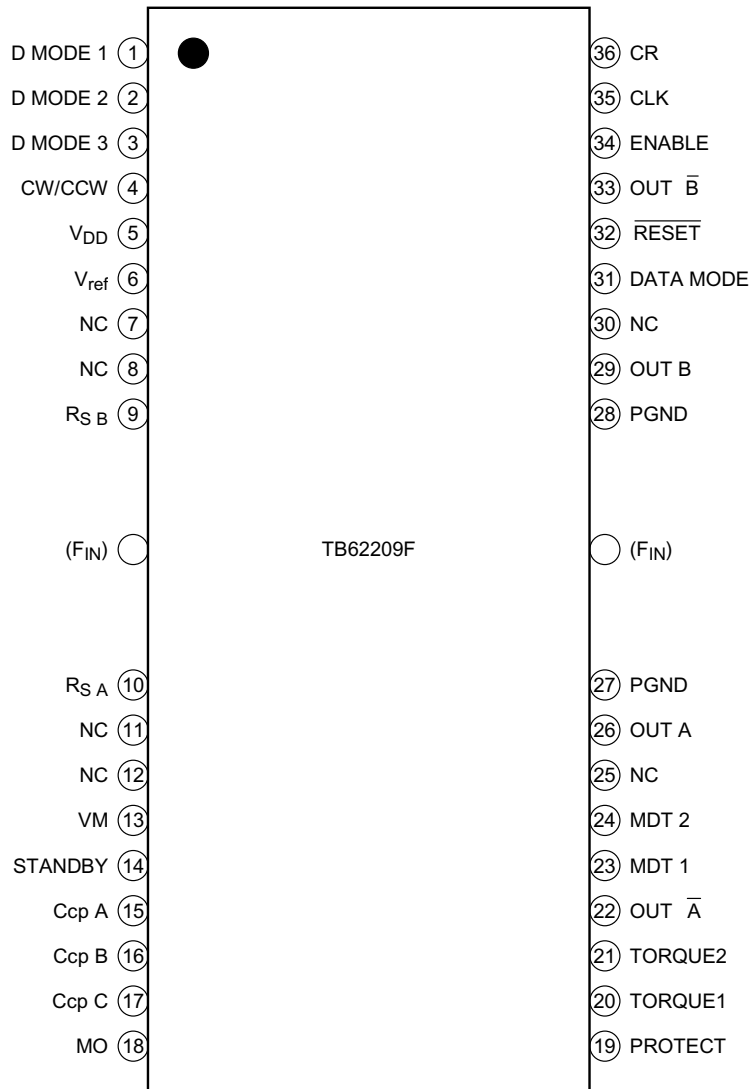

## Pin Assignment for PWM in Data Mode

D MODE 1 → GA+ (OUT A,  $\bar{A}$ )  
 D MODE 2 → GA- (OUT A,  $\bar{A}$ )  
 D MODE 3 → GB+ (OUT B,  $\bar{B}$ )  
 CW/CCW → GB- (OUT B,  $\bar{B}$ )

Note: Pin assignment above is different at data mode and PWM.



## Pin Description 1

Pin Number	Symbol	Function	Remarks
1	D MODE 1	Motor drive mode setting pin	D MODE 3, 2, 1 = LLL: Same function as that of STANDBY pin LLH: Motor Lock mode
2	D MODE 2		LHL: 2-Phase Excitation mode LHH: 1-2 Phase Excitation (A) mode HLL: 1-2 Phase Excitation (B) mode
3	D MODE 3		HLH: W1-2 Phase Excitation mode HHL: 2W1-2 Phase Excitation mode HHH: 4W1-2 Phase Excitation mode
4	CW/CCW	Sets motor rotation direction	CW: Forward rotation CCW: Reverse rotation
5	V <sub>DD</sub>	Logic power supply connecting pin	Connect to logic power supply (5 V).
6	V <sub>ref</sub>	Reference power supply pin for setting output current	Connect to supply voltage for setting current.
7	NC	Not connected	Not wired
8	NC	Not connected	Not wired
9	R <sub>S B</sub>	Unit-B power supply pin (connecting pin for power detection resistor)	Connect current sensing resistor between this pin and V <sub>M</sub> .
F <sub>IN</sub>	F <sub>IN</sub>	FIN Logic ground pin	Connect to power ground. The pin functions as a heat sink. Design pattern taking heat into consideration.
10	R <sub>S A</sub>	Unit-A power supply pin (pin connecting power detection resistor)	Connect current sensing resistor between this pin and V <sub>M</sub> .
11	NC	Not connected	Not wired
12	NC	Not connected	Not wired

## Pin Assignment for PWM in Data Mode

D MODE 1 → GA+ (OUT A,  $\bar{A}$ )

D MODE 2 → GA- (OUT A,  $\bar{A}$ )

D MODE 3 → GB+ (OUT B,  $\bar{B}$ )

CW/CCW → GB- (OUT B,  $\bar{B}$ )

**Pin Description 2**

Pin Number	Symbol	Function	Remarks
13	V <sub>M</sub>	Motor power supply monitor pin	Connect to motor power supply.
14	$\overline{\text{STANDBY}}$	All-function-initializing and Low Power Dissipation mode pin	H: Normal operation L: Operation halted Charge pump output halted
15	Ccp A	Pin connecting capacitor for boosting output stage drive power supply (storage side connected to GND)	Connect capacitor for charge pump (storage side) V <sub>M</sub> and V <sub>DD</sub> are generated.
16	Ccp B	Pin connecting capacitor for boosting output stage drive power supply	Connect capacitor for charge pump (charging side) between this pin and Ccp C.
17	Ccp C	(charging side)	Connect capacitor for charge pump (charging side between this pin and Ccp B.
18	MO	Electrical angle (0°) monitor pin	Outputs High level in 4W1-2, 2W1-2, W1-2, or 1-2 Phase Excitation mode with electrical angle of 0° (phase B: 100%, phase A: 0%). In 2-Phase Excitation mode, outputs High level with electrical angle of 0° (phase B: 100%, phase A: 100%).
19	PROTECT	TSD operation detector pin	Detects thermal shut down (TSD) and outputs High level.
20	TORQUE 1	Motor torque switch setting pin	Torque 2, 1 = HH: 100% LH: 85%  HL: 70% LL: 50%
21	TORQUE 2		
22	OUT $\bar{A}$	Channel $\bar{A}$ output pin	—
23	MDT 2	Mixed Decay mode setting pins	MDT 2, 1 = HH: 100% HL: 75%  LH: 37.5% LL: 12.5%
24	MDT 1		

**Pin Description 3**

Pin Number	Symbol	Function	Remarks
25	NC	Not connected	Not wired
26	OUT A	Channel A output pin	—
27	PGND	Power ground pin	Connect all power ground pins and V <sub>SS</sub> to GND.
F <sub>IN</sub>	F <sub>IN</sub>	Logic ground pin	The pin functions as a heat sink. Design pattern taking heat into consideration.
28	PGND	Power ground pin	Connect all power ground pins to GND.
29	OUT B	Channel B output pin	—
30	NC	Not connected	Not wired
31	DATA MODE	Clock input and PWM	H: Controls external PWM. L: CLK-IN mode We recommend this pin normally be used as CLK-IN mode pin (Low). In PWM mode, functions such as constant current control do not operate.
32	RESET	Initializes electrical angle.	Forcibly initializes electrical angle. At this time we recommend ENABLE pin be set to Low to prevent misoperation. H: Resets electrical angle. L: Normal operation
33	OUT $\bar{B}$	Channel $\bar{B}$ output pin	—
34	ENABLE	Output enable pin	Forcibly turns all output transistors off.
35	CLK	Inputs CLK for determining number of motor rotations.	Electrical angle is incremented by one for each CLK input. CLK is reflected at rising edge.
36	CR	Chopping reference frequency reference pin (for setting chopping frequency)	Determines chopping frequency.

## 1. Function of CW/CCW

CW/CCW switches the direction of stepping motor rotation.

Input	Function
H	Forward (CW)
L	Reverse (CCW)

## 2. Function of MDT 1/MDT 2

MDT 1/MDT 2 specifies the current attenuation speed at constant current control.

The larger the rate (%), the larger the attenuation of the current. Also, the peak current value (current ripple) becomes larger. (Typical value is 37.5%.)

MDT 2	MDT 1	Function
L	L	12.5% Mixed Decay mode
L	H	37.5% Mixed Decay mode
H	L	75% Mixed Decay mode
H	H	100% Mixed Decay mode (Fast Decay mode)

## 3. Function of TORQUE X

TORQUE X changes the current peak value in four steps. Used to change the value of the current used, for example, at startup and fixed-speed rotation.

TORQUE 2	TORQUE 1	Comparator Reference Voltage
H	H	100%
L	H	85%
H	L	70%
L	L	50%

## 4. Function of RESET (forced initialization of electrical angle)

With the CLK input method (decoder method), unless CLKs are counted, except MO, where the electrical angle is at that time is not known. Thus, this method is used to forcibly initialize the electrical angle.

For example, used to change the excitation mode to another drive mode during output from MO (electrical angle = 0°).

Input	Function
H	Initializes electrical angle to 0°
L	Normal operation

**5. Function of ENABLE (output operation)**

ENABLE forcibly turns OFF all output transistors at operation.  
Data such as electrical angle and operating mode are all retained.

Input	Function
H	Operation enabled (active)
L	Output halted (operation other than output active)

**6. Function of STANDBY**

STANDBY halts the charge pump circuit (power supply booster circuit) as well as halting output.  
We recommend setting to Standby mode at power on.  
(At this time, data on the electrical angle are retained.)

Input	Function
H	Operation enabled (active)
L	Output halted (Low Power Dissipation mode) Charge pump halted

**7. Functions of Excitation Modes**

	Excitation Mode	DM3	DM2	DM1	Remarks
1	Low Power Dissipation mode	0	0	0	Standby mode Charge pump halted
2	Motor Lock mode	0	0	1	Locks only at 0° electrical angle.
3	2-Phase Excitation mode	0	1	0	45° → 135° → 225° → 315° → 45°
4	1-2 Phase Excitation (A)	0	1	1	Low-torque, 1-bit micro-step change
5	1-2 Phase Excitation (B)	1	0	0	High-torque, 1-bit micro-step change
6	W1-2 Phase Excitation	1	0	1	2-bit micro-step change
7	2W1-2 Phase Excitation	1	1	0	3-bit micro-step change
8	4W1-2 Phase Excitation	1	1	1	4-bit micro-step change

**8. Function of DATA MODE**

DATA MODE switches external duty control (forced PWM control) and constant current CLK-IN control. In Phase mode, H-bridge can be forcibly inverted and output only can be turned off. Constant current drive including micro-step drive can only be controlled in CLK-IN mode.

Input	Function
H	PHASE MODE
L	CLK-IN MODE

Note 1: Normally, use CLK-IN mode.

**9. Electrical Angle Setting immediately after Initialization**

In Initialize mode (immediately after RESET is released), the following currents are set.

In Low Power Dissipation mode, the internal decoder continues incrementing the electrical angle but current is not output.

Note that the initial electrical angle value in 2-Phase Excitation mode differs from that in nW1-2 (n = 0, 1, 2, 4) Phase Excitation mode.

	Excitation Mode	IB (%)	IA (%)	Remarks
1	Low Power Dissipation mode	100	0	Electrical angle incremented but no current output
2	Motor Lock mode	100	0	Electrical angle incremented but no motor rotation due to no IA output
3	2-Phase Excitation	100	100	45°
4	1-2 Phase Excitation (A)	100	0	0°
5	1-2 Phase Excitation (B)	100	0	0°
6	W1-2 Phase Excitation	100	0	0°
7	2W1-2 Phase Excitation	100	0	0°
8	4W1-2 Phase Excitation	100	0	0°

Note 2: Where, IB = 100% and IA = 0%, the electrical angle is 0°. Where, IB = 0% and IA = 100%, the electrical angle is +90°.

**10. Function of DATA MODE (Phase A mode used for explanation)**

DATA MODE inputs the external PWM signal (duty signal) and controls the current. Functions such as constant current control and overcurrent protector do not operate.

Use this mode only when control cannot be performed in CLK-IN mode.

	GA+	GA-	Output State
(1)	L	L	Output off
(2)	L	H	A+ phase: Low A- phase: High
(3)	H	L	A+ phase: High A- phase: Low
(4)	H	H	Output off

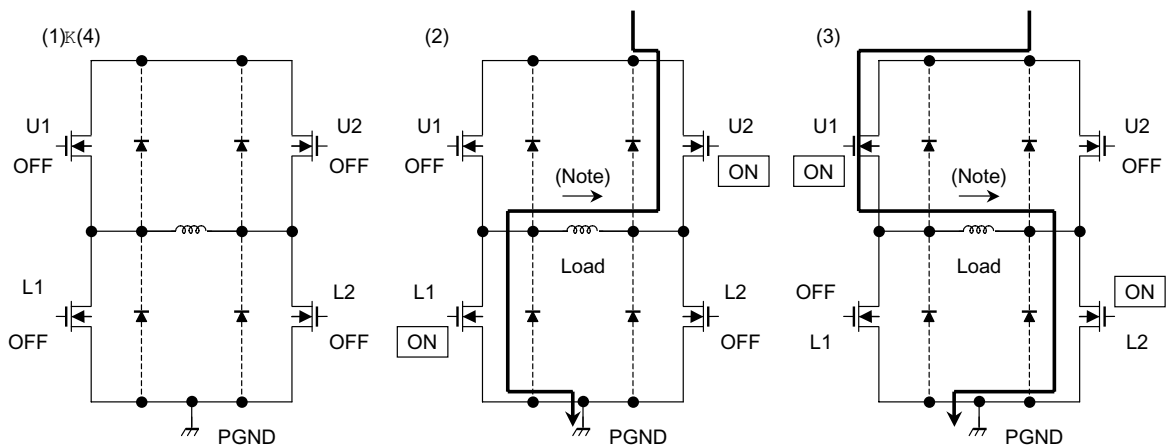

Note: Output is off at (1) and (4).

- D MODE 1 → GA+ (OUT A,  $\bar{A}$ )
- D MODE 2 → GA- (OUT A,  $\bar{A}$ )
- D MODE 3 → GB+ (OUT B,  $\bar{B}$ )
- CW/CCW → GB- (OUT B,  $\bar{B}$ )

**Maximum Ratings (Ta = 25°C)**

Characteristics	Symbol	Rating	Unit
Logic supply voltage	V <sub>DD</sub>	7	V
Motor supply voltage	V <sub>M</sub>	40	V
Output current (Note 1)	I <sub>OUT</sub>	1.8	A/phase
Current detect pin voltage	V <sub>RS</sub>	V <sub>M</sub> ± 4.5 V	V
Charge pump pin maximum voltage (CCP1 Pin)	V <sub>H</sub>	V <sub>M</sub> + 7.0	V
Logic input voltage (Note 2)	V <sub>IN</sub>	to V <sub>DD</sub> + 0.4	V
Power dissipation	(Note 3)	1.4	W
	(Note 4)	3.2	
Operating temperature	T <sub>opr</sub>	-40 to 85	°C
Storage temperature	T <sub>stg</sub>	-55 to 150	°C
Junction temperature	T <sub>j</sub>	150	°C

Note 1: Perform thermal calculations for the maximum current value under normal conditions. Use the IC at 1.5 A or less per phase.

The current value maybe controled according to the ambient temperature or board conditions.

Note 2: Input 7 V or less as V<sub>IN</sub>.

Note 3: Measured for the IC only. (Ta = 25°C)

Note 4: Measured when mounted on the board. (Ta = 25°C)

Ta: IC ambient temperature

T<sub>opr</sub>: IC ambient temperature when starting operation

T<sub>j</sub>: IC chip temperature during operation T<sub>j</sub> (max) is controlled by TSD (thermal shut down circuit)

**Recommended Operating Conditions (Ta = 0 to 85°C, (Note 5))**

Characteristics	Symbol	Test Condition	Min	Typ.	Max	Unit
Power supply voltage	V <sub>DD</sub>	—	4.5	5.0	5.5	V
Motor supply voltage	V <sub>M</sub>	V <sub>DD</sub> = 5.0 V, Ccp1 = 0.22 μF, Ccp2 = 0.02 μF	20	24	34	V
Output current	I <sub>OUT</sub> (1)	Ta = 25°C, per phase	—	1.2	1.5	A
Logic input voltage	V <sub>IN</sub>	—	GND	—	V <sub>DD</sub>	V
Clock frequency	f <sub>CLK</sub>	V <sub>DD</sub> = 5.0 V	—	1.0	150	KHz
Chopping frequency	f <sub>chop</sub>	V <sub>DD</sub> = 5.0 V	50	100	150	KHz
Reference voltage	V <sub>ref</sub>	V <sub>M</sub> = 24 V, Torque = 100%	2.0	3.0	V <sub>DD</sub>	V
Current detect pin voltage	V <sub>RS</sub>	V <sub>DD</sub> = 5.0 V	0	±1.0	±4.5	V

Note 5: Because the maximum value of T<sub>j</sub> is 120°C, recommended maximum current usage is below 120°C.



**Electrical Characteristics 1 (unless otherwise specified, Ta = 25°C, V<sub>DD</sub> = 5 V, V<sub>M</sub> = 24 V)**

Characteristics		Symbol	Test Circuit	Test Condition	Min	Typ.	Max	Unit
Input voltage	HIGH	V <sub>IN (H)</sub>	—	Data input pins	2.0	V <sub>DD</sub>	V <sub>DD</sub> + 0.4	V
	LOW	V <sub>IN (L)</sub>			GND - 0.4	GND	0.8	
Input hysteresis voltage		V <sub>IN (HIS)</sub>	—	Data input pins	200	400	700	mV
Input current 1		I <sub>IN (H)</sub>	—	Data input pins with resistor	—	—	1.0	μA
		I <sub>IN (H)</sub>		Data input pins without resistor	35	50	75	
		I <sub>IN (L)</sub>			—	—	1.0	
Power dissipation (V <sub>DD</sub> Pin)		I <sub>DD1</sub>	—	V <sub>DD</sub> = 5 V (STROBE, RESET, DATA = L), RESET = L, Logic, output all off	1.0	2.0	3.0	mA
		I <sub>DD2</sub>		Output OPEN, f <sub>CLK</sub> = 1.0 kHz LOGIC ACTIVE, V <sub>DD</sub> = 5 V, Charge Pump = charged	1.0	2.5	3.5	
Power dissipation (V <sub>M</sub> Pin)		I <sub>M1</sub>	—	Output OPEN (STROBE, RESET, DATA = L), RESET = L, Logic, output all off, Charge Pump = no operation	1.0	2.0	3.0	mA
		I <sub>M2</sub>		Output OPEN, f <sub>CLK</sub> = 1 kHz LOGIC ACTIVE, V <sub>DD</sub> = 5 V, V <sub>M</sub> = 24 V, Output off, Charge Pump = charged	2.0	4.0	5.0	
		I <sub>M3</sub>		Output OPEN, f <sub>CLK</sub> = 4 kHz LOGIC ACTIVE, 100 kHz chopping (emulation), Output OPEN, Charge Pump = charged	—	10	13	
Output standby current	Upper	I <sub>OH</sub>	—	V <sub>RS</sub> = V <sub>M</sub> = 24 V, V <sub>OUT</sub> = 0 V, STANDBY = H, RESET = L, CLK = L	-200	-150	—	μA
Output bias current	Upper	I <sub>OB</sub>	—	V <sub>OUT</sub> = 0 V, STANDBY = H, RESET = L, CLK = L	-100	-50	—	μA
Output leakage current	Lower	I <sub>OL</sub>	—	V <sub>RS</sub> = V <sub>M</sub> = CcpA = V <sub>OUT</sub> = 24 V, LOGIC IN = ALL = L	—	1.0	1.0	μA
Comparator reference voltage ratio	HIGH (Reference)	V <sub>RS (H)</sub>	—	V <sub>ref</sub> = 3.0 V, V <sub>ref</sub> (Gain) = 1/5.0 TORQUE = (H) = 100% set	—	100	—	%
	MID HIGH	V <sub>RS (MH)</sub>		V <sub>ref</sub> = 3.0 V, V <sub>ref</sub> (Gain) = 1/5.0 TORQUE = (MH) = 85% set	83	85	87	
	MID LOW	V <sub>RS (ML)</sub>		V <sub>ref</sub> = 3.0 V, V <sub>ref</sub> (Gain) = 1/5.0 TORQUE = (ML) = 70% set	68	70	72	
	LOW	V <sub>RS (L)</sub>		V <sub>ref</sub> = 3.0 V, V <sub>ref</sub> (Gain) = 1/5.0 TORQUE = (L) = 50% set	48	50	52	
Output current differential		ΔI <sub>OUT1</sub>	—	Differences between output current channels	-5	—	5	%
Output current setting differential		ΔI <sub>OUT2</sub>	—	I <sub>OUT</sub> = 1000 mA	-5	—	5	%
RS pin current		I <sub>RS</sub>	—	V <sub>RS</sub> = 24 V, V <sub>M</sub> = 24 V, RESET = L (RESET state)	—	1	2	μA
Output transistor drain-source ON-resistance		R <sub>ON (D-S) 1</sub>	—	I <sub>OUT</sub> = 1.0 A, V <sub>DD</sub> = 5.0 V, T <sub>j</sub> = 25°C, Drain-Source	—	0.5	0.6	Ω
		R <sub>ON (D-S) 1</sub>		I <sub>OUT</sub> = 1.0 A, V <sub>DD</sub> = 5.0 V, T <sub>j</sub> = 25°C, Source-Drain	—	0.5	0.6	
		R <sub>ON (D-S) 2</sub>		I <sub>OUT</sub> = 1.0 A, V <sub>DD</sub> = 5.0 V, T <sub>j</sub> = 105°C, Drain-Source	—	0.6	0.75	
		R <sub>ON (D-S) 2</sub>		I <sub>OUT</sub> = 1.0 A, V <sub>DD</sub> = 5.0 V, T <sub>j</sub> = 105°C, Source-Drain	—	0.6	0.75	

**Electrical Characteristics 2 (Ta = 25°C, V<sub>DD</sub> = 5 V, V<sub>M</sub> = 24 V, I<sub>OUT</sub> = 1.0 A)**

Characteristics	Symbol	Test Circuit	Test Condition	Min	Typ.	Max	Unit
Chopper current	Vector	—	θA = 90 (θ16)	—	100	—	%
			θA = 84 (θ15)	—	100	—	
			θA = 79 (θ14)	93	98	—	
			θA = 73 (θ13)	91	96	—	
			θA = 68 (θ12)	87	92	97	
			θA = 62 (θ11)	83	88	93	
			θA = 56 (θ10)	78	83	88	
			θA = 51 (θ9)	72	77	82	
			θA = 45 (θ8)	66	71	76	
			θA = 40 (θ7)	58	63	68	
			θA = 34 (θ6)	51	56	61	
			θA = 28 (θ5)	42	47	52	
			θA = 23 (θ4)	33	38	43	
			θA = 17 (θ3)	24	29	34	
			θA = 11 (θ2)	15	20	25	
			θA = 6 (θ1)	5	10	15	
θA = 0 (θ0)	—	0	—				

## Electrical Characteristics 3 (unless otherwise specified, Ta = 25°C, V<sub>DD</sub> = 5 V, V<sub>M</sub> = 24 V)

Characteristics	Symbol	Test Circuit	Test Condition	Min	Typ.	Max	Unit
V <sub>ref</sub> input voltage	V <sub>ref</sub>	9	V <sub>M</sub> = 24 V, V <sub>DD</sub> = 5 V, STANDBY = H, RESET = L, Output on, CLK = 1 kHz	2.0	—	V <sub>DD</sub>	V
V <sub>ref</sub> input current	I <sub>ref</sub>	9	STANDBY = H, RESET = L, Output off, V <sub>M</sub> = 24 V, V <sub>DD</sub> = 5 V, V <sub>ref</sub> = 3.0 V	20	35	50	μA
V <sub>ref</sub> attenuation ratio	V <sub>ref</sub> (GAIN)	—	V <sub>M</sub> = 24 V, V <sub>DD</sub> = 5 V, STANDBY = H, RESET = L, Output on, V <sub>ref</sub> = 2.0 to V <sub>DD</sub> - 1.0 V	1/4.8	1/5.0	1/5.2	—
TSD temperature (Note 1)	T <sub>j</sub> TSD	—	V <sub>DD</sub> = 5 V, V <sub>M</sub> = 24 V	130	—	170	°C
TSD return temperature difference (Note 1)	ΔT <sub>j</sub> TSD	—	T <sub>j</sub> TSD = 130 to 170°C	T <sub>j</sub> TSD - 50	T <sub>j</sub> TSD - 35	T <sub>j</sub> TSD - 20	°C
V <sub>DD</sub> return voltage	V <sub>DDR</sub>	10	V <sub>M</sub> = 24 V, STANDBY = H	2.0	3.0	4.0	V
V <sub>M</sub> return voltage	V <sub>MR</sub>	11	V <sub>DD</sub> = 5 V, STANDBY = H	2.0	3.5	5.0	V
Over current protected circuit operation current (Note 2)	ISD	—	V <sub>DD</sub> = 5 V, V <sub>M</sub> = 24 V	—	3.0	—	A
High temperature monitor pin output current	I <sub>protect</sub>	12	V <sub>DD</sub> = 5 V, TSD = operating condition	1.0	3.0	5.0	mA
Electrical angle monitor pin output current	I <sub>MO</sub>	12	V <sub>DD</sub> = 5 V, electrical angle = 0° (I <sub>B</sub> = 100%, I <sub>A</sub> = 0%)	1.0	3.0	5.0	mA
High temperature monitor pin output voltage	V <sub>protect</sub> (H)	12	V <sub>DD</sub> = 5 V, TSD = operating condition	—	—	—	V
	V <sub>protect</sub> (L)	—	V <sub>DD</sub> = 5 V, TSD = not operating condition	—	—	—	
Electrical angle monitor pin output voltage	V <sub>MO2</sub> (H)	12	V <sub>DD</sub> = 5 V, electrical angle = except 0° (I <sub>B</sub> = 100%, I <sub>A</sub> = Except 0% set)	—	—	—	V
	V <sub>MO2</sub> (L)	—	V <sub>DD</sub> = 5 V, electrical angle = 0° (I <sub>B</sub> = 100%, I <sub>A</sub> = 0%)	—	—	—	

### Note 1: Thermal shut down (TSD) circuit

When the IC junction temperature reaches the specified value and the TSD circuit is activated, the internal reset circuit is activated switching the outputs of both motors to off.

When the temperature is set between 130 (min) to 170°C (max), the TSD circuit operates.

When the TSD circuit is activated, the charge pump is halted, and TROTECT pin outputs V<sub>DD</sub> voltage.

Even if the TSD circuit is activated and Standby goes H → L → H instantaneously, the IC is not reset until the IC junction temperature drops -20°C (typ.) below the TSD operating temperature (hysteresis function).

### Note 2: Overcurrent protection circuit

When current exceeding the specified value flows to the output, the internal reset circuit is activated, and the ISD turns off the output.

Until the Standby signal goes Low to High, the overcurrent protection circuit remains activated.

During ISD, IC turns Standby mode and the charge pump halts.

**AC Characteristics (Ta = 25°C, VM = 24 V, VDD = 5 V, 6.8 mH/5.7 Ω)**

Characteristics	Symbol	Test Circuit	Test Condition	Min	Typ.	Max	Unit
Clock frequency	f <sub>CLK</sub>	—	—	—	—	120	kHz
Minimum clock pulse width	t <sub>w</sub> (t <sub>CLK</sub> )	—	—	100	—	—	μs
	t <sub>wp</sub>	—	—	50	—	—	
	t <sub>wn</sub>	—	—	50	—	—	
Output transistor switching characteristic	t <sub>r</sub>	—	Output Load: 6.8 mH/5.7 Ω	—	100	—	ns
	t <sub>f</sub>	—	—	—	100	—	
	t <sub>pLH</sub>	—	CLK to OUT	—	1000	—	
	t <sub>pHL</sub>	—	Output Load: 6.8 mH/5.7 Ω	—	2000	—	
	t <sub>pLH</sub>	—	CR to OUT	—	500	—	
Transistor switching characteristics (MO, PROTECT)	t <sub>pHL</sub>	—	Output Load: 6.8 mH/5.7 Ω	—	1000	—	ns
	t <sub>r</sub>	—	—	—	20	—	
	t <sub>f</sub>	—	—	—	20	—	
	t <sub>pLH</sub>	—	—	—	20	—	
Noise rejection dead band time	t <sub>BRANK</sub>	—	I <sub>OUT</sub> = 1.0 A	200	300	400	ns
CR reference signal oscillation frequency	f <sub>CR</sub>	—	C <sub>osc</sub> = 560 pF, R <sub>osc</sub> = 3.6 kΩ	—	800	—	kHz
Chopping frequency range	f <sub>chop</sub> (min) f <sub>chop</sub> (max)	—	V <sub>M</sub> = 24 V, V <sub>DD</sub> = 5 V, Output ACTIVE (I <sub>OUT</sub> = 1.0 A) Step fixed, C <sub>cp1</sub> = 0.22 μF, C <sub>cp2</sub> = 0.01 μF	40	100	150	kHz
Chopping frequency	f <sub>chop</sub>	—	Output ACTIVE (I <sub>OUT</sub> = 1.0 A), CR CLK = 800 kHz	—	100	—	kHz
Charge pump rise time	t <sub>ONG</sub>	—	C <sub>cp</sub> = 0.22 μF, C <sub>cp</sub> = 0.01 μF V <sub>M</sub> = 24 V, V <sub>DD</sub> = 5 V, STANDBY = ON → OFF	—	100	200	μs

## 1. Current Waveform and Setting of Mixed Decay Mode

At constant current control, in current amplitude (pulsating current) Decay mode, a point from 0 to 3 can be set using 2-bit parallel data.

NF is the point where the output current reaches the set current value. RNF is the timing for monitoring the set current.

The smaller the MDT value, the smaller the current ripple (peak current value). Note that current decay capability deteriorates.

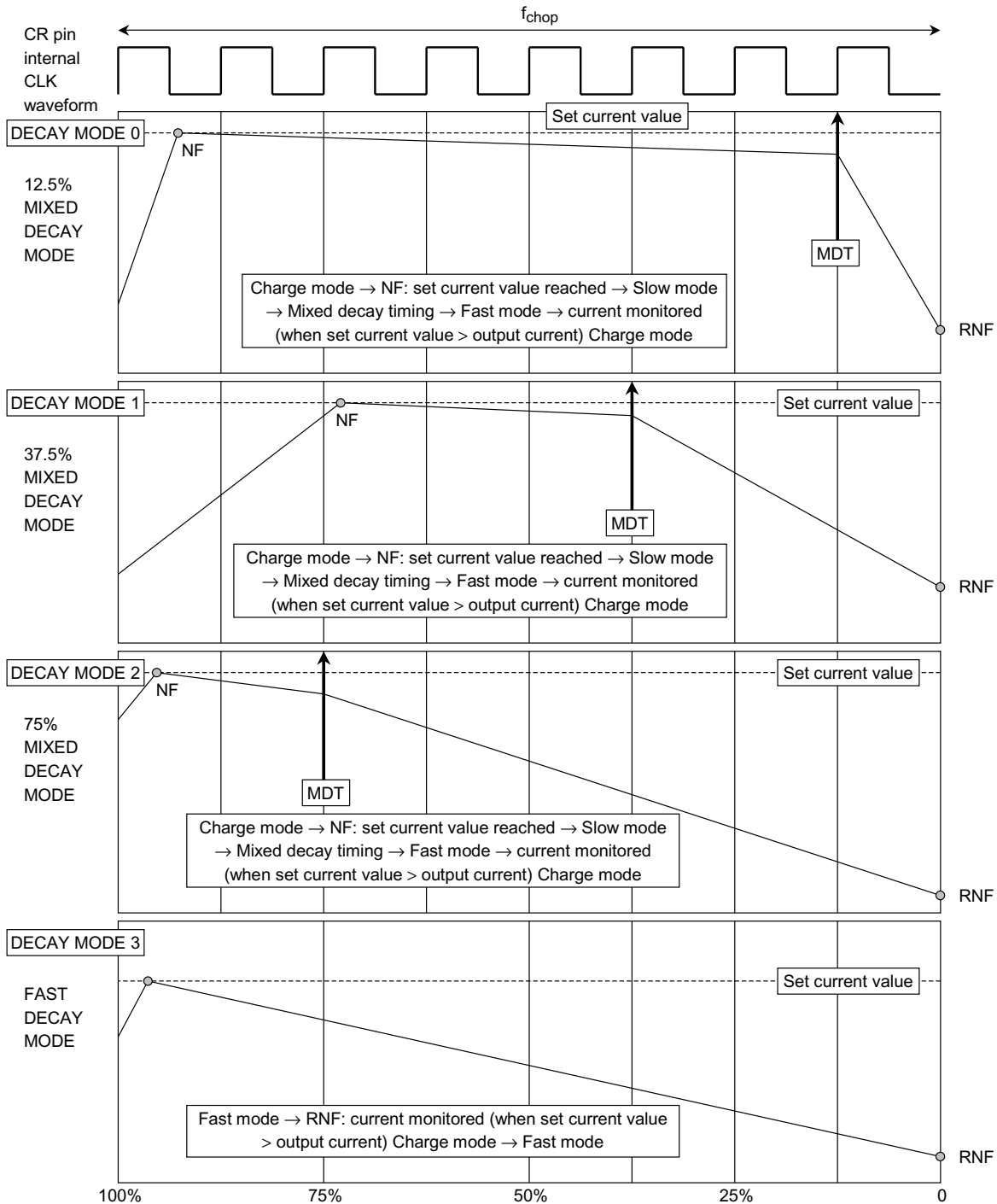

**2. CURRENT MODES  
(MIXED (SLOW + FAST) DECAY MODE Effect)**

- Current value in increasing (Sine wave)

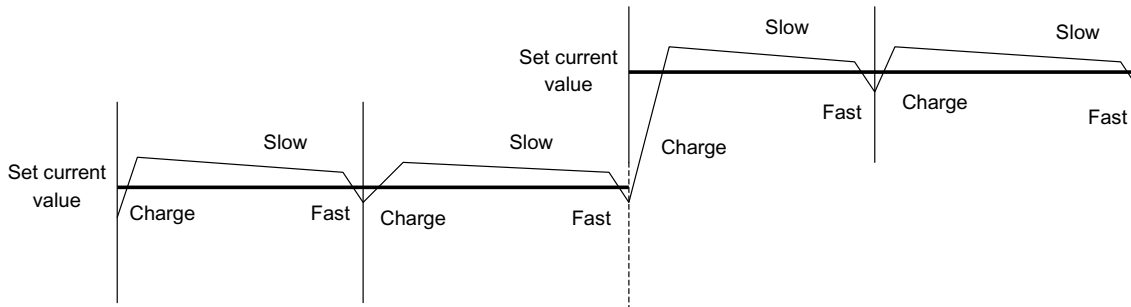

Sine wave in decreasing (When using MIXED DECAY Mode with large attenuation ratio (MDT%) at attenuation)

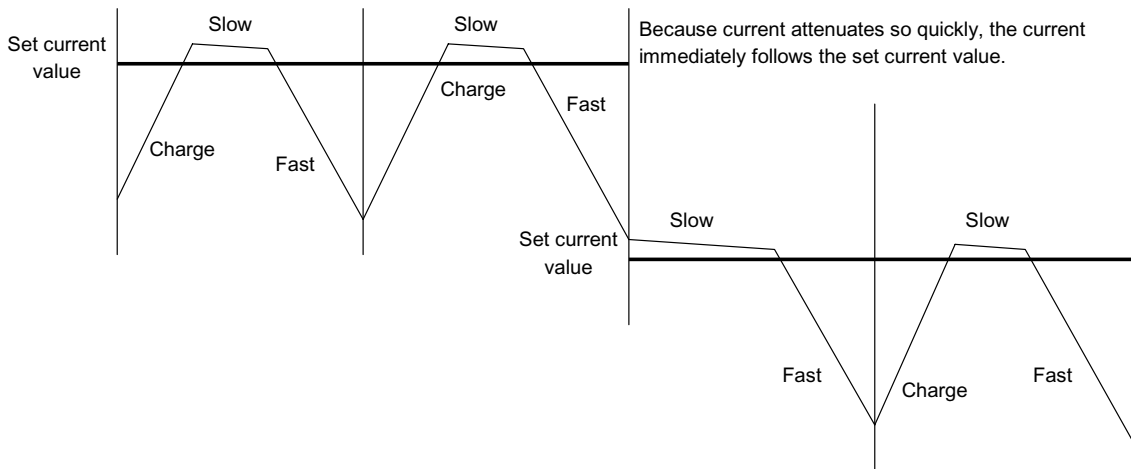

- Sine wave in decreasing (When using MIXED DECAY Mode with small attenuation ratio (MDT%) at attenuation)

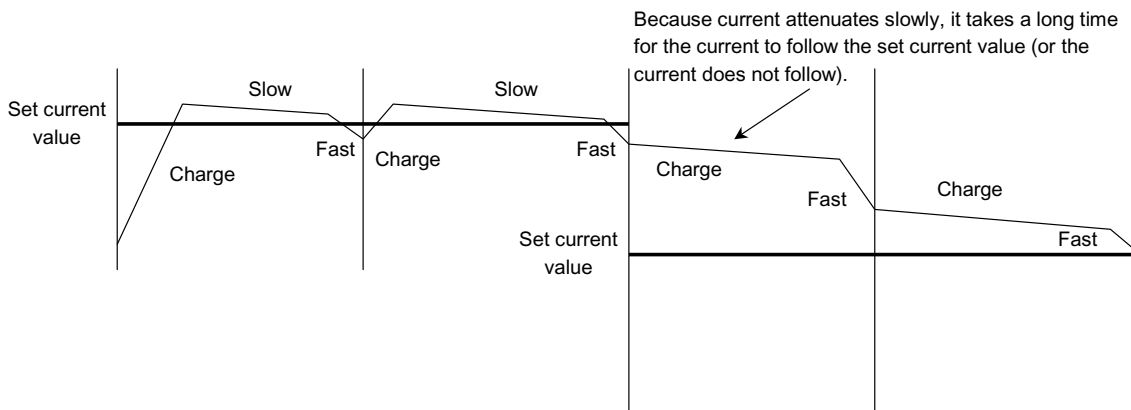

If RNF, current watching point, was the set current value (output current) in the mixed decay mode and in the fast decay mode, there is no charge mode but the slow + fast mode (slow to fast is at MDT) in the next chopping cycle.

Note: The above charts are schematics. The actual current transient responses are curves.

3. MIXED DECAY MODE waveform (Current Waveform)

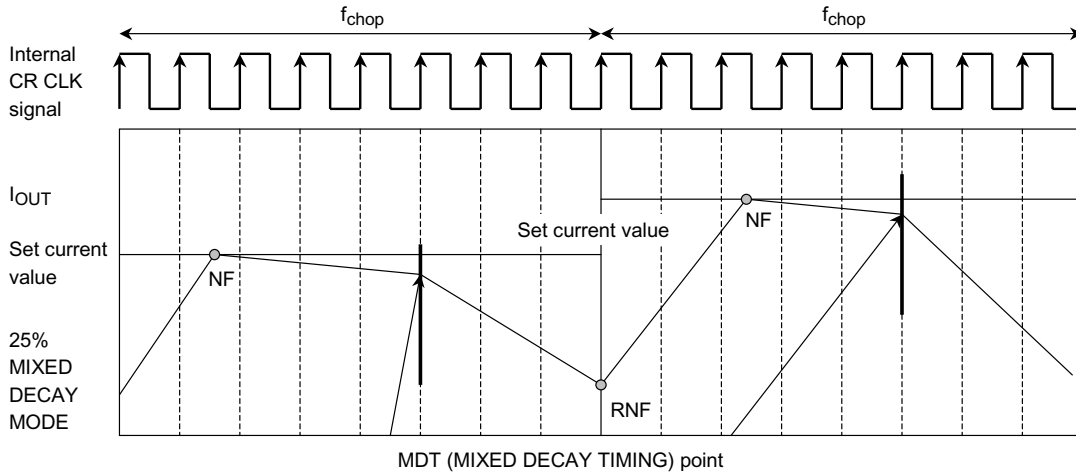

- When NF is after MIXED DECAY TIMING

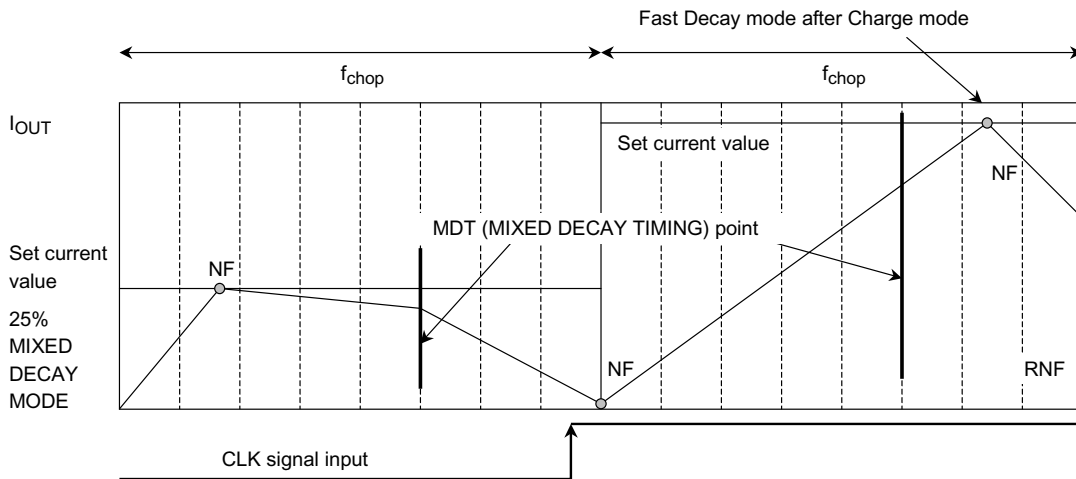

- In MIXED DECAY MODE, when the output current > the set current value

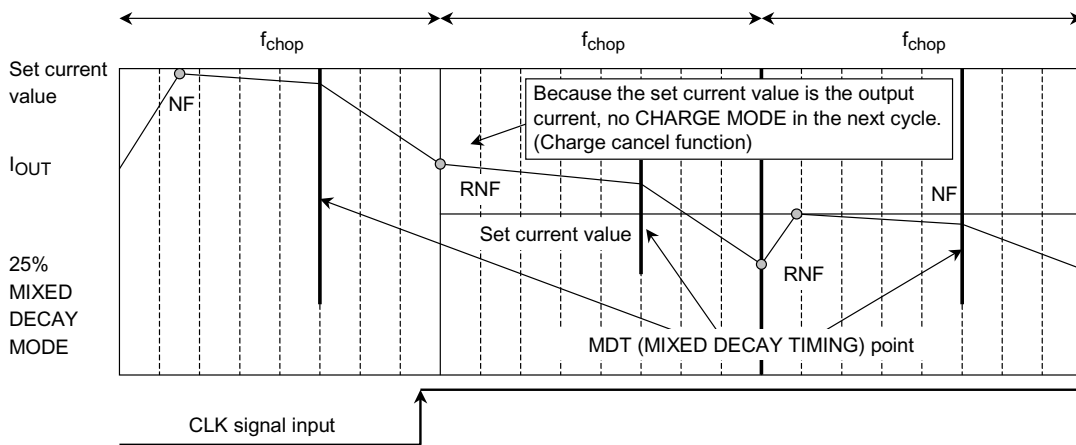

4. FAST DECAY MODE waveform

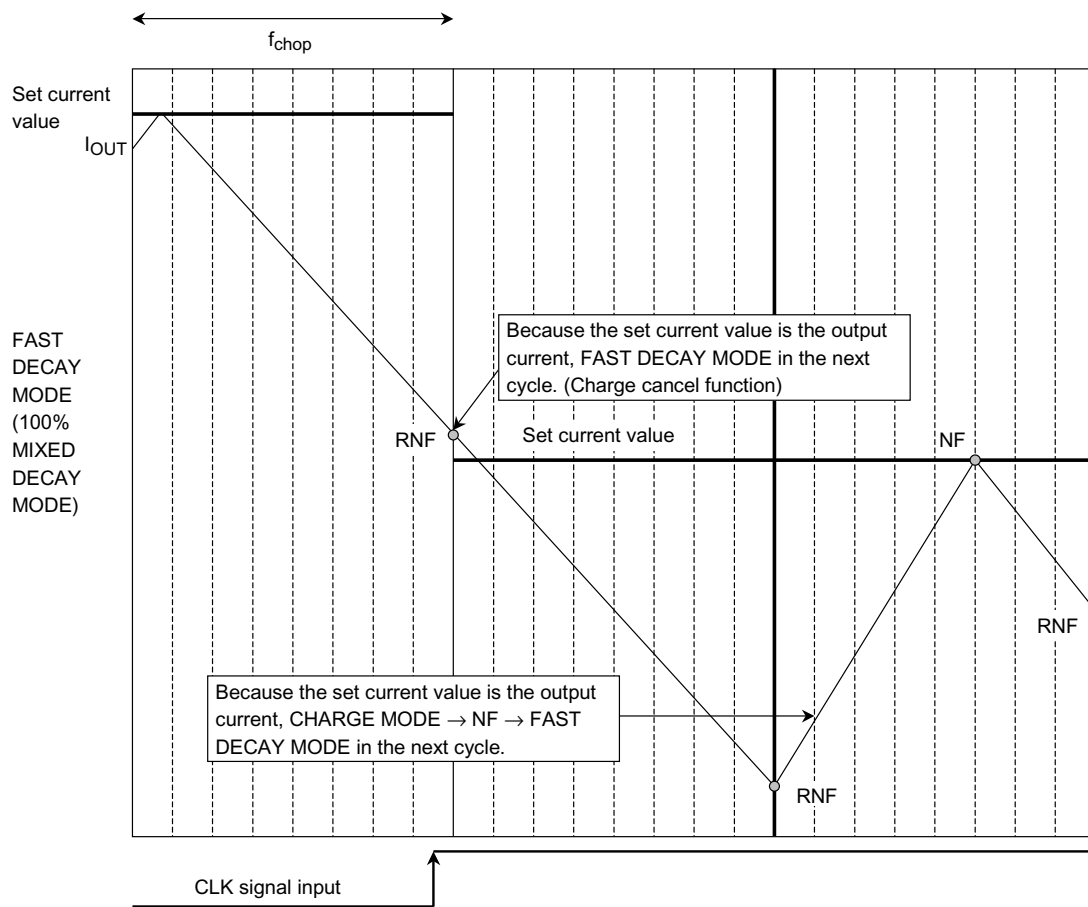

The output current to the motor is in supply voltage mode after the current value set by  $V_{ref}$ ,  $R_{RS}$ , or Torque reached at the set current value.



5. CLK SIGNAL, INTERNAL CR CLK, AND OUTPUT CURRENT waveform (When CLK signal is input in SLOW DECAY MODE)

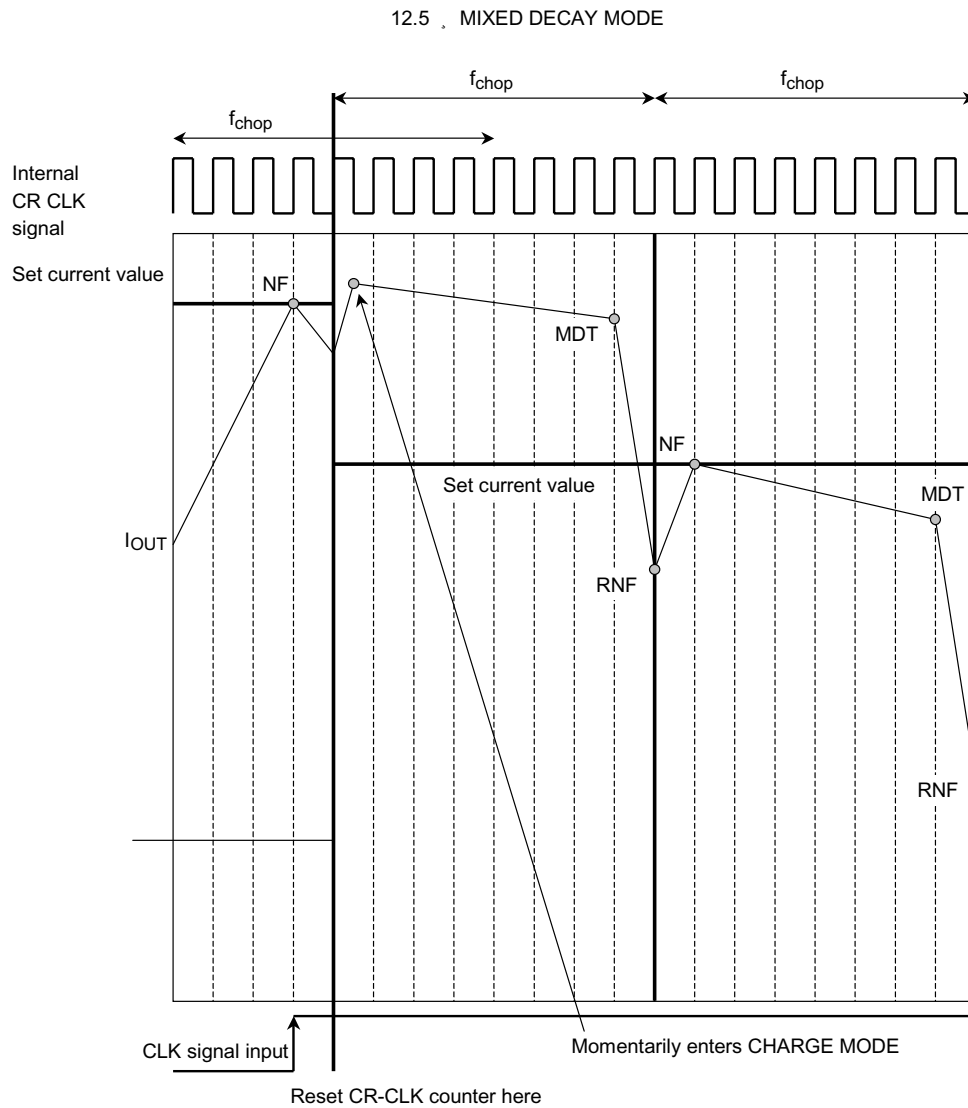

When CLK signal is input, the chopping counter (CR-CLK counter) is forced to reset at the next CR-CLK timing.

Because of this, compared with a method in which the counter is not reset, response to the input data is faster.

The delay time, the theoretical value in the logic portion, is expected to be a one-cycle CR waveform: 5  $\mu$ s at 100 kHz CHOPPING.

When the CR counter is reset due to CLK signal input, CHARGE MODE is entered momentarily due to current comparison.

Note: In FAST DECAY MODE, too, CHARGE MODE is entered momentarily due to current comparison.

**6. STROBE SIGNAL, INTERNAL CR CLK, AND OUTPUT CURRENT waveform  
(When CLK signal is input in CHARGE MODE)**

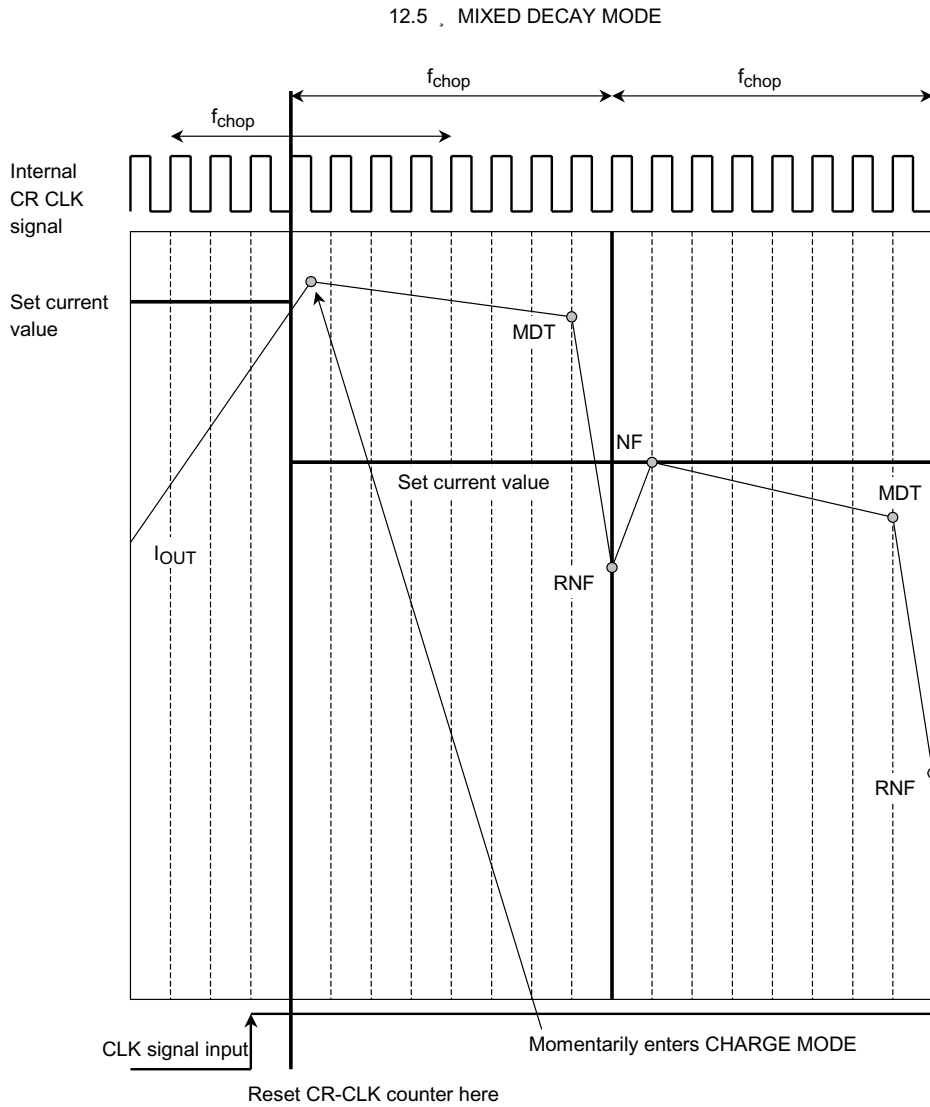

**7. STROBE SIGNAL, INTERNAL CR CLK, AND OUTPUT CURRENT waveform  
(When STROBE signal is input in FAST DECAY MODE)**

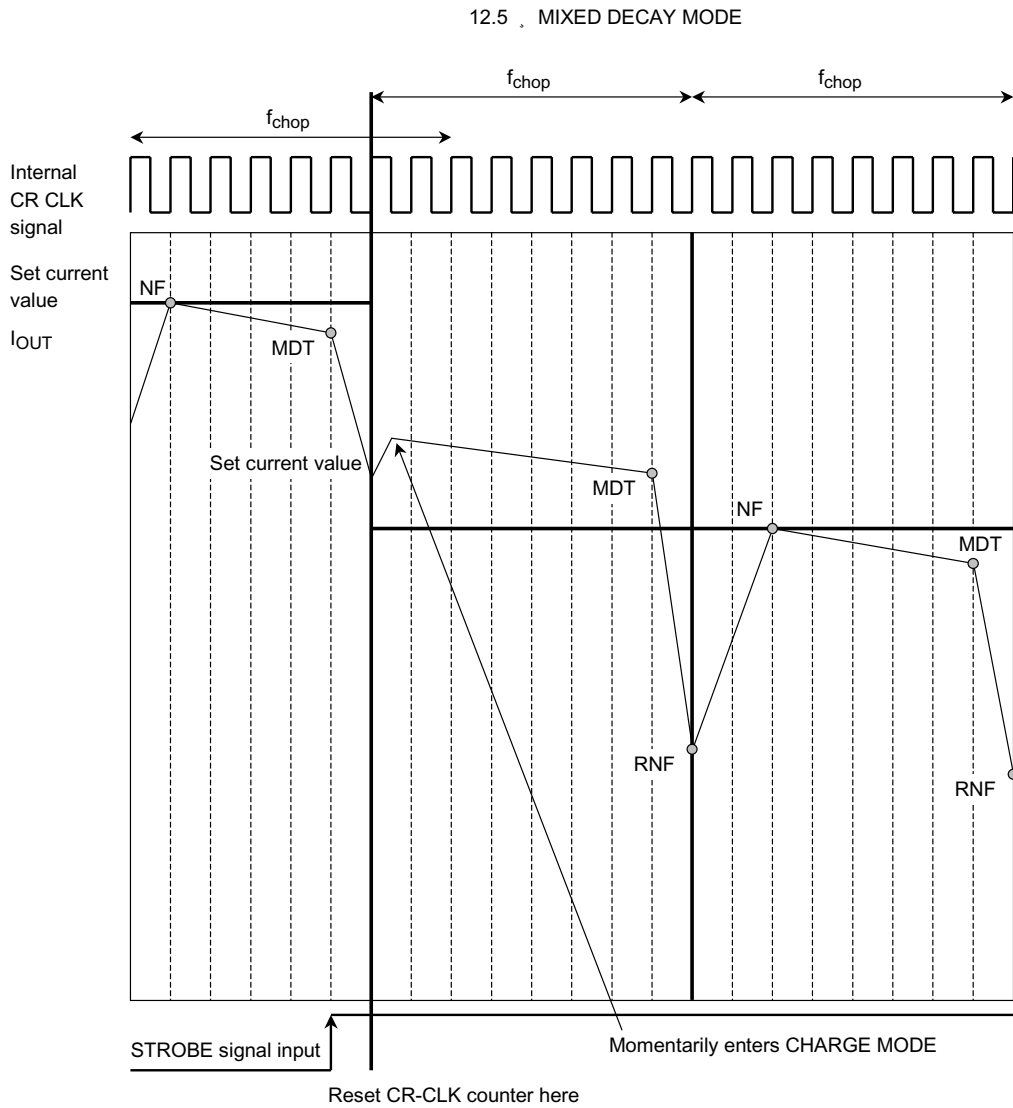

**8. CLK SIGNAL, INTERNAL CR CLK, AND OUTPUT CURRENT waveform  
(When CLK signal is input in 2 EXCITATION MODE)**

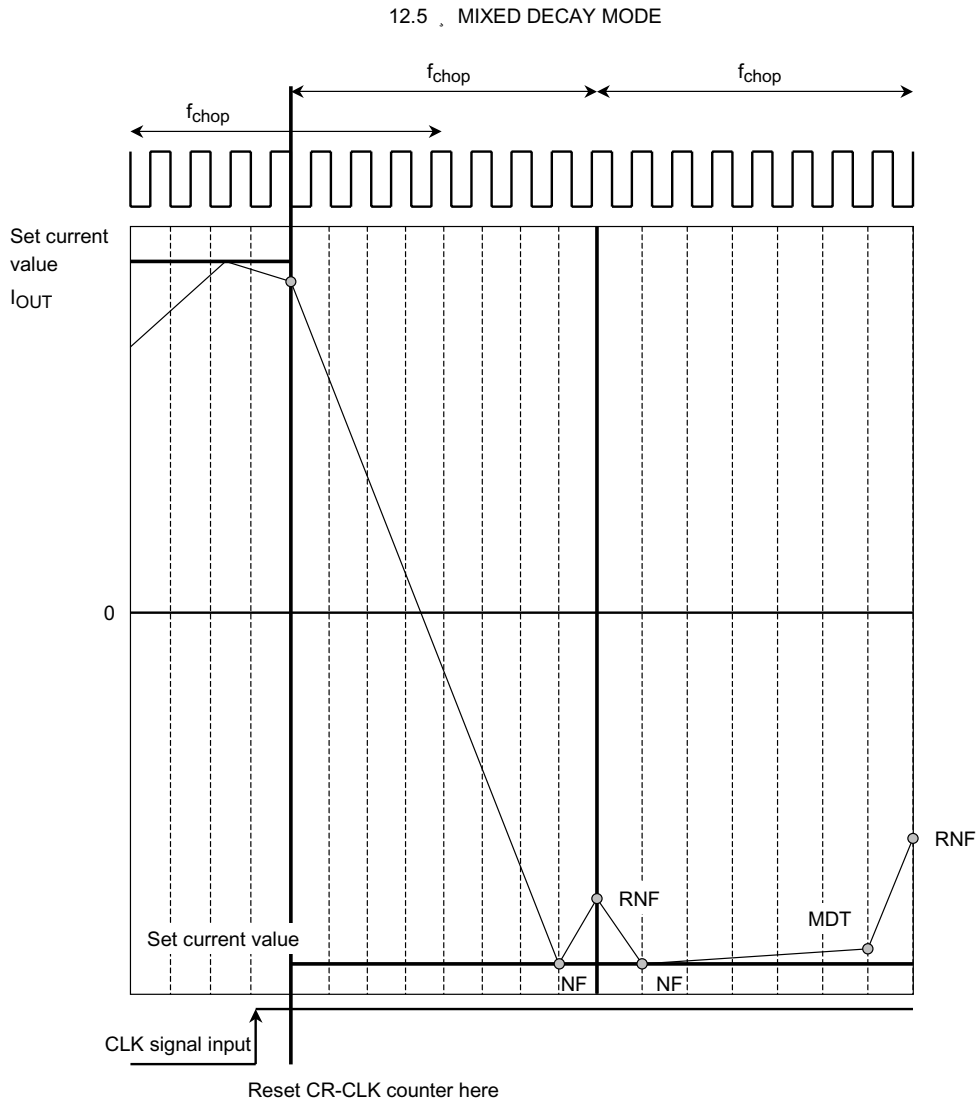

**Current Discharge Path when  $\overline{\text{ENABLE}}$  Input During Operation**

In Slow Mode, when all output transistors are forced to switch off, coil energy is discharged in the following MODES:

Note: Parasitic diodes are located on dotted lines. In normal MIXED DECAY MODE, the current does not flow to the parasitic diodes.

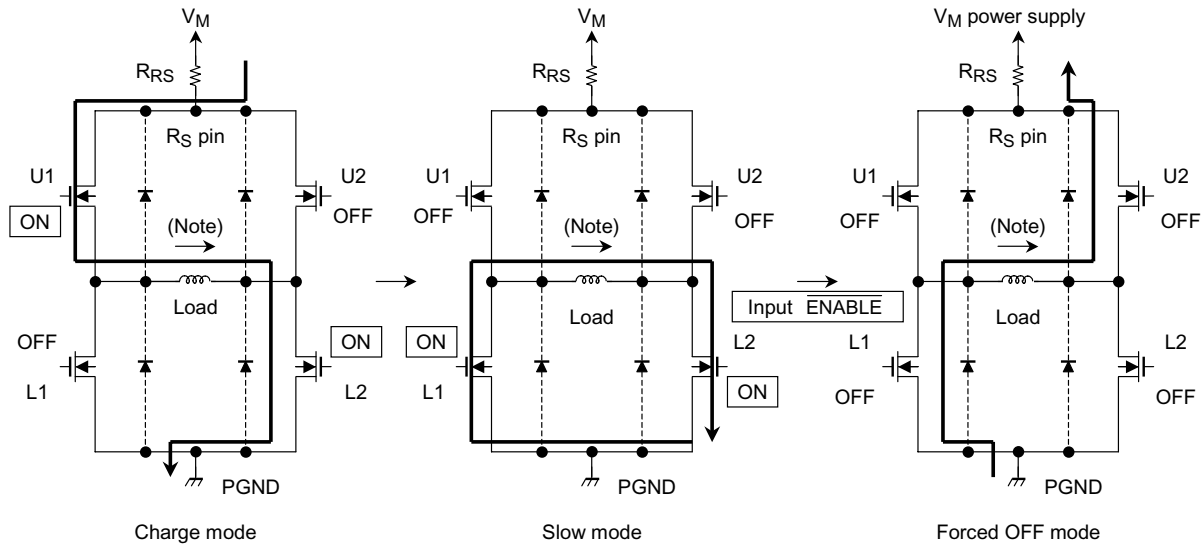

As shown in the figure at right, an output transistor has parasitic diodes.

To discharge energy from the coil, each transistor is switched on allowing current to flow in the reverse direction to that in normal operation. As a result, the parasitic diodes are not used. If all the output transistors are forced to switch off, the energy of the coil is discharged via the parasitic diodes.

## Output Transistor Operating Mode

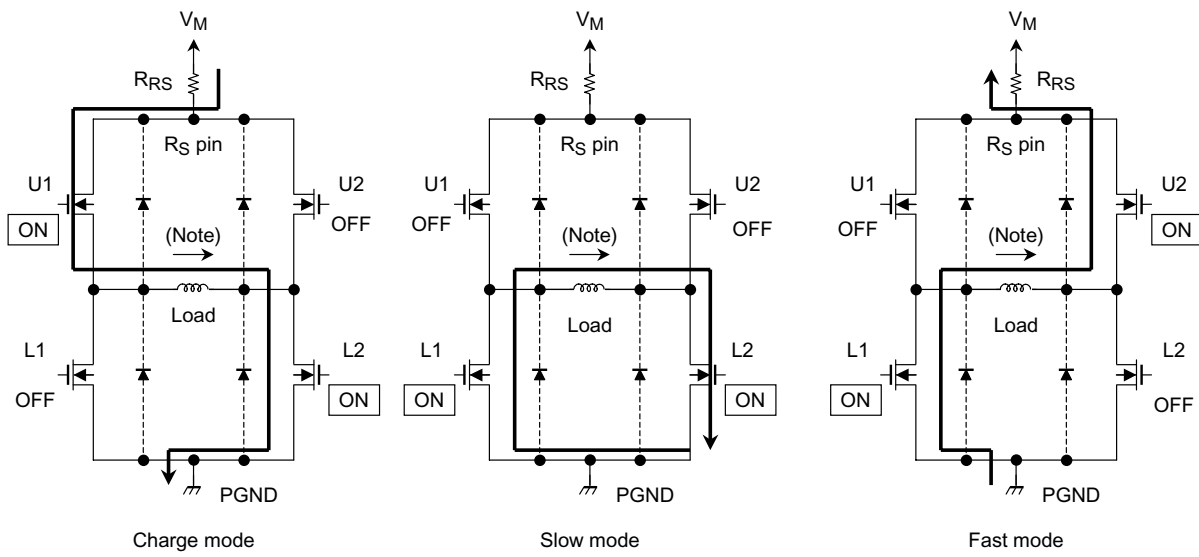

## Output Transistor Operation Functions

CLK	U1	U2	L1	L2
CHARGE	ON	OFF	OFF	ON
SLOW	OFF	OFF	ON	ON
FAST	OFF	ON	ON	OFF

Note: The above table is an example where current flows in the direction of the arrows in the above figures. When the current flows in the opposite direction of the arrows, see the table below.

CLK	U1	U2	L1	L2
CHARGE	OFF	ON	ON	OFF
SLOW	OFF	OFF	ON	ON
FAST	ON	OFF	OFF	ON

**Power Supply Sequence (Recommended)**

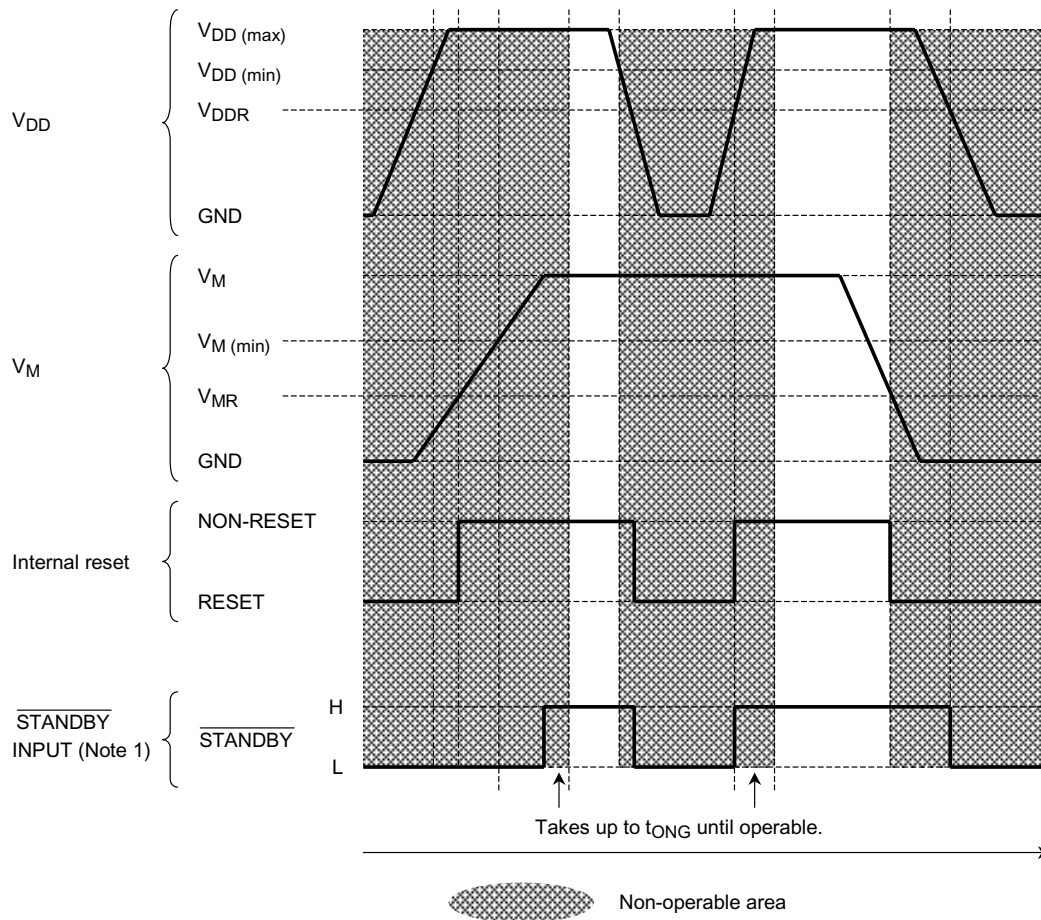

Note 1: If the V<sub>DD</sub> drops to the level of the V<sub>DDR</sub> or below while the specified voltage is input to the V<sub>M</sub> pin, the IC is internally reset.

This is a protective measure against malfunction. Likewise, if the V<sub>M</sub> drops to the level of the V<sub>MR</sub> or below while regulation voltage is input to the V<sub>DD</sub>, the IC is internally reset as a protective measure against malfunction.

To avoid malfunction, when turning on V<sub>M</sub> or V<sub>DD</sub>, to input the Standby signal at the above timing is recommended.

It takes time for the output control charge pump circuit to stabilize. Wait up to t<sub>ONG</sub> time after power on before driving the motors.

Note 2: When the V<sub>M</sub> value is between 3.3 to 5.5 V, the internal reset is released, thus output may be on. In such a case, the charge pump cannot drive stably because of insufficient voltage. The Standby state should be maintained until V<sub>M</sub> reaches 13 V or more.

Note 3: Since V<sub>DD</sub> = 0 V and V<sub>M</sub> = voltage within the rating are applied, output is turned off by internal reset. At that time, a current of several mA flows due to the Pass between V<sub>M</sub> and V<sub>DD</sub>. When voltage increases on V<sub>DD</sub> output, make sure that specified voltage is input.

**How to Calculate Set Current**

This IC controls constant current in CLK-IN mode.

At that time, the maximum current value (set current value) can be determined by setting the sensing resistor (R<sub>RS</sub>) and reference voltage (V<sub>ref</sub>).

$$I_{OUT(max)} = \frac{1}{5.0} \times V_{ref} (V) \times \frac{\text{Torque (Torque = 100, 85, 70, 50\%)}}{R_{RS}(\Omega)} \times 100$$

1/5.0 is V<sub>ref</sub> (gain): V<sub>ref</sub> attenuation ratio. (For the specifications, see the electrical characteristics.)

For example, when inputting V<sub>ref</sub> = 3 V and torque = 100% to output I<sub>OUT</sub> = 0.8 A, R<sub>RS</sub> = 0.75 Ω (0.5 W or more) is required.

**How to Calculate the Chopping and OSC Frequencies**

At constant current control, this IC chops frequency using the oscillation waveform (saw tooth waveform) determined by external capacitor and resistor as a reference.

The TB62209F requires an oscillation frequency of eight times the chopping frequency.

The oscillation frequency is calculated as follows:

$$f_{CR} = \frac{1}{0.523 \times (C \times R + 600 \times C)}$$

For example, when C<sub>osc</sub> = 560 pF and R<sub>osc</sub> = 3.6 kΩ are connected, f<sub>CR</sub> = 813 kHz.

At this time, the chopping frequency f<sub>chop</sub> is calculated as follows:

$$f_{chop} = f_{CR}/8 = 101 \text{ kHz}$$

When determining the chopping frequency, make the setting taking the above into consideration.

**IC Power Dissipation**

IC power dissipation is classified into two: power consumed by transistors in the output block and power consumed by the logic block and the charge pump circuit.

- Power consumed by the Power Transistor (calculated with R<sub>ON</sub> = 0.60 Ω)

In Charge mode, Fast Decay mode, or Slow Decay mode, power is consumed by the upper and lower transistors of the H bridges.

The following expression expresses the power consumed by the transistors of a H bridge.

$$P(\text{out}) = 2 (T_r) \times I_{OUT} (A) \times V_{DS} (V) = 2 \times I_{OUT}^2 \times R_{ON} \dots \dots \dots (1)$$

The average power dissipation for output under 4-bit micro step operation (phase difference between phases A and B is 90°) is determined by expression (1).

Thus, power dissipation for output per unit is determined as follows (2) under the conditions below.

$$\begin{aligned} R_{ON} &= 0.60 \Omega \text{ (at 1.0 A)} \\ I_{OUT} \text{ (Peak: max)} &= 1.0 \text{ A} \\ V_M &= 24 \text{ V} \\ V_{DD} &= 5 \text{ V} \\ P(\text{out}) &= 2 (T_r) \times 1.0^2 (A) \times 0.60 (\Omega) = 1.20 (W) \dots \dots \dots (2) \end{aligned}$$

Power consumed by the logic block and IM

The following standard values are used as power dissipation of the logic block and IM at operation.

$$\begin{aligned} I(\text{LOGIC}) &= 4.0 \text{ mA (typ.):} \\ I(\text{IM3}) &= 15.0 \text{ mA (typ.): operation/unit} \\ I(\text{IM1}) &= 4.0 \text{ mA (typ.): stop/unit} \end{aligned}$$

The logic block is connected to V<sub>DD</sub> (5 V). IM (total of current consumed by the circuits connected to V<sub>M</sub> and current consumed by output switching) is connected to V<sub>M</sub> (24 V). Power dissipation is calculated as follows:

$$P(\text{Logic\&IM}) = 5 (V) \times 0.004 (A) + 24 (V) \times 0.015 (A) = 0.38 (W) \dots \dots \dots (3)$$

Thus, the total power dissipation (P) is

$$P = P(\text{out}) + P(\text{Logic\&IM}) = 1.51 (W)$$

Power dissipation at standby is determined as follows:

$$P(\text{standby}) + P(\text{out}) = 24 (V) \times 0.004 (A) + 5 (V) \times 0.004 (A) = 0.116 (W)$$

For thermal design on the board, evaluate by mounting the IC.



Test Waveforms

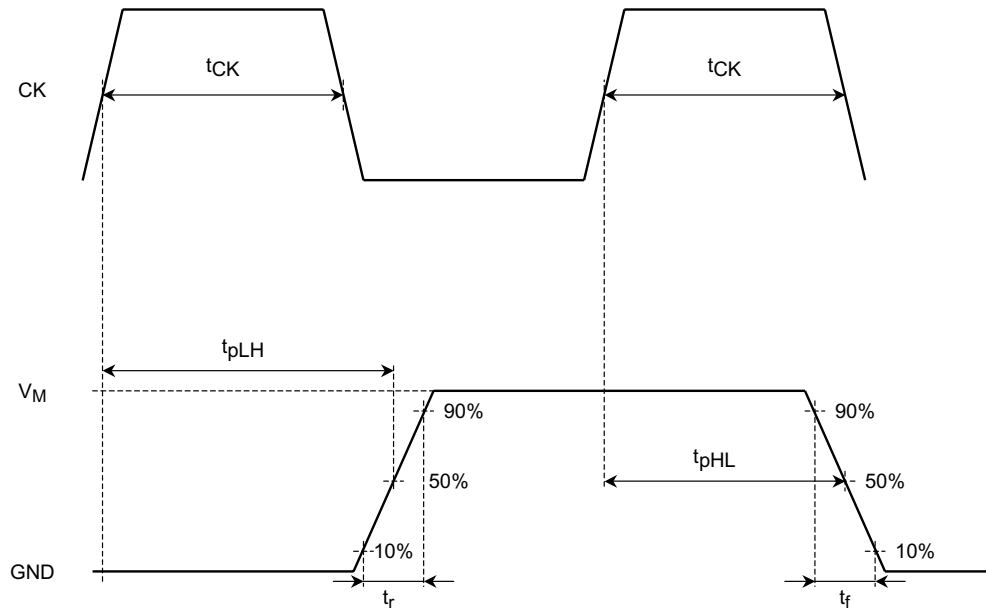
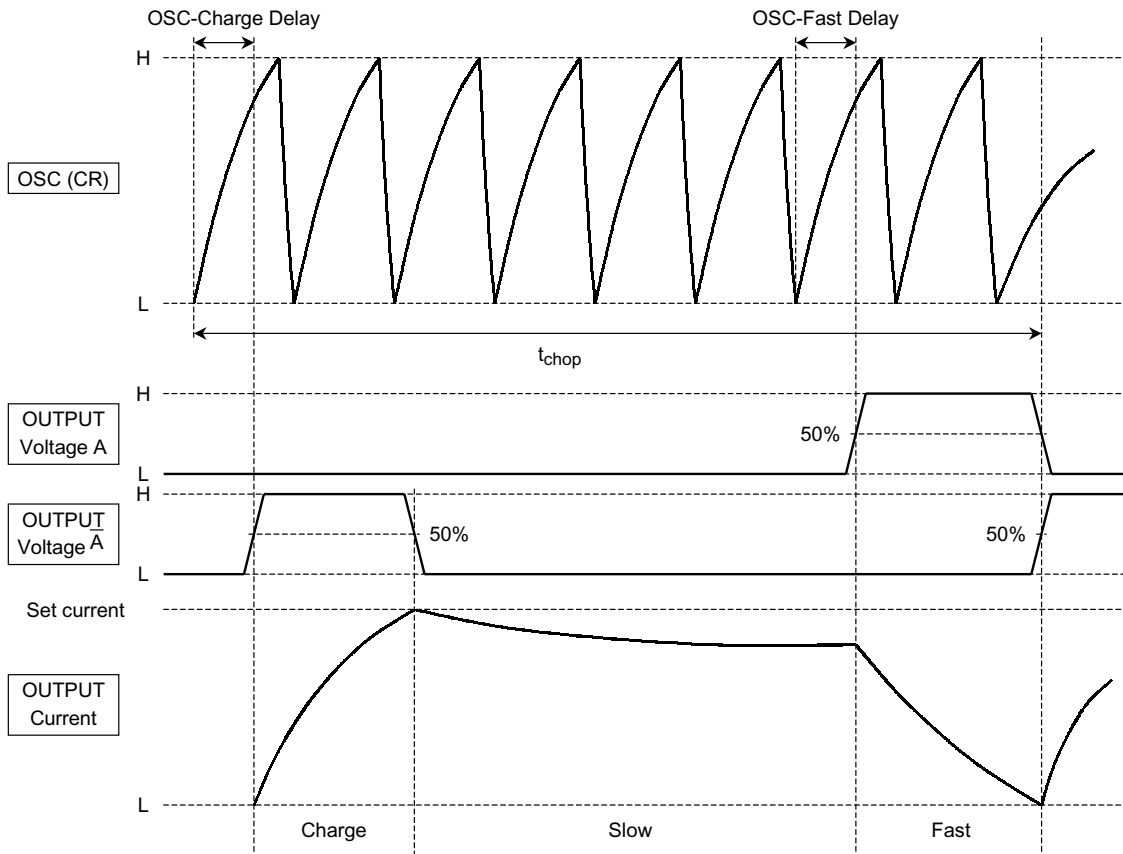

Figure 1 Timing Waveforms and Names



OSC-charge delay:

Because the rising edge level of the OSC waveform is used for converting the OSC waveform to the internal CR CLK, a delay of up to 1.25 ns (@ $f_{chop} = 100$  kHz:  $f_{CR} = 400$  kHz) occurs between the OSC waveform and the internal CR CLK.

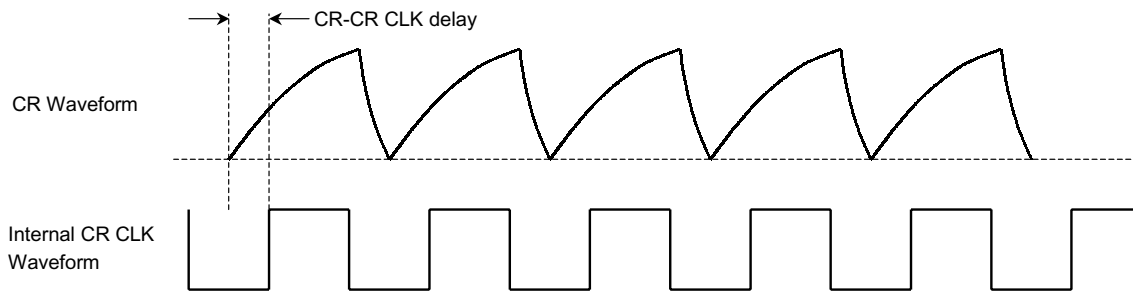
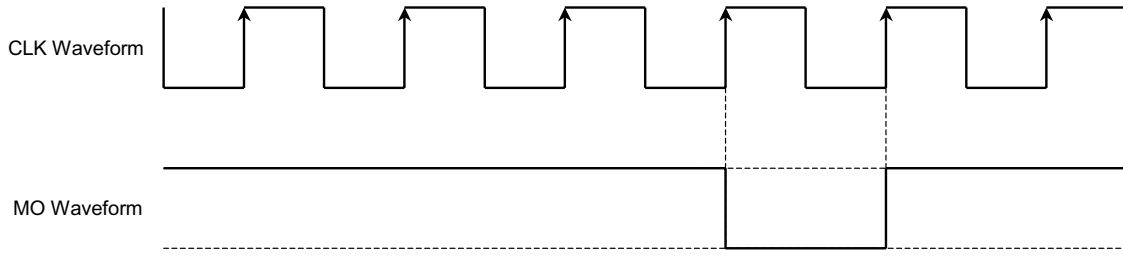
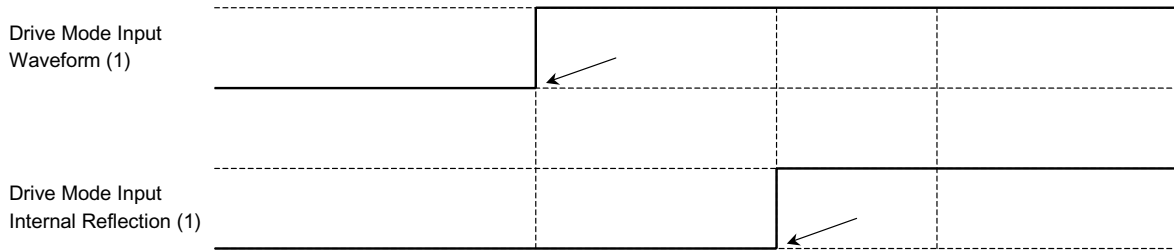

Figure 2 Timing Waveforms and Names (CR and output)

**Relationship between Drive Mode Input Timing and MO**



- If drive mode input changes before MO timing



Parallel set signal is reflected.

- If drive mode input changes after MO timing

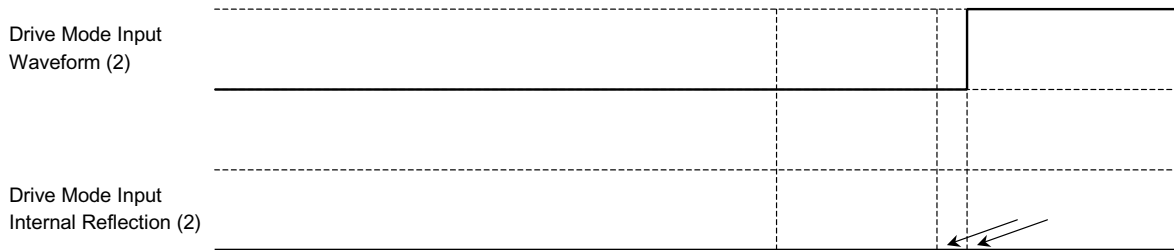

Parallel set signal occurs after the rising edge of CLK, therefore, it is not reflected. The drive mode is changed when the electrical angle becomes 0°.

Note: The TB62209F uses the drive mode change reserve method to prevent the motor from step out when changing drive modes.

Note that the following rules apply when switching drive modes at or near the MO signal output timing.

**Reflecting Points of Signals**

	Point where Drive Mode Setting Reflected	CW/CCW
2-Phase Excitation mode	45° (MO) Before half-clock of phase B = phase A = 100%	At rising edge of CLK input
1-2 Phase Excitation mode W1-2 Phase Excitation mode 2W1-2 Phase Excitation mode 4W1-2 Phase Excitation mode	0° (MO) Before half-clock of phase B = 100%	At rising edge of CLK input

Other parallel set signals can be changed at any time (they are reflected immediately).

**Recommended Point for Switching Drive Mode**

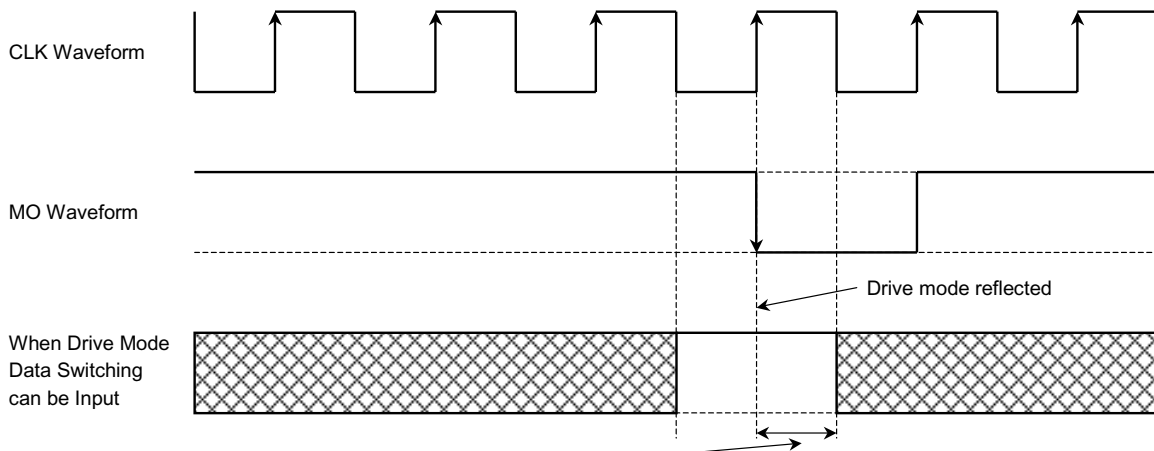

During MO output (phase data halted) to forcibly switch drive modes, a function to set  $\overline{\text{RESET}} = \text{Low}$  and to initialize the electrical angle is required.

**$P_D - T_a$  (Package power dissipation)**

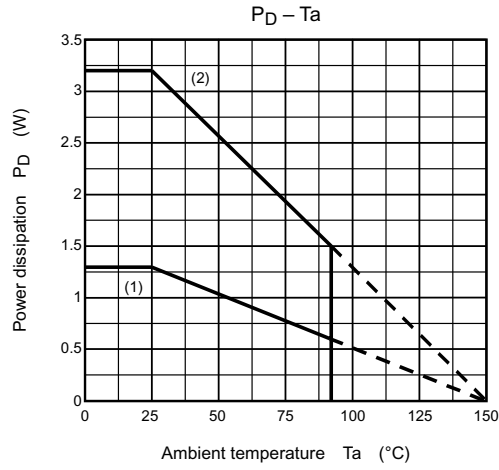

- (1) HSOP36  $R_{th(j-a)}$  only (96°C/W)
- (2) When mounted on the board (140 mm × 70 mm × 1.6 mm: 38°C/W: typ.)

Note:  $R_{th(j-a)}$ : 8.5°C/W

Relationship between  $V_M$  and  $V_H$  (charge pump voltage)

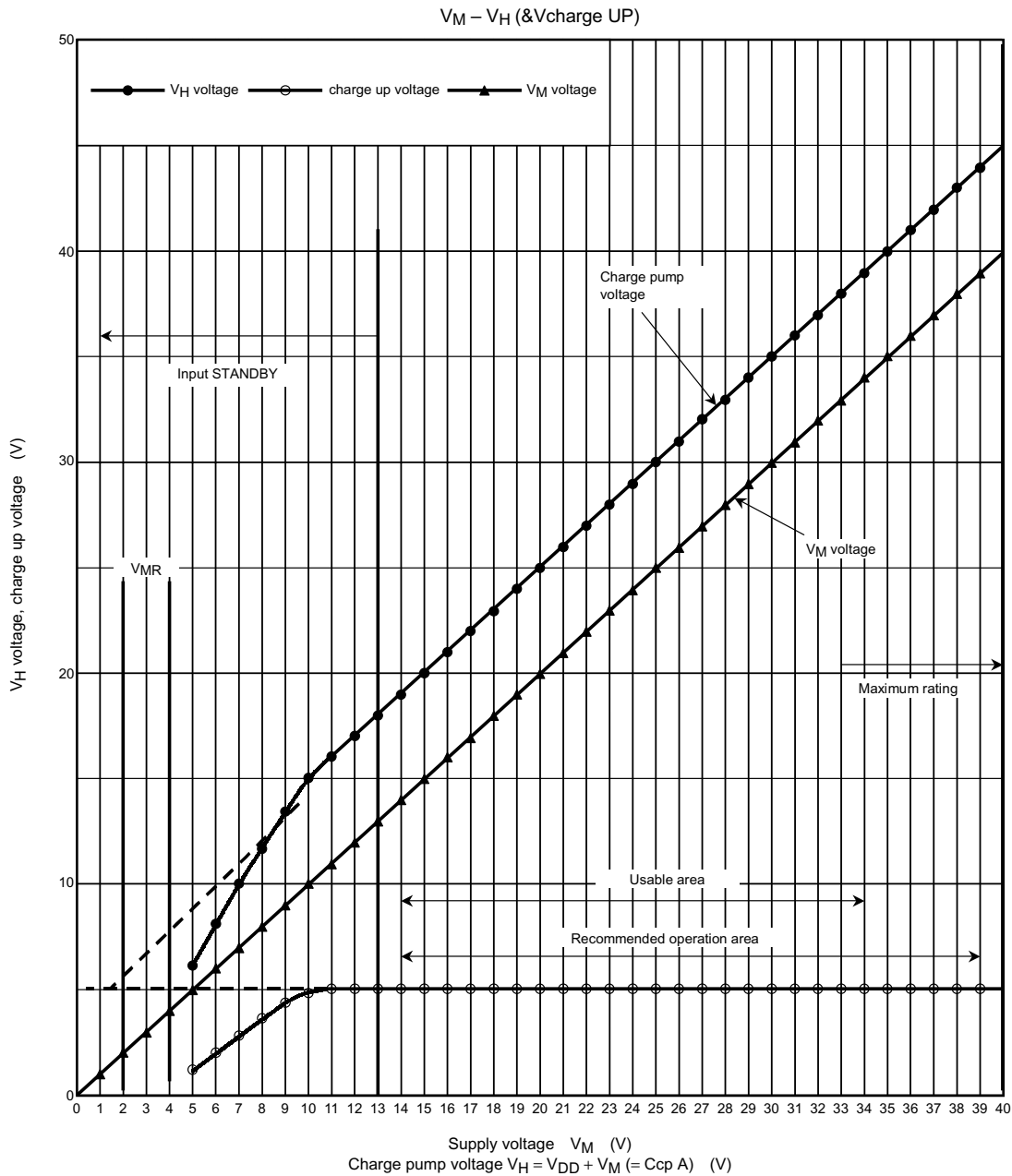

Note:  $V_{DD} = 5 V$   
 $C_{cp 1} = 0.22 \mu F$ ,  $C_{cp 2} = 0.022 \mu F$ ,  $f_{chop} = 150 \text{ kHz}$   
 (Be aware the temperature charges of charge pump capacitor.)

## Operation of Charge Pump Circuit

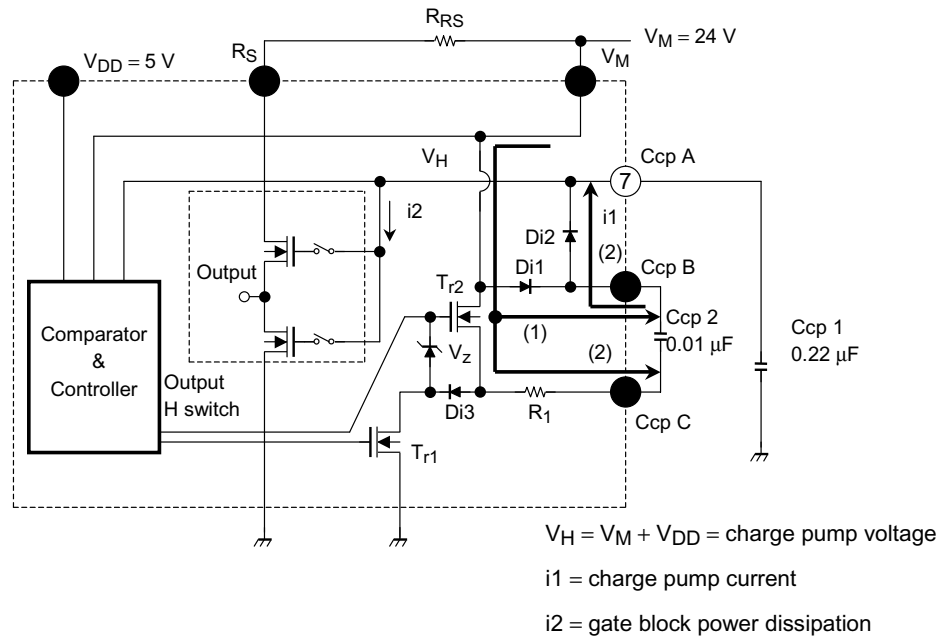

- Initial charging
  - (1) When RESET is released,  $T_{R1}$  is turned ON and  $T_{R2}$  turned OFF. Ccp 2 is charged from Ccp 2 via Di1.
  - (2)  $T_{R1}$  is turned OFF,  $T_{R2}$  is turned ON, and Ccp 1 is charged from Ccp 2 via Di2.
  - (3) When the voltage difference between  $V_M$  and  $V_H$  (Ccp A pin voltage = charge pump voltage) reaches  $V_{DD}$  or higher, operation halts (Steady state).
- Actual operation
  - (4) Ccp 1 charge is used at  $f_{chop}$  switching and the  $V_H$  potential drops.
  - (5) Charges up by (1) and (2) above.

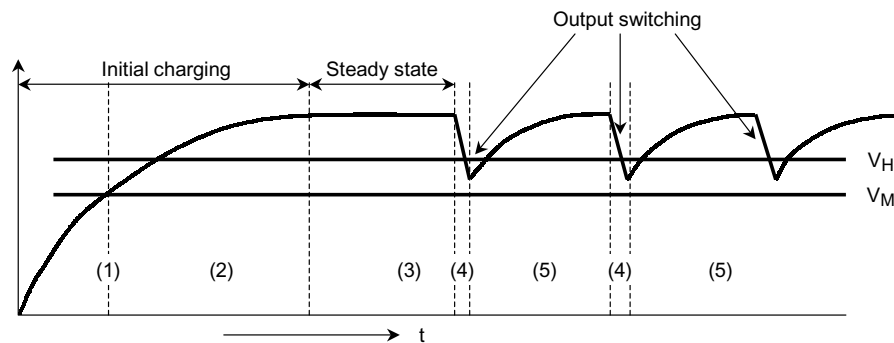

## Charge Pump Rise Time

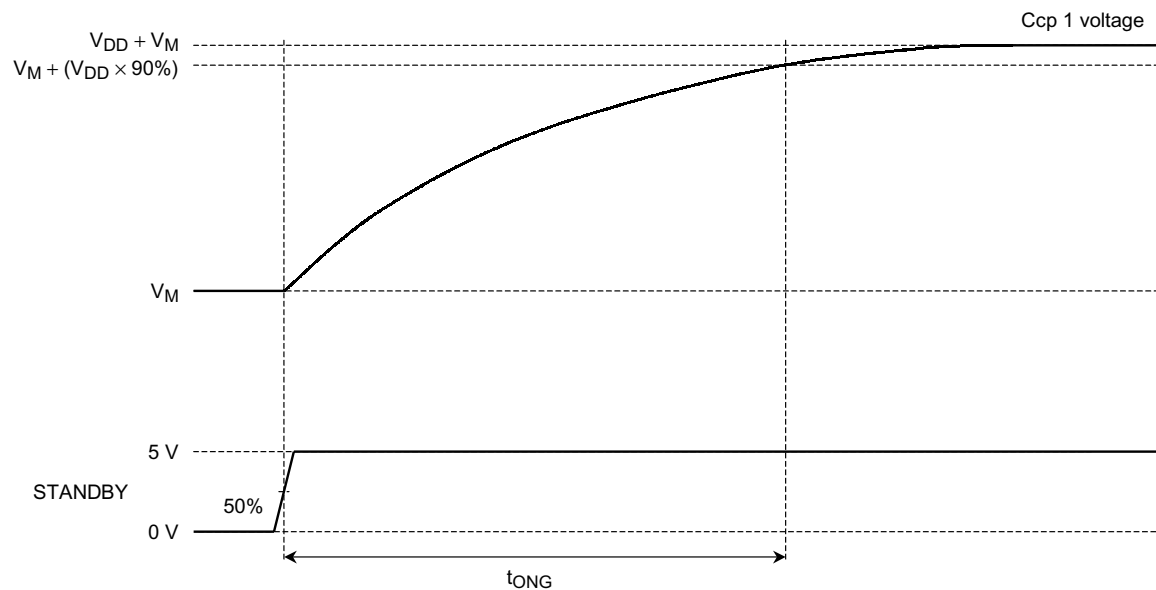
 **$t_{ONG}$ :**

Time taken for capacitor Ccp 2 (charging capacitor) to fill up Ccp 1 (storing capacitor) to  $V_M + V_{DD}$  after a reset is released.

The internal IC cannot drive the gates correctly until the voltage of Ccp 1 reaches  $V_M + V_{DD}$ . Be sure to wait for  $t_{ONG}$  or longer before driving the motors.

Basically, the larger the Ccp 1 capacitance, the smaller the voltage fluctuation, though the initial charge up time is longer.

The smaller the Ccp 1 capacitance, the shorter the initial charge-up time but the voltage fluctuation is larger.

Depending on the combination of capacitors (especially with small capacitance), voltage may not be sufficiently boosted. When the voltage does not increase sufficiently, output DMOS  $R_{ON}$  turns lower than the normal, and it raises the temperature.

Thus, use the capacitors under the capacitor combination conditions (Ccp 1 = 0.22  $\mu\text{F}$ , Ccp 2 = 0.02  $\mu\text{F}$ ) recommended by Toshiba.



**External Capacitor for Charge Pump**

When driving the stepping motor with  $V_{DD} = 5\text{ V}$ ,  $f_{chop} = 150\text{ kHz}$ ,  $L = 10\text{ mH}$  under the conditions of  $V_M = 13\text{ V}$  and  $1.5\text{ A}$ , the logical values for  $C_{cp1}$  and  $C_{cp2}$  are as shown in the graph below:

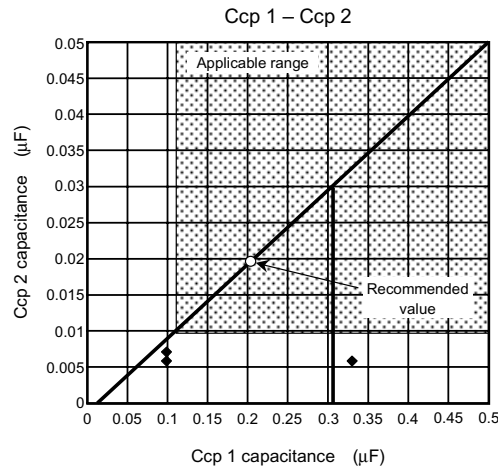

Choose  $C_{cp1}$  and  $C_{cp2}$  to be combined from the above applicable range. We recommend  $C_{cp1}:C_{cp2}$  at 10:1 or more. (If our recommended values ( $C_{cp1} = 0.22\text{ }\mu\text{F}$ ,  $C_{cp2} = 0.02\text{ }\mu\text{F}$ ) are used, the drive conditions in the specification sheet are satisfied. (There is no capacitor temperature characteristic as a condition.)

When setting the constants, make sure that the charge pump voltage is not below the specified value and set the constants with a margin (the larger  $C_{cp1}$  and  $C_{cp2}$ , the more the margin).

Some capacitors exhibit a large change in capacitance according to the temperature. Make sure the above capacitance is obtained under the usage environment temperature.

- (1) Low Power Dissipation mode  
 Low Power Dissipation mode turns off phases A and B, and also halts the charge pump.  
 Operation is the same as that when the STANDBY pin is set to Low.
- (2) Motor Lock mode  
 Motor Lock mode turns phase B output only off with phase A off.  
 From reset, with  $I_A = 0$  and  $I_B = 100\%$ , the normal 4W1-2 phase operating current is output.  
 Use this mode when you want to hold (lock) the rotor at any desired value.
- (3) 2-Phase Excitation mode

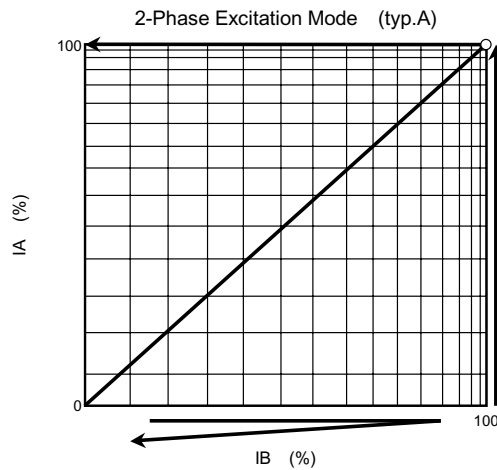
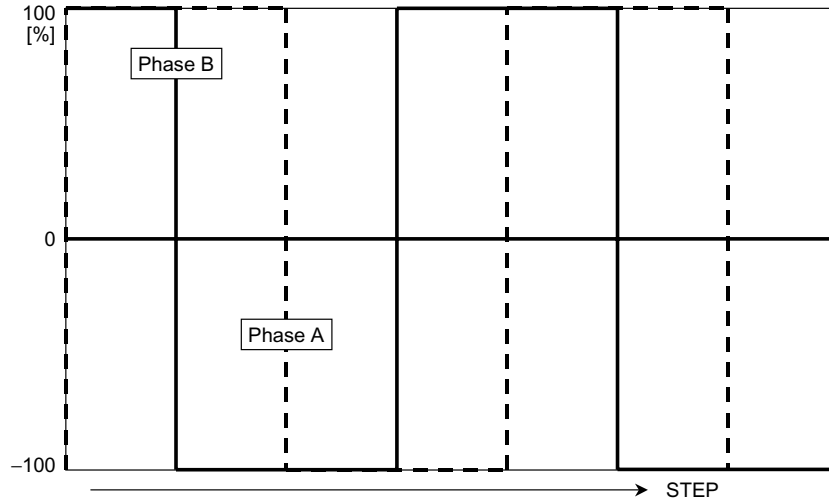

Electrical angle  $360^\circ = 4$  CLKs

Note: 2-phase excitation has a large load change due to motor induced electromotive force. If a mode in which the current attenuation capability (current control capability) is small is used, current increase due to induced electromotive force may not be suppressed. In such a case, use a mode in which the mixed decay ratio is large.

We recommend 37.5% Mixed Decay mode as the initial value (general condition).

(4) 1-2 Phase Excitation mode (a)

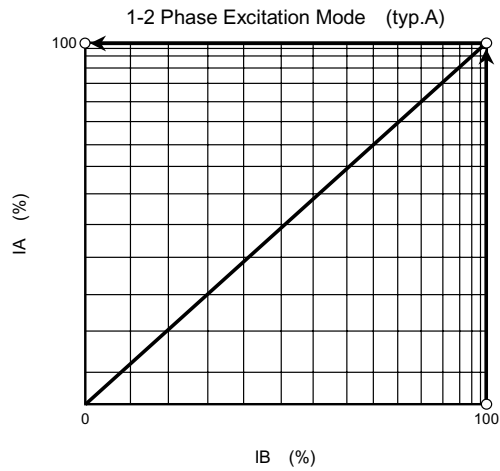
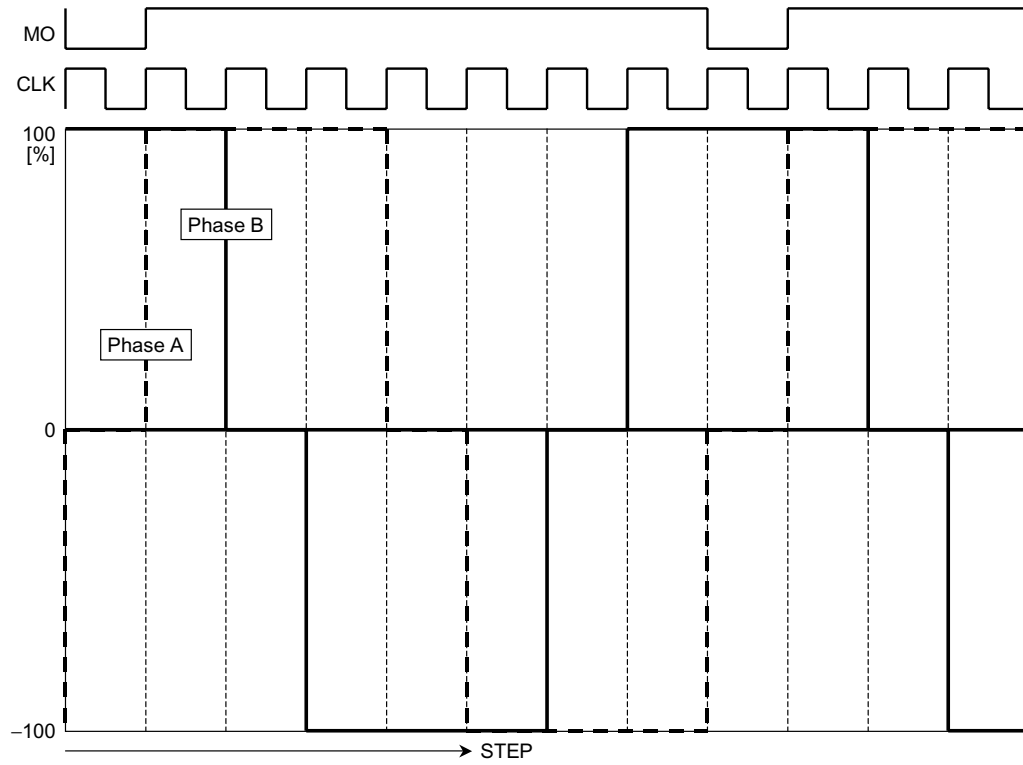

Electrical angle  $360^\circ = 8 \text{ CLKs}$

(5) 1-2 Phase Excitation mode (b)

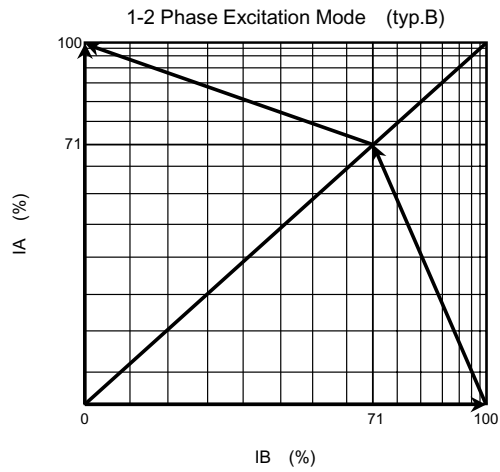
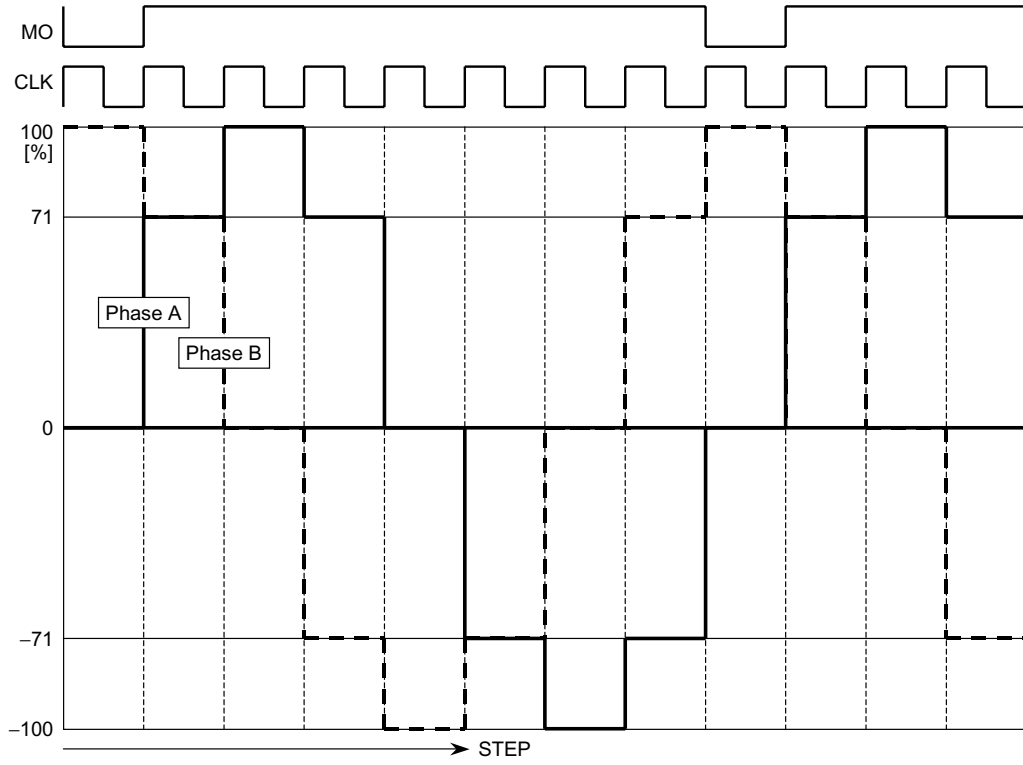

Electrical angle  $360^\circ = 8 \text{ CLKs}$

(6) W1-2 Phase Excitation mode

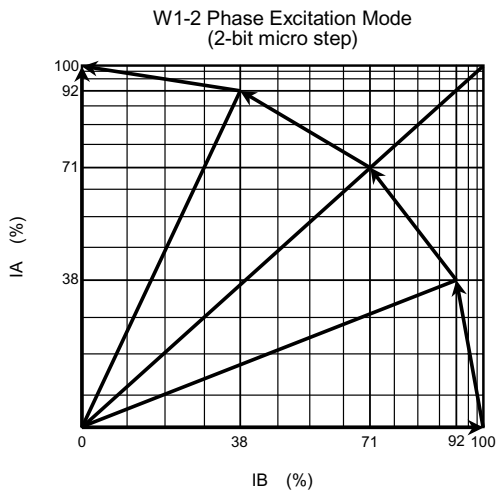
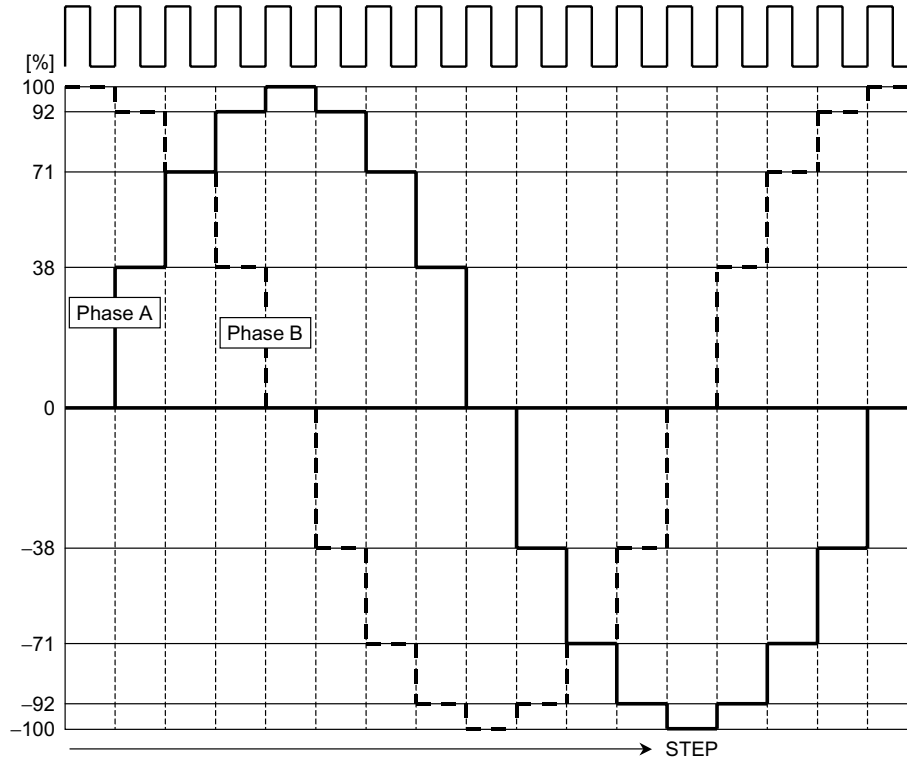

Electrical angle  $360^\circ = 16 \text{ CLKs}$

(7) 2W1-2 Phase Excitation mode

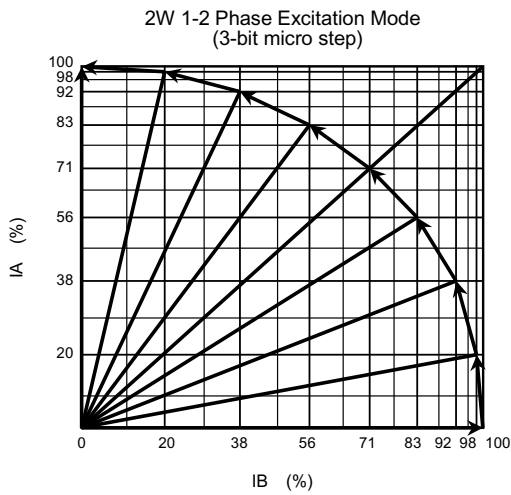
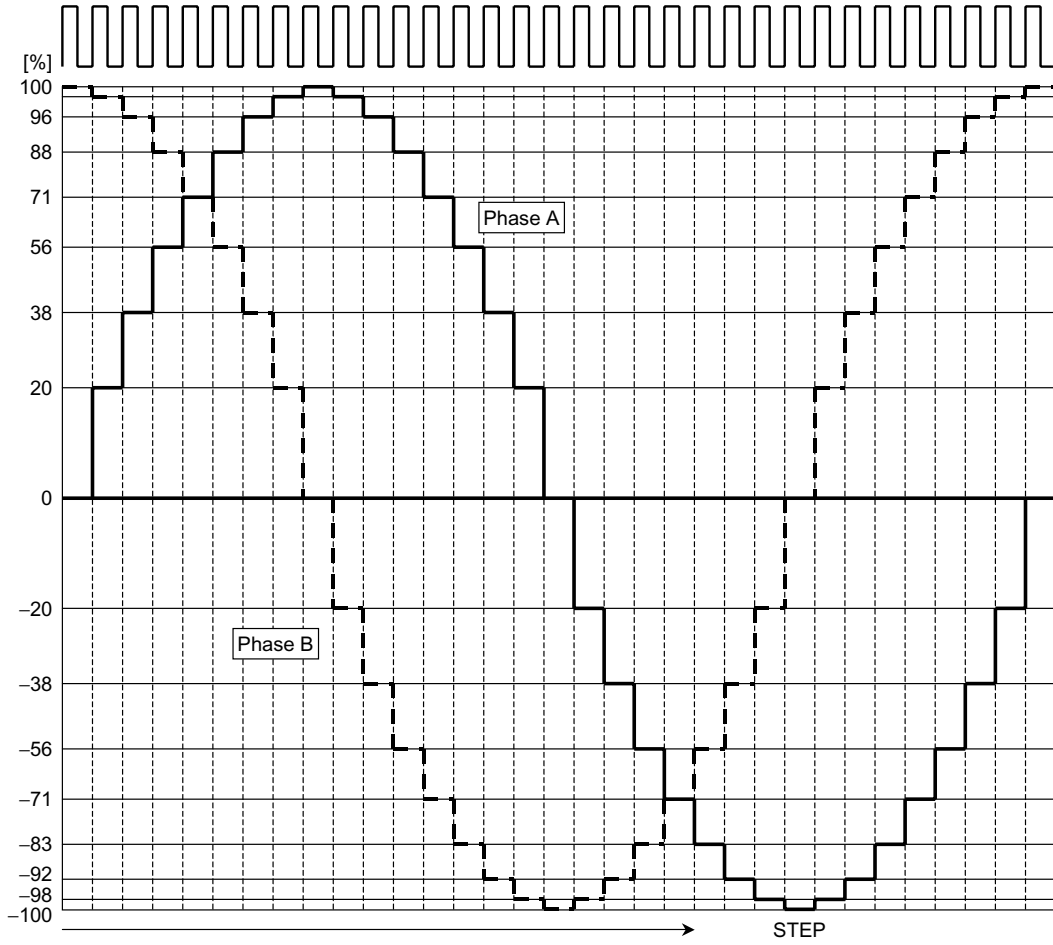

Electrical angle  $360^\circ = 32 \text{ CLKs}$

(8) 4W1-2 Phase Excitation mode

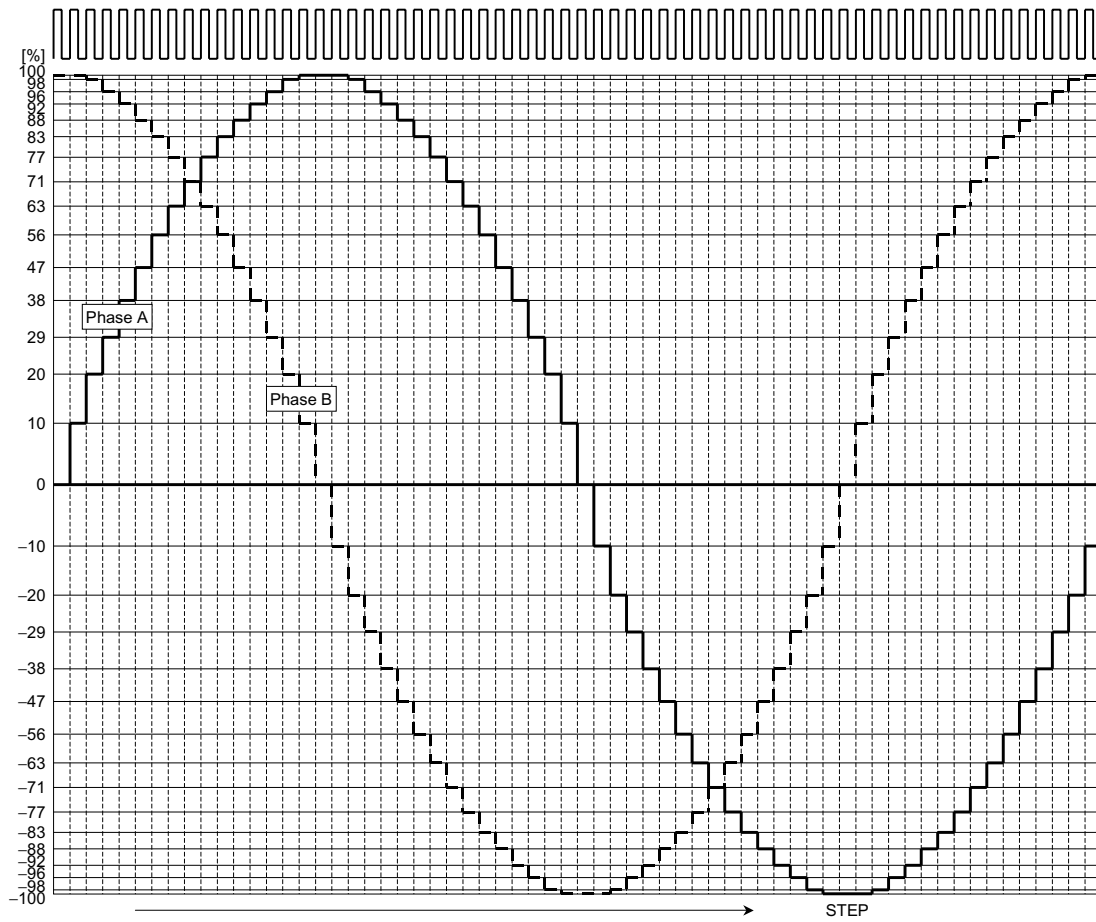

Electrical angle  $360^\circ = 64$  CLKs

4-Bit Micro Step Output Current Vector Locus (Normalizing each step to 90°)

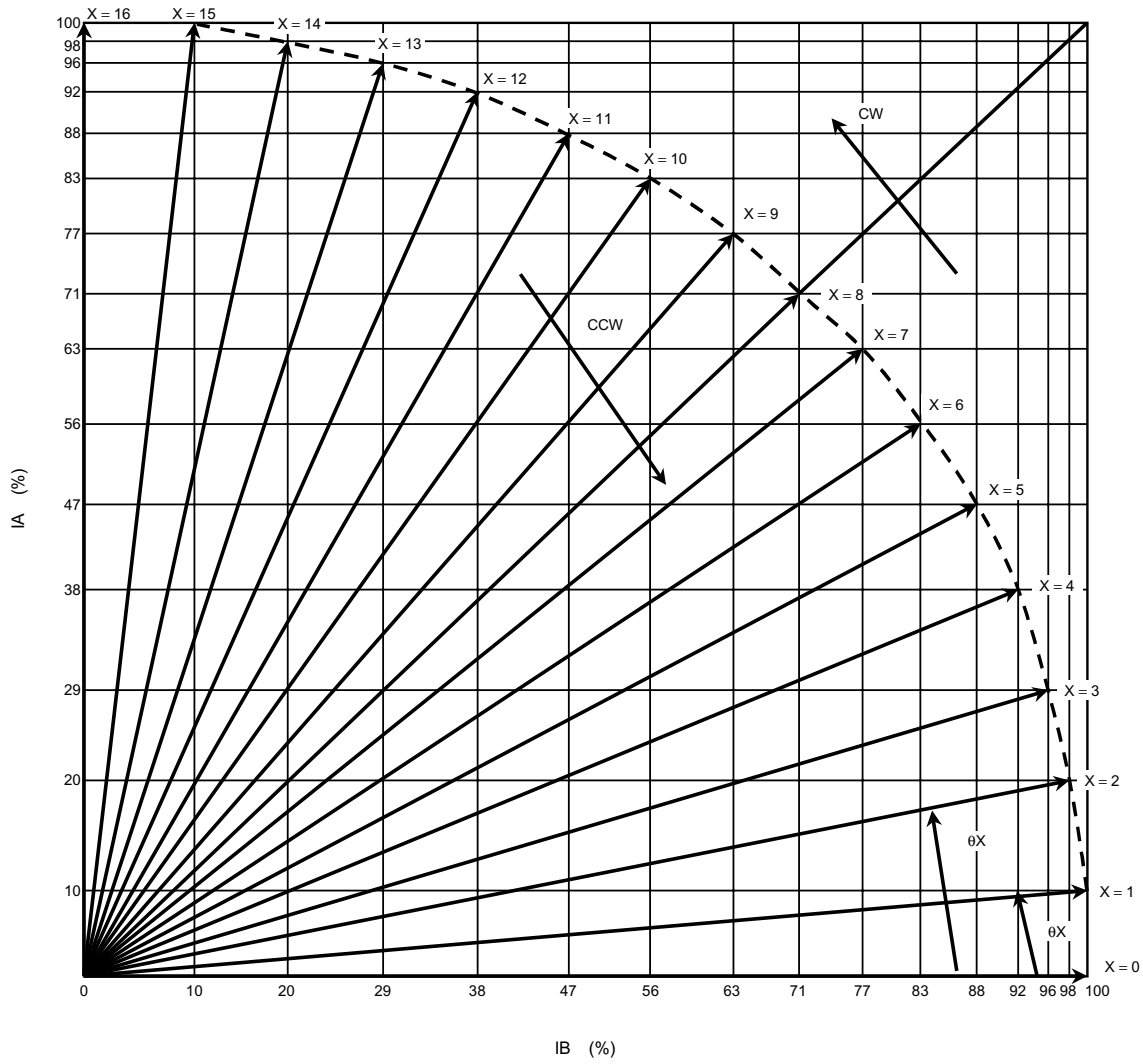

For input data, see the current function examples.



Recommended Application Circuit

The values for the devices are all recommended values. For values under each input condition, see the above-mentioned recommended operating conditions.

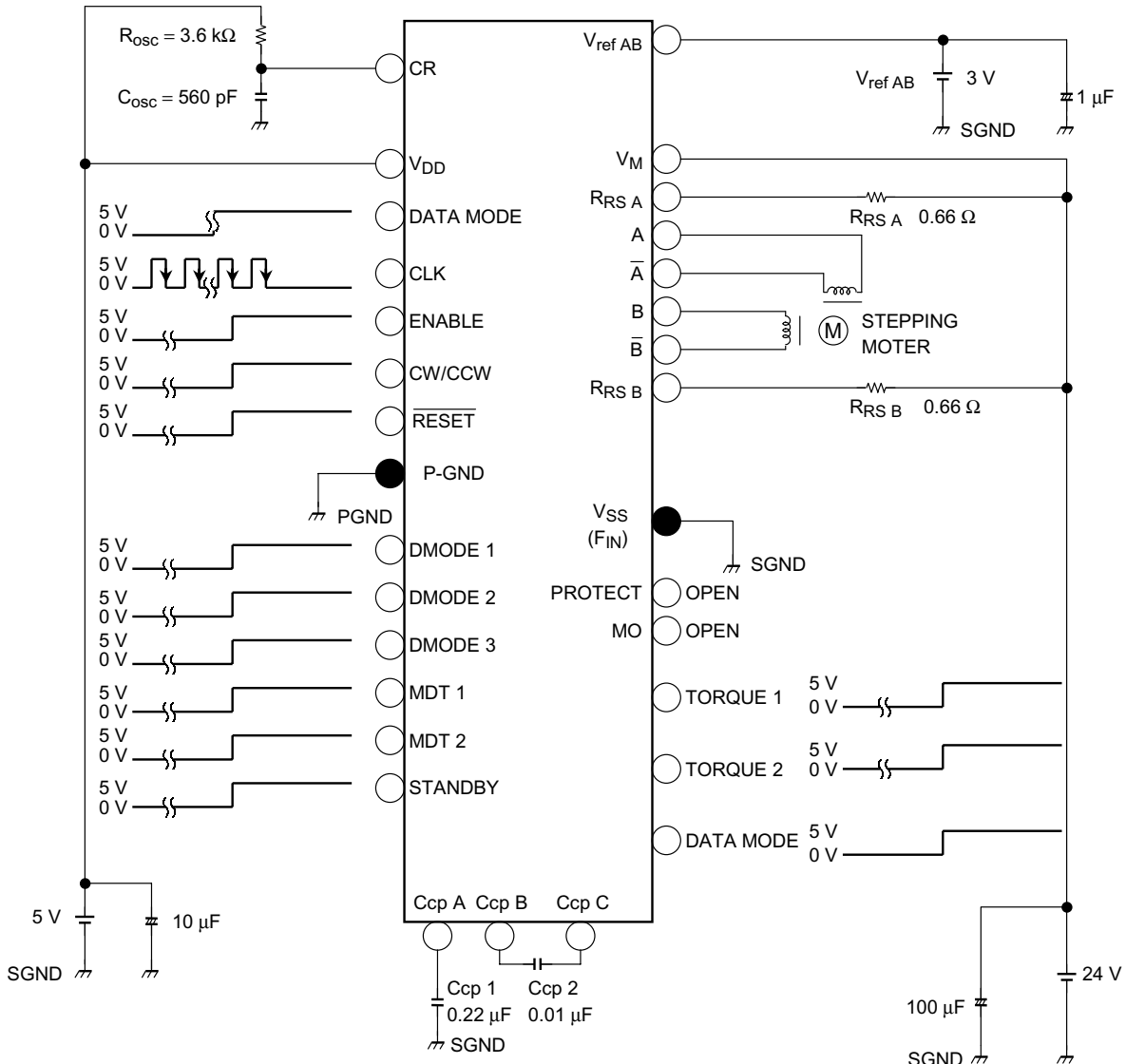

Note: Adding bypass capacitors is recommended.  
 Make sure that GND wiring has only one contact point, and to design the pattern that allows the heat radiation.  
 To control setting pins in each mode by SW, make sure to pull down or pull up them to avoid high impedance.  
 To input the data, see the section on the recommended input data.

Because there may be shorts between outputs, shorts to supply, or shorts to ground, be careful when designing output lines, VDD (VM) lines, and GND lines.

**Package Dimensions**

HSOP36-P-450-0.65

Unit: mm

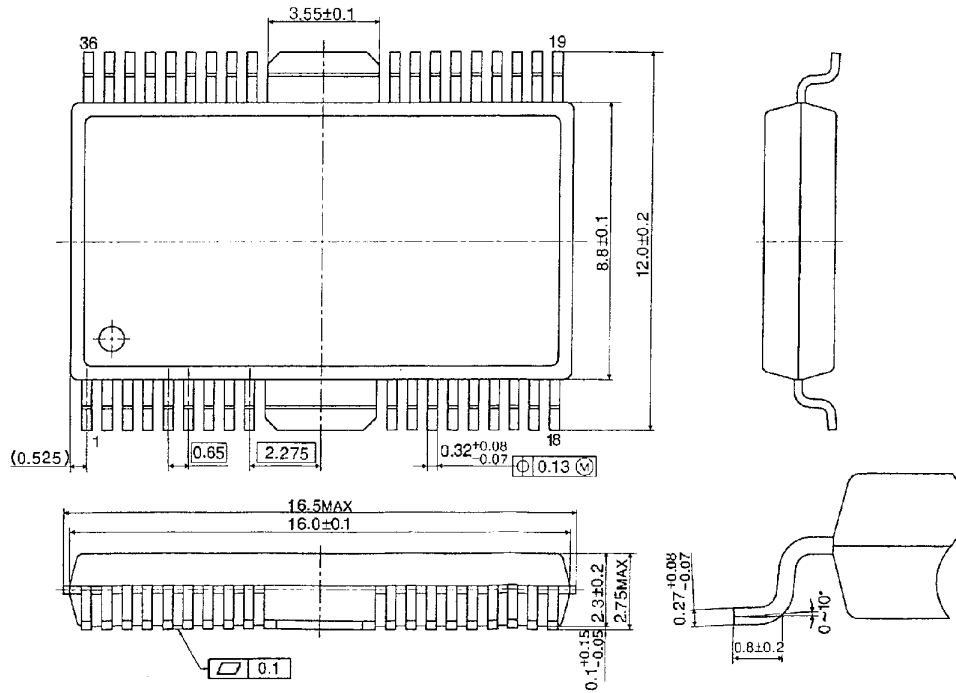

Weight: g (typ.)

**RESTRICTIONS ON PRODUCT USE**

000707EBA

- TOSHIBA is continually working to improve the quality and reliability of its products. Nevertheless, semiconductor devices in general can malfunction or fail due to their inherent electrical sensitivity and vulnerability to physical stress. It is the responsibility of the buyer, when utilizing TOSHIBA products, to comply with the standards of safety in making a safe design for the entire system, and to avoid situations in which a malfunction or failure of such TOSHIBA products could cause loss of human life, bodily injury or damage to property.  
In developing your designs, please ensure that TOSHIBA products are used within specified operating ranges as set forth in the most recent TOSHIBA products specifications. Also, please keep in mind the precautions and conditions set forth in the "Handling Guide for Semiconductor Devices," or "TOSHIBA Semiconductor Reliability Handbook" etc..
- The TOSHIBA products listed in this document are intended for usage in general electronics applications (computer, personal equipment, office equipment, measuring equipment, industrial robotics, domestic appliances, etc.). These TOSHIBA products are neither intended nor warranted for usage in equipment that requires extraordinarily high quality and/or reliability or a malfunction or failure of which may cause loss of human life or bodily injury ("Unintended Usage"). Unintended Usage include atomic energy control instruments, airplane or spaceship instruments, transportation instruments, traffic signal instruments, combustion control instruments, medical instruments, all types of safety devices, etc.. Unintended Usage of TOSHIBA products listed in this document shall be made at the customer's own risk.
- The products described in this document are subject to the foreign exchange and foreign trade laws.
- The information contained herein is presented only as a guide for the applications of our products. No responsibility is assumed by TOSHIBA CORPORATION for any infringements of intellectual property or other rights of the third parties which may result from its use. No license is granted by implication or otherwise under any intellectual property or other rights of TOSHIBA CORPORATION or others.
- The information contained herein is subject to change without notice.