

## White LED driver for mid-size LCD display backlight

Preliminary data

### Features

- Boost DC-DC converter
- Drives up to 40 LEDs (4 strings of 10) with a total current up to 120 mA
- Input voltage range: 3.0 V to 21 V
- Output current control
- 1.4 MHz fixed frequency PWM control
- PWM input for output current dimming with frequency range 25 kHz - 50 kHz
- 2 A integrated switch
- Overvoltage protection
- Chip overtemperature detection and protection
- Less than 1  $\mu$ A standby current
- Soft-start function
- Package DFN8 (3 x 3) 0.65 mm pitch

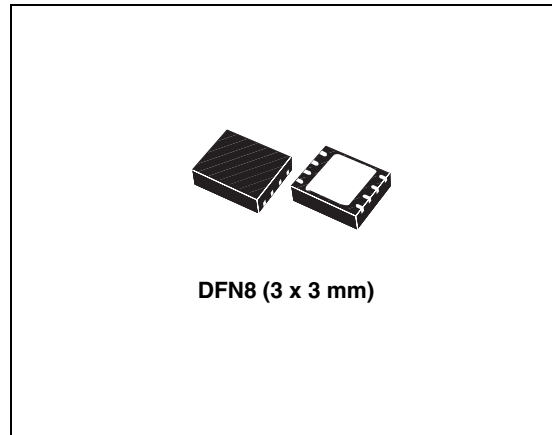

signal connected to the EN pin. The LEDs can be dimmed by applying a PWM signal to the PWM pin.

### Applications

- Mini PCs
- PMP & PND
- Printers
- Game consoles

### Description

The STLD41 is a boost converter that operates from 3.0 V to 21 V and can provide an output voltage as high as 38 V. It can drive up to 40 white LEDs connected in 4 strings of 10 LEDs in series. The total output current capability is 120 mA at an output voltage of 38 V. Regulation is performed by the internal error amplifier which works with the feedback voltage from the sensing resistor. The device can be turned ON/OFF by way of the logic

**Table 1. Device summary**

Order code	Package	Packaging
STLD41PUR	DFN8 (3 x 3 mm)	3000 parts per reel

# Contents

<b>1</b>	<b>Block diagram</b> .....	<b>3</b>
<b>2</b>	<b>Pin configuration</b> .....	<b>4</b>
<b>3</b>	<b>Maximum ratings</b> .....	<b>5</b>
<b>4</b>	<b>Typical application circuit</b> .....	<b>6</b>
<b>5</b>	<b>Electrical characteristics</b> .....	<b>7</b>
<b>6</b>	<b>Introduction</b> .....	<b>8</b>
	6.1 PWM input .....	8
<b>7</b>	<b>Selection of external components</b> .....	<b>9</b>
	7.1 $C_{IN}$ selection .....	9
	7.2 $C_{OUT}$ selection .....	9
	7.3 Inductor selection .....	9
	7.4 $R_{SENSE}$ value .....	10
	7.5 PCB layout .....	10
<b>8</b>	<b>Typical performance characteristics</b> .....	<b>13</b>
<b>9</b>	<b>Package mechanical data</b> .....	<b>14</b>
<b>10</b>	<b>Revision history</b> .....	<b>18</b>

# 1 Block diagram

Figure 1. STLD41 block diagram

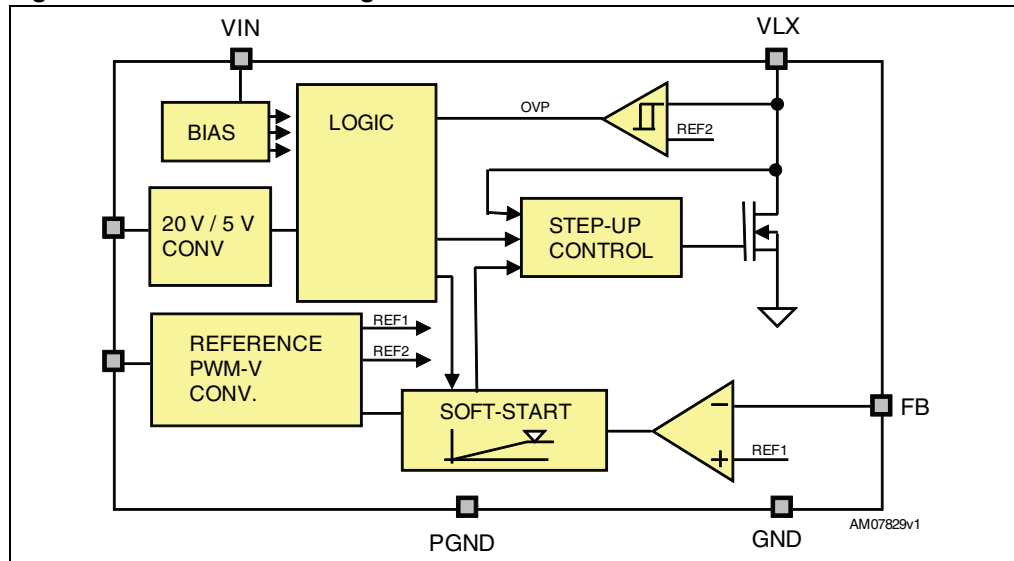

## 2 Pin configuration

Figure 2. Pin connections (top view)

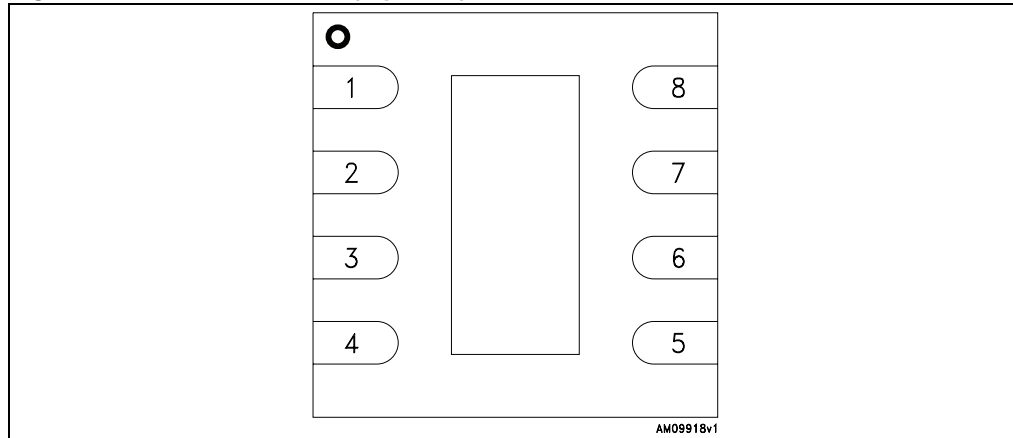

Table 2. Pin description

Pin n°	Symbol	Description
1	GND	Ground
2	FB	Feedback connection
3	GND	Analog ground
4	PGND	Power ground
5	VLX	Inductor connection
6	EN	Enable input
7	VIN	Supply voltage
8	PWM_IN	PWM input for the output current dimming
Exposed pad	PGND	Power ground

### 3 Maximum ratings

**Table 3. Absolute maximum ratings**

Symbol	Parameter	Value	Unit
V <sub>IN</sub>	Signal supply voltage	- 0.3 to 23	V
V <sub>LX</sub>	Inductor connection	- 0.3 to 40	V
FB	Feedback connection	- 0.3 to 2	V
EN	Logic pin	- 0.3 to 21	V
PWM_IN	PWM input	- 0.3 to 6	V
ESD	Human body model	± 2	kV
P <sub>TOT</sub>	Continuous power dissipation (at T <sub>A</sub> = 70 °C) <sup>(1)</sup>	TBD	mW
T <sub>OP</sub>	Operating ambient temperature range	- 40 to 85	°C
T <sub>J</sub>	Junction temperature	- 40 to 150	°C
T <sub>STG</sub>	Storage temperature range	- 65 to 150	°C

1. Power dissipation is dependent on the PCB. PCB design recommendations are included in [Section 7.5: PCB layout](#).

*Note: Absolute maximum ratings are those values beyond which damage to the device may occur. Functional operation under these conditions is not implied.*

**Table 4. Thermal data**

Symbol	Parameter	Value	Unit
R <sub>thJA</sub>	Thermal resistance junction-ambient	46	°C/W

## 4 Typical application circuit

Figure 3. Application circuit schematic

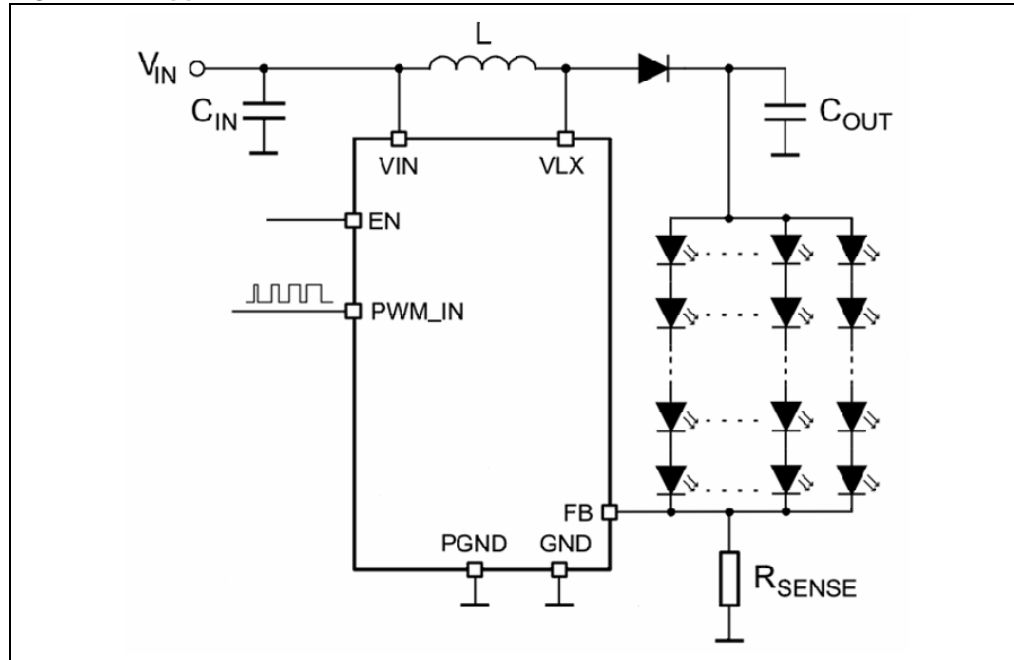

Table 5. List of external components

Component	Manufacturer	Part number	Value	Size
C <sub>IN</sub>	Murata	GRM32ER71H106K	10 μF / 50 V	3.2 x 2.5 x 2.5 mm
C <sub>OUT</sub>	Murata	GRM31CR61H225KA88L	2.2 μF / 50 V	3.2 x 1.6 x 1.6 mm
L	Murata	LQH6PPN470M43	47 μH / 1.25 A	6 x 6 x 4.3 mm
R <sub>SENSE</sub>	Tyco Electronics		1.3 Ω	0603 size
Schottky diode	STMicroelectronics	STPS1L40M	1 A / 40 V	3.75 x 1 x 1.9 mm
LED	OSRAM	LWL283-Q1R2-3K8L-1-Z	20 mA / 3.1 V	0603

Note: The above listed components refer to a typical application with a maximum performance setting. Operation of the STLD41 is not limited to the choice of these external components.

## 5 Electrical characteristics

$C_{IN} = 10 \mu\text{F}$ ,  $C_{OUT} = 2.2 \mu\text{F}$ ,  $L = 47 \mu\text{H} / 1.25 \text{ A}$ ,  $R_{SENSE} = 1.3 \Omega$ ,  $T_A = 25 \text{ }^\circ\text{C}$ ,  $V_{IN} = 5.5 \text{ V}$  typ.  
Values are at  $25 \text{ }^\circ\text{C}$ , unless otherwise specified.

**Table 6. Electrical characteristics**

Symbol	Parameter	Test conditions	Min.	Typ.	Max.	Unit
$V_{IN}$	Input operating supply voltage		3.0		21	V
$I_O$	Output current adjustment range	$V_{IN} = 3.0 \text{ V to } 5.0 \text{ V}$ ; $V_{OUT} = 38 \text{ V}$			40	mA
		$V_{IN} = 5.0 \text{ V to } 7.0 \text{ V}$ ; $V_{OUT} = 38 \text{ V}$			78	
		$V_{IN} = 7.0 \text{ V to } 18 \text{ V}$ ; $V_{OUT} = 38 \text{ V}$			120	
$V_{OUT}$	Regulated voltage range	$V_{IN} = 3.0 \text{ V to } 21 \text{ V}$	$1.15 \cdot V_{IN}$		38	V
$I_{PEAK}$	Inductor peak current	$V_{IN} = 3 \text{ V}$ , $V_{OUT} = 38 \text{ V}$		2		A
$\Delta I_O$	Output current variation	$V_{IN} = 3 \text{ V}$ , $I_{LED} = 120 \text{ mA}$	-10		10	%
$I_Q$	Quiescent current in Standby mode	EN = LOW, $V_{IN} = 5.5 \text{ V}$			1	$\mu\text{A}$
$V_{FB}$	Feedback voltage	$I_{LED} = 120 \text{ mA}$ , PWM_IN=HIGH	144	160	176	mV
$V_{FBMIN}$	Min. feedback voltage	PWM_IN = 30 kHz, duty cycle = 10%		35		mV
$f_s$	Frequency	$V_{IN} = 3.0 \text{ V}$		1.4		MHz
$\nu$	Efficiency of the chip itself <sup>(1)</sup>	$V_{IN} = 7 \text{ to } 21 \text{ V}$ , $I_O = 120 \text{ mA}$ , $V_O = 10 \times V_{FLED\_max} + V_{RSENSE} = 38 \text{ V}$		87		%
$\nu$	Efficiency of the whole application <sup>(2)</sup>	$V_{IN} = 3 \text{ to } 21 \text{ V}$ , $I_O = 78 \text{ mA}$		79		%
OVP	Output overvoltage protection	$V_{IN} = 21 \text{ V}$ , No load		40		V
OTP	Overtemperature protection	$V_{IN} = 21 \text{ V}$		140		$^\circ\text{C}$
OT <sub>HYST</sub>	Overtemperature hysteresis	$V_{IN} = 21 \text{ V}$		20		$^\circ\text{C}$
$V_{IL}$	Low and high level input logic signal on EN pin	$V_{IN} = 3.0 \text{ V to } 21 \text{ V}$	0		0.4	V
$V_{IH}$			1.4		$V_I$	
$I_{ENHIGH}$	Enable input current	$V_{IN} = 3.0 \text{ V to } 21 \text{ V}$ , $V_{EN} = 21 \text{ V}$		10		$\mu\text{A}$
$T_{ON}$	LED current rise time $I_{LED} = 0$ to $I_{LED} = \text{max}$	$V_{IN} = 10 \text{ V}$		1		ms
$f_{PWM}$	PWM dimming signal frequency	$V_{IN} = 3.0 \text{ V to } 21 \text{ V}$	25		50	kHz
$V_{PWM}$	PWM signal level	$V_{IN} = 3.0 \text{ V to } 21 \text{ V}$	1.4		5.5	V

1. Calculated as  $(V_{OUT} \cdot I_{LED}) / (V_{IN} \cdot I_{IN})$ , guaranteed by design

2. Calculated as  $(V_{LED} \cdot I_{LED}) / (V_{IN} \cdot I_{IN})$ , guaranteed by design

## 6 Introduction

The STLD41 is a boost converter, dedicated to power and control the current of white LEDs in an LCD backlight. The device operates at a typical constant switching frequency of 1.4 MHz. It steps an input voltage ranging from 3.0 V to 21 V up to 40 V. The output current is dimmable by the PWM signal applied to the PWM pin.

### 6.1 PWM input

The light intensity can be dimmed by a signal applied to the PWM input. It is recommended to use a signal whose frequency is between 25 kHz to 50 kHz. The maximum amplitude of the signal is limited to 5.5 V. The minimum level of the signal must be at least 1.4 V. The dimming range is from 20% to 100% of the current set by the  $R_{SENSE}$ .



## 7 Selection of external components

### 7.1 C<sub>IN</sub> selection

It is recommended to use 10 µF as the input capacitor to achieve good stability of the device and low noise on the V<sub>IN</sub> track.

### 7.2 C<sub>OUT</sub> selection

It is recommended to use 2.2 µF as the optimal value of output capacitor to achieve the best compromise between output voltage ripple and load transient response. The output ripple can be checked using the equation for step-up architecture:

#### Equation 1

$$V_{PK-PK} = \frac{I_{OUT(MAX)} \cdot V_{OUT} \cdot V_{IN(MIN)} \cdot 100}{C_{OUT} \cdot V_{OUT}^2 \cdot f} \quad V; A, V, F, Hz$$

### 7.3 Inductor selection

A thin shielded inductor with a low DC series winding resistance is recommended for this application. To achieve good efficiency in step-up mode, it is recommended to use an inductor with a DC series resistance  $R_{DCL} = R_D / 10$  [Ω, Ω, 1], where  $R_D$  is the dynamic resistance of the LED [Ω, Ω, 1].

For nominal operation, the peak inductor current can be calculated using this formula:

#### Equation 2

$$I_{PEAK} = \frac{I_{OUT}}{n} + \frac{V_{OUT} \cdot V_{IN} \cdot V_{IN}^2}{2 \cdot L \cdot f \cdot V_{OUT}^2} \cdot \frac{V_{OUT}}{V_{IN}}$$

where:

$I_{PEAK}$  = Peak inductor current

$I_{OUT}$  = Current sourced at the V<sub>OUT</sub> pin

$n$  = Efficiency of the STLD41

$V_{OUT}$  = Output voltage at the V<sub>OUT</sub> pin

$V_{IN}$  = Input voltage at the VBAT-pin

$L$  = Inductance value of the inductor

$f$  = Switching frequency

For optimal performance of the STLD41 device, it is recommended to use an inductor value of 47  $\mu\text{H}$  or higher with low serial resistance and relevant saturation current calculated from the equation above.

## 7.4 $R_{\text{SENSE}}$ value

$$R_{\text{SENSE}} = V_{\text{REF1}} / I_{\text{LED}}$$

If using a typical setting of  $I_{\text{LED}} = 120 \text{ mA}$ ,  $V_{\text{REF1}} = 160 \text{ mV}$ , and  $R_{\text{SENSE}} = 1.3 \Omega$ , the resistor must be rated for a power dissipation of  $1.3 \times 0.122 \text{ W} = 0.02 \text{ W}$ .

## 7.5 PCB layout

Because the STLD41 is a powerful switched device, the PCB must be designed in line with rules for designing switched supplies. It is recommended to use a two-layer PCB. The power wirings must be as short as possible and wide. Place all external components close to the STLD41 device. High-energy switched loops should be as small as possible to reduce EMI. Most LEDs need cooling, which can be attained utilizing a defined copper area on the PCB. Use the reference guide for each LED to design the heatsink. Place the  $R_{\text{SENSE}}$  resistor as close as possible to pin 2 and ground of the system. The ground of the system is represented by the size of the area created by the connections  $\text{GND-PGDN-GND}_{\text{CIN}}$ - $\text{GND}_{\text{COUT}}$ . When a change of PCB layer is needed, use sufficient vias. During routing, the PCB must be focused on the minimum area of the application ground; the smaller the ground area of the DC-DC converter<sup>(a)</sup>, the better the stability and there will be fewer noise issues. It is recommended to place the copper plate connected through the vias to the exposed pad to the bottom layer to create the heatsink of the device.

---

a. The application ground area is represented by the area which is created by the ground pins of the  $C_{\text{IN}}$ ,  $C_{\text{OUT}}$ , and ground of the DEVICE and GND connection of the load.

Figure 4. Top layer

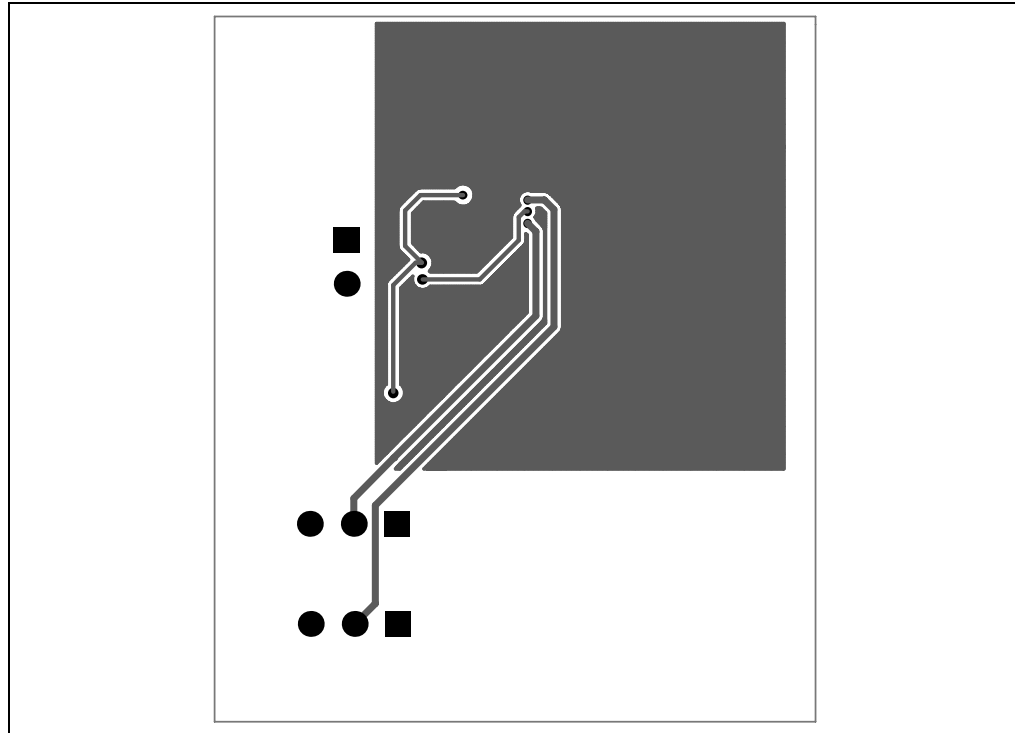

Figure 5. Bottom layer

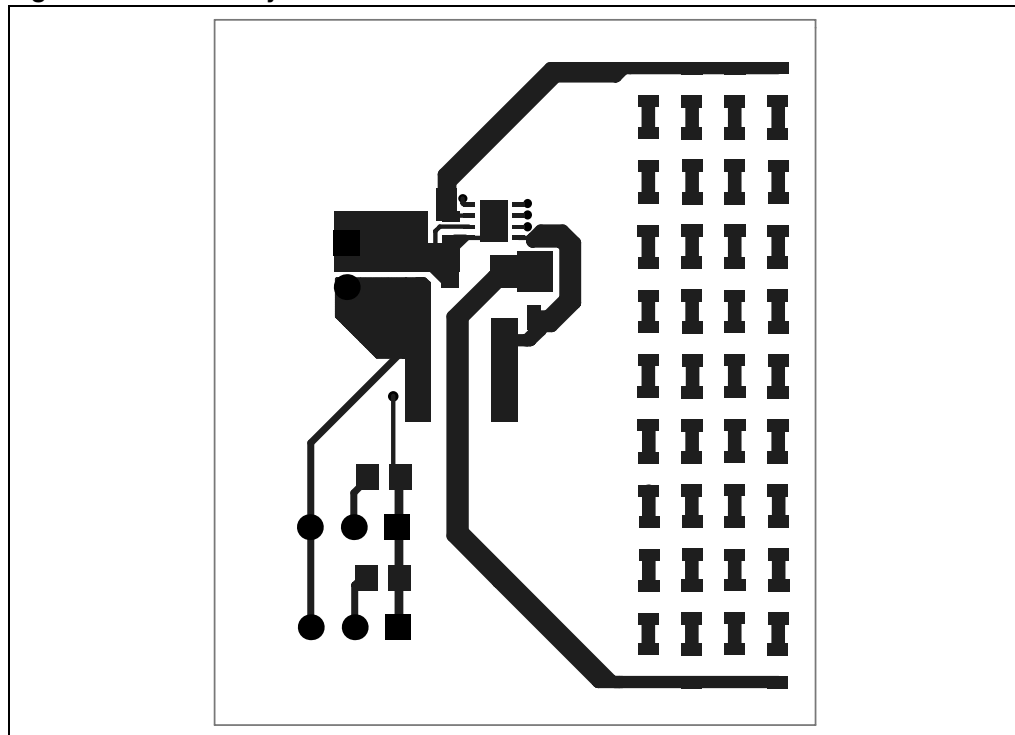
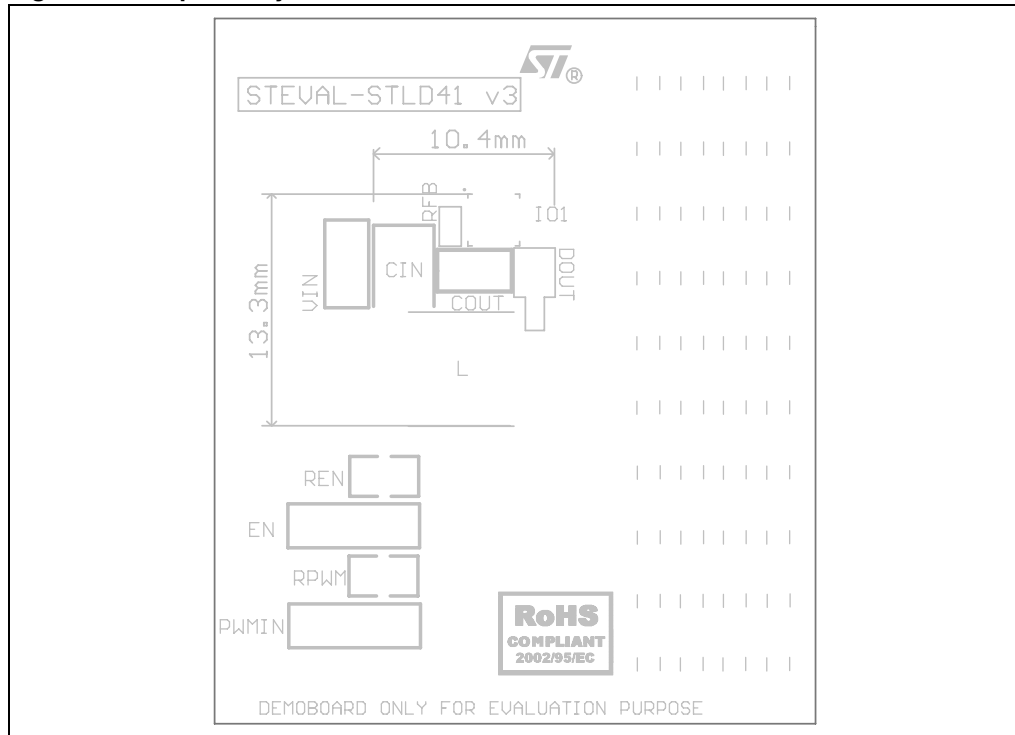

Figure 6. Top overlay



# 8 Typical performance characteristics

Figure 7. Eff. vs.  $V_{IN}$ , 6 x 6 LEDs,  $V_{OUT} = 24$  V Figure 8. Eff. vs.  $V_{IN}$ , 5 x 7 LEDs,  $V_{OUT} = 27$  V

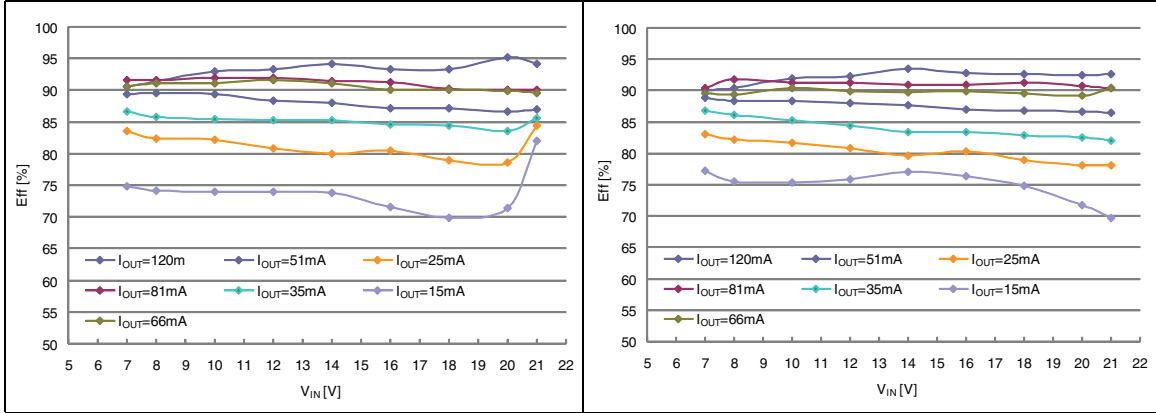

Figure 9. Eff. vs.  $V_{IN}$ , matrix 4 x 9 LEDs,  $V_{OUT} = 33$  V

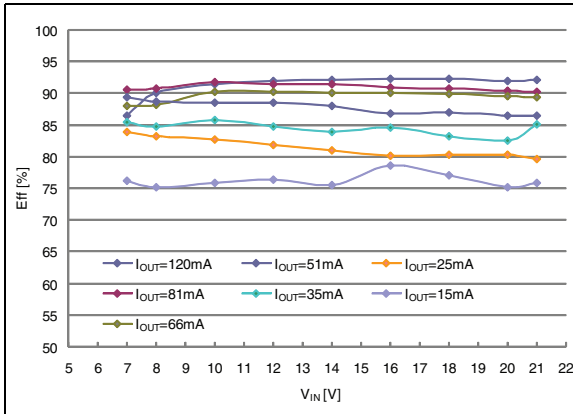

Figure 10. Application eff. vs.  $V_{IN}$ , matrix 4 x 10 LEDs

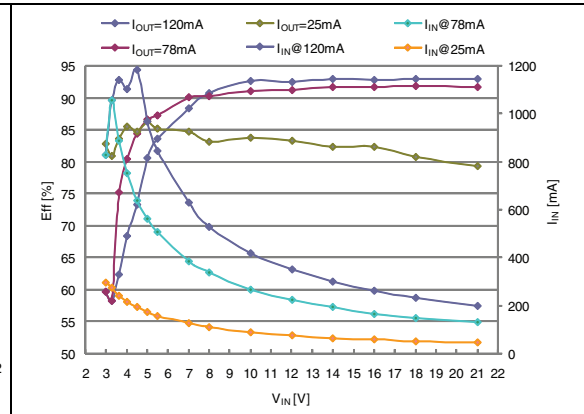

Figure 11. Output current regulation at 4x10 LEDs

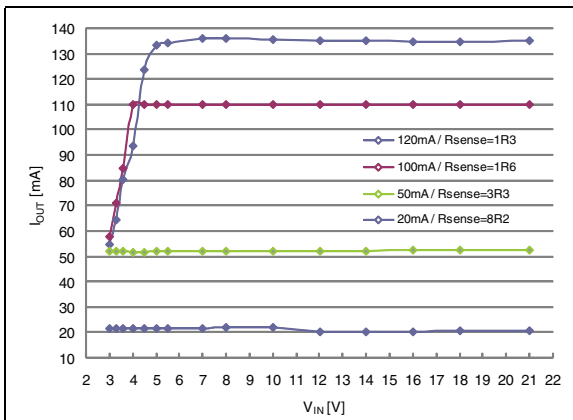
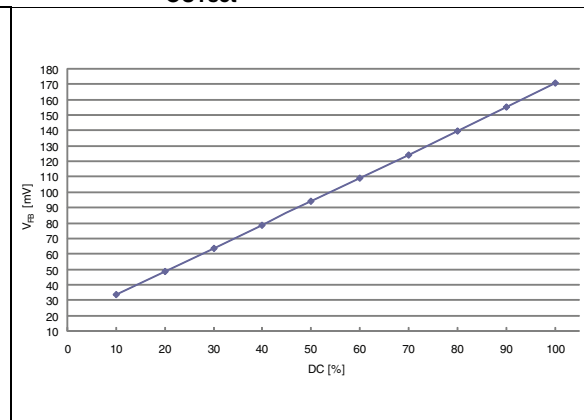

Figure 12.  $V_{FB}$  vs. PWM 2.5 kHz,  $V_{IN} = 5.5$  V,  $I_{OUTset} = 120$  mA



## 9 Package mechanical data

In order to meet environmental requirements, ST offers these devices in different grades of ECOPACK<sup>®</sup> packages, depending on their level of environmental compliance. ECOPACK<sup>®</sup> specifications, grade definitions and product status are available at: [www.st.com](http://www.st.com). ECOPACK<sup>®</sup> is an ST trademark.

**Table 7. DFN8 (3 x 3 mm) mechanical data**

Dim.	mm.		
	Min.	Typ.	Max.
A	0.80	0.90	1.00
A1	0.00	0.02	0.05
b	0.25	0.30	0.35
D		3.00	
D2	2.234	2.384	2.484
E		3.00	
E2	1.496	1.646	1.746
e		0.65	
L	0.30	0.40	0.50

Figure 13. Package dimension DFN8 (3 x 3 mm)

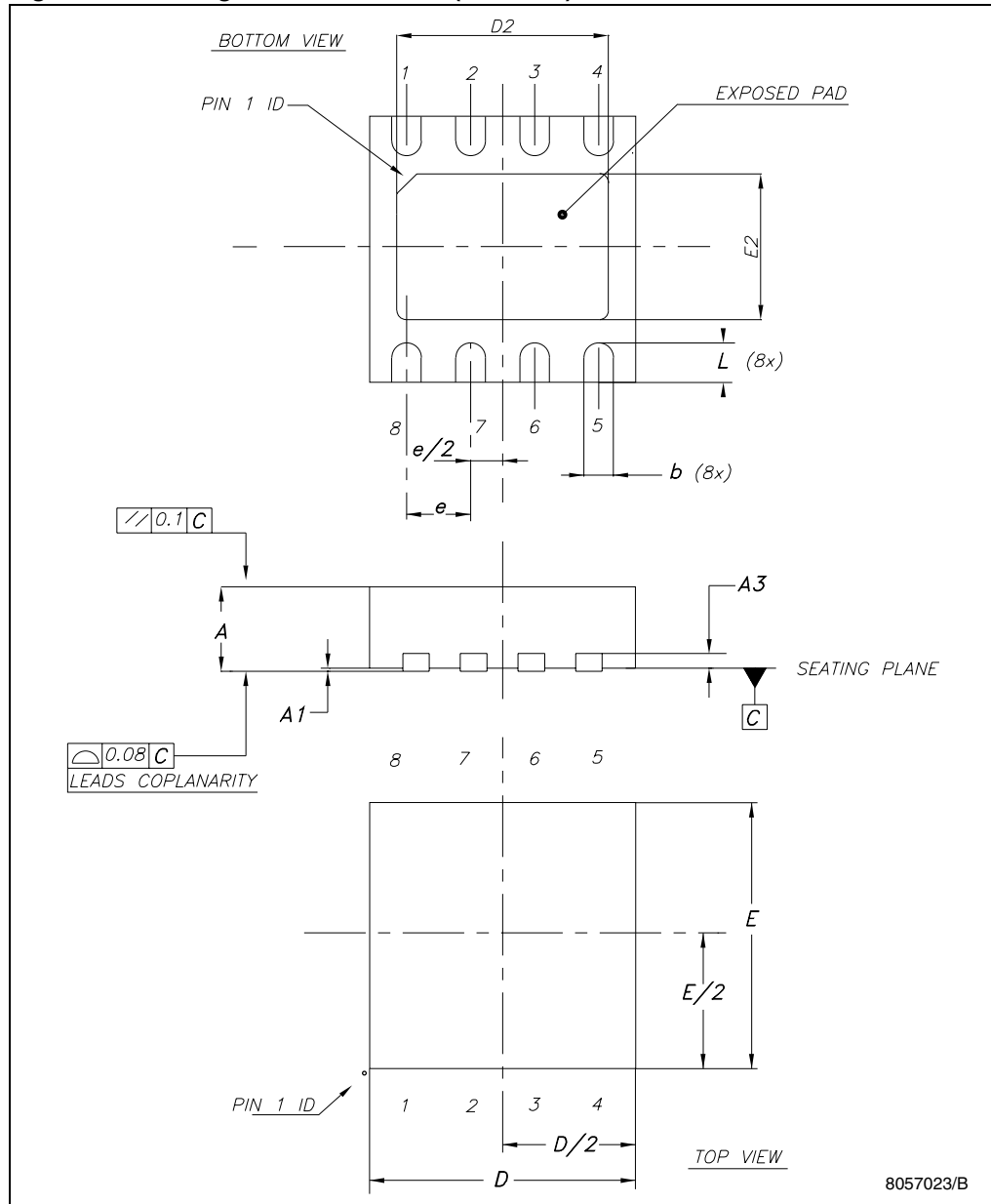

**Tape & reel QFNxx/DFNxx (3x3) mechanical data**

Dim.	mm.			inch.		
	Min.	Typ.	Max.	Min.	Typ.	Max.
A			180			7.087
C	12.8		13.2	0.504		0.519
D	20.2			0.795		
N	60			2.362		
T			14.4			0.567
Ao		3.3		0.130		
Bo		3.3		0.130		
Ko		1.1		0.043		
Po		4		0.157		
P		8		0.315		

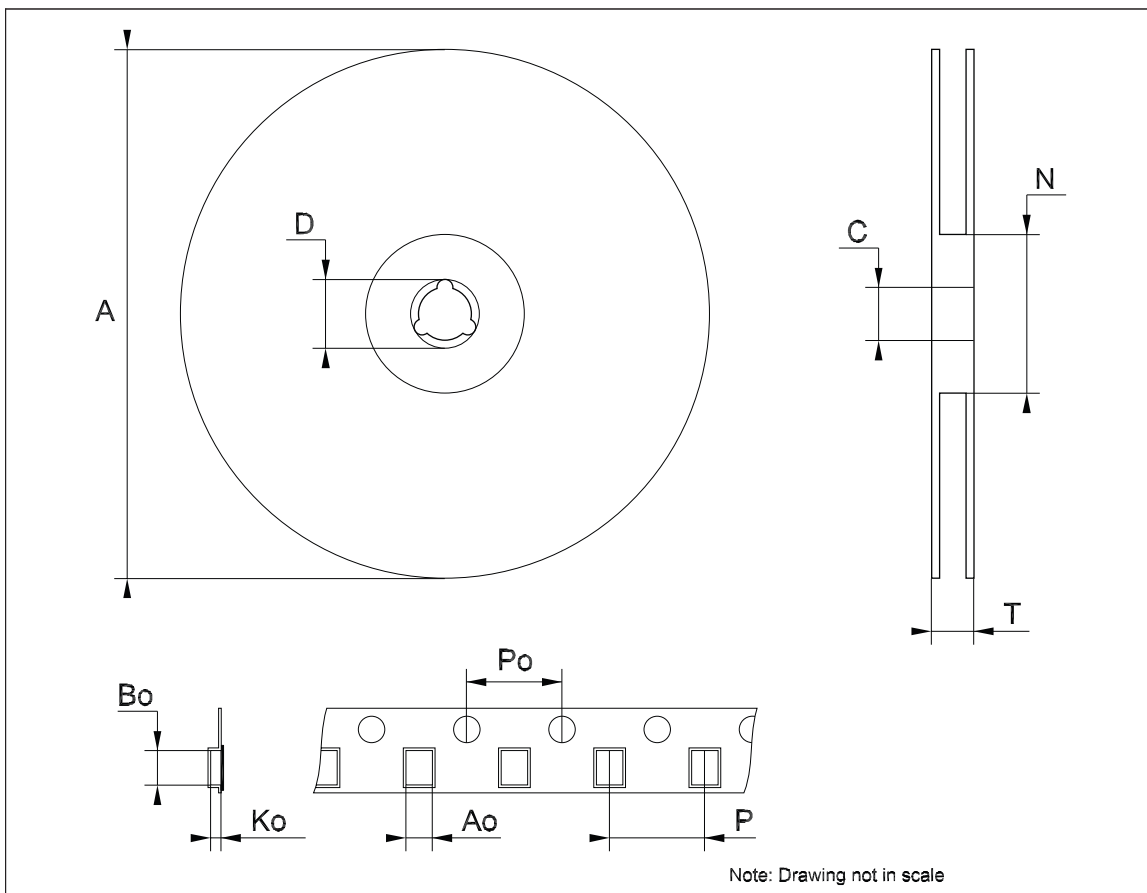
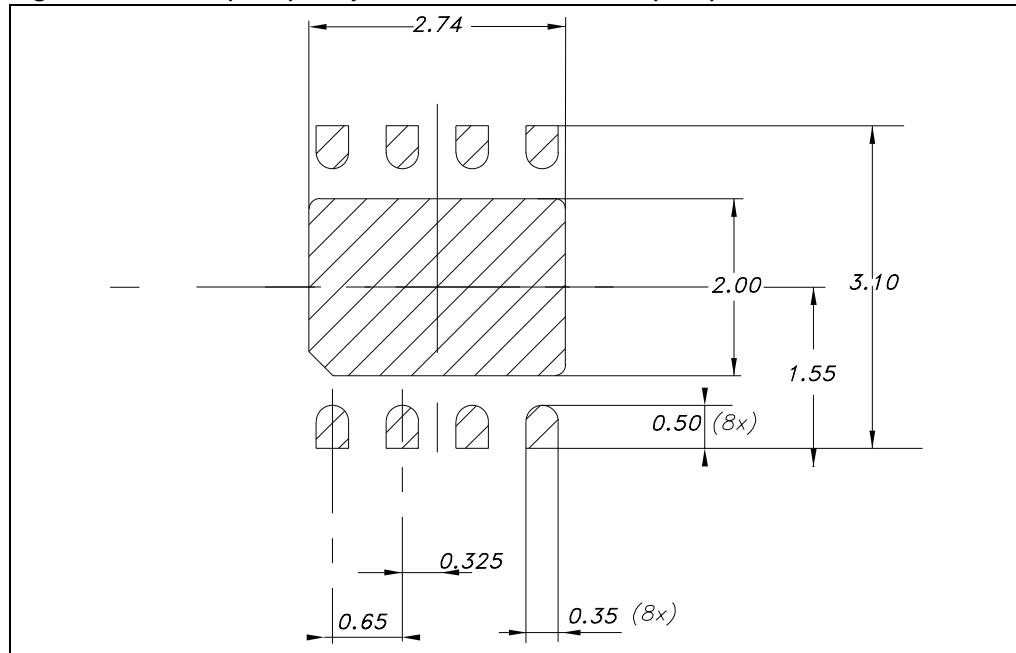



Figure 14. DFN8 (3 x 3) footprint recommended data (mm.)



## 10 Revision history

**Table 8. Document revision history**

Date	Revision	Changes
28-Sep-2011	1	Initial release.
16-Nov-2011	2	Change value 1.8 MHz ==> 1.4 MHz: <a href="#">Features on page 1</a> .

**Please Read Carefully:**

Information in this document is provided solely in connection with ST products. STMicroelectronics NV and its subsidiaries ("ST") reserve the right to make changes, corrections, modifications or improvements, to this document, and the products and services described herein at any time, without notice.

All ST products are sold pursuant to ST's terms and conditions of sale.

Purchasers are solely responsible for the choice, selection and use of the ST products and services described herein, and ST assumes no liability whatsoever relating to the choice, selection or use of the ST products and services described herein.

No license, express or implied, by estoppel or otherwise, to any intellectual property rights is granted under this document. If any part of this document refers to any third party products or services it shall not be deemed a license grant by ST for the use of such third party products or services, or any intellectual property contained therein or considered as a warranty covering the use in any manner whatsoever of such third party products or services or any intellectual property contained therein.

**UNLESS OTHERWISE SET FORTH IN ST'S TERMS AND CONDITIONS OF SALE ST DISCLAIMS ANY EXPRESS OR IMPLIED WARRANTY WITH RESPECT TO THE USE AND/OR SALE OF ST PRODUCTS INCLUDING WITHOUT LIMITATION IMPLIED WARRANTIES OF MERCHANTABILITY, FITNESS FOR A PARTICULAR PURPOSE (AND THEIR EQUIVALENTS UNDER THE LAWS OF ANY JURISDICTION), OR INFRINGEMENT OF ANY PATENT, COPYRIGHT OR OTHER INTELLECTUAL PROPERTY RIGHT.**

**UNLESS EXPRESSLY APPROVED IN WRITING BY TWO AUTHORIZED ST REPRESENTATIVES, ST PRODUCTS ARE NOT RECOMMENDED, AUTHORIZED OR WARRANTED FOR USE IN MILITARY, AIR CRAFT, SPACE, LIFE SAVING, OR LIFE SUSTAINING APPLICATIONS, NOR IN PRODUCTS OR SYSTEMS WHERE FAILURE OR MALFUNCTION MAY RESULT IN PERSONAL INJURY, DEATH, OR SEVERE PROPERTY OR ENVIRONMENTAL DAMAGE. ST PRODUCTS WHICH ARE NOT SPECIFIED AS "AUTOMOTIVE GRADE" MAY ONLY BE USED IN AUTOMOTIVE APPLICATIONS AT USER'S OWN RISK.**

Resale of ST products with provisions different from the statements and/or technical features set forth in this document shall immediately void any warranty granted by ST for the ST product or service described herein and shall not create or extend in any manner whatsoever, any liability of ST.

ST and the ST logo are trademarks or registered trademarks of ST in various countries.

Information in this document supersedes and replaces all information previously supplied.

The ST logo is a registered trademark of STMicroelectronics. All other names are the property of their respective owners.

© 2011 STMicroelectronics - All rights reserved

STMicroelectronics group of companies

Australia - Belgium - Brazil - Canada - China - Czech Republic - Finland - France - Germany - Hong Kong - India - Israel - Italy - Japan - Malaysia - Malta - Morocco - Philippines - Singapore - Spain - Sweden - Switzerland - United Kingdom - United States of America

[www.st.com](http://www.st.com)

