

Features and Benefits

- Two identical interface channels for remote sensor units
- Two connection modes: connection to OUTx and RETx or connection to OUTx and GND pin
- 16 bit Standard SPI for control and diagnosis via a microcontroller
- Supply voltage for each remote unit with a supply current up to 45mA
- Current limitation with an analog feed back loop for each channel
- Receive data from the remote unit by current modulation with a transmission rate of 10kHz
- Transmission of data to the remote unit via PWM voltage pulses
- Data input/output can be directly connected to a microcontroller input/output (CMOS)
- Low current consumption
- All pins to the external interface are short-circuit and high-voltage protected
- High immunity against cross coupling between the two channels
- The current modulation provides high noise immunity for data transfer

Application

- Remote automotive sensors (between ECU and sensors).

Ordering Information

Part No.
MLX16303

Temperature Suffix
E (-40°C to 85°C)

Package Code
DC (SOIC16, 150 mil)

1. Functional Diagram

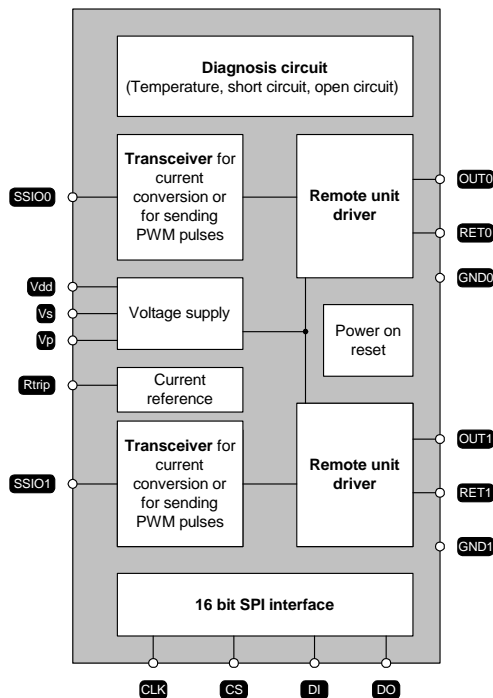

2. Description

This interface IC is designed for remote automotive sensors, especially between a main ECU and remote (sensor) units. It contains two identical interfaces and the main task of each interface is to supply one remote unit and to receive digital information from the same remote unit. It is also possible to send data as PWM voltage pulses to the remote unit, for example to program the remote unit for its special application. This is done by one active wire: the interface supplies the external unit with a pre-regulated voltage, the external unit transmits the digital information back to the interface by current modulation. A continuous diagnosis of the IC is running in the background. The diagnosis results can be requested by a microcontroller using the SPI interface.

TABLE OF CONTENTS

FEATURES AND BENEFITS	1
APPLICATION	1
ORDERING INFORMATION.....	1
1. FUNCTIONAL DIAGRAM.....	1-1
2. DESCRIPTION.....	2-1
3. ABSOLUTE MAXIMUM RATINGS	3
4. MLX16303 ELECTRICAL SPECIFICATIONS	6
5. GENERAL DESCRIPTION	11
6. UNIQUE FEATURES.....	18
7. RELIABILITY INFORMATION.....	19
8. ESD PRECAUTIONS.....	19
9. DISCLAIMER	20

3. Absolute Maximum Ratings

All voltages are referenced to the GND pins potential if no other voltage potential is mentioned.

Parameter	Symbol	min.	max.	Unit
Supply Voltage at VS	Vvs	-0.6	8	V
Supply Voltage at VDD	Vvdd	-0.6	5.1	V
Programming Voltage at VP (the 40V can only be present during load dump (< =400 ms) otherwise the max voltage will be 24V for 2 minutes)	Vvp	-0.6	40	V
Voltage at OUT0, OUT1 (the 40V can only be present during load dump (< =400 ms) otherwise the max voltage will be 24V for 2 minutes)	VOUT0, VOUT1	-0.6	40	V
Voltage at RETURN0, RETURN1	VRETURN0, VRETURN1	-0.6	40	V
Supply Current at VS (worst case) (I vs max = [Isrc OUT0 max = Isrc OUT1 max] *1.1, the factor 1.1 includes the internal current consumption)	lvs		220	mA
Supply Current at VS (under condition that it is guaranteed by SW that never both channels with short circuit condition are switched on at the same time) (lvs max = [100mA + 45mA] *1.1, the factor 1.1 includes the internal current consumption)	lvs		160	mA
Supply Current at VDD	lvdd		1	mA
Source Current at OUT0, OUT1	lsrcOUT0, lsrcOUT1		100	mA
Source Current limitation at OUT0, OUT1		3 x lthreshold	6 x lthreshold	mA
Sink Current at OUT0, OUT1 (if output is switched off)	lsinkOUT0, lsinkOUT1	-0.5	0.2	mA
DC Input Voltage at: SSIO0, SSIO1, CLK, CS, DI	VSSIO0, VSSIO1 Vclk, Vcs, Vdi	-0.5	5.5	V
DC Output Voltage at: SSIO0, SSIO1, DO	VSSIO0, VSSIO1 Vdo	-0.5	5.5	V
DC Input current per pin at: SSIO0, SSIO1, CLK, CS, DI	ISSIO0, ISSIO1 lclk, lcs,		1	mA

Parameter	Symbol	min.	max.	Unit
	Idi			
DC Output current per pin at: SSIO0, SSIO1, DO	ISSIO0 ISSIO1 Ido		1	mA
Resistor to GND at RTRIP	Rrtrip	35k	75k	Ω
Temperatures:				
operating ambient temperature range	Tamb	-40	85	$^{\circ}\text{C}$
operating junction temperature range	Tj	-40	150	$^{\circ}\text{C}$
storage temperature range	Tsto	-50	125	$^{\circ}\text{C}$
Thermal resistance:	Rthjc		30	k/W
Thermal resistance junction to pin				

Exceeding the absolute maximum ratings may cause permanent damage. Exposure to absolute-maximum-rated conditions for extended periods may affect device reliability.

Pinout

1 ■ SSIO1	RETURN1	16 ■
2 ■ VDD (5V)	VSS ret1	15 ■
3 ■ RTRIP	OUT1	14 ■
4 ■ DI	VP	13 ■
5 ■ DO	VS	12 ■
6 ■ CS	OUT0	11 ■
7 ■ CLK	VSS	10 ■
8 ■ SSIO0	RETURN 0	9 ■

Pin description

PIN NR.	SHORT NAME	DESCRIPTION	I/O	A/D
1	SSIO1	Communication pin channel 1	I/O	D
2	VDD	Supply voltage for Digital (5V)	I	D
3	RTRIP	External trip resistor	I	A
4	DI	Digital input	I	D
5	DO	Digital output	O	D
6	CS	Chip select	I	D
7	CLK	External clock	I	D
8	SSIO0	Communication pin channel 0	I/O	D
9	RETURN0	Return channel 0	I	A
10	VSS	GND 0	I	A/D
11	OUT0	Out channel 0	O	A
12	VS	Supply voltage	I	A
13	VP	Programmation voltage	I	A
14	OUT1	Out channel 1	O	A
15	VSS RETURN1	GND 1	I	A
16	RETURN1	Return channel 1	I	A

4. MLX16303 electrical specifications

Tamb = -40 to 85°C and Tj = -40 to 150°C

VS operation supply voltage range 4.9V to 7.7 V (**Remote unit connection OUTx to RETx pin**) or

VS operation supply voltage range 6.0V to 7.7 V (**Remote unit connection OUTx to GND pin**)

VP programming voltage range 9.6V to 16.2V

All voltages are referenced to the GND pins potential if no other voltage potential is mentioned

Parameter	Symbol	Conditions	Min	Max	Units
VS (sidesat connection OUTx to RETx pin)					
Supply Voltage Range	Vvs		4.9	7.7	V
Supply current OUT0 and OUT1 switched off	lvsoff			6	mA
Supply current OUT0 and OUT1 switched on At 6.0V ≤ VS ≤ 7.7V, IOOUT0 = IOOUT1 = 45 mA	lvson			100	mA
Supply current OUT0 and OUT1 switched on At 4.9V ≤ VS ≤ 6.0V, IOOUT0 = IOOUT1 = 35 mA	lvson			80	mA
VS (sidesat connection OUTx to GND pin)					
Supply Voltage Range	Vvs		6.0	7.7	V
Supply current OUT0 and OUT1 switched off	lvoff			6	mA
Supply current OUT0 and OUT1 switched on IOOUT0 = IOOUT1 = 45 mA	lvson			100	mA
VDD					
VDD Voltage Range	Vvdd		4.9	5.1	V
VDD Supply current	lvdd			1.5	mA
VP threshold					
Threshold Voltage for entering in Programming Mode (limits are relative to Vdd, rising edge)	Vvp	@25°C	9.4	9.6	V
Hysteresis of threshold Voltage for entering in Programming Mode (limits are relative to Vdd)		@25°C	0.05	0.15	V
VP					
Programming Voltage Range	Vvp		9.6	16.2	V

Itrip: specified value is for Vdd=5V (treshold is relative to Vdd)					
	Ithreshold	Rtrip=56 kOhms	Ithres- hold	Ithres- hold	mA
Current threshold for the rising edge (1)			14	24	
Hysteresis on current threshold			1	3.5	
OUT0 and OUT1					
Voltage drop between Vs and Out (Ioutx ≤ 45 mA for 6.0 V < VS < 7.7V, Ioutx ≤ 35 mA for 4.9 V < VS < 6.0 V)	Vout0_sat Vout1_sat			0.6	V
Switch on Time via SPI until 90% of Voutx is reached (with an output capacitance 120nF, Switch ON time start after the end of the SPI command)	tout0switchon, tout1switchon		3	30	µs
Switch off Time via SPI until 10% of Voutx is reached (with an output capacitance 120nF)	tout0switchoff, tout1switchoff		30	250	µs
Short Circuit to GND diagnosis threshold: Resistance from OUTx to GND	Rout0srtgnd, Rout1srtgnd		280	4.5K	Ω
Debounce time	tout0srtgndq, tout1srtgndq		500	2000	µs
Faults are latched. No debounce time for the release.	tout0srtgnddq, tout1srtgnddq		0	0	µs
Short Circuit to battery diagnosis threshold: Resistance from OUTx to battery	Rout0srbat, Rout1rbat		25	2.5K	Ω
OUTx: Voltage limit	Vout0>>, Vout1>>		Vs	Vs + 8%V	
Debounce time	tout0srbatq, tout1srbatq		500	2000	µs
Short Circuit to according RETURNx diagnosis threshold: Resistance from OUTx to according RETURNx	Rout0srtret0, Rout1srtret1		280	4.5K	Ω
Debounce time	tout0srtret0q, tout1srtret1q		500	2000	µs
Open loop (IOUTx) low current limit (with Rtrip = 56K) (remark: nominally equal to Ithreshold/10)	Iout0<<, Iout1<<		0.5	4.0	mA
Debounce time	tout0openret0q, tout1openret1q		500	2000	µs

(1) Definition of theoretical equation of Ithreshold: $I_{threshold} \text{ (mA)} = 960/R_{trip} \text{ (kOhms)}$

Non Programming Mode: connection OUTx to RETx						
Voltage Range (voltage between Out and Return line !) Ioutx = 0mA ... 35mA	4.9V ≤ VS ≤ 6.0V	Vout0, Vout1		4.15	5.5	V
Voltage Range (voltage between Out and Return line !) Ioutx = 0mA ... 45mA	6.0V ≤ VS ≤ 7.7V	Vout0, Vout1		5.25	7.2	V
Programming Mode: connection OUTx to RETx						
Low Level Voltage Range 9.6V ≤ VP ≤ 16.2V 4.9V ≤ VS ≤ 7.7V (voltage Voutx between Out and Return line !) Ioutx = 0mA ... 20mA		Vout0, Vout1		4.15	7.2	V
High Level Voltage Range 9.6V ≤ VP ≤ 16.2V 4.9V ≤ VS ≤ 7.7V (voltage Voutx between Out and Return line !) Ioutx = 0mA ... 20mA		Vout0, Vout1		8.9	15.9	V
Non Programming Mode: connection OUTx to GND						
Voltage Range (voltage between Out and GND !) Ioutx = 0mA ... 45mA	6.0V ≤ VS ≤ 7.7V	Vout0, Vout1		5.4	7.2	V
Programming Mode: connection OUTx to GND						
Low Level Voltage Range 9.6V ≤ VP ≤ 16.2V 6.0V ≤ VS ≤ 7.7V (voltage Voutx between Out and GND !) Ioutx = 0mA ... 20mA		Vout0, Vout1		5.4	7.2	V
High Level Voltage Range 9.6V ≤ VP ≤ 16.2V 6.0V ≤ VS ≤ 7.7V (voltage Voutx between Out and GND !) Ioutx = 0mA ... 20mA		Vout0, Vout1		9.0	16.0	V

Edges during voltage PWM (programming mode)					
Change from Voutx = low level to Voutx = high level (with C=120nF & load consuming >= 5mA! – connected)	tssio0vlh, tssio1vlh			10	µs
Change from Voutx = high level to Voutx = low level (with C=120nF & load –consuming >= 5mA! – connected)	tssio0vlh, tssio1vlh			50	µs
Capacity belonging to transmission				120	nF
Current pulse transmission rate			10		kHz
RETURN0, RETURN1					
Voltage drop. (Ioutx ≤ 45mA for 6.0V < VS < 7.7V, Ioutx ≤ 35 mA for 4.9V < VS < 6.0V)	Vreturn0_sat Vreturn1_sat		0	0.15	V
Short Circuit to GND diagnosis threshold: Resistance from RETURNx to GND only when required by user with channel off	Rreturn0srtgnd, Rreturn1srtgnd		280	4.5K	Ω
Qualification time	treturn0srtgndq, treturn1srtgndq		500	2000	µs
Short Circuit to battery diagnosis threshold: Resistance from RETURNx to battery	Rreturn0srtbat, Rreturn1srtbat		25	2.5K	Ω
RETx: Voltage limit	Vret0>>, Vret1>>		0.2	0.4	V
Qualification time	treturn0srtbatq, treturn1srtbatq		500	2000	µs
RETURNx overtemperature protection: Switch off Temperature of driver junction	treturn0tempoff, treturn1tempoff		140	160	°C
Switch on Temperature of driver junction	treturn0tempon, treturn1tempon		130	150	°C
SSIO0, SSIO1 (bidirectional CMOS)					
Input low level voltage SSIO0, SSIO1	VIL		-0.5	2.0	V
Input high level voltage SSIO0, SSIO1	VIH		3.8	5.5	V
Input leakage current SSIO0, SSIO1	IPL			+/- 0.5	µA
Input Hysteresis SSIO0, SSIO1	IPH		0.4		V
Output low voltage SSIO0, SSIO1 Ido = 1mA	VOL			0.45	V
Output high voltage SSIO0, SSIO1 Ido = -1mA	VOH		4		V
Ioutx range to get according SSIOx low level Rrtrip = 56k	ISSIO0high, ISSIO1high		18	45	mA
Ioutx range to get according SSIOx high level Rrtrip = 56k	ISSIO0low, ISSIO1low		5	16	mA

Response time at SSIOx to current change					
Change from loutx = low level to loutx = high level	tSSIO0ih, tSSIO1ih			20	μs
Change from loutx = high level to loutx = low level	tSSIO0ihl, tSSIO1ihl			20	μs
Current pulse transmission rate			10		kHz
SPI signals (CMOS)					
Input low level voltage DI, CS, CLK	VIL		-0.5	2.0	V
Input high level voltage DI, CS, CLK	VIH		3.8	5.5	V
Input leakage current DI, CS, CLK	IPL			±0.5	μA
Input Hysteresis DI, CS, CLK	IPH		0.4		V
Output low voltage DO Ido = 1mA	VOL			0.45	V
Clock frequency	fcl			4	MHz
Time between two following commands	TCMD			1	ms
Power dissipation				1	W

5. General Description

VS (supply Voltage VDD2)

The IC and the external units are powered via the VS pin. VS is connected to a powerunit IC output voltage.

VP (programming Voltage VDD1)

For the programming of the remote sensor the MLX16303 needs a higher voltage than VS. This voltage is named VP.

VP is connected to the battery via a reverse polarity protection diode (KL15). The VP pin may not source current under all conditions, especially after battery cut off.

VDD (5V Voltage)

Additional to the VS and VP MLX16303 needs a low current 5V voltage for the digital part and reference use.

This voltage is named VDD.

GND

The design has two GND pins.

RTRIP (External Current Reference Resistor)

The trip point is established by setting a reference current via an external reference resistor connected to ground. This reference current is needed for the current threshold of the current level-comparators. The current threshold can change with different resistors. This trip point is common for both channels.

OUT0, OUT1

OUTx makes a smoothed, very slow changing supply voltage for the external remote units according to the given electrical characteristic and monitors the output current. Each OUTx stage has a short circuit, over voltage and over temperature protection. The OUTx voltage can be switched on and off via SPI.

There are two modes possible:

Programming mode:

The OUTx voltage can be modulated by the bi-directional remote unit interface IC between two defined voltage ranges.

Non Programming mode:

No communication to the remote unit is possible.

The data transmission from the bi-directional remote unit interface IC to the external remote unit is only enabled during the programming mode. The programming mode is enabled and disabled by a SPI command.

RETURN0, RETURN1

The RETURNx pins make a low resistive connection to GND via a switched open collector transistor.

RETURNx will switch on if OUTx is switched on via SPI and vice versa.

SSIO0, SSIO1 (SideSatelliteInOut)

The SSIOx pins are bidirectional and have so multiple function.

In the non-programming mode (normal operation) the current at the pin OUTx is sensed and logical evaluated as high or low current level. In this operation the pin is used as an output pin. At high current at OUTx, SSIOx switches to low level (CMOS-compatible) and vice versa.

In the programming mode the SSIOx pins are used as input pins. Logical (CMOS-compatible) PWM pulses from a microcontroller modulate the OUTx between two defined voltage ranges (high and low). At

logical high at SSIOx, OUTx switches to high voltage level and vice versa. The SSIOx pins must have internal pull down 50kOhm (tolerance +/- 20%) resistors

Data transmission to the remote unit

It is possible to send data to the remote units. For this the OUTx voltage can be modulated by the bi-directional remote unit interface IC between two defined voltage ranges (high and low) using the pins SSIOx. The low level is the default level. This programming mode is enabled and disabled with an SPI command. The data transfer to the satellite is only possible in a limited battery range, otherwise a failure flag via SPI will be sent to microcontroller.

Data transmission from the remote unit

The data transmission from the external remote units to the bi-directional remote unit interface IC is done by varying the current level.

The quiescent current consumption of the external remote units is interpreted as logic high level at SSIOx pin. This means the SSIOx output drives the high level if the quiescent current consumption is sensed at the according OUTx pin. The remote units can switch on an additional fixed current, interpreted by the interface as logic low level at SSIOx. The SSIOx pins are CMOS-compatible and can be connected directly to a microcontroller.

SPI (Serial Parallel Interface)

The bi-directional remote unit IC is always the slave and the microcontroller the master of the 16bit serial parallel interface (SPI).

Data transfer timing

The standard SPI needs four CMOS-compatible pins.

The data input DI, the data output DO, the clock CLK and the chip select CS. The communication starts after the H-L edge of the CS signal (low active).

The DI and DO signals are synchronized with CLK (CLK idle is low).

The DI signal is latched from the data bus to an internal shift register with the falling edge of the CLK signal. The DO signal is shifted from an internal shift register to the data bus with the rising edge. The data output DO is in tri-state mode when the CS signal is high. The CS will be deactivated after each command. CLK is only active when CS is set to low level. MLX16303 has to monitor the exact number of CLK-pulses by counting them. The answer after the first command must be the answer of the NOP-command.

Communication protocol

The IC gets 16bit data from the microcontroller via SPI. The bit 0 - 2 will be interpreted as a command. The other bits are data.

When a command word is sent to the MLX16303 the first bit on the data bus must be bit0 (LSB) followed by the bits 1-15. The first bit of the answer word from MLX16303 must be bit0 followed by the bits 1-15. After transmission of a command with one command delay an 'answer word' is sent by MLX16303. If a command word matches completely with the known possible commands the respective action has to be done. The command word is fully reflected except for the bits that contain useful information in the command word.

If a sent SPI command is not a defined one all bits in the regarding answer word must be set to '1'.

SPI commands

Table of SPI commands

Command	Binary Code	Function
CMD_ONOFF	100b	Switch the remote units on/off (voltage OUTx)
CMD_DIAG1	010b	self diagnosis request when channel is ON
CMD_DIAG2	110b	self diagnosis request when channel is OFF
CMD_PROG	101b	Enable programming mode
CMD_NOP	001b	No Operation allows ECU to poll the answer of a previous command

CMD_ONOFF

Switches the OUTx voltage for the selected channel (remote unit) on or off. CO0/1 will only be considered if CS0/CS1 is set.

Command

														MSB															LSB
15	14	13	12	11	10	9	8	7	6	5	4	3	2	1	0														
0	0	0	0	0	0	0	0	0	CO1	CS1	CO0	CS0	CMD_ON_OFF																

Bit	Function
CMD_ON_OFF	100 binary
CS0	Selection of channel 0 0: channel 0 not selected 1: channel 0 selected
CO0	Channel 0 activate/deactivate 0: channel 0 deactivated 1: channel 0 activated
CS1	Selection of channel 1 0: channel 1 not selected 1: channel 1 selected
CO1	Channel 0 activate/deactivate 0: channel 0 deactivated 1: channel 1 activated

Answer

														MSB															LSB
15	14	13	12	11	10	9	8	7	6	5	4	3	2	1	0														
0	0	0	0	0	0	SC1	SC0	CMD_BYTE																					

Bit	Function
CMD_BYTE	Reflected lower byte of the command
SC0	Status of channel 0 0: channel 0 deactivated 1: channel 0 activated
SC1	Status of channel 1 0: channel 1 deactivated 1: channel 1 activated

CMD PROG

Enables the communication to send data to the remote units (programming mode). All other commands are not influenced by the status of the PM bit.

Command

MSB													LSB		
15	14	13	12	11	10	9	8	7	6	5	4	3	2	1	0
0	0	0	1	1	0	0	0	0	1	0	0	PM	CMD_PROG		

Bit	Function
CMD_PROG	101 binary
PM	0: programming mode OFF 1: programming mode ON

Answer

MSB													LSB		
15	14	13	12	11	10	9	8	7	6	5	4	3	2	1	0
0	0	0	1	1	0	0	PM	CMD_BYTE							

Bit	Function
CMD_BYTE	Reflected lower byte of the command
PM	Status about the actual programming mode status

The sent back bit PM can be set to '1' only if the supply for the programming mode (VP) is higher than Vvp (9.2 Volts).

CMD DIAG1

Request of the actual diagnosis result of the bi-directional remote unit interface IC. This means a copy of the actual status after an error, generated by the continuous diagnosis in the bi-directional remote unit interface IC, is answered back to the microcontroller. If an error is detected, the diagnosis affected bit is memorized until the connected microcontroller has sent a CMD_ONOFF with the channel selected and activated.

If the CMD is sent during the programming mode, the answer will be the same as for a wrong command

(all the bits are set to '1'). The CMD_DIAG1 is only possible in normal mode.
 If the CMD_DIAG1 is sent when the channel is off, the last status of the channel when it was on is replied.
 The diagnosis bits cannot change in off state even if an error appears (except for the bit DB4, over temperature bit, which represents the temperature status).

Command

													MSB			LSB		
15	14	13	12	11	10	9	8	7	6	5	4	3	2	1	0			
0	0	0	0	0	0	0	0	0	0	0	0	CS	CMD_DIAG					

Bit	Function		
CMD_DIAG	Bit2	Bit1	Bit0
	0	1	0
CS	Select the channel 0: Channel 0 selected 1: Channel 1 selected		

Answer

													MSB			LSB		
15	14	13	12	11	10	9	8	7	6	5	4	3	2	1	0			
DB7	DB6	DB5	DB4	DB3	DB2	DB1	DB0	CMD_BYTE										

Bit	Function
CMD_BYTE	Reflected lower byte
DB0	0: IOUTx OK 1: IOUTx to high
DB1	0: IOUTx OK 1: IOUTx to low
DB2	0: VOUTx OK 1: VOUTx to high
DB3	0: VRETx OK 1: VRETx to high
DB4	0: no fault 1: fault Over temperature (both channels are turned off)
DB5	0: Channel is on 1: Channel switched off
DB6	0
DB7	0

CMD_DIAG2

Request of the actual diagnosis result of the bi-directional remote unit interface IC after an error has occurred, the channel was switched off and the exact errortyp (checked with CMD_DIAG1) is still unclear.

If the CMD is sent during the programming mode, the answer will be the same as for a wrong command (all the bits will be set to '1'). The CMD_DIAG2 is only possible in normal mode.

If the CMD_DIAG2 is sent when the channel is on, it is not a wrong command but the bit DB2 (CMD_DIAG2 valid or not) is set to '1' and all the diagnosis bits are set to '0' (except for the bit DB4, over temperature bit, which represents the temperature status).

Command

											MSB			LSB	
15	14	13	12	11	10	9	8	7	6	5	4	3	2	1	0
0	0	0	0	0	0	0	0	0	0	0	0	CS	CMD_DIAG		

Bit	Function		
CMD_DIAG	Bit2	Bit1	Bit0
	1	1	0
CS	Select the channel 0: Channel 0 selected 1: Channel 1 selected		

Answer

											MSB			LSB	
15	14	13	12	11	10	9	8	7	6	5	4	3	2	1	0
DB7	DB6	DB5	DB4	DB3	DB2	DB1	DB0	CMD_BYTE							

Bit	Function
CMD_BYTE	Reflected lower byte
DB0	0: VOUTx OK 1: VOUTx < VOFFFLOW
DB1	0: VOUTx OK 1: VOUTx > VOFFHIGH
DB2	0: DIAGNOSIS 2 valid (channel OFF) 1: DIAGNOSIS 2 invalid (channel ON)
DB3	0
DB4	0: no fault 1: fault Over temperature (both channels are turned off)
DB5	0
DB6	0
DB7	0

CMD_NOP

No Operation allows ECU to poll the answer of a previous command.

Command

MSB													LSB		
15	14	13	12	11	10	9	8	7	6	5	4	3	2	1	0
1	0	0	1	0	0	0	1	0	0	0	0	0	CMD_NOP		

Bit	Function
CMD_NOP	001 binary

Answer

Both bytes are reflected.

MSB													LSB		
15	14	13	12	11	10	9	8	7	6	5	4	3	2	1	0
1	0	0	1	0	0	0	1	0	0	0	0	0	CMD_NOP		

6. Unique Features

The MLX16303 provides a voltage/current communication interface for remote units. The required diagnostics (short circuit, open circuit, temperature) are implemented on-chip, which drastically reduces the need for applying external, discrete components for obtaining this functionality.

Error detection and handling :

The MLX16303 has a full set of problem detection:

- Short circuit between OUT and GND
- Short circuit between OUT and BAT
- Short circuit between RET and GND
- Short circuit between RET and BAT
- Short circuit between OUT and RET
- Open circuit between OUT and RET
- Over temperature

If an error is detected the relevant channel will be switched off. After an error occurred it will be latched. The latched errors can only be reset by sending a CMD_ONOFF to the MLX16303. The ECU can read out the detected errors using the SPI interface. The error detection in MLX16303 reacts before any damaging or unreliable operation can occur.

Handling of an invalid SPI command

In the corresponding answer word all bits will be set to '1'.

Answer to an invalid SPI command:

15	14	13	12	11	10	9	8	7	6	5	4	3	2	1	0
1	1	1	1	1	1	1	1	1	1	1	1	1	1	1	1

7. Reliability Information

This Melexis device is classified and qualified regarding soldering technology, solderability and moisture sensitivity level, as defined in this specification, according to following test methods:

- IPC/JEDEC J-STD-020
Moisture/Reflow Sensitivity Classification For Nonhermetic Solid State Surface Mount Devices (classification reflow profiles according to table 5-2)
- EIA/JEDEC JESD22-A113
Preconditioning of Nonhermetic Surface Mount Devices Prior to Reliability Testing (reflow profiles according to table 2)
- CECC00802
Standard Method For The Specification of Surface Mounting Components (SMDs) of Assessed Quality
- EIA/JEDEC JESD22-B106
Resistance to soldering temperature for through-hole mounted devices
- EN60749-15
Resistance to soldering temperature for through-hole mounted devices
- MIL 883 Method 2003 / EIA/JEDEC JESD22-B102
Solderability

For all soldering technologies deviating from above mentioned standard conditions (regarding peak temperature, temperature gradient, temperature profile etc) additional classification and qualification tests have to be agreed upon with Melexis.

The application of Wave Soldering for SMD's is allowed only after consulting Melexis regarding assurance of adhesive strength between device and board.

Based on Melexis commitment to environmental responsibility, European legislation (Directive on the Restriction of the Use of Certain Hazardous substances, RoHS) and customer requests, Melexis has installed a Roadmap to qualify their package families for lead free processes also. Various lead free generic qualifications are running, current results on request.

For more information on manufacturability/solderability see quality page at our website:
<http://www.melexis.com/html/pdf/MLXleadfree-statement.pdf>

8. ESD Precautions

Electronic semiconductor products are sensitive to Electro Static Discharge (ESD). Always observe Electro Static Discharge control procedures whenever handling semiconductor products.

9. Disclaimer

Devices sold by Melexis are covered by the warranty and patent indemnification provisions appearing in its Term of Sale. Melexis makes no warranty, express, statutory, implied, or by description regarding the information set forth herein or regarding the freedom of the described devices from patent infringement. Melexis reserves the right to change specifications and prices at any time and without notice. Therefore, prior to designing this product into a system, it is necessary to check with Melexis for current information. This product is intended for use in normal commercial applications. Applications requiring extended temperature range, unusual environmental requirements, or high reliability applications, such as military, medical life-support or life-sustaining equipment are specifically not recommended without additional processing by Melexis for each application.

The information furnished by Melexis is believed to be correct and accurate. However, Melexis shall not be liable to recipient or any third party for any damages, including but not limited to personal injury, property damage, loss of profits, loss of use, interrupt of business or indirect, special incidental or consequential damages, of any kind, in connection with or arising out of the furnishing, performance or use of the technical data herein. No obligation or liability to recipient or any third party shall arise or flow out of Melexis' rendering of technical or other services.

© 2002 Melexis NV. All rights reserved.

For the latest version of this document, go to our website at:

www.melexis.com

Or for additional information contact Melexis Direct:

Europe and Japan:	All other locations:
Phone: +32 13 67 04 95	Phone: +1 603 223 2362
E-mail: sales_europe@melexis.com	E-mail: sales_usa@melexis.com

ISO/ TS 16949 and ISO 14001 Certified