

Structure	Silicon monolithic integrated circuit
Product	Power management switch IC
Type	BD6529GUL
Feature	Single channel of low on resistance (Typ = 100mΩ) N-channel MOSFET built in Reverse-current protection when power switch off Output discharge circuit

◇Absolute maximum ratings (Ta=25°C)

Parameter	Symbol	Rating	Unit
Supply voltage	V _{DD}	-0.3 ~ 6.0	V
VIN voltage	V _{IN}	-0.3 ~ 6.0	V
EN voltage	V _{EN}	-0.3 ~ V _{DD} + 0.3	V
VOU voltage	V _{OUT}	-0.3 ~ 6.0	V
Storage temperature	T _{STG}	-55 ~ 150	°C
Power dissipation	P _d	575 ^{*1}	mW

*1 Mounted on 50mm * 58mm * 1.75mm glass-epoxy PCB. Derating: 4.6mW/°C above Ta = 25°C.

* This product is not designed for protection against radioactive rays.

◇Operating conditions

Parameter	Symbol	MIN	TYP	MAX	Unit
Operating voltage	V _{DD}	2.7	3.3	4.5	V
Switch input voltage	V _{IN}	0	1.2	2.7	V
Operating temperature	T _{OPR}	-25	25	85	°C
Output current	I _{LO}	0	-	500	mA

◇ Electric characteristics (Unless otherwise specified, $V_{DD} = 3.3V$, $V_{IN} = 1.2V$, $T_a = 25^\circ C$)

Parameter	Symbol	Limits			Unit	Condition
		MIN	TYP	MAX		
Operating current	I_{DD}	-	20	30	μA	$V_{EN} = 1.2V$
Standby current	I_{STB}	-	0.01	1	μA	$V_{EN} = 0V$
EN input voltage	V_{ENH}	1.2	-	-	V	High level input
	V_{ENL}	-	-	0.4	V	Low level input
EN input current	I_{EN}	-1.0	-	1.0	μA	$V_{EN} = 0V$ or $V_{EN} = 1.2V$
ON resistance	R_{ON}	-	100	-	$m\Omega$	$I_{OUT} = 500mA$
Switch leakage current	I_{LEAK}	-	0.01	10	μA	$V_{EN} = 0V$, $V_{OUT} = 0V$
Output turn on rise time	T_{ON1}	-	0.5	1.0	ms	$R_L = 10\Omega$ $V_{OUT} : 10\% \rightarrow 90\%$
Output turn on time	T_{ON2}	-	0.6	2.0	ms	$R_L = 10\Omega$ $V_{EN} \text{ High} \rightarrow V_{OUT} 90\%$
Output turn off fall time	T_{OFF1}	-	0.1	4	μs	$R_L = 10\Omega$ $V_{OUT} : 90\% \rightarrow 10\%$
Output turn off time	T_{OFF2}	-	1	6	μs	$R_L = 10\Omega$ $V_{EN} \text{ Low} \rightarrow V_{OUT} 10\%$
Discharge ON resistance	R_{DISC}	-	70	110	Ω	$I_{OUT} = -1mA$, $V_{EN} = 0V$
Discharge current	I_{DISC}	-	15	20	mA	$V_{OUT} = 3.3V$, $V_{EN} = 0V$

◇ Switch output turn ON/OFF timing

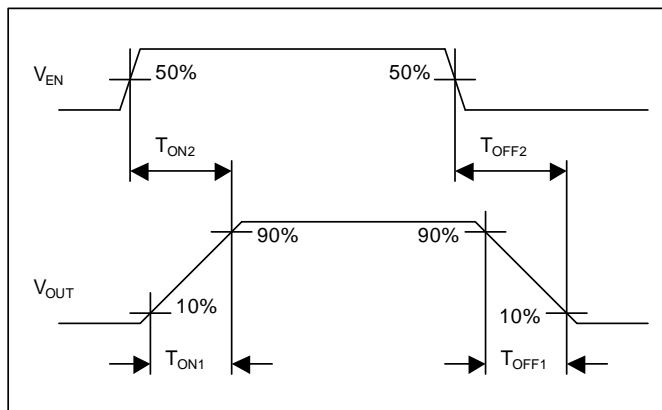

◇ Test circuit

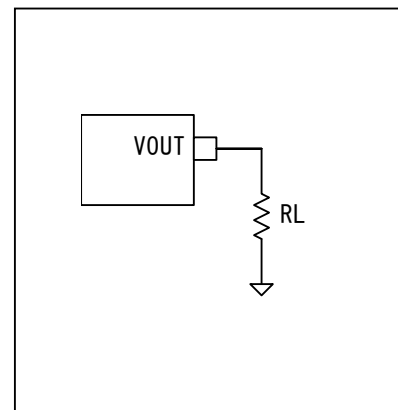

◇Block diagram

◇Pin number, Pin name

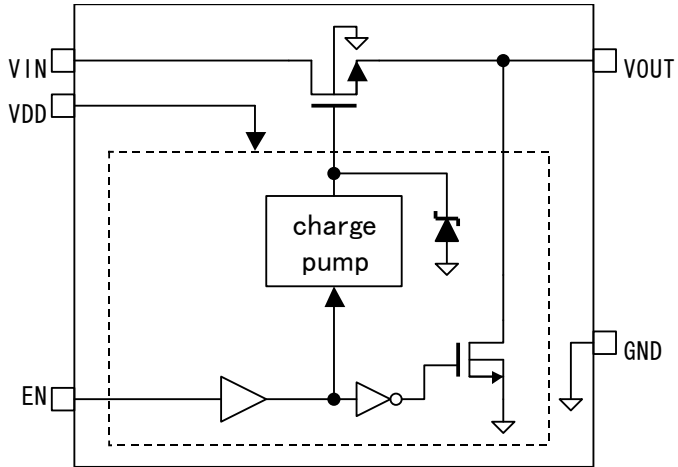

PIN number	Pin Name	Description
A3	GND	Ground
B2, B3	VOUT	Switch output
B1	VIN	Switch input
A1	VDD	Power supply
A2	EN	Enable input

◇Package outline

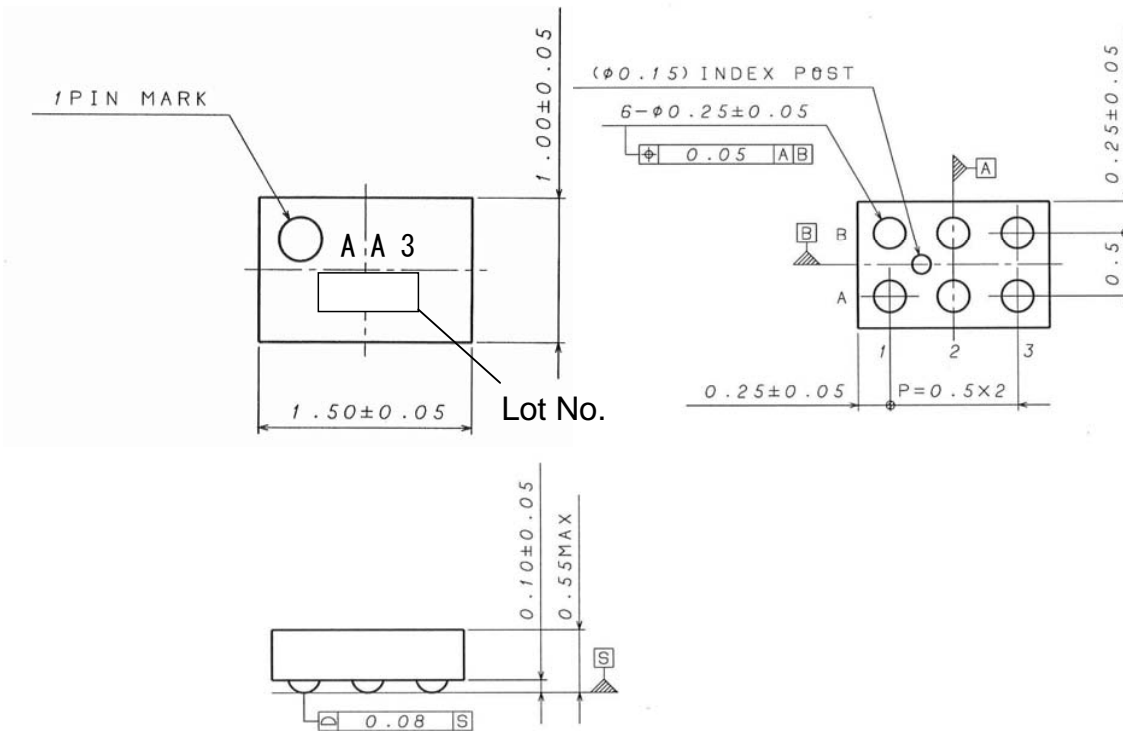

VCSP50L1 (Unit: mm)

REV. B

○Cautions on use

(1) Absolute Maximum Ratings

An excess in the absolute maximum ratings, such as supply voltage, temperature range of operating conditions, etc., can break down devices, thus making impossible to identify breaking mode such as a short circuit or an open circuit. If any special mode exceeding the absolute maximum ratings is assumed, consideration should be given to take physical safety measures including the use of fuses, etc.

(2) Power supply and GND line

Design PCB pattern to provide low impedance for the wiring between the power supply and the GND lines. Pay attention to the interference by common impedance of layout pattern when there are plural power supplies and GND lines. Especially, when there are GND pattern for small signal and GND pattern for large current included the external circuits, separate each GND pattern. Furthermore, for all power supply terminals to ICs, mount a capacitor between the power supply and the GND terminal. At the same time, in order to use a capacitor, thoroughly check to be sure the characteristics of the capacitor to be used present no problem including the occurrence of capacity dropout at a low temperature, thus determining the constant.

(3) GND voltage

Make setting of the potential of the GND terminal so that it will be maintained at the minimum in any operating state. Furthermore, check to be sure no terminals are at a potential lower than the GND voltage including an actual electric transient.

(4) Short circuit between terminals and erroneous mounting

In order to mount ICs on a set PCB, pay thorough attention to the direction and offset of the ICs. Erroneous mounting can break down the ICs. Furthermore, if a short circuit occurs due to foreign matters entering between terminals or between the terminal and the power supply or the GND terminal, the ICs can break down.

(5) Operation in strong electromagnetic field

Be noted that using ICs in the strong electromagnetic field can malfunction them.

(6) Input terminals

In terms of the construction of IC, parasitic elements are inevitably formed in relation to potential. The operation of the parasitic element can cause interference with circuit operation, thus resulting in a malfunction and then breakdown of the input terminal. Therefore, pay thorough attention not to handle the input terminals, such as to apply to the input terminals a voltage lower than the GND respectively, so that any parasitic element will operate. Furthermore, do not apply a voltage to the input terminals when no power supply voltage is applied to the IC. In addition, even if the power supply voltage is applied, apply to the input terminals a voltage lower than the power supply voltage or within the guaranteed value of electrical characteristics.

(7) External capacitor

In order to use a ceramic capacitor as the external capacitor, determine the constant with consideration given to a degradation in the nominal capacitance due to DC bias and changes in the capacitance due to temperature, etc.

(8) Thermal design

Perform thermal design in which there are adequate margins by taking into account the power dissipation (PD) in actual states of use.

Notes

No copying or reproduction of this document, in part or in whole, is permitted without the consent of ROHM Co.,Ltd.

The content specified herein is subject to change for improvement without notice.

The content specified herein is for the purpose of introducing ROHM's products (hereinafter "Products"). If you wish to use any such Product, please be sure to refer to the specifications, which can be obtained from ROHM upon request.

Examples of application circuits, circuit constants and any other information contained herein illustrate the standard usage and operations of the Products. The peripheral conditions must be taken into account when designing circuits for mass production.

Great care was taken in ensuring the accuracy of the information specified in this document. However, should you incur any damage arising from any inaccuracy or misprint of such information, ROHM shall bear no responsibility for such damage.

The technical information specified herein is intended only to show the typical functions of and examples of application circuits for the Products. ROHM does not grant you, explicitly or implicitly, any license to use or exercise intellectual property or other rights held by ROHM and other parties. ROHM shall bear no responsibility whatsoever for any dispute arising from the use of such technical information.

The Products specified in this document are intended to be used with general-use electronic equipment or devices (such as audio visual equipment, office-automation equipment, communication devices, electronic appliances and amusement devices).

The Products specified in this document are not designed to be radiation tolerant.

While ROHM always makes efforts to enhance the quality and reliability of its Products, a Product may fail or malfunction for a variety of reasons.

Please be sure to implement in your equipment using the Products safety measures to guard against the possibility of physical injury, fire or any other damage caused in the event of the failure of any Product, such as derating, redundancy, fire control and fail-safe designs. ROHM shall bear no responsibility whatsoever for your use of any Product outside of the prescribed scope or not in accordance with the instruction manual.

The Products are not designed or manufactured to be used with any equipment, device or system which requires an extremely high level of reliability the failure or malfunction of which may result in a direct threat to human life or create a risk of human injury (such as a medical instrument, transportation equipment, aerospace machinery, nuclear-reactor controller, fuel-controller or other safety device). ROHM shall bear no responsibility in any way for use of any of the Products for the above special purposes. If a Product is intended to be used for any such special purpose, please contact a ROHM sales representative before purchasing.

If you intend to export or ship overseas any Product or technology specified herein that may be controlled under the Foreign Exchange and the Foreign Trade Law, you will be required to obtain a license or permit under the Law.



Thank you for your accessing to ROHM product informations.
More detail product informations and catalogs are available, please contact us.

ROHM Customer Support System

<http://www.rohm.com/contact/>