



Wireless Components

7 x 5 Video Matrix Switch

TDA 6920 Version 1.0

Specification August 1999

Revision History: Current Version: 08.99		
Previous Version:Data Sheet		
Page (in previous Version)	Page (in current Version)	Subjects (major changes since last revision)

ABM®, AOP®, ARCOFI®, ARCOFI®-BA, ARCOFI®-SP, DigiTape®, EPIC®-1, EPIC®-S, ELIC®, FALC®54, FALC®56, FALC®-E1, FALC®-LH, IDEC®, IOM®, IOM®-1, IOM®-2, IPAT®-2, ISAC®-P, ISAC®-S, ISAC®-S TE, ISAC®-P TE, ITAC®, IWE®, MUSAC®-A, OCTAT®-P, QUAT®-S, SICAT®, SICOFI®, SICOFI®-2, SICOFI®-4, SICOFI®-4µC, SLICOFI® are registered trademarks of Infineon Technologies AG.

ACE™, ASM™, ASP™, POTSWIRE™, QuadFALC™, SCOUT™ are trademarks of Infineon Technologies AG.

Edition 03.99

**Published by Infineon Technologies AG i. Gr.,
SC,
Balanstraße 73,
81541 München**

© Infineon Technologies AG i. Gr. 25.08.99.
All Rights Reserved.

Attention please!

As far as patents or other rights of third parties are concerned, liability is only assumed for components, not for applications, processes and circuits implemented within components or assemblies.

The information describes the type of component and shall not be considered as assured characteristics.

Terms of delivery and rights to change design reserved.

Due to technical requirements components may contain dangerous substances. For information on the types in question please contact your nearest Infineon Technologies Office.

Infineon Technologies AG is an approved CECC manufacturer.

Packing

Please use the recycling operators known to you. We can also help you – get in touch with your nearest sales office. By agreement we will take packing material back, if it is sorted. You must bear the costs of transport.

For packing material that is returned to us unsorted or which we are not obliged to accept, we shall have to invoice you for any costs incurred.

Components used in life-support devices or systems must be expressly authorized for such purpose!

Critical components¹ of the Infineon Technologies AG, may only be used in life-support devices or systems² with the express written approval of the Infineon Technologies AG.

- 1 A critical component is a component used in a life-support device or system whose failure can reasonably be expected to cause the failure of that life-support device or system, or to affect its safety or effectiveness of that device or system.
- 2 Life support devices or systems are intended (a) to be implanted in the human body, or (b) to support and/or maintain and sustain human life. If they fail, it is reasonable to assume that the health of the user may be endangered.

Product Info

General Description

The TDA 6920 switches 7 video input sources to 5 outputs. Each output can be switched to only one input, but one input can be switched to all outputs. The C-input may be combined with one CVBS input as Y for Y+C (S-VHS) operation. Y+C operation is selected by bus.

Features

- Fast I²C-BUS controlled (max. 400 kHz)
- Cascadable (2 bus addresses)
- 7 CVBS inputs, 5 outputs
3 inputs with clamp disable by bus
- 1 input selectable as Y-input (S-VHS)
- 1 additional C-input (S-VHS)
- Y+C operation for S-VHS selected by bus
- Fully ESD protected
- -60 dB max. crosstalk at 5 MHz (P-DSO-28 only)

Application

- Television sets
- Satellite receivers

Package

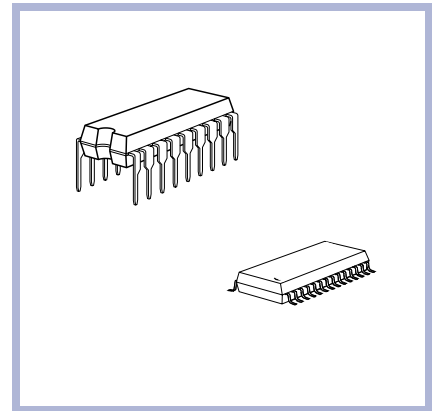

- Low operating voltage of 7.5 V
- 5V operation is possible with reduced output signals of max. 2 V_{pp}
- 15 MHz minimum bandwidth
- Noise insensitive clamping inputs
- low impedance off condition separate for each output

- Video mixing desks

Ordering Information

Type	Ordering Code	Package
TDA 6920	Q67000-A5200 GEG	P-DIP-18
TDA 6920X	Q67007-A5225 GEG	P-DSO-28

1

Table of Contents

1	Table of Contents	1-1
2	Product Description	2-1
2.1	Overview	2-2
2.2	Features	2-2
2.3	Application	2-2
2.4	Package Outlines	2-3
3	Functional Description	3-1
3.1	Pin Configuration	3-2
3.2	Pin Definition and Function	3-3
3.3	Pin Description	3-4
3.4	Functional Description	3-6
3.5	Block Diagram (P-DSO-28)	3-7
4	Applications	4-1
4.1	Circuits	4-2
4.1.1	Application Circuit P-DSO-28	4-2
4.1.2	Application Circuit P-DSO-28	4-3
4.1.3	Application Circuit P-DIP-18	4-4
5	Reference	5-1
5.1	Electrical Data	5-2
5.1.1	Absolute Maximum Ratings	5-2
5.1.2	Operating Range	5-3
5.1.3	AC/DC Characteristics	5-3
5.2	Address selection (fast I2C-Bus)	5-5
5.3	Data selection (fast I2C-BUS)	5-5
5.4	Data Mode Selections (fast I2C-Bus)	5-6
5.5	BUS Protocol (fast I2C-BUS)	5-6
5.6	Test Circuits	5-7
5.7	Electrical Diagramms	5-9

2 Product Description

Contents of this Chapter

2.1	Overview	2-2
2.2	Features	2-2
2.3	Application	2-2
2.4	Package Outlines	2-3

2.1 Overview

The TDA 6920 switches 7 video input sources to 5 outputs. Each output can be switched to only one input, but one input can be switched to all outputs. The C-input may be combined with one CVBS input as Y for Y+C (S-VHS) operation. Y+C operation is selected by bus.

2.2 Features

- Fast I²C-BUS controlled (max. 400 kHz)
- Cascadable (2 bus addresses)
- 7 CVBS inputs, 5 outputs, 3 inputs with clamp disable by bus
- 1 input selectable as Y-input (S-VHS)
- 1 additional C-input (S-VHS)
- Y+C operation for S-VHS, selected by bus
- Fully ESD protected
- -60 dB max. crosstalk at 5 MHz (P-DSO-28 only)
- Low operating voltage of 7.5 V
- 5V operation is possible with reduced output signals of max. 2 V_{pp}
- 15 MHz minimum bandwidth
- Noise insensitive clamping inputs
- low impedance off condition, separate for each output

2.3 Application

- Television sets
- Satellite receivers
- Video mixing desks

2.4 Package Outlines

P-DSO-28

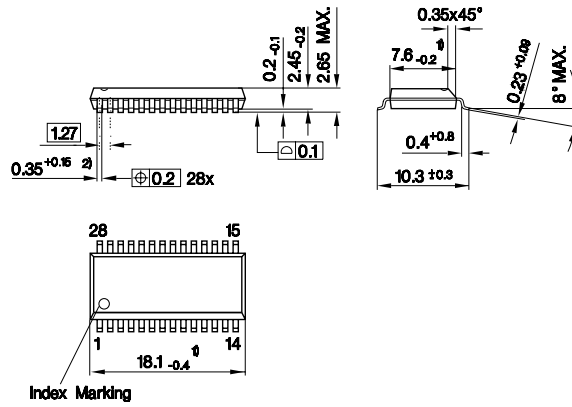

- 1) Does not include plastic or metal protrusion of 0.15 max. per side
- 2) Does not include dambar protrusion of 0.05 max. per side

P-DIP-18

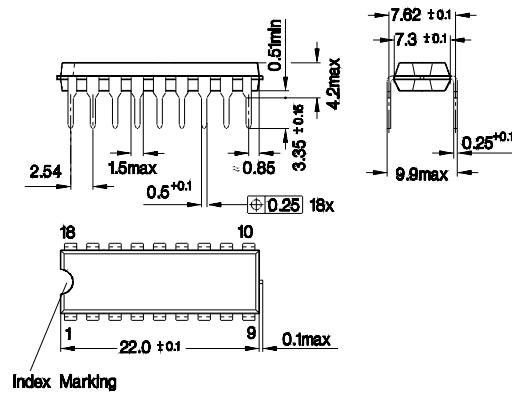

3 Functional Description

Contents of this Chapter

3.1	Pin Configuration	3-2
3.2	Pin Definition and Function.	3-3
3.3	Pin Description	3-4
3.4	Functional Description	3-6
3.5	Block Diagram (P-DSO-28)	3-7

3.1 Pin Configuration

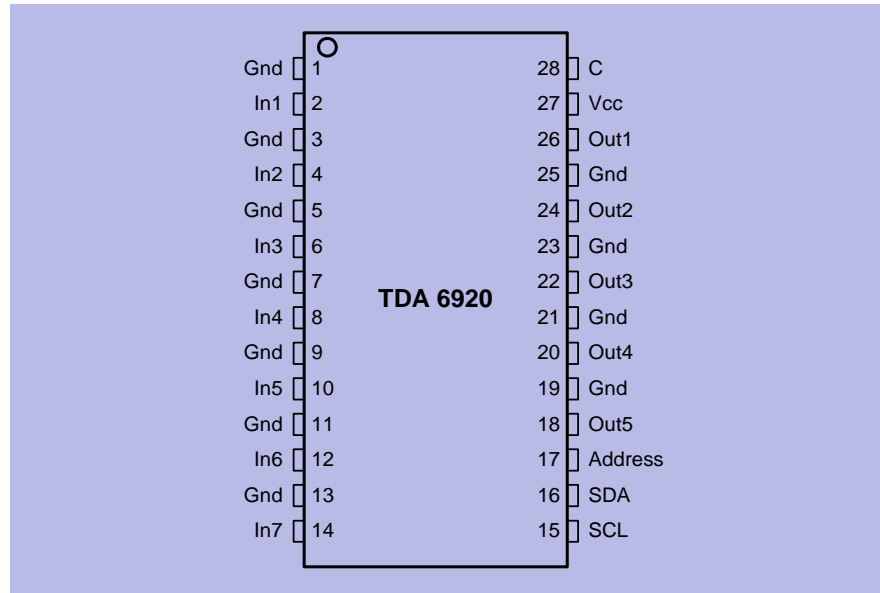

Pin_config_1.wmf

Figure 3-1 Pin Configuration P-DSO-28

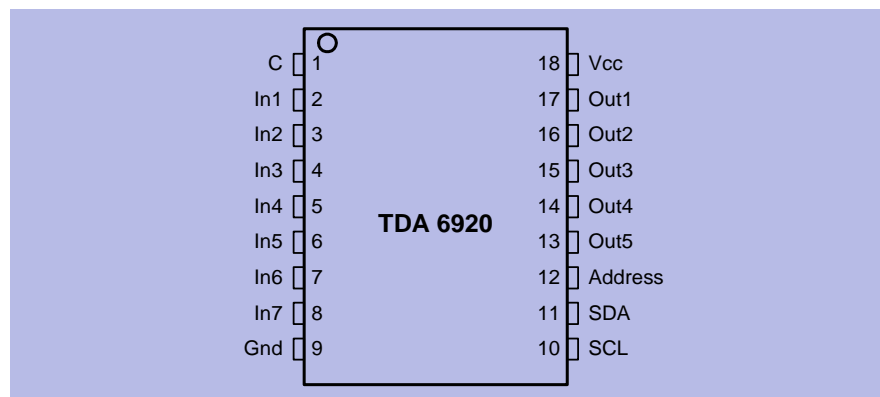

Pin_config_2.wmf

Figure 3-2 Pin Configuration P-DIP-18

3.2 Pin Definition and Function

Table 3-1 Pin Definition and Function			
Symbol	Pin		Function
	P-DIP-18	P-DIP-28	
GND	-	1	Signal + power supply ground
IN1	2	2	CVBS input 1
GND	-	3	Signal + power supply ground
IN2	3	4	CVBS input 2
GND	-	5	Signal + power supply ground
IN3	4	6	CVBS input 3
GND	-	7	Signal + power supply ground
IN4	5	8	CVBS input 4
GND	-	9	Signal + power supply ground
IN5	6	10	CVBS input 5
V ref3	-	11	Reference Voltage for external use
IN6	7	12	CVBS input 6
GND	9	13	Power supply ground
IN7	8	14	CVBS input 7
SCL	10	15	I ² C-Bus clock
SDA	11	16	I ² C-Bus data
Address	12	17	Address selection
OUT5	13	18	CVBS output 5
GND	-	19	Signal + power supply ground
OUT4	14	20	CVBS output 4
GND	-	21	Signal + power supply ground
OUT3	15	22	CVBS output 3
GND	-	23	Signal + power supply ground
OUT2	16	24	CVBS output 2
GND	-	25	Signal + power supply ground
OUT1	17	26	CVBS output 1
VCC	18	27	Positive power supply voltage
C	1	28	Separate color adding input for input 1

3.3 Pin Description

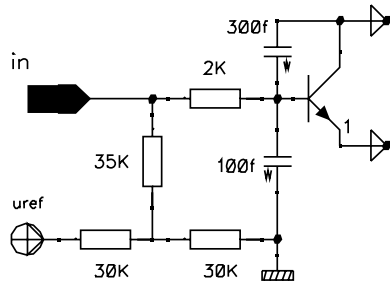

C (color input)

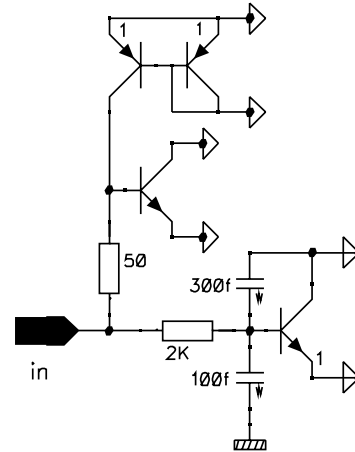

In 2,5,6,7 (CVBS input)

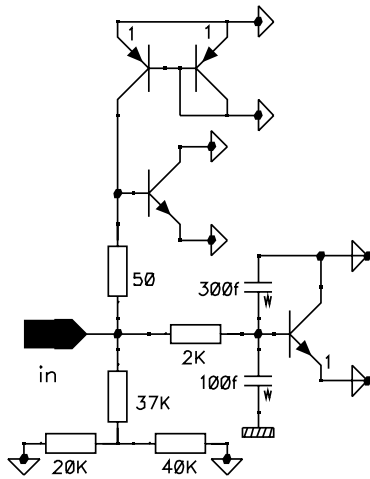

In 2,3,4 (CVBS input)

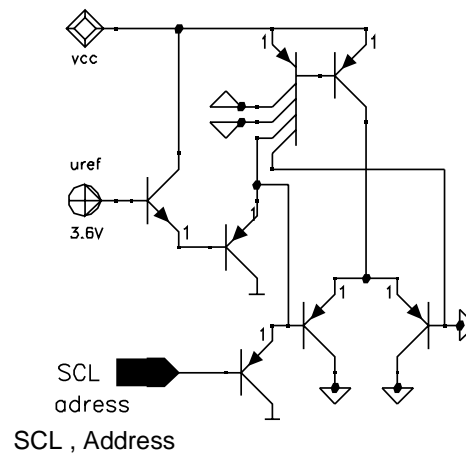

SCL , Address

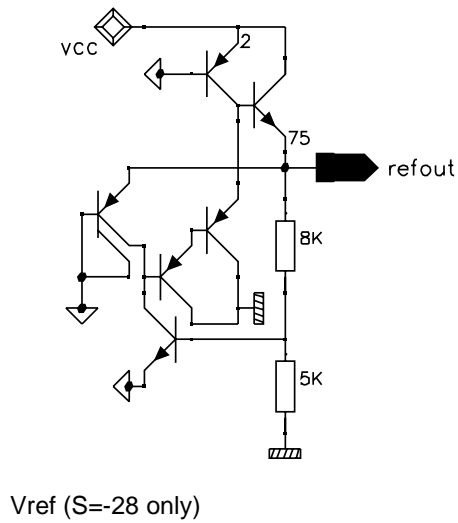
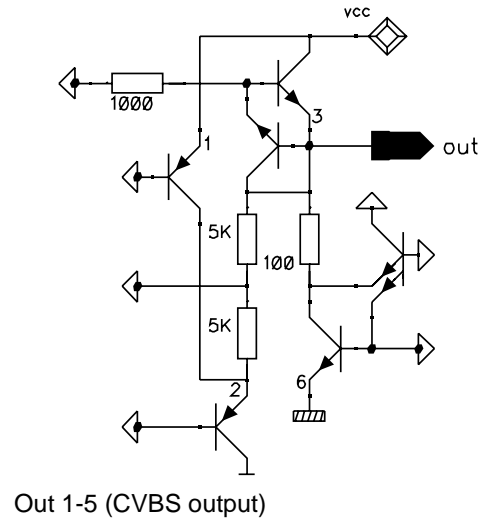
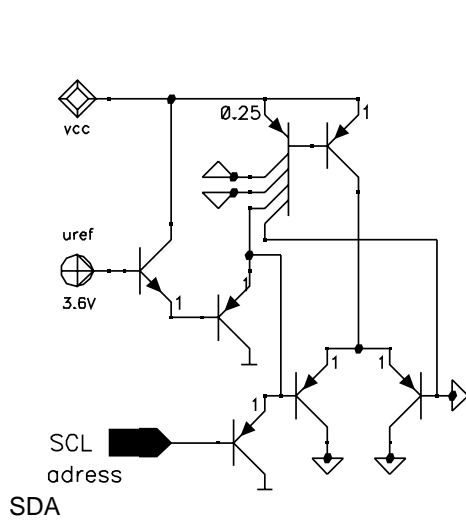

3.4 Functional Description

The main function of the IC is to switch 7 input video sources to 5 outputs.

Each output can be switched to only one input.

It is possible to have the same input connected to several outputs.

3 of the inputs can be used as non-clamping-input, switching is controlled by bus.

The clamping function of the other 4 inputs can be switched off by external resistor divider.

All switching possibilities are controlled by the I²C-BUS.

All outputs can be switched to low impedance off condition by the I²C-BUS.

Driving 75 Ω load requires external transistors.

The recommended coupling capacitor at each input is 47 nF.

Each clamping input requires a 75 Ω (max. 500 Ω) termination resistor.

Operation without or with a termination resistor greater than 500 Ω causes malfunction of the new high performance clamping circuit.

Unused input's should be directly grounded.

6 x 8 bits are necessary to determine one complete configuration change (1 addressbyte, 5 databytes).

Minimum configuration change for 1 output needs 2 x 8 bit (1 addressbyte, 1 databyte).

Power on reset state: all 5 outputs switched to input 1, all inputs clamped, Y+C off.

3.5 Block Diagram (P-DSO-28)

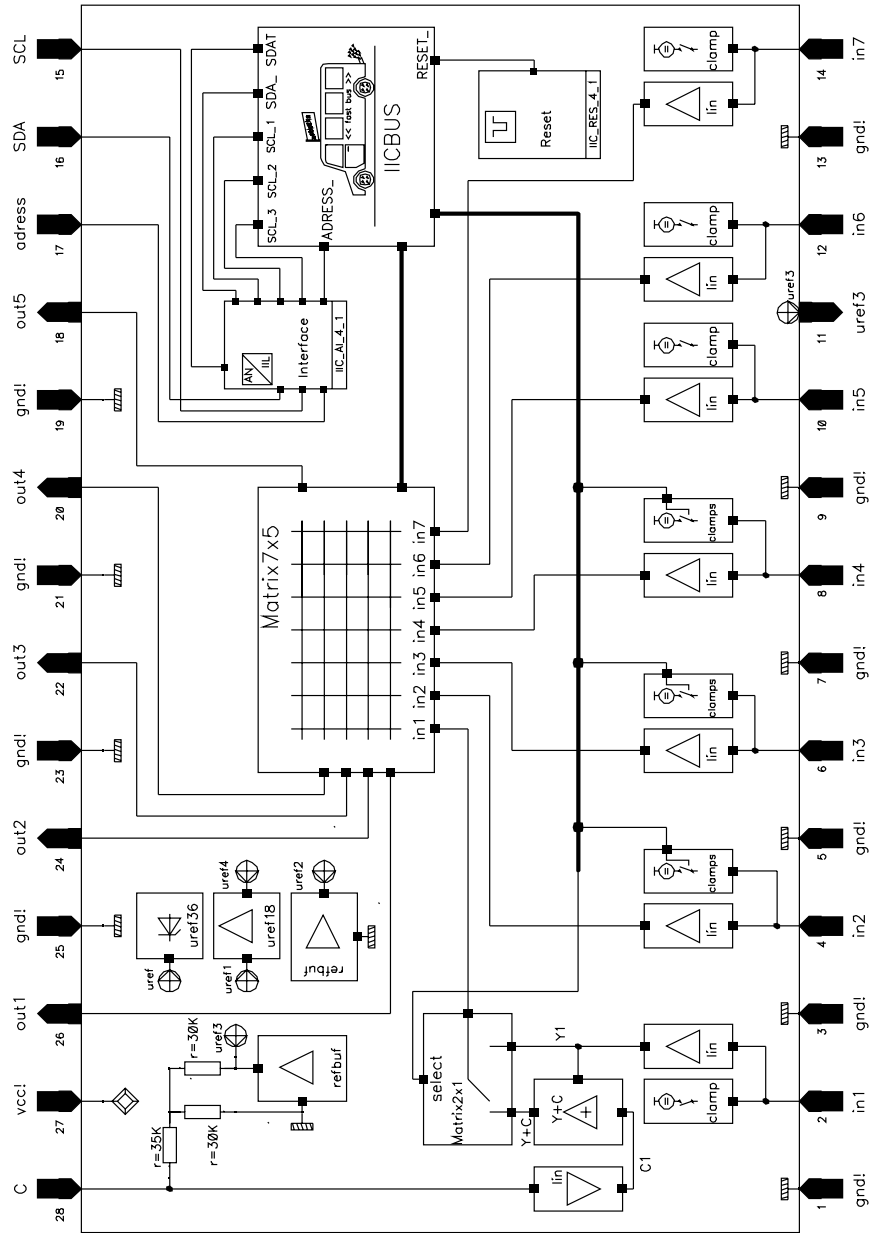

Figure 3-3 Block Diagram (P-DSO-28)

4 Applications

Contents of this Chapter

4.1	Circuits	4-2
4.1.1	Application Circuit P-DSO-28	4-2
4.1.2	Application Circuit P-DSO-28	4-3
4.1.3	Application Circuit P-DIP-18	4-4

4.1 Circuits

4.1.1 Application Circuit P-DSO-28

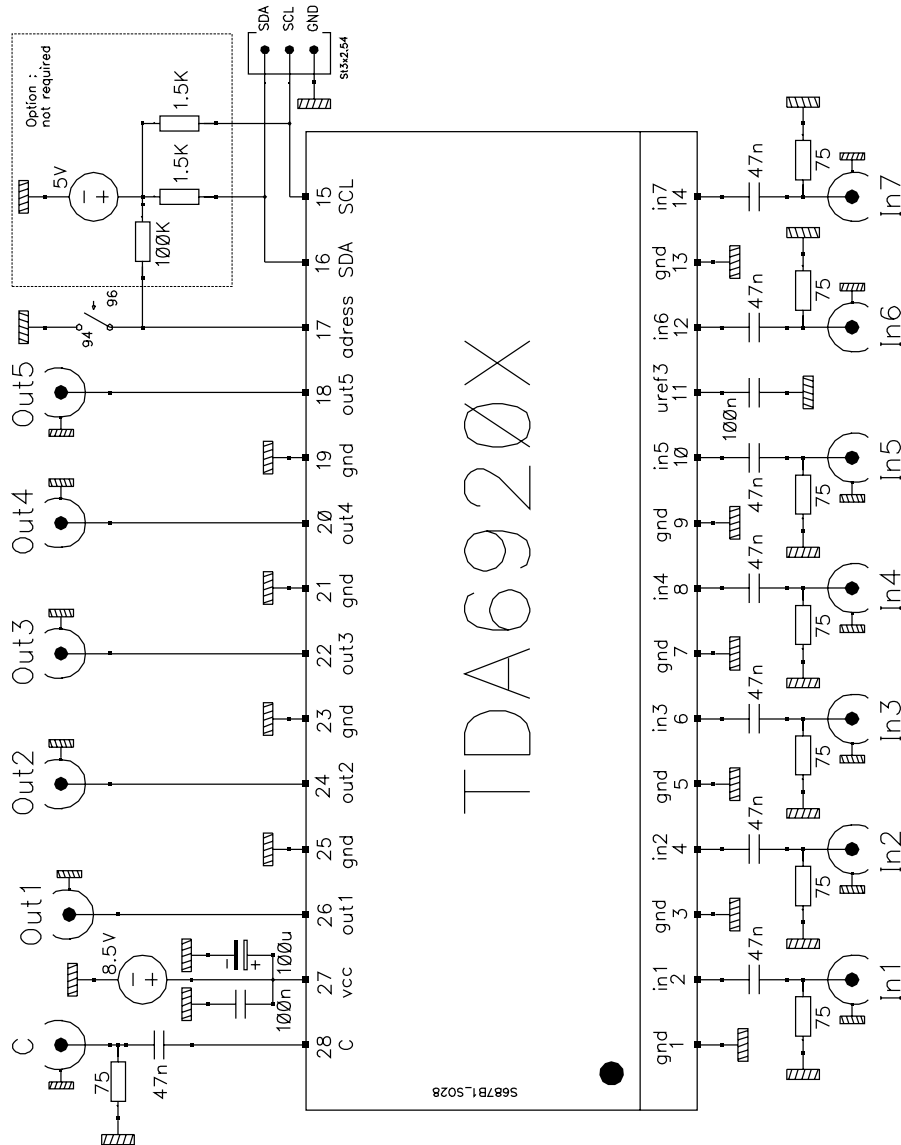

Figure 4-1 Application Circuit P-DSO-28 (clamping inputs)

4.1.2 Application Circuit P-DSO-28

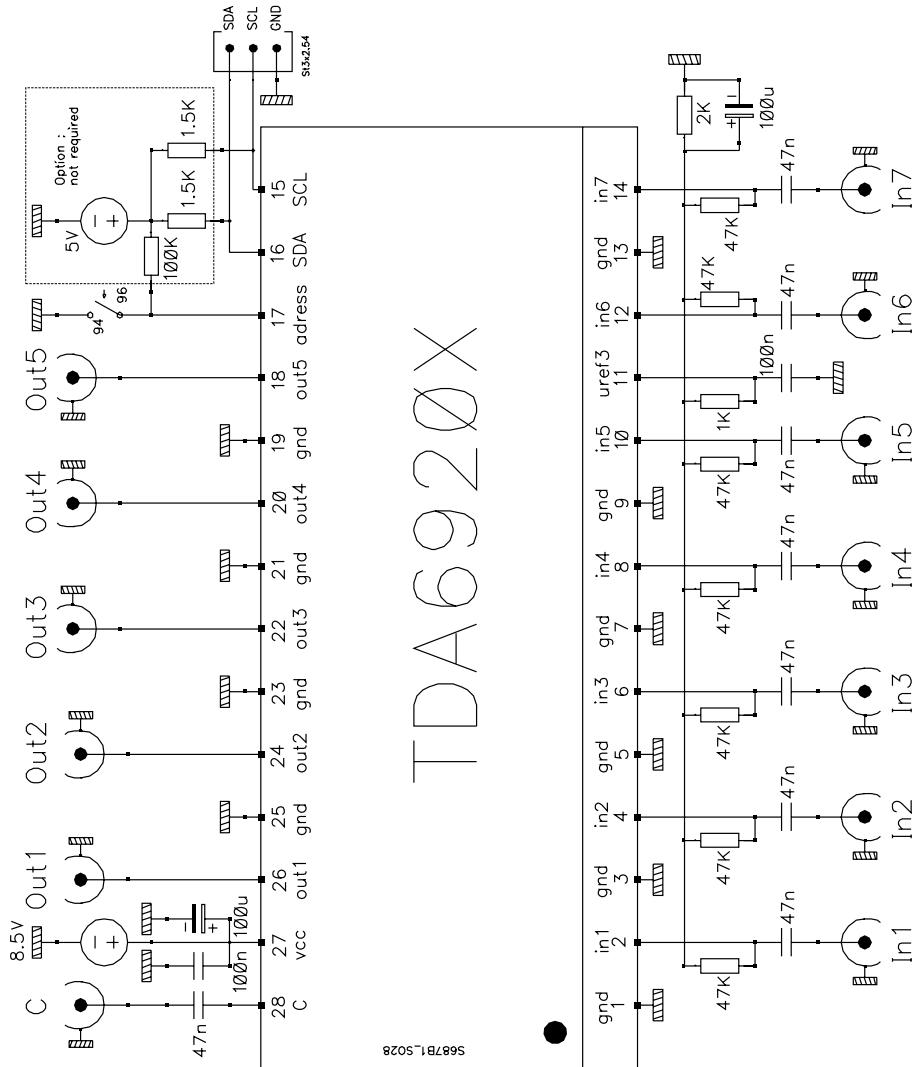

Figure 4-2 Application Circuit P-DSO-28
(no clamping inputs with clamping override)

4.1.3 Application Circuit P-DIP-18

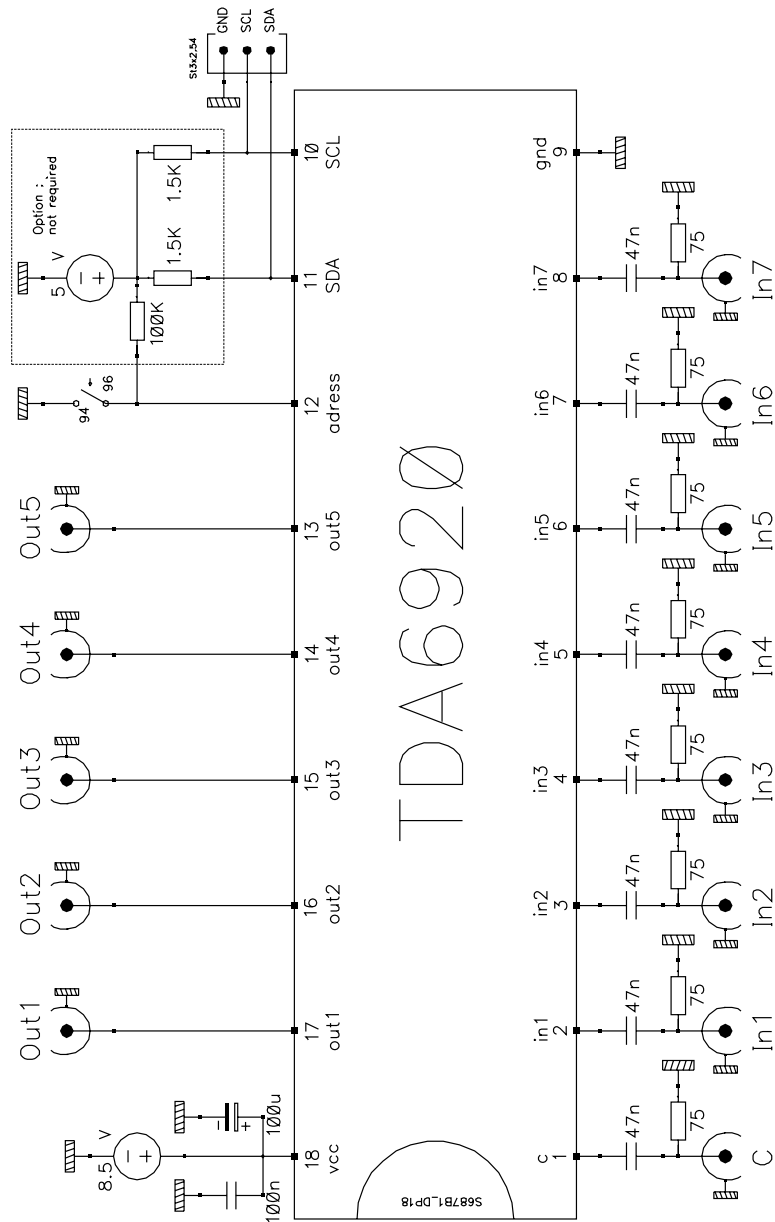

Figure 4-3 Applikation Circuit P-DIP-18

5 Reference

Contents of this Chapter

5.1	Electrical Data	5-2
5.1.1	Absolute Maximum Ratings	5-2
5.1.2	Operating Range	5-3
5.1.3	AC/DC Characteristics	5-3
5.2	Address selection (fast I2C-Bus)	5-5
5.3	Data selection (fast I2C-BUS)	5-5
5.4	Data Mode Selections (fast I2C-Bus) continued.	5-6
5.5	BUS Protocol (fast I2C-BUS)	5-6
5.6	Test Circuits	5-7
5.7	Electrical Diagramms	5-9

5.1 Electrical Data

5.1.1 Absolute Maximum Ratings



WARNING

The maximum ratings may not be exceeded under any circumstances, not even momentarily and individually, as permanent damage to the IC will result.

Table 5-1 Absolute Maximum Ratings

Parameter	Symbol	Limit Values		Unit	Remarks
		min	max		
Supply voltage (V_{cc})	V_{cc}	0	14	V	
Reference voltage (SO-28 only)	V_{ref3}	0	5	V	
Reference current ($R_{Lmin} = 1k\Omega$)	I_{ref3}		3.5	mA	
Output voltage	$V_{out1-out5}$	0	V_{cc}	V	
Output current ($R_{Lmin} = 500\Omega$)	$I_{out1-out5}$		5	mA	
Input voltage	V_C	0	V_{cc}	V	
Input voltage	$V_{In1-In7}$	0	V_{cc}	V	
SCL, SDA, address input voltage	$V_{SDA, SCL, Address}$	0	V_{cc}	V	
ESD-voltage all pins HBM ($R=1.5k\Omega$, $C=100pF$)	V_{ESD}	-6	6	kV	
Junction temperature	T_j		150	$^{\circ}C$	
Storage temperatue	T_{stg}	- 40	125	$^{\circ}C$	
Thermal resistance (system - air)	T_{thSA}		75	K/W	

All voltage values are referenced to ground, if not stated otherwise.

5.1.2 Operating Range

Within the operational range the IC operates as described in the circuit description. The AC / DC characteristic limits are not guaranteed.

Table 5-2 Operating Range							
Parameter	Symbol	Limit Values		Unit	Test Conditions	L	Item
		min	max				
Supply voltage	V_{CC}	7.5	13.2	V			
Absolute minimum supply voltage (only usable with reduced output signals of max. $2V_{pp}$)	V_{CC}	4.5		V			
Reference voltage (SO-28 only)	V_{ref3}	3.3	3.9	V			
Video-input frequency range - 3 dB	$f_{in\ In1-In7,C}$	0	20	MHz			
Video-input AC-voltage (color)	V_C		1.0	V_{pp}			
Video-input AC-voltage (Y, CVBS)	$V_{In1-In7}$		1.7	V_{pp}			
Video-output AC-voltage	$V_{out1-out5}$		3.4	V_{pp}			
Input DC-voltage	V_C	1.3	2.3	V			
Input DC-voltage (clamping)	$V_{In1-In7}$	1.8	3.5	V			
Input DC-voltage (non clamping)	$V_{In2,3,4}$	1.5	3.2	V			
Input Source-Impedance (clamping)	$R_{i\ In1-In7}$	0	500	Ω			
I ² C bus clock	$f_{in\ SDA, SCL}$	0	500	kHz			
Ambient temperature during operation	T_A	-10	85	$^{\circ}C$			

All voltage values are referenced to ground, if not stated otherwise.

5.1.3 AC/DC Characteristics

Table 5-3 AC/DC Characteristics with $T_A\ 25\ ^{\circ}C, V_{CC} = 8.5\ V$								
	Symbol	Limit Values			Unit	Test Conditions	L	Item
		min	typ	max				
Total current consumption	I_{VCC}		42	58	mA	$R_L = \infty$		
Reference voltage (SO-28 only)	V_{ref3}	3.4	3.6	3.8	V	$R_L = \infty$		
Output DC-voltage (clamping)	$V_{out1-out5}$		1.8		V	$V_{C,In1-In7} = 0\ V_{pp}$		
Output DC-voltage (output off)	$V_{out1-out5}$		0.8		V	$V_{C,In1-In7} = 0\ V_{pp}$		
Output current	$I_{out1-out5}$	0.5	1.0	2.0	mA	$V_{out} = 2V, I_n = 0\ V_{pp}$		
Input DC-voltage	V_C		1.8		V	$V_C = 0\ V_{pp}$		

Table 5-4 AC/DC Characteristics with T_A 25 °C, $V_{CC} = 8.5$ V (continued)

	Symbol	Limit Values			Unit	Test Conditions	Item
		min	typ	max			
Input DC-voltage (clamping)	$V_{In1-In7}$		1.8		V	$V_{In1-In7} = 0 V_{pp}$	
Input current (clamping)	$I_{In1-In7}$		0.33	1	μ A	$V_{In1-In7} = 0 V_{pp}$	
Input DC-voltage (for ext. clamping override)	$V_{In1-In7}$		2.4		V	$V_{In1-In7} = 0 V_{pp}$	
Input DC-voltage (non-clamping, Bus controlled)	$V_{In2,3,4}$		2.4		V	$V_{In2,3,4} = 0 V_{pp}$	
Input current (SCL, SDA, address)	$I_{SDA, SCL}$ $I_{Address}$		0.1	0.4	μ A	$V_{SDA, SCL} = 0$ V $V_{Address} = 0$ V	
Output current (SDA)	I_{SDA}	6			mA	$V_{SDA} = 0.6$ V	
Output voltage low (SDA)	V_{SDA} V_{SDA}	0 0	0.2 0.3	0.4 0.6	V V	$I_{SDA} = 3$ mA sink $I_{SDA} = 6$ mA sink	
SCL,SDA, address (96 hex) : high	$V_{SDA, SCL}$ $V_{Address}$	3.0		V_{CC}	V		
SCL,SDA, address (94 hex) : low	$V_{SDA, SCL}$ $V_{Address}$	0		1.5	V		
SCL,SDA,address (hysteresis)	$V_{SDA, SCL}$ $V_{Address}$	0.2		1	V	dependant on input frequency	
Video bandwidth	$P_{out/in}$	15	20		MHz	-3dB point	
Video gain	V_{out}/V_{in}	1.9	2.0	2.1			
Crosstalk (0 - 5 MHz) SO-28	A		-65	-60	dB	inputs 75 Ω to gnd	
Crosstalk (0 - 5 MHz) SO-28	A		-55	-50	dB	inputs 500 Ω to gnd	
Crosstalk (0 - 5 MHz) DIP-18	A		-62	-57	dB	inputs 75 Ω to gnd	
Crosstalk (0 - 5 MHz) DIP-18	A		-45	-40	dB	inputs 500 Ω to gnd	
Input AC-voltage	V_C		0.75	1	V_{pp}	sinus	
Input AC-voltage	$V_{In1-In7}$		1	1.5	V_{pp}	clamped	
Input AC-voltage (sinus)	$V_{In2,3,4}$		1	1.5	V_{pp}	non clamped	
Output AC-voltage	$V_{out1-out5}$		2	3	V_{pp}		
I ² C bus clock	f_{in} SDA, SCL		400	500	kHz		
Output linearity	$DG_{out1-out5}$		0.2	1	%	$R_L = \infty$	
Input resistance (non-clamping)	$R_{C,In2,3,4}$	40	50		k Ω		
Input Source-Impedance (clamping)	$R_{In1-In7}$	0	75	500	Ω		
Input Coupling-Capacitor (clamping)	$C_{In1-In7}$		47 10		nF μ F	CVBS-signal >20Hz Audiosignal	
Output dyn. impedance	$R_{out1-out5}$		50	75	Ω		

5.2 Address selection (fast I²C-Bus)

1st byte of transmission (8 bit)

Table 5-5			
HEX	binary		address pin
	MSB	LSB	
9 6	1 0 0 1	0 1 1 0	VCC (min. 3V)
9 4	1 0 0 1	0 1 0 0	GND

5.3 Data selection (fast I²C-BUS)

2nd byte of transmission (8 bit)

Table 5-6 Output selection (3bit, 7bit must always be 0)			
b7 b6*	b5 b4 b3	b2 b1 b0*	selected output
0 x	0 0 0	x x x	- not used
0 x	0 0 1	x x x	out1
0 x	0 1 0	x x x	out2
0 x	0 1 1	x x x	out3
0 x	1 0 0	x x x	out4
0 x	1 0 1	x x x	out5
0 x	1 1 0	x x x	- not used
0 x	1 1 1	x x x	- not used

* X = don't care

Table 5-7 Input selection clamped (3 bit, bit7 must always be 0)			
b7 b6	b5 b4 b3*	b2 b1 b0	selected output
0 x	x x x	0 0 0	output off condition
0 0	x x x	0 0 1	in1
0 0	x x x	0 1 0	in2
0 0	x x x	0 1 1	in3
0 0	x x x	1 0 0	in4
0 x	x x x	1 0 1	in5
0 x	x x x	1 1 0	in6
0 x	x x x	1 1 1	in7

* X = don't care

5.4 Data Mode Selections (fast I2C-Bus) continued

2nd byte of transmission (8 bit)

Table 5-8 Input selection non clamped / Y+C (Y:always clamped; C:non clamped) ; (3 bit, bit 7 should always be 0)			
b7 b6	b5 b4 b3*	b2 b1 b0	selected input
0 0	x x x	0 0 1	in1, (Y+C) off
0 0	x x x	0 1 0	in2, clamp on
0 0	x x x	0 1 1	in3, clamp on
0 0	x x x	1 0 0	in4, clamp on
0 1	x x x	0 0 1	in1, (Y+C) on
0 1	x x x	0 1 0	in2, clamp off
0 1	x x x	0 1 1	in3, clamp off
0 1	x x x	1 0 0	in4, clamp off

*X = don' t care (if only input operation mode change is requested, b5, b4, b3 should be 0, 0, 0 : no output configuration is changed.)

5.5 BUS Protocol (fast I²C-BUS)

Programming Example : SDA sequence

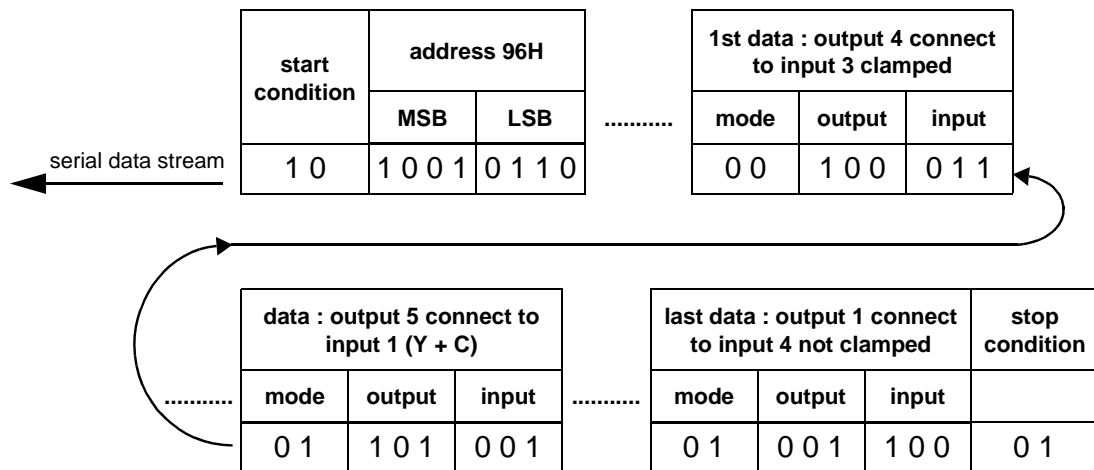

5.6 Test Circuits

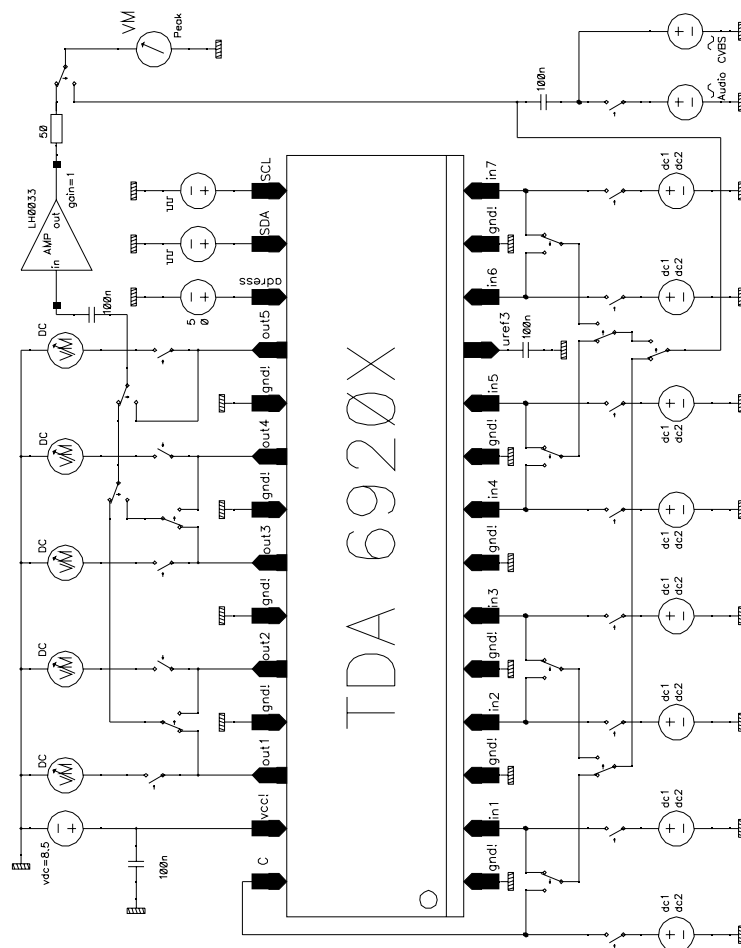

Figure 5-1 Test circuit P-DSO-28

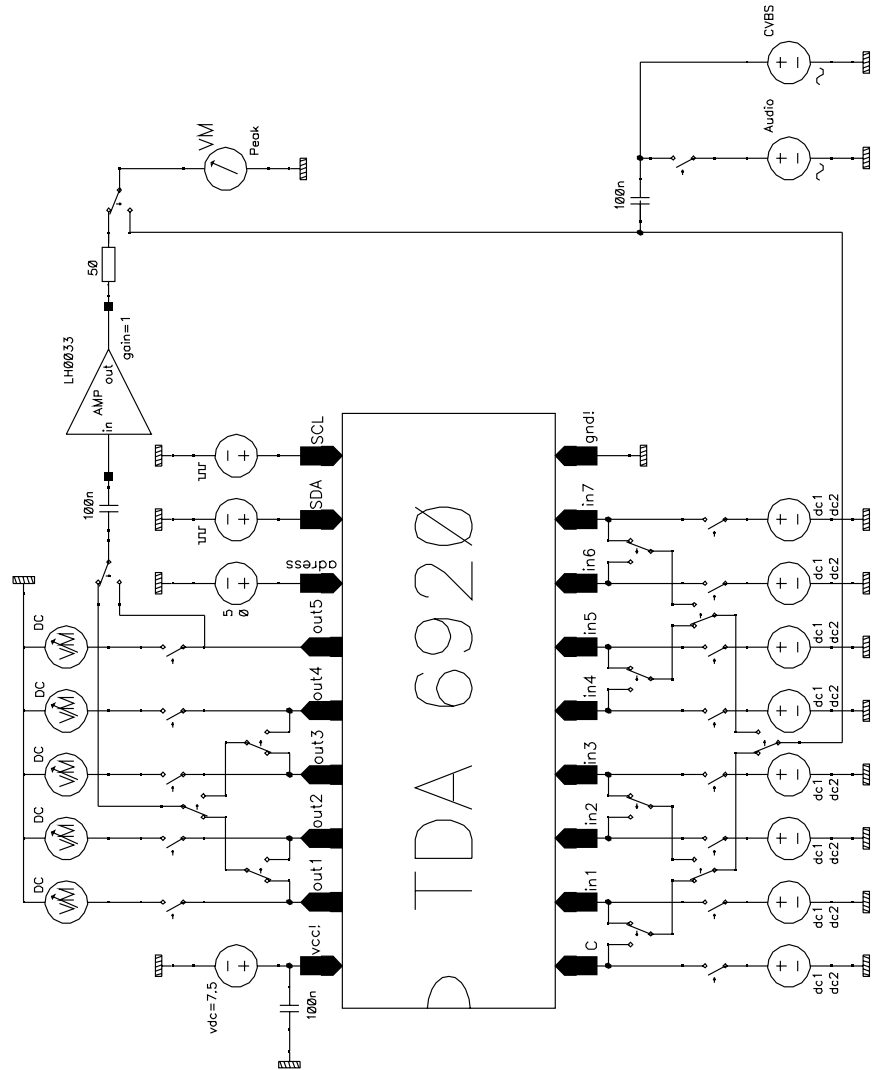
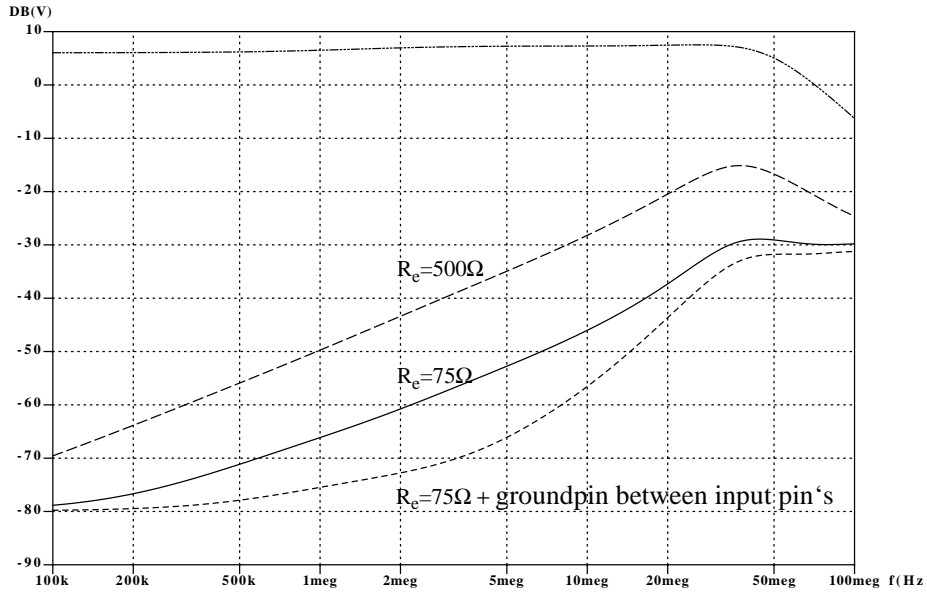

Figure 5-2 Test circuit P-DIP-18

5.7 Electrical Diagramms

Typical frequency response and crosstalk (simulated) for P-DSO-28 package



- Conditions: $V_{CC} = 8.5V$, all outputs selected to one different input;
 response: the measured output has max. signal on the selected input;
 crosstalk : the measured output has no signal on the selected input, another input has max. signal.