

**SIEMENS**

SIEMENS AKTIENGESELLSCHAFT

T-77-07-07

**TV-Stereo Processor****TDA 6610-2****Bipolar IC****Features**

- All functions are I<sup>2</sup>C-bus controlled
- Suitable for multistandard including NICAM SCART-interface
- Independent headphones output high signal noise ratio
- Extremely low total harmonic distortion
- High security of detection of the stereo decoder part because of the digital interference suppression and the very narrow bandwidth

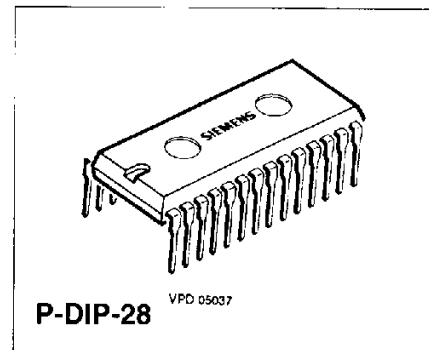

Type	Ordering Code	Package
TDA 6610-2	Q67000-A5026	P-DIP-28

**General**

The TDA 6610-2 represents a complete TV-stereo sound system controlled via the I<sup>2</sup>C-bus. The IC is divided into three functional blocks:

1. **Stereo Sound Processing with High Quality (exceeds DIN 45500; suitable for NICAM and CD)**
  - a) Matrix for G-standard
  - b) Additional single-channel AF-input (for e.g. AF-signal according to L-standard)
  - c) Stereo SCART-interface is in accordance with FTZ-official specification
  - d) Stereo loudspeaker signal section with Ch1/Ch2 switch, treble/bass control, quasi-stereo/ stereo base width control and separate left/right loudspeaker volume control
  - e) Signal section with Ch1/Ch2 switch and volume control for stereo headphones

---

**SIEMENS AKTIENGESELLSCHAFT**

---

**2. TV-Sound Identification Signal Decoder Consisting of:**

- a) Active pilot signal filter
- b) Phase-independent rectifier with very narrow bandwidth for evaluation of the identification signal
- c) Digital integrator to reduce interference
- d) Multiplexer for cyclical switch over between "stereo" or "dual" recognition
- e) PLL for the generation of the reference signal. External synchronization with either the fly-back pulse or external reference clock signals of 62.5 kHz

**3. Control Section for:**

- a) I<sup>2</sup>C-bus interface with listen/talk function
- b) Control of the complete AF-sound processing
- c) Control of the identification signal decoder
- d) Reading of the identification signal decoder status
- e) Test modes

## SIEMENS AKTIENGESELLSCHAFT

## Pin Functions

Pin No.	Function
1	AF-input mono, left, sound 1
2	Bias for AF-unit
3	AF-input right, sound 2
4	54-kHz input
5	54-kHz filter
6	AF-input (L-standard)
7	AF-input SCART left (sound 1)
8	AF-input SCART right (sound 2)
9	AF-output SCART (mono, sound 1, left)
10	AF-output SCART (mono, sound 2, right)
11	Phase-shifter quasi-stereo
12	Phase-shifter quasi-stereo
13	Cutoff frequency base (base-width) left
14	Cutoff frequency base (base-width) right
15	AF-output, loudspeaker left
16	AF-output, loudspeaker right
17	Cutoff frequency treble left
18	Cutoff frequency treble right
19	AF-output, headphones left
20	AF-output, headphones right
21	+ $V_S$ (supply voltage)
22	I <sup>2</sup> C-bus SCL
23	I <sup>2</sup> C-bus SDA
24	Input H-pulse (4 x H-pulse)
25	Filter ID-signal decoder
26	Filter ID-signal decoder
27	PLL-filter ID-signal decoder
28	Ground

SIEMENS AKTIENGESELLSCHAFT

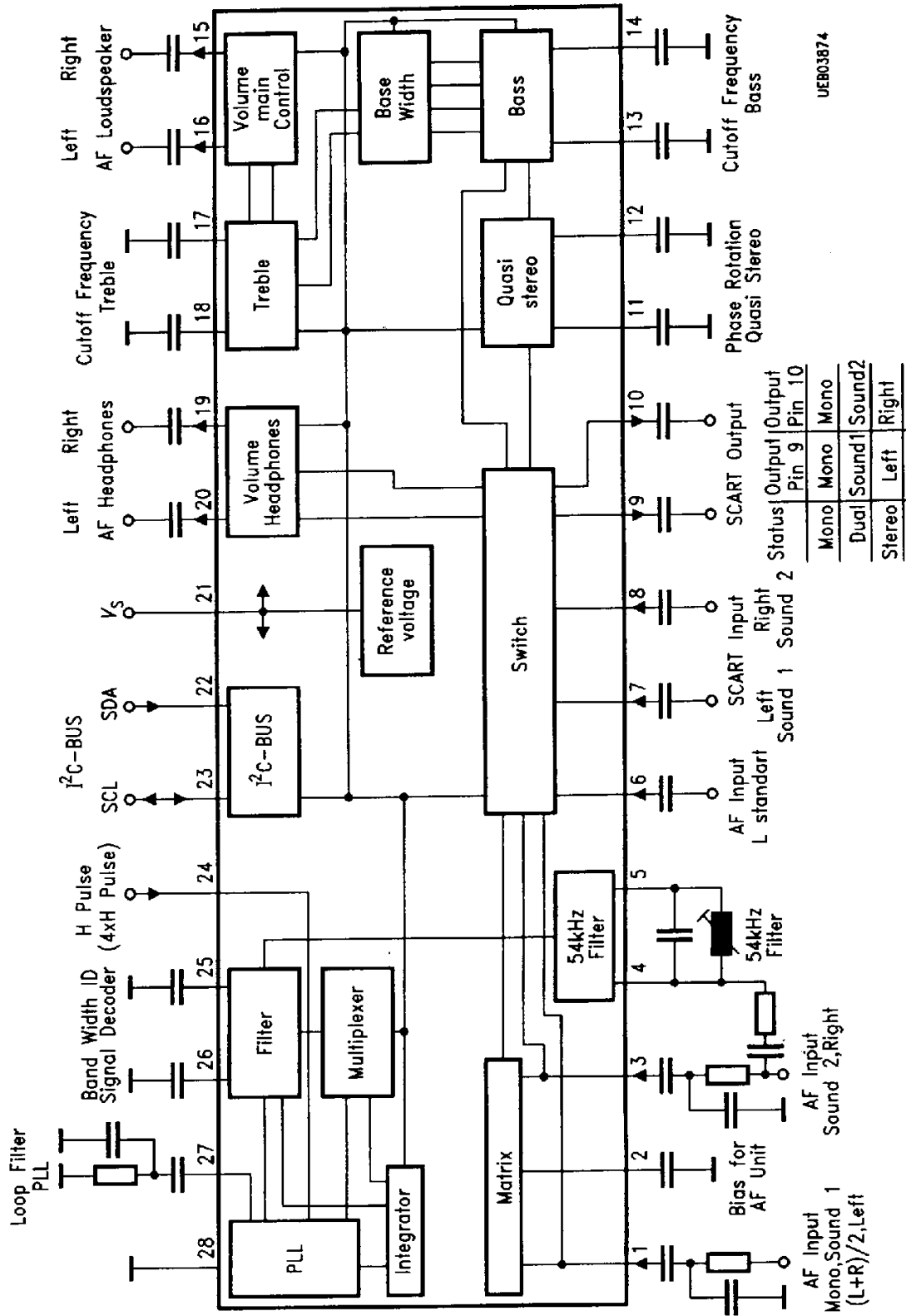

Block Diagram

**SIEMENS AKTIENGESELLSCHAFT****Circuit Description****Signal Section**

The audio signal processing in the matrix and the switch-over for multichannel TV-sound signals according to the two-carrier system used in Germany takes place in the matrix and switching sections. In addition to the two inputs for the demodulated sound carrier a two-channel SCART-input and an additional mono input (e.g. for demodulated L-standard sound) are provided. The two AF-inputs can be by-passed internally in such a way that decoded stereo sound signals of other audio systems (NICAM) can be processed. The switching section is terminated with the SCART-output and an independently switchable Ch1/Ch2 switch for the loudspeaker and headphone outputs.

In the loudspeaker signal path a switchable quasi-stereo section follows the Ch1/Ch2 switch. This section gives a special audio effect with mono signals due to a 180° phase shift at medium frequencies (about 1 kHz) in one channel. The following bass control exhibits a step of 3 dB with an adjustment range of + 15/- 12 dB. The cutoff frequency is set for each channel with an external capacitor.

A circuit for stereo base-width expansion, switchable if stereo signals are recognized, provides a more spatial audio effect due to 50 % of frequency dependent crosstalk in opposing phases. The circuit operates with the same cutoff frequency as the bass control, but the function is largely independent. Likewise the treble control, whose cutoff frequency is also controlled by a capacitor in each channel, has a step of 3 dB with an adjustment range of ± 12 dB. The volume control can be adjusted independently for the right and left loudspeaker signal path. Using 57 steps of 1.25 dB each, a 70 dB adjustment range is available, where the 57th step activates the "MUTE" function. Functions such as "balance" or "loudness" are realized by software adjustment of the appropriate tone and volume controls.

In the signal path for the headphones after the Ch1/Ch2 switch a volume control circuit is used for the simultaneous left/right adjustment. Thirty-two steps of 2 dB each allow an adjustment range of 62 dB (31 x 2 dB = 62 dB, while the 32nd step activates the "MUTE" function).

**Identification Sound Decoder**

The input of the identification sound decoder consists of an op-amp for the pilot signal with its sidebands. An external LC-circuit is used to select the pilot carrier and his sidebands. The signal is then passed to a phase-independent active band-pass filter with a very narrow bandwidth (adjustable externally). This filter detects whether the lower side-band of the pilot carrier, modulated with the identification signal, is present. The center frequency of the filter is switched between "dual" and "stereo" by a multiplexer. The multiplexing frequency is adjustable by software. If a side-band is detected, the multiplexer stops. The first "detected" criterion is processed by a digital integrator and a following comparator in order to suppress interferences due to noise. The decoder status can be read out via I<sup>2</sup>C-bus (talk mode) as the "stereo" or "dual" mode. The control of the corresponding signal path can take place either directly internally or through the  $\mu$ C. All required clock signals are derived from a fast locking PLL synchronized by an external reference frequency. This reference frequency has to be sufficiently close to the horizontal frequency, but **a rigid phase coupling is not required**. Therefore, alternatively to the line frequency the use of a crystal-controlled 62.5 kHz frequency commonly available in PLL tuning systems is possible.

– SIEMENS AKTIENGESELLSCHAFT

**Control Section**

All functions are controlled via I<sup>2</sup>C-bus interface with listen/talk functions. The actual valid data are stored in a latch block.

The telegram structure is:

start condition - chip address - any number of data bytes - stop condition

The following conditions apply to the data bytes:

Before a data byte (with the adjustment information) is transmitted, a subaddress byte has **always** to be transmitted.

Example: The headphone volume (HP vol) has to be increased in several (i.e. 3) steps.

Right		Wrong	
Start condition		Start condition	
Chip address	84 (Hex)	Chip address	84 (Hex)
Subaddr. vol	03 (Hex)	Subaddr. vol	03 (Hex)
Volume step 8	08 (Hex)	Volume step 8	08 (Hex)
Subaddr. vol	03 (Hex)	Volume step 9	09 (Hex)
Volume step 9	09 (Hex)	Volume step 10	0A (Hex)
Subaddr. vol	03 (Hex)	Stop condition	
Volume step 10	0A (Hex)		
Stop condition			

Within a telegram (i.e. without a new start condition) any different subaddresses can be accessed. The changeover between "listen" and "talk" however has always to be initialized via the sequence "stop condition - start condition - chip address". Before each readout always a start condition and chip address (talk) has to be transmitted. The data to be read out are loaded into the I<sup>2</sup>C-bus interface after this sequence and are available for the transfer to the  $\mu$ C.

**Chip Address**

MSB	•	•	•	•	•	•	LSB
1	0	0	0	0	1	0	R/W

R/W = 0 → Read (Listen)

R/W = 1 → Write (Talk)

SIEMENS AKTIENGESELLSCHAFT

**Subaddress Bytes**

	MSB	•	•	•	•	•	•	LSB
Loudspeaker volume left	X	X	X	X	X	0	0	1
Loudspeaker volume right	X	X	X	X	X	0	1	0
Headphone volume	X	X	X	X	X	0	1	1
Treble/bass	X	X	X	X	X	1	0	1
Switch byte I	X	X	X	X	X	1	1	1
Switch byte II	X	X	X	X	X	0	0	0

**Setting Bytes**

**a) Loudspeaker Volume Left / Right**

	MSB	•	•	•	•	•	•	LSB
Maximum volume	X	X	1	1	1	1	1	1
Max – 1 step	X	X	1	1	1	1	1	0
Max – 15 steps	X	X	1	1	0	0	0	0
Max – 55 steps	X	X	0	0	1	0	0	0
MUTE	X	X	0	0	0	1	1	1
MUTE	X	X	0	0	0	0	0	0
MUTE	X	X	0	0	0	X	X	X
Power ON	0	0	0	0	0	0	0	1

**b) Headphone Volume**

	MSB	•	•	•	•	•	•	LSB
Max. volume	T2	T1	T0	1	1	1	1	1
Max – 1 step	T2	T1	T0	1	1	1	1	0
Max – 15 steps	T2	T1	T0	1	0	0	0	0
Max – 31 steps	T2	T1	T0	0	0	0	0	1
MUTE	T2	T1	T0	0	0	0	0	0
Power ON	0	0	0	0	0	0	0	1

T0 - T2 are test bits; these have to be set to 0 for normal operation.

**SIEMENS**

TDA 6610-2

## SIEMENS AKTIENGESELLSCHAFT

## c) Treble / Bass

	MSB	•	•	•	•	•	•	LSB
Linear	1	0	0	0	1	0	0	0
Max. treble, lin. bass	1	1	0	0	1	0	0	0
Max. treble, lin. bass	1	1	X	X	1	0	0	0
Min. treble, lin. bass	0	1	0	0	1	0	0	0
Min. treble, lin. bass	0	0	X	X	1	0	0	0
Lin. treble, max. bass	1	0	0	0	1	1	0	1
Lin. treble, max. bass	1	0	0	0	1	1	X	1
Lin. treble, max. bass	1	0	0	0	1	1	1	X
Lin. treble, min. bass	1	0	0	0	0	1	0	0
Lin. treble, min. bass	1	0	0	0	0	0	X	X
Max. treble, max. bass	1	1	X	X	1	1	X	1
Min. treble, min. bass	0	0	X	X	0	0	X	X
Power ON	0	0	0	0	0	0	0	1
	MSB				LSB	MSB		LSB
	treble				treble	bass		bass



SIEMENS AKTIENGESELLSCHAFT

**d) Switch Byte I**

MSB	.	.	.	.	.	.	LSB
MUTE I	MUTE II	Ch1/Ch2 <sub>vol</sub>	Ch1/Ch2 <sub>HP</sub>	Mono	SCART	SCART-D	AM
MUTE I = 0		All AF-outputs are muted (loudspeakers, headphones, SCART); power ON					
MUTE I = 1		All AF-outputs ON					
MUTE II = 0		Loudspeaker outputs muted; power ON					
MUTE II = 1		Loudspeaker outputs ON					
MUTE I and MUTE II are OR gated with respect to the loudspeaker outputs							

MUTE I	MUTE II	Loudspeaker outputs	Headphones, SCART-outputs
0	0	muted	muted
0	1	muted	muted
1	0	muted	ON
1	1	ON	ON

CH1/Ch2<sub>vol</sub> = 0 Sound 1 on the loudspeaker outputs; power ON

CH1/Ch2<sub>vol</sub> = 1 Sound 2 on the loudspeaker outputs

CH1/Ch2<sub>HP</sub> = 0 Sound 1 on the headphone outputs; power ON

CH1/Ch2<sub>HP</sub> = 1 Sound 2 on the headphone outputs

CH1/Ch2<sub>vol</sub> and CH1/Ch2<sub>HP</sub> are only effective if the matrix is set to the position "dual sound".

Mono = 0 identification signal decoder is set to mono position and held; power ON

Mono = 1 normal operation of identification signal decoder

SCART = 0 normal TV-operation; power ON

SCART = 1 SCART-playback; connection of SCART-inputs - AF-outputs. SCART = 1 has priority over AM = 1 (loudspeaker and headphones)

SCART-D = 0 SCART-playback stereo (mono); power ON

SCART-D = 1 Enable for the Ch1/Ch2 switch during SCART-playback (only effective when SCART = 1)

Standard L = 0 normal operation (G-standard)

Standard L = 1 AM AF-input is activated; power ON

AM = 1 has priority over bypass = 1

SIEMENS AKTIENGESELLSCHAFT

**e) Switch Byte II**

MSB							LSB
MPX0	MPX1	Quasi-st	Be	H-pul	Matrix 0	Matrix 1	Bypass
MPX0	MPX 1	MPX period					recommended $C_{25, 26}$
0	0	2 s		power ON			1 $\mu$ F
0	1	4 s					2.2 $\mu$ F
1	0	8 s					4.7 $\mu$ F
1	1	1 s					470 nF

MPX-period = 2 s signifies: Identification (ID) signal decoder searches 1 s for dual and 1 s for stereo transmission

- Quasi-st = 0 Quasi-stereo OFF; Power ON
- Quasi-St = 1 Quasi-stereo ON
- Be = 0 Stereo basewidth expansion OFF; Power ON
- Be = 1 Stereo basewidth expansion ON

- H pul = 0 ID-signal decoder synchronization with  $f_H = 15.625$  kHz; power ON
- H pul = 1 ID-synchronization with  $4 \times f_H$

- |          |          |  |
|----------|----------|--|
| Matrix 0 | Matrix 1 | Matrix status                            |
| 0        | 0        | mono power ON                            |
| 0        | 1        | stereo                                   |
| 1        | 0        | dual                                     |
| 1        | 1        | automatic according to ID-signal decoder |

- Bypass = 0 Normal operations (G-standard)
- Bypass = 1 Matrix is bridged so that left/right signals can be fed in; power ON (AM = 1 has priority over bypass = 1)

**SIEMENS AKTIENGESELLSCHAFT****Priority List of Setting Bits**

1. MUTE I
2. MUTE II (only with regard to the loudspeaker outputs)
3. SCART
4. Standard L
5. Bypass
6. Matrix 0, 1

**h) Talk Mode**

MSB	•	•	•	•	•	•	LSB
St	D	T5	T4	T3	X	X	X
0	0	decoder detects mono					
1	0	decoder detects stereo					
0	1	decoder detects dual					
1	1	internally inhibited					

T3 - T5 are test bits

SIEMENS AKTIENGESELLSCHAFT

**Absolute Maximum Ratings**

$T_A = 0$  to  $70$  °C; all voltages relatives to  $V_{SS}$

Parameter	Symbol	Limit Values		Unit	Remarks
		min.	max.		
Supply voltage	$V_{21}$	0	14	V	
Max. DC-voltage	$V_1$	0	$V_{21}$	V	
Max. DC-voltage	$V_2$	0	$V_{21}$	V	
Max. DC-voltage	$V_3$	0	$V_{21}$	V	
Max. DC-voltage	$V_4$	0	$V_{21}$	V	
Max. DC-voltage	$V_6$	0	$V_{21}$	V	
Max. DC-voltage	$V_7$	0	$V_{21}$	V	
Max. DC-voltage	$V_8$	0	$V_{21}$	V	
Max. DC-voltage	$V_{11}$	0	$V_{21}$	V	
Max. DC-voltage	$V_{12}$	0	$V_{21}$	V	
Max. DC-voltage	$V_{13}$	0	$V_{21}$	V	
Max. DC-voltage	$V_{14}$	0	$V_{21}$	V	
Max. DC-voltage	$V_{17}$	0	$V_{21}$	V	
Max. DC-voltage	$V_{18}$	0	$V_{21}$	V	
Max. DC-voltage	$V_{22}$	0	$V_{21}$	V	
Max. DC-voltage	$V_{23}$	0	$V_{21}$	V	
Max. DC-voltage	$V_{24}$	0	$V_{21}$	V	
Max. DC-voltage	$V_{25}$	0	$V_{21}$	V	
Max. DC-voltage	$V_{26}$	0	$V_{21}$	V	
Max. DC-current	$I_5$	0	2	mA	
Max. DC-current	$I_9$	0	2	mA	
Max. DC-current	$I_{10}$	0	2	mA	
Max. DC-current	$I_{15}$	0	2	mA	
Max. DC-current	$I_{16}$	0	2	mA	
Max. DC-current	$I_{19}$	0	2	mA	
Max. DC-current	$I_{20}$	0	2	mA	
Max. DC-current	$I_{27}$	0	1	mA	
Junction temperature	$T_j$		150	°C	
Storage temperature	$T_{stg}$	- 40	125	°C	
Thermal resistance system ambient	$R_{th SA}$		53	K/W	

**Operating Range**

Supply voltage	$V_6$	10	13.2	V	
Ambient temperature	$T_A$	0	70	°C	
Input frequency range	$f_i$	0.01	20	kHz	

**Characteristics**

$V_S = 12\text{ V}$ ;  $T_A = 25\text{ °C}$ , in accordance with test circuit 1

I<sup>2</sup>C-bus present: start - 84 - 01,3F - 0 2,3F - 0 3,1F - 0 5,88 - 0 6,10 - 07,C8 - 00,01 - stop

Chip address - Vol<sub>LSI</sub> 63 - Vol<sub>LSr</sub> 63 - Vol<sub>HP</sub> 31 - tone lin - adj 0dB - MUTE I, MUTE II, Mono - Bypass

The basic setting for each point in the specification is always preset; only settings which deviate from this are given in the test conditions. Details in *italics* only provide explanation of the hexadecimal code and with switch bits on the set bits and features are stated.

Parameter	Symbol	Limit Values			Unit	Test Condition
		min.	typ.	max.		
Current consumption	$I_{21}$		50		mA	

**Signal Section**

Max. gain	$V_{16-1}$	-2	0	2	dB	
Max. gain	$V_{15-3}$	-2	0	2	dB	
Max. gain	$V_{20-1}$	-2	0	2	dB	
Max. gain	$V_{19-3}$	-2	0	2	dB	
Max. gain	$V_{16-3}$	-2	0	2	dB	00,02; $V_1 = 01$ <i>Matrix: Stereo</i>
Max. gain	$V_{15-3}$	-2	0	2	dB	00,02; $V_1 = 01$ <i>Matrix: Stereo</i>
Max. gain	$V_{20-3}$	-2	0	2	dB	00,02; $V_1 = 0$ <i>Matrix: Stereo</i>
Max. gain	$V_{19-3}$	-2	0	2	dB	00,02; $V_1 = 0$ <i>Matrix: Stereo</i>
Max. gain	$V_{16-1}$	4	6	8	dB	00,02; $V_3 = 0$ <i>Matrix: Stereo</i>
Max. gain	$V_{20-1}$	4	6	8	dB	00,02; $V_3 = 0$ <i>Matrix: Stereo</i>
Max. gain	$V_{16-7}$	-5	-3	-1	dB	07,CC, SCART
Max. gain	$V_{15-8}$	-5	-3	-1	dB	07,CC, SCART
Max. gain	$V_{20-7}$	-5	-3	-1	dB	07,CC, SCART
Max. gain	$V_{19-8}$	-5	-3	-1	dB	07,CC, SCART
Max. gain	$V_{16-6}$	-2	0	2	dB	07,C9, Standard L
Max. gain	$V_{15-6}$	-2	0	2	dB	07,C9, Standard L
Max. gain	$V_{20-6}$	-2	0	2	dB	07,C9, Standard L
Max. gain	$V_{19-6}$	-2	0	2	dB	07,C9, Standard L

## Characteristics (cont'd)

 $V_S = 12\text{ V}$ ;  $T_A = 25\text{ }^\circ\text{C}$ , in accordance with test circuit 1

Parameter	Symbol	Limit Values			Unit	Test Condition
		min.	typ.	max.		
Gain	$V_{9-1}$	-2	0	2	dB	
Gain	$V_{10-3}$	-2	0	2	dB	
Gain	$V_{9-3}$	-2	0	2	dB	00,02; $V_1 = 0$ Matrix: Stereo
Gain	$V_{10-3}$	-2	0	2	dB	00,02; $V_1 = 0$ Matrix: Stereo
Gain	$V_{9-1}$	4	6	8	dB	00,02; $V_3 = 0$ Matrix: Stereo
Gain	$V_{10-6}$	-2	0	2	dB	07,C9 Standard L
Gain	$V_{9-6}$	-2	0	2	dB	07,C9 Standard L
Min. gain	$V_{16-1}$	-65	-70		dB	01,08-02,08 $Vol_{LSI} 8-Vol_{LSr} 8$
Min. gain	$V_{15-3}$	-65	-70		dB	01,08-02,08 $Vol_{LSI} 8-Vol_{LSr} 8$
Min. gain	$V_{20-1}$	-57	-62		dB	03,01 $Vol_{HP} 1$
Min. gain	$V_{19-3}$	-57	-62		dB	03,01 $Vol_{HP} 1$
Min. gain	$V_{16-7}$	-68	-73		dB	07,CC-01,08-02,08 SCART- $Vol_{LSI} 8-Vol_{LSr} 8$
Min. gain	$V_{15-8}$	-68	-73		dB	07,CC-01,08-02,08 SCART- $Vol_{LSI} 8-Vol_{LSr} 8$
Min. gain	$V_{20-7}$	-60	-65		dB	07,CC-03,01 SCART- $Vol_{KH} 1$
Min. gain	$V_{19-8}$	-60	-65		dB	07,CC-03,01 SCART- $Vol_{KH} 1$
Min. gain	$V_{16-6}$	-60	-70		dB	07,C9-01,08-02,08 Standard L $Vol_{LSI} 8-Vol_{LSr} 8$
Min. gain	$V_{15-6}$	-60	-70		dB	07,C9-01,08-02,08 Standard L $Vol_{LSI} 8-Vol_{LSr} 8$
Min. gain	$V_{20-6}$	-57	-62		dB	07,C9-03,01 Standard L $Vol_{KH} 1$
Min. gain	$V_{19-6}$	-57	-62		dB	07,C9-03,01 Standard L $Vol_{KH} 1$
Flutter and wow	$\Delta V_{15-16}$			$\pm 2$	dB	01,3F to 01,24 02,3F to 02,24 $Vol_{LSI} 63-36-Vol_{LSr} 63-36$
Flutter and wow	$\Delta V_{19-20}$			$\pm 2$	dB	03,1F to 03,13 $Vol_{KH} 31-19$

SIEMENS AKTIENGESELLSCHAFT

**Characteristics (cont'd)**

$V_S = 12\text{ V}$ ;  $T_A = 25\text{ °C}$ , in accordance with test circuit 1

Parameter	Symbol	Limit Values			Unit	Test Condition
		min.	typ.	max.		
Step width Vol <sub>15</sub>	$\Delta V_{15}$	0	1.25	2.5	dB	01,X-01, (X ± 1) Vol <sub>LSI</sub> X-Vol <sub>LSI</sub> (X ± 1)
Step width Vol <sub>16</sub>	$\Delta V_{16}$	0	1.25	2.5	dB	02,X-02,(X±1) Vol <sub>LSr</sub> X-Vol <sub>LSr</sub> (X ± 1)
Step width Vol <sub>19</sub>	$\Delta V_{19}$	0	2	4	dB	03,X-03, (X ± 1) Vol <sub>KH</sub> X-Vol <sub>KH</sub> (X ± 1)
Step width Vol <sub>20</sub>	$\Delta V_{20}$	0	2	4	dB	03,X-03, (X ± 1) Vol <sub>KH</sub> X-Vol <sub>KH</sub> (X ± 1)
Bass boost	$V_{16-1}$	13	15		dB	05,8F; $f_1 = 40\text{ Hz}$ Bass max, treble lin.
Bass boost	$V_{15-3}$	13	15		dB	05,8F; $f_1 = 40\text{ Hz}$ Bass max, treble lin.
Bass boost	$V_{16-1}$	- 10	- 12		dB	05,8F; $f_1 = 40\text{ Hz}$ Bass max, treble lin.
Bass boost	$V_{15-3}$	- 10	- 12		dB	05,8F; $f_1 = 40\text{ Hz}$ Bass max, treble lin.
Step wide bass	$\Delta V_{15}$	1	3	5	dB	05,8X-05,8 (X ± 1) Bass X - bass (X ± 1)
Step wide bass	$\Delta V_{16}$	1	3	5	dB	05,8X-05,8 (X ± 1) Bass X - bass (X ± 1)
High frequency emphasis	$V_{16-1}$	10	12		dB	05,8F; $f_1 = 15\text{ kHz}$ Treble max, bass lin.
High frequency emphasis	$V_{15-3}$	10	12		dB	05,8F; $f_1 = 15\text{ kHz}$ Treble max, bass lin.
High frequency emphasis	$V_{16-1}$	- 10	- 12		dB	05,8F; $f_1 = 15\text{ kHz}$ Treble max, bass lin.
High frequency emphasis	$V_{15-3}$	- 10	- 12		dB	05,8F; $f_1 = 15\text{ kHz}$ Treble max, bass lin.
Step wide treble	$\Delta V_{15}$	1	3	5	dB	05,X8-0,5 (X ± 1) 8 Treble X - treble (X ± 1)
Step wide treble	$\Delta V_{16}$	1	3	5	dB	05,X8-0,5 (X ± 1) 8 Treble X - treble (X ± 1)
Linearity sound	$\Delta V_{15}$			± 2	dB	05,88; $f_1 = 40\text{ Hz} - 15\text{ kHz}$ Treble, bass lin.
Linearity sound	$\Delta V_{16}$			± 2	dB	05,88; $f_1 = 40\text{ Hz} - 15\text{ kHz}$ Treble, bass lin.
Channel separation	$\Delta V_{15-16}$	50			dB	$V_3$ or $V_1 = 600\text{ mVrms}$
Channel separation	$\Delta V_{19-20}$	50			dB	$V_3$ or $V_1 = 600\text{ mVrms}$
Channel separation	$\Delta V_{9-10}$	50			dB	$V_3$ or $V_1 = 600\text{ mVrms}$

## Characteristics (cont'd)

 $V_S = 12\text{ V}$ ;  $T_A = 25\text{ °C}$ , in accordance with test circuit 1

Parameter	Symbol	Limit Values			Unit	Test Condition
		min.	typ.	max.		
Cross talk attenuation switch	$\alpha_{\text{input interf / Output rms}}$	60			dB	$V_{1\text{ rms}} = 0$ $V_{1\text{ Int}1,3,6} = 600\text{ mVrms}$ $V_{1\text{ Int}7,8} = 2\text{ Vrms}$
Attenuation MUTE	$\alpha_{1-16}$	80			dB	01,00-02,00 $Vol_{LSI} 0 - Vol_{LSr} 0$ $V_1 = 600\text{ mVrms}$
Attenuation MUTE	$\alpha_{1-16}$	80			dB	07,48; $V_1 = 600\text{ mVrms}$ MUTE I: 0
Attenuation MUTE	$\alpha_{1-16}$	80			dB	07,88; $V_1 = 600\text{ mVrms}$ MUTE II: 0
Attenuation MUTE	$\alpha_{3-15}$	80			dB	01,00-02,00 $Vol_{LSI} 0 - Vol_{LSr} 0$ $V_3 = 600\text{ mVrms}$
Attenuation MUTE	$\alpha_{3-15}$	80			dB	07,48; $V_3 = 600\text{ mVrms}$ MUTE I: 0
Attenuation MUTE	$\alpha_{3-15}$	80			dB	07,88; $V_3 = 600\text{ mVrms}$ MUTE II: 0
Attenuation MUTE	$\alpha_{1-20}$	80			dB	03,00; $V_1 = 600\text{ mVrms}$ $Vol_{KH} 0$
Attenuation MUTE	$\alpha_{1-20}$	80			dB	07,48; $V_1 = 600\text{ mVrms}$ MUTE I: 0
Attenuation MUTE	$\alpha_{3-19}$	80			dB	03,00; $V_3 = 600\text{ mVrms}$ $Vol_{KH} 0$
Attenuation MUTE	$\alpha_{3-19}$	80			dB	07,48; $V_3 = 600\text{ mVrms}$ MUTE I: 0
Analog values are valid for feed-in at the pin 6, 7, 8; $V_{7,8} = 2\text{ Vrms}$ ; $V_6 = 600\text{ mVrms}$						
Attenuation MUTE	$\alpha_{3-10}$	80			dB	07,48; $V_3 = 600\text{ mVrms}$ MUTE I: 0
Attenuation MUTE	$\alpha_{1-9}$	80			dB	07,48; $V_3 = 600\text{ mVrms}$ MUTE I: 0
Attenuation MUTE	$\alpha_{6-10}$	80			dB	07,49; $V_6 = 600\text{ mVrms}$ MUTE I: 0, Standard L
Attenuation MUTE	$\alpha_{6-9}$	80			dB	07,49; $V_6 = 600\text{ mVrms}$ MUTE I: 0, Standard L



## SIEMENS AKTIENGESELLSCHAFT

## Characteristics (cont'd)

 $V_S = 12\text{ V}$ ;  $T_A = 25\text{ °C}$ , in accordance with test circuit 1

Parameter	Symbol	Limit Values			Unit	Test Condition
		min.	typ.	max.		
Max. input voltage	$V_6$	600			mVrms	$THD_{15,16} = 1\%$
Max. input voltage	$V_3$	600			mVrms	$THD_{15} = 1\%$
Max. input voltage	$V_1$	600			mVrms	$THD_{16} = 1\%$
Max. input voltage	$V_1$	300			mVrms	$THD_{16} = 1\%$ ; 00,02 Matrix: Stereo
Max. input voltage	$V_7$	2			Vrms	$THD_{16} = 1\%$
Max. input voltage	$V_8$	2			Vrms	07, CC, SCART
					%	$THD_{15} = 3\%$ 07, CC, SCART
Distorsion	$THD_{19}$	0	0.01	0.1	%	$V_3 = 250\text{ mVrms}$
Distorsion	$THD_{20}$		0.01	0.1	%	$V_1 = 250\text{ mVrms}$
Distorsion	$THD_{19}$		0.01	0.1	%	$V_3 = 250\text{ mVrms}$ ; 03,15 $Vol_{KH} 21$
Distorsion	$THD_{20}$		0.01	0.1	%	$V_1 = 250\text{ mVrms}$ ; 03,15 $Vol_{KH} 21$
Analog values are valid for feed-in at the pin 6, 7, 8; $V_{7,8} = 2\text{ Vrms}$ ; $V_6 = 250\text{ mVrms}$						
Distorsion	$THD_{16}$		0.01	0.1	%	$V_1 = 250\text{ mVrms}$
Distorsion	$THD_{15}$		0.01	0.1	%	$V_3 = 250\text{ mVrms}$
Distorsion	$THD_{16}$		0.01	0.2	%	$V_1 = 250\text{ mVrms}$ ; 01 2F-02,2F $Vol_{LSI} 47$ - $Vol_{LSr} 47$
Distorsion	$THD_{15}$		0.01	0.2	%	$V_3 = 250\text{ mVrms}$ ; 01 2F-02,2F $Vol_{LSI} 47$ - $Vol_{LSr} 47$
Distorsion	$THD_{16}$		0.01	0.4	%	$V_1 = 250\text{ mVrms}$ ; 05,XX any sound
Distorsion	$THD_{15}$		0.01	0.4	%	$V_3 = 250\text{ mVrms}$ ; 05,XX any sound
Analog values are valid for feed-in at the pin 6, 7, 8; $V_{7,8} = 2\text{ Vrms}$ ; $V_6 = 250\text{ mVrms}$						
Distorsion	$THD_{10}$		0.01	0.1	%	$V_3 = 250\text{ mVrms}$
Distorsion	$THD_9$		0.01	0.1	%	$V_1 = 250\text{ mVrms}$
Distorsion	$THD_{10}$		0.01	0.1	%	$V_6 = 250\text{ mVrms}$ 07,C9, Standard L
Distorsion	$THD_9$		0.01	0.1	%	$V_1 = 250\text{ mVrms}$ 07,C9, Standard L
Antiphase Cross talk atten.	$\Delta V_{16-15}$	0.5	0.55			$V_3 = 600\text{ mVrms}$
Base width						$f_i = 2\text{ kHz}$ ; 00,11, Basis width

## SIEMENS AKTIENGESELLSCHAFT

## Characteristics (cont'd)

 $V_S = 12\text{ V}$ ;  $T_A = 25\text{ °C}$ , in accordance with test circuit 1

Parameter	Symbol	Limit Values			Unit	Test Condition
		min.	typ.	max.		
Antiphase Cross talk atten.	$\Delta V_{16-15}$	0.5	0.55			$V_3 = 600\text{ mVrms}$
Base width						$f_1 = 2\text{ kHz}$ ; 00,11, <i>Basis width</i>
Base width phase	$\Phi_{16-15}$	150	180	210	deg	$V_1 = 600\text{ mVrms}$ ; 00,11 <i>Basis width</i> , $f = 2\text{ kHz}$
Base width phase	$\Phi_{15-16}$	150	180	210	deg	$V_1 = 600\text{ mVrms}$ ; 00,11 <i>Basis width</i> , $f = 2\text{ kHz}$
Phase rotation quasi stereo	$\Phi_{16-15}$	0	10	40	deg	$V_{3,1} = 600\text{ mVrms}$ ; 00,21 <i>Quasi stereo</i> , $f = 40\text{ Hz}$
Phase rotation quasi stereo	$\Phi_{16-15}$	130	180	230	deg	$V_{3,1} = 600\text{ mVrms}$ ; 00,21 <i>Quasi stereo</i> , $f = 1\text{ kHz}$
Phase rotation quasi stereo	$\Phi_{16-15}$	-30	10	0	deg	$V_{3,1} = 600\text{ mVrms}$ ; 00,21 <i>Quasi stereo</i> , $f = 15\text{ kHz}$
Unweighted signal- to-noise ratio	$\alpha_{S/N16}$	1	90	97	dB	$V_{N\text{ rms } 20\text{ Hz-20 kHz}}$ ; $V_1 = 0.6\text{ Vrms}$
Unweighted signal- to-noise ratio	$\alpha_{S/N15}$	1	90	97	dB	$V_{N\text{ rms } 20\text{ Hz-20 kHz}}$ ; $V_3 = 0.6\text{ Vrms}$
Unweighted signal- to-noise ratio	$\alpha_{S/N16}$	70	80		dB	$V_{N\text{ rms } 20\text{ Hz-20 kHz}}$ ; $V_1 = 0.6\text{ Vrms}$ 01,27-02,27 $Vol_{LSI} 39 - Vol_{LSr} 39$
Unweighted signal- to-noise ratio	$\alpha_{S/N15}$	70	80		dB	$V_{N\text{ rms } 20\text{ Hz-20 kHz}}$ ; $V_3 = 0.6\text{ Vrms}$ 01,27-02,27 $Vol_{LSI} 39 - Vol_{LSr} 39$
External voltage	$V_{N15}$		2	10	$\mu\text{Vrms}$	$V_{N\text{ rms } 20\text{ Hz-20 kHz}}$ 01,00-02,00 $Vol_{LSI} 0 - Vol_{LSr} 0$
External voltage	$V_{N16}$		2	10	$\mu\text{Vrms}$	$V_{N\text{ rms } 20\text{ Hz-20 kHz}}$ 01,00-02,00 $Vol_{LSI} 0 - Vol_{LSr} 0$

## SIEMENS AKTIENGESELLSCHAFT

## Characteristics (cont'd)

 $V_S = 12\text{ V}$ ;  $T_A = 25\text{ °C}$ , in accordance with test circuit 1

Parameter	Symbol	Limit Values			Unit	Test Condition
		min.	typ.	max.		
Unweighted signal-to-noise ratio	$\alpha_{S/N20}$	90	97		dB	$V_{N\text{ rms } 20\text{ Hz-20 kHz}}$ ; $V_1 = 0.6\text{ Vrms}$
Unweighted signal-to-noise ratio	$\alpha_{S/N19}$	1	90	97	dB	$V_{N\text{ rms } 20\text{ Hz-20 kHz}}$ ; $V_3 = 0.6\text{ Vrms}$
Unweighted signal-to-noise ratio	$\alpha_{S/N20}$	70	80		dB	$V_{N\text{ rms } 20\text{ Hz-20 kHz}}$ ; $V_1 = 0.6\text{ Vrms}$ 03,10, $Vol_{KH} 16$
Unweighted signal-to-noise ratio	$\alpha_{S/N19}$	70	80		dB	$V_{N\text{ rms } 20\text{ Hz-20 kHz}}$ ; $V_3 = 0.6\text{ Vrms}$ 03,10, $Vol_{KH} 16$
External voltage	$V_{N20}$		2	10	$\mu\text{Vrms}$	$V_{N\text{ rms } 20\text{ Hz-20 kHz}}$ ; 03,00 $Vol_{KH} 0$
External voltage	$V_{N19}$		2	10	$\mu\text{Vrms}$	$V_{N\text{ rms } 20\text{ Hz-20 kHz}}$ ; 03,00 $Vol_{KH} 0$
Unweighted signal-to-noise ratio	$\alpha_{S/N9}$	1	90	97	dB	$V_{N\text{ rms } 20\text{ Hz-20 kHz}}$ ; $V_1 = 0.6\text{ Vrms}$
Unweighted signal-to-noise ratio	$\alpha_{S/N10}$	1	90	97	dB	$V_{N\text{ rms } 20\text{ Hz-20 kHz}}$ ; $V_1 = 0.6\text{ Vrms}$
Change of DC-switch $\Delta 1$ Bit	$\Delta V_{16}$			$\pm 10$	mV	01,X-01,X $\pm 1$ $Vol_{LSI} X - Vol_{LSI} (X \pm 1)$
Change of DC-switch $\Delta 1$ Bit	$\Delta V_{15}$			$\pm 10$	mV	02,X-02,X $\pm 1$ $Vol_{LSr} X - Vol_{LSr} (X \pm 1)$
Change of DC-switch $\Delta 1$ Bit	$\Delta V_{16}$			$\pm 10$	mV	05,X-05,X $\pm 1$ Sound X-Sound $(X \pm 1)$
Change of DC-switch $\Delta 1$ Bit	$\Delta V_{15}$			$\pm 10$	mV	05,X-05,X $\pm 1$ Sound X-Sound $(X \pm 1)$
Change of DC-switch $\Delta 1$ Bit	$\Delta V_{19}$			$\pm 10$	mV	03,X-03,X $\pm 1$ $Vol_{KH} X - Vol_{KH} (X \pm 1)$
Change of DC-switch $\Delta 1$ Bit	$\Delta V_{20}$			$\pm 10$	mV	03,X-03,X $\pm 1$ $Vol_{KH} X - Vol_{KH} (X \pm 1)$

**Characteristics** (cont'd) $V_S = 12\text{ V}$ ;  $T_A = 25\text{ °C}$ , in accordance with test circuit 1

Parameter	Symbol	Limit Values			Unit	Test Condition
		min.	typ.	max.		

**Design-Related Data**

Input resistance	$R_7$	35			$k\Omega$	
Input resistance	$R_8$	35			$k\Omega$	
Input resistance	$R_6$	20			$k\Omega$	
Input resistance	$R_3$	20			$k\Omega$	
Input resistance	$R_1$	20			$k\Omega$	
Output resistance	$R_{19}$			200	$\Omega$	
Output resistance	$R_{20}$			200	$\Omega$	
Output resistance	$R_{15}$			200	$\Omega$	
Output resistance	$R_{16}$			200	$\Omega$	
Output resistance	$R_9$			200	$\Omega$	
Output resistance	$R_{10}$			200	$\Omega$	

SIEMENS AKTIENGESELLSCHAFT

**Characteristics (cont'd)**

$V_S = 12\text{ V}; T_A = 25\text{ °C}$

Parameter	Symbol	Limit Values			Unit	Test Condition	Test Circuit
		min.	typ.	max.			

**ID-Signal Decoder**

Gain Filter OP-amp	$V_5$	13	14	15	dB	$V_{IF} = 80\text{ mVpp}$	1
Max. input voltage	$V_5$	6			mVpp	Function	2
VCO voltage PLL	$V_{27}$	1.3			V	$f_{24} = 14.6\text{ kHz};$ $V_{24} = 2.5\text{ V}_{OS}$	2
VCO voltage PLL	$V_{27}$	2	3	4	V	$f_{24} = 15.625\text{ kHz};$ $V_{24} = 2.5\text{ V}_{OS}$	2
VCO voltage PLL	$V_{27}$			4.7	V	$f_{24} = 16.6\text{ kHz};$ $V_{24} = 2.5\text{ V}_{OS}$	2
VCO voltage PLL	$V_{27}$	1.3			V	$f_{24} = 58.4\text{ kHz};$ $V_{24} = 2.5\text{ V}_{OS}$ 00,09, H-Imp	2
VCO voltage PLL	$V_{27}$			4.7	V	$f_{24} = 66.4\text{ kHz};$ $V_{24} = 2.5\text{ V}_{OS}$ 00,09, H-Imp	2

$$V_{KT\text{ FILTER}} = \frac{\sqrt{(V_{25} - V_{25}^*)^2 + (V_{26} - V_{26}^*)^2}}{V_5} \quad \begin{matrix} V_{25} \text{ or } V_{26} \text{ when } V_5 = 0 \\ V_{25}^* \text{ or } V_{26}^* \text{ when } V_5 = 400\text{ mVpp} \end{matrix}$$

ID-filter gain	$V_{KT\text{ Filter}}$	3.4		6.8		$f_5 = \text{Pilot signal: Dual}$ I <sup>2</sup> C-talk: Dual	
ID-filter gain	$V_{KT\text{ Filter}}$	3.4		6.8		$f_5 = \text{Pilot signal: Stereo}$ I <sup>2</sup> C-talk: Stereo	

$$V_{25\text{ test}} = V_{25} (V_5 = 0) \pm \Delta V_{25}; V_{26\text{ test}} = V_{26} (V_5 = 0) \pm \Delta V_{26}$$

Detection threshold	$\Delta V_{25}$	900			mV	I <sup>2</sup> C-talk: Stereo o. Dual	3
Detection threshold	$-\Delta V_{25}$	900			mV	I <sup>2</sup> C-talk: Stereo o. Dual	3
Detection threshold	$\Delta V_{26}$	900			mV	I <sup>2</sup> C-talk: Stereo o. Dual	3
Detection threshold	$-\Delta V_{26}$	900			mV	I <sup>2</sup> C-talk: Stereo o. Dual	3

## Characteristics (cont'd)

 $V_S = 12\text{ V}$ ;  $T_A = 25\text{ °C}$ 

Parameter	Symbol	Limit Values			Unit	Test Condition	Test Circuit
		min.	typ.	max.			
Mono threshold	$\Delta V_{25}$	0		100	mV	I <sup>2</sup> C-talk: Mono	3
Mono threshold	$-\Delta V_{25}$	0		100	mV	I <sup>2</sup> C-talk: Mono	3
Mono threshold	$\Delta V_{26}$	0		100	mV	I <sup>2</sup> C-talk: Mono	3
Mono threshold	$-\Delta V_{26}$	0		100	mV	I <sup>2</sup> C-talk: Mono	3
Detection response	$t_{det}$	1/4		1/2	$t_{MPX}$	I <sup>2</sup> C-talk: Stereo o. Dual $\pm \Delta V_{25} = 1\text{ V}$	3
Detection response	$t_{det}$	1/4		1/2	$t_{MPX}$	I <sup>2</sup> C-talk: Stereo o. Dual $\pm \Delta V_{25} = 1\text{ V}$	3
Switching threshold $f_{REF}$ -input	$V_{24L}$	0		1.5	V		2
Switching threshold $f_{REF}$ -input	$V_{24L}$	3.5		$V_{21}$	V		2
Multiplexer clock	$t_{MPX}$		1.08		s	00,C0, MPX = 1 s	
Multiplexer clock	$t_{MPX}$		2.17		s	00,C0, MPX = 2 s	
Multiplexer clock	$t_{MPX}$		4.34		s	00,C0, MPX = 4 s	
Multiplexer clock	$t_{MPX}$		8.68		s	00,C0, MPX = 8 s	

## Design-Related Data

Filter output resistance	$R_{25, 26}$	110			k $\Omega$		
$f_{REF}$ -input resistance	$R_{24}$	7			k $\Omega$		

## SIEMENS AKTIENGESELLSCHAFT

## Characteristics

 $V_S = 12\text{ V}$ ;  $T_A = 25\text{ }^\circ\text{C}$ 

Parameter	Symbol	Limit Values			Unit
		min.	typ.	max.	
<b>I<sup>2</sup>C-Bus (SCL, SDA)</b>					
SCL, SDA edges					
Rise time	$t_R$			1	$\mu\text{s}$
Fall time	$t_F$			300	ns
Shift register clock pulse SCL					
Frequency	$f_{\text{SCL}}$	0		100	kHz
H-pulse width	$t_{\text{HIGH}}$	4			$\mu\text{s}$
L-pulse width	$t_{\text{LOW}}$	4			$\mu\text{s}$
Start					
Setup time	$t_{\text{SUSTA}}$	4			$\mu\text{s}$
Hold time	$t_{\text{HDSTA}}$	4			$\mu\text{s}$
Stop					
Setup time	$t_{\text{SUSTO}}$	4			$\mu\text{s}$
Bus free time	$t_{\text{BUF}}$	4			$\mu\text{s}$
Data transfer					
Setup time	$t_{\text{SUDAT}}$	1			$\mu\text{s}$
Hold time	$t_{\text{HDDAT}}$	1			$\mu\text{s}$
Input SCL, SDA					
Input voltage	$V_{\text{QH}}$ $V_{\text{QL}}$	2.4		5.5 1	V V
Input current	$I_{\text{QH}}$ $I_{\text{QL}}$			20 20	$\mu\text{A}$ $\mu\text{A}$
Output SDA (open collector)					
Output voltage	$V_{\text{QH}}$ $V_{\text{QL}}$	5.4			V V
$R_L = 2.5\text{ k}\Omega$ $I_{\text{QL}} = 3\text{ mA}$				0.4	

SIEMENS AKTIENGESELLSCHAFT

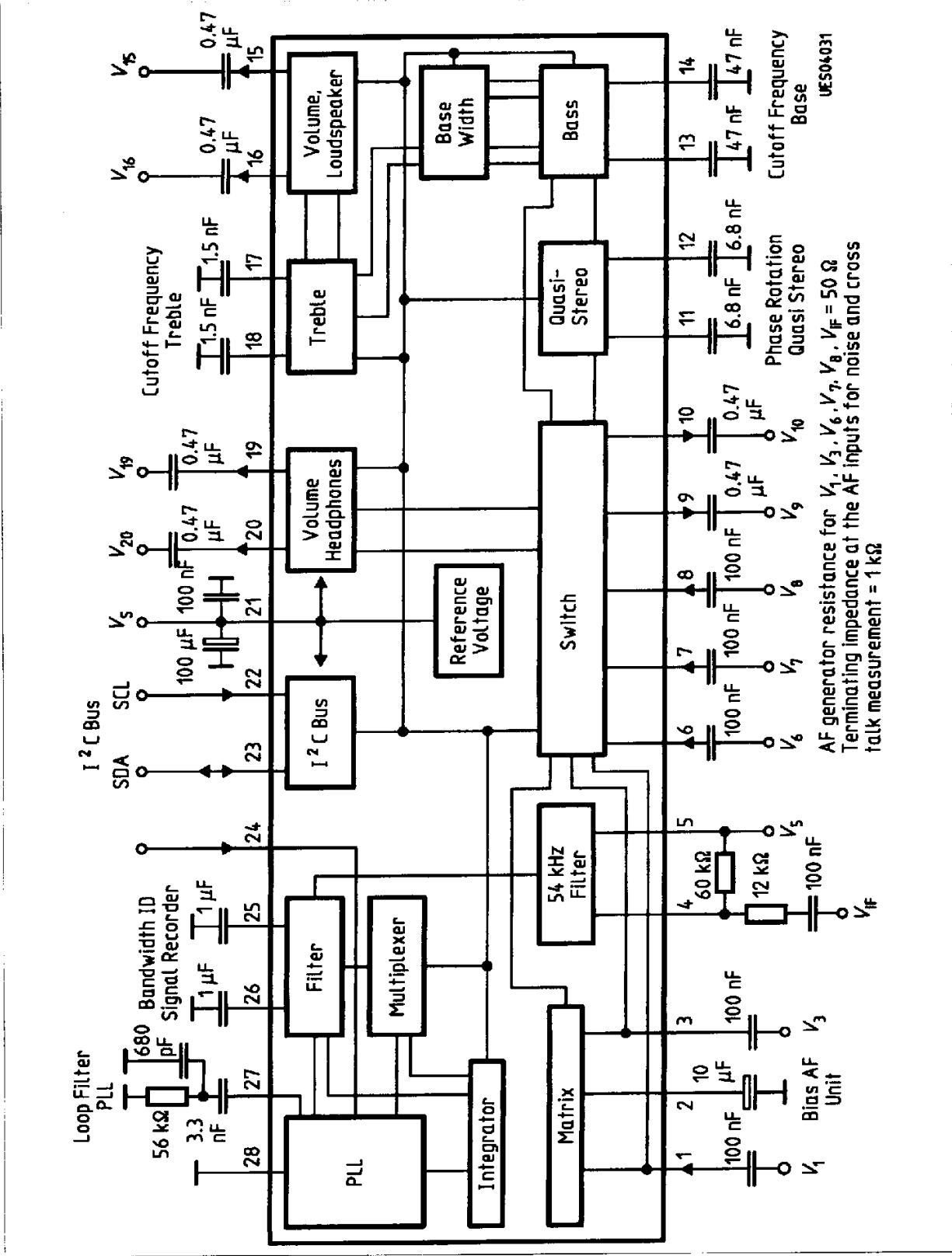

Test Circuit 1



SIEMENS AKTIENGESELLSCHAFT

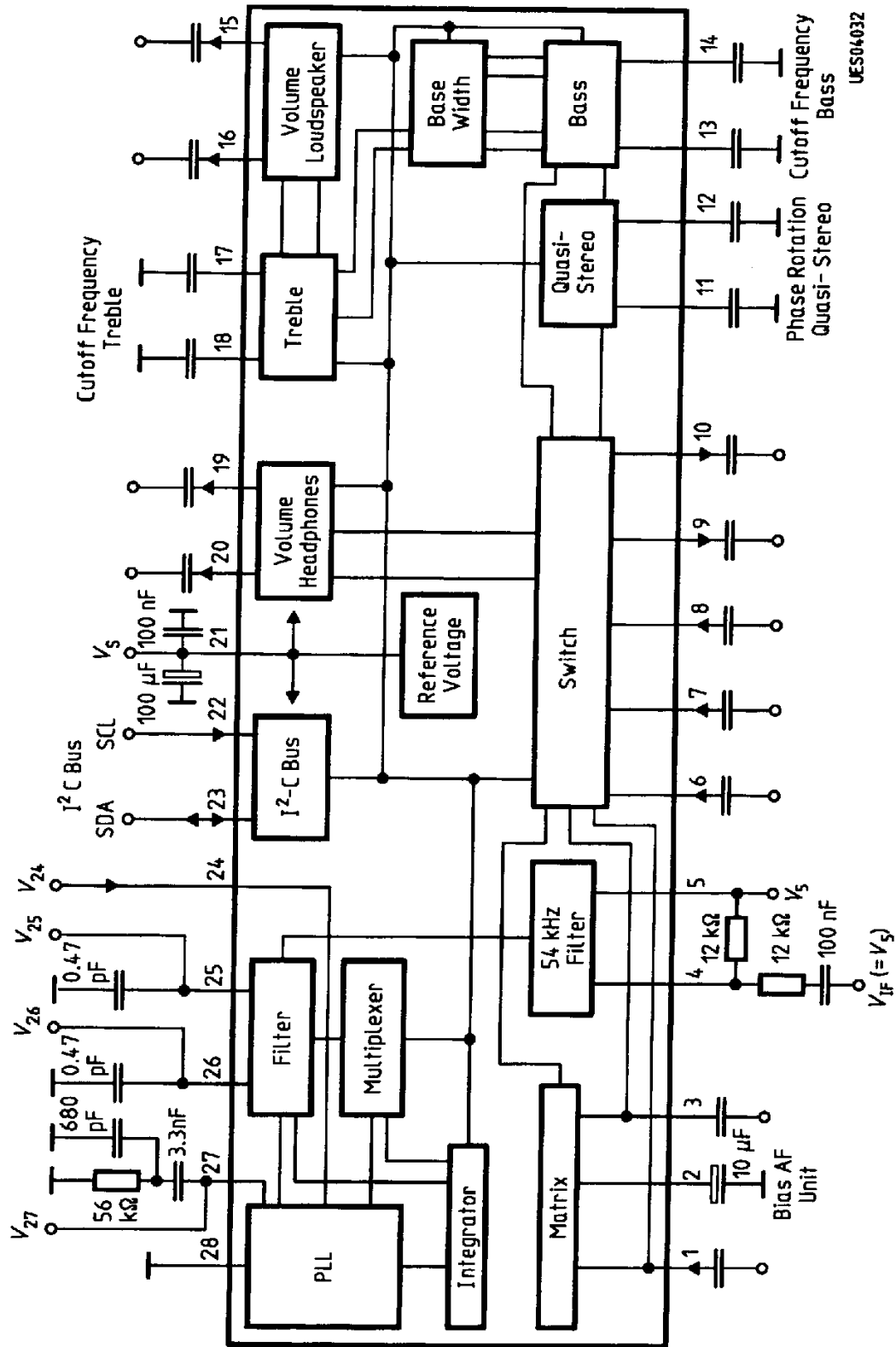

UES04032

Test Circuit 2

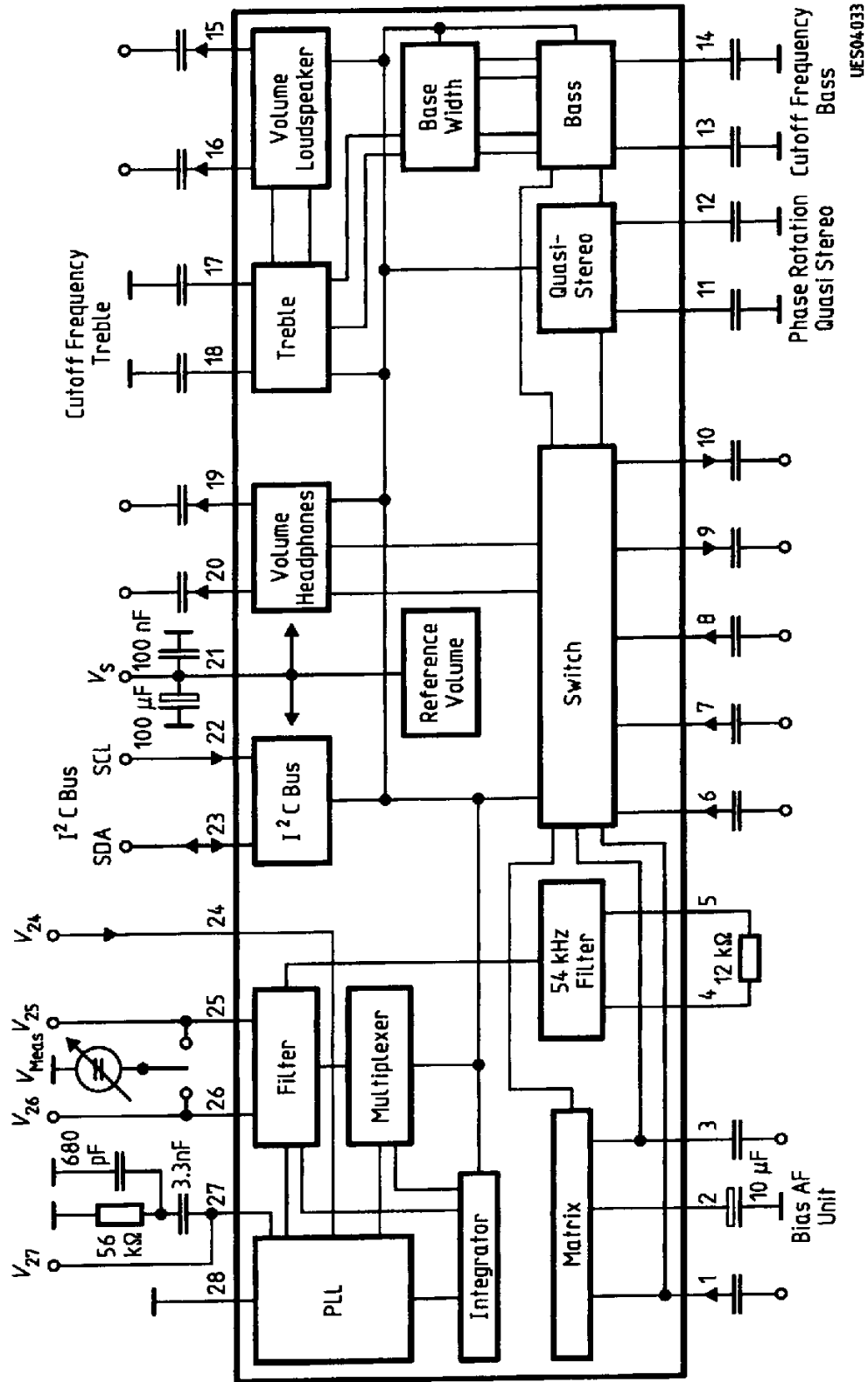

UES04033

Test Circuit 3

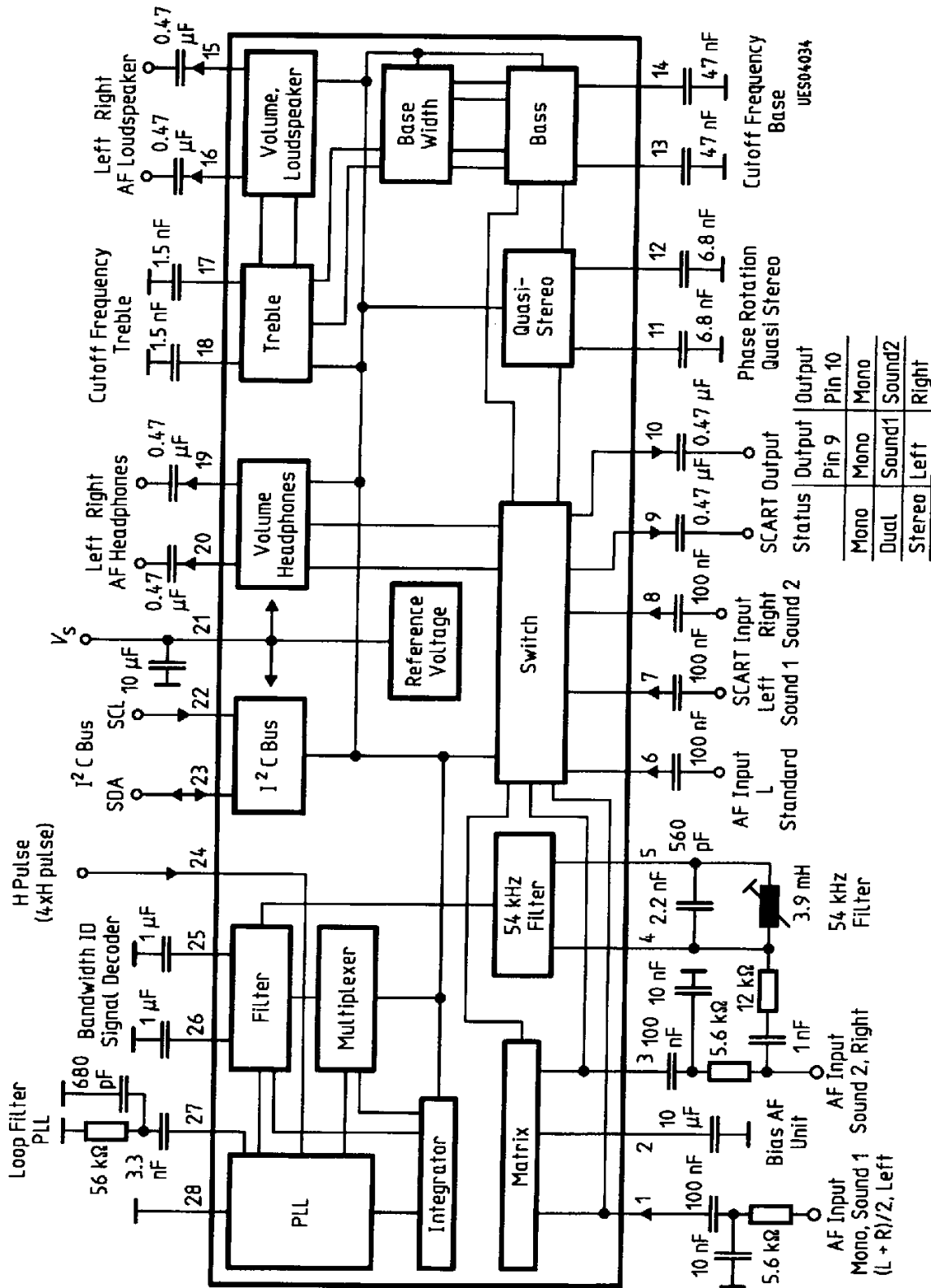

Application Circuit 1

SIEMENS AKTIENGESELLSCHAFT

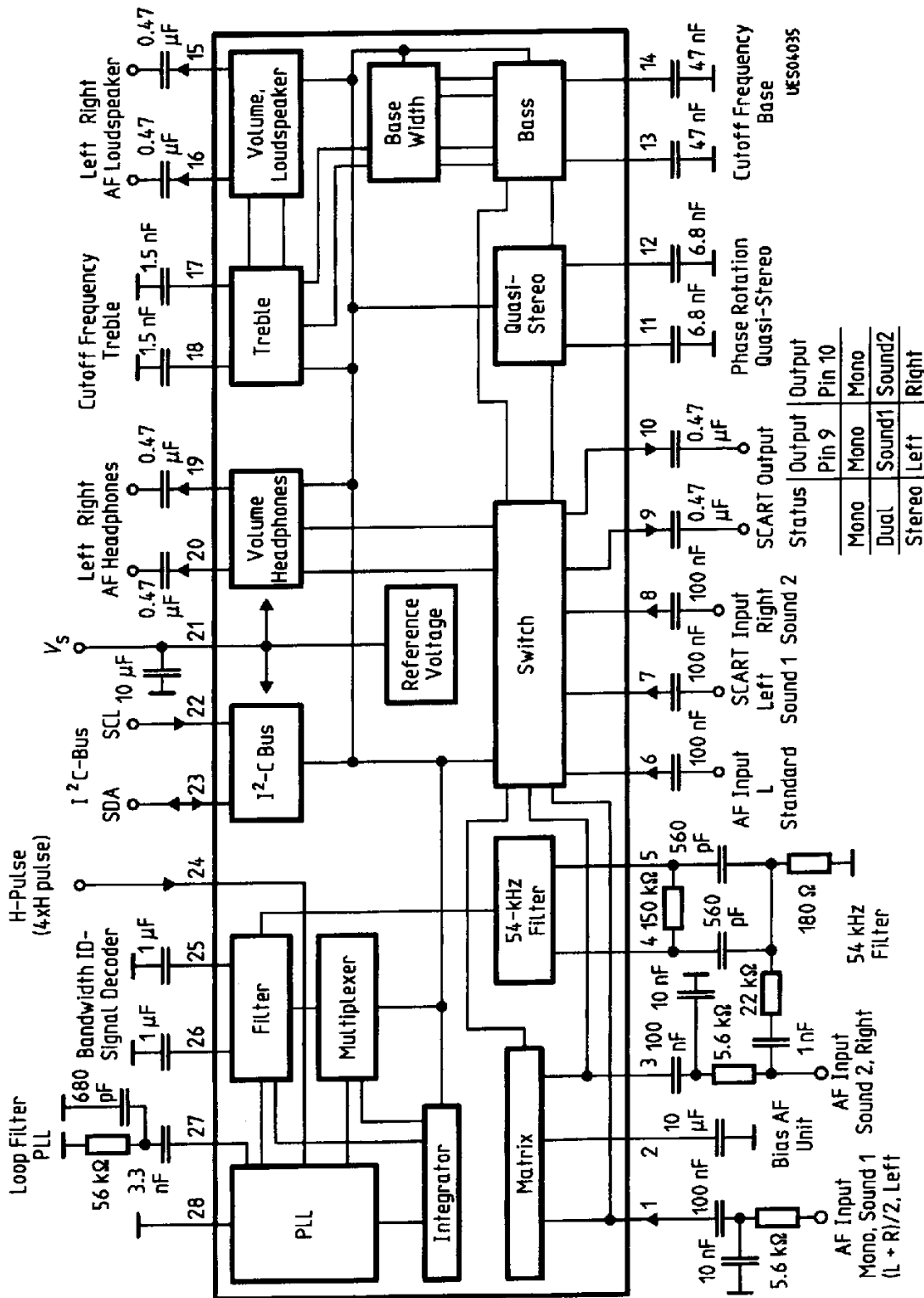

Application Circuit 2

SIEMENS AKTIENGESELLSCHAFT

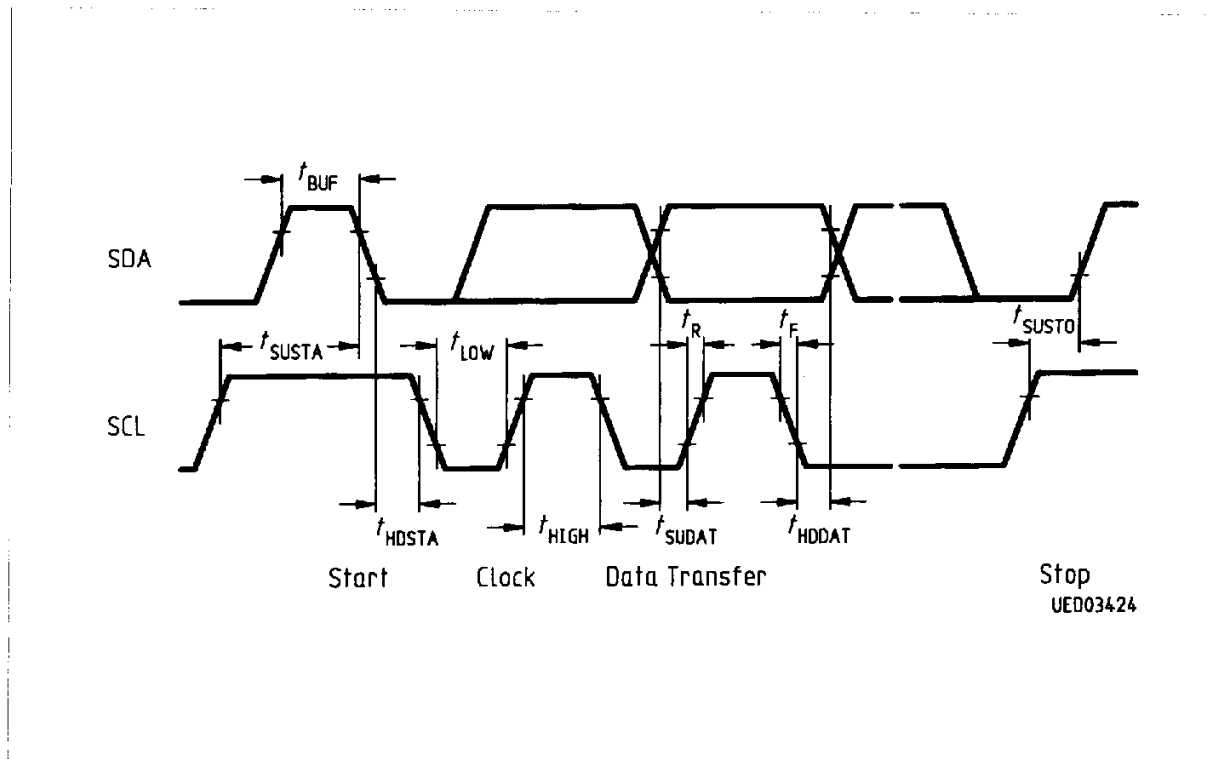
**I<sup>2</sup>C-Bus Timing Diagram**

$t_{SUSTA}$	Setup time (start)
$t_{HDSTA}$	Hold time (start)
$t_{HIGH}$	H-pulse width (clock)
$t_{LOW}$	L-pulse width (clock)
$t_{SUDAT}$	Setup time (data transfer)
$t_{HDDAT}$	Hold time (data transfer)
$t_{SUSTO}$	Setup time (stop)
$t_{BUF}$	Bus free time
$t_F$	Fall time
$t_R$	Rise time

All times referred to  $V_{IH}$  and  $V_{IL}$  values.