

ZXLD1370
60V HIGH ACCURACY BUCK/BOOST/BUCK-BOOST LED DRIVER CONTROLLER

Description

The ZXLD1370 is an LED driver controller IC for driving external MOSFETs to drive high current LEDs. It is a multi-topology controller enabling it to efficiently control the current through series connected LEDs. The multi-topology enables it to operate in buck, boost and buck-boost configurations. The 60V capability coupled with its multi-topology capability enables it to be used in a wide range of applications and drive in excess of 15 LEDs in series.

The ZXLD1370 is a modified hysteretic controller using a patent pending control scheme providing high output current accuracy in all three modes of operation. High accuracy dimming is achieved through DC control and high frequency PWM control.

The ZXLD1370 uses two pins for fault diagnosis. A flag output highlights a fault, while the multi-level status pin gives further information on the exact fault.

Features

- 0.5% typical output current accuracy
- 6 to 60V operating voltage range
- LED driver supports Buck, Boost and Buck-boost configurations
- Wide dynamic range dimming
 - 20:1 DC dimming
 - 1000:1 dimming range at 500Hz
- Up to 1MHz switching
- High temperature control of LED current using T_{ADJ}

Typical Application Circuit

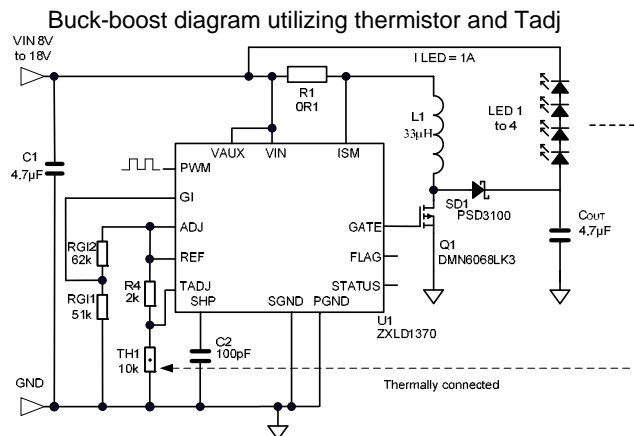

Pin Assignments

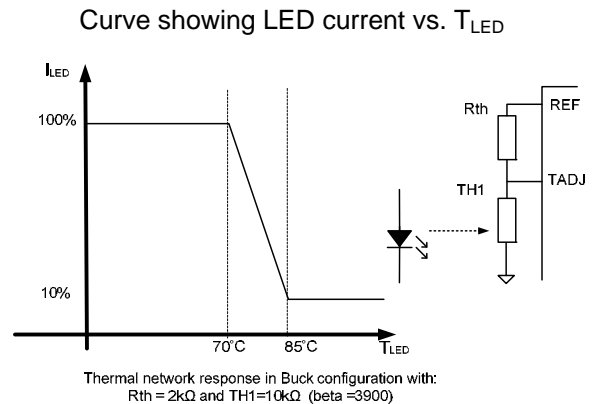
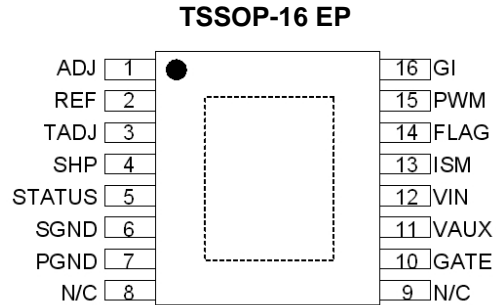

Pin Descriptions

Pin Name	Pin	Type [‡]	Description
ADJ	1	I	Adjust input (for dc output current control) Connect to REF to set 100% output current. Drive with dc voltage ($125\text{mV} < V_{\text{ADJ}} < 2.5\text{V}$) to adjust output current from 10% to 200% of set value. The ADJ pin has an internal clamp that limits the internal node to less than 3V. This provides some failsafe should they get overdriven
REF	2	O	Internal 1.25V reference voltage output
TADJ	3	I	Temperature Adjust input for LED thermal current control Connect thermistor/resistor network to this pin to reduce output current above a preset temperature threshold. Connect to REF to disable thermal compensation function. (See section on thermal control.)
SHP	4	I/O	Shaping capacitor for feedback control loop Connect 100pF $\pm 20\%$ capacitor from this pin to ground to provide loop compensation
STATUS	5	O	Operation status output (analog output) Pin is at 4.5V (nominal) during normal operation. Pin switches to a lower voltage to indicate specific operation warnings or fault conditions. (See section on STATUS output.) Status pin voltage is low during shutdown mode
SGND	6	P	Signal ground (Connect to 0V)
PGND	7	P	Power ground - Connect to 0V and pin 8 to maximize copper area
N/C	8	-	Not Connected internally – recommend connection to pin 7, (PGND), to maximize PCB copper for thermal dissipation
N/C	9	-	Not Connected internally – recommend connection pin 10 (GATE) to permit wide copper trace to gate of MOSFET
GATE	10	O	Gate drive output to external NMOS transistor – connect to pin 9
V _{AUX}	11	P	Auxiliary positive supply to internal switch gate driver Connect to V _{IN} , or auxiliary supply from 6V to 15V supply to reduce internal power dissipation (Refer to application section for more details) Decouple to ground with capacitor close to device (refer to Applications section)
V _{IN}	12	P	Input supply to device (6V to 60V) Decouple to ground with capacitor close to device (refer to Applications section)
ISM	13	I	Current monitor input. Connect current sense resistor between this pin and V _{IN} The nominal voltage across the resistor is 225mV
FLAG	14	O	Flag open drain output Pin is high impedance during normal operation Pin switches low to indicate a fault, or warning condition
PWM	15	I	Digital PWM output current control Pin driven either by open Drain or push-pull 3.3V or 5V logic levels. Drive with frequency higher than 100Hz to gate output 'on' and 'off' during dimming control The device enters standby mode when PWM pin is driven with logic low level for more than 15ms nominal (Refer to application section for more details)
GI	16	I	Gain setting input Used to set the device in Buck mode or Boost, Buck-boost modes Connect to ADJ in Buck mode operation For Boost and Buck-boost modes, connect to resistive divider from ADJ to SGND. This defines the ratio of switch current to LED current (see application section). The GI pin has an internal clamp that limits the internal node to less than 3V. This provides some failsafe should they get overdriven
EP	PAD	P	Exposed paddle. Connect to 0V plane for electrical and thermal management

Notes: [‡]. Type refers to whether or not pin is an Input, Output, Input/Output or Power supply pin.

Absolute Maximum Ratings (Voltages to GND Unless Otherwise Stated)

Symbol	Parameter	Rating	Unit
V _{IN}	Input supply voltage relative to GND	-0.3 to 65	V
V _{AUX}	Auxiliary supply voltage relative to GND	-0.3 to 65	V
V _{ISM}	Current monitor input relative to GND	-0.3 to 65	V
V _{SENSE}	Current monitor sense voltage (V _{IN} -V _{ISM})	-0.3 to 5	V
V _{GATE}	Gate driver output voltage	-0.3 to 20	V
I _{GATE}	Gate driver continuous output current	18	mA
V _{FLAG}	Flag output voltage	-0.3 to 40	V
V _{PWM} , V _{ADJ} , V _{TADJ} , V _{GI} , V _{PWM}	Other input pins	-0.3 to 5.5	V
T _J	Maximum junction temperature	150	°C
T _{ST}	Storage temperature	-55 to 150	°C

These are stress ratings only. Operation outside the absolute maximum ratings may cause device failure. Operation at the absolute maximum rating for extended periods may reduce device reliability.

Recommended Operating Conditions

Symbol	Parameter	Performance/Comment	Min	Max	Unit
V _{IN}	Input supply voltage range	Normal operation	8	60	V
		Functional (Note 1)	6.3		
V _{AUX}	Auxiliary supply voltage range (Note 2)	Normal operation	8	60	V
		Functional	6.3		
V _{ISM}	Current sense monitor input range		6.3	60	V
V _{SENSE}	Differential input voltage	V _{IN} -V _{ISM} , with 0 ≤ V _{ADJ} ≤ 2.5	0	450	mV
V _{ADJ}	External dc control voltage applied to ADJ pin to adjust output current	DC brightness control mode from 10% to 200%	0.125	2.5	V
I _{REF}	Reference external load current	REF sourcing current		1	mA
f _{max}	Recommended switching frequency range (Note 3)		300	1000	kHz
V _{TADJ}	Temperature adjustment (T _{ADJ}) input voltage range		0	V _{REF}	V
f _{PWM}	Recommended PWM dimming frequency range (Note 4)	To achieve 1000:1 resolution	100	500	Hz
		To achieve 500:1 resolution	100	1000	Hz
t _{PWMH/L}	PWM pulse width in dimming mode	PWM input high or low	0.002	10	ms
V _{PWMH}	PWM pin high level input voltage		2	5.5	V
V _{PWML}	PWM pin low level input voltage		0	0.4	V
T _J	Operating Junction Temperature Range		-40	125	°C
GI	Gain setting ratio for boost and buck-boost modes	Ratio= V _{GI} /V _{ADJ}	0.20	0.50	

- Notes:
1. The functional range of V_{IN} is the voltage range over which the device will function. Output current and device parameters may deviate from their normal values for V_{IN} and V_{AUX} voltages between 6V and 8V, depending upon load and conditions.
 2. V_{AUX} can be driven from a voltage higher than V_{IN} to provide higher efficiency at low V_{IN} voltages, but to avoid false operation; a voltage should not be applied to V_{AUX} in the absence of a voltage at V_{IN}.
 3. The device contains circuitry to control the switching frequency to approximately 400kHz. The maximum and minimum operating frequency are not tested in production.
 4. This gives maximum resolution at the expense of accuracy. To ensure accuracy the following equation should be used: 2*Resolution *f_{PWM} < f_{SWH}

Electrical Characteristics (Test conditions: $V_{IN} = V_{AUX} = 12V$, $T_A = 25^{\circ}C$, unless otherwise specified.)

Symbol	Parameter	Conditions	Min	Typ	Max	Units
Supply and reference parameters						
V_{UV-}	Under-Voltage detection threshold Normal operation to switch disabled	V_{IN} or V_{AUX} falling	5.2	5.6	6.3	V
V_{UV+}	Under-Voltage detection threshold Switch disabled to normal operation	V_{IN} or V_{AUX} rising	5.5	6	6.5	V
I_{Q-IN}	Quiescent current into V_{IN}	PWM pin floating. Output not switching		1.5	3	mA
I_{Q-AUX}	Quiescent current into V_{AUX}			150	300	μA
I_{SB-IN}	Standby current into V_{IN} .	PWM pin grounded for more than 15ms		90	150	μA
I_{SB-AUX}	Standby current into V_{AUX} .			0.7	10	μA
V_{REF}	Internal reference voltage	No load	1.237	1.25	1.263	V
ΔV_{REF}	Change in reference voltage with output current	Sourcing 1mA Sinking 100 μA	-5		5	mV
V_{REF_LINE}	Reference voltage line regulation	$V_{IN} = V_{AUX}$, $6.5V < V_{IN} < 60V$	-60	-90		dB
V_{REF-TC}	Reference temperature coefficient			+/-50		ppm/ $^{\circ}C$
DC-DC converter parameters						
V_{ADJ}^{\dagger}	External dc control voltage applied to ADJ pin to adjust output current	DC brightness control mode 10% to 200%	0.125	1.25	2.5	V
I_{ADJ}	ADJ input current	$V_{ADJ} \leq 2.5V$ $V_{ADJ} = 5.0V^{\dagger}$			100 5	nA μA
V_{GI}^{\dagger}	GI Voltage threshold for boost and buck-boost modes selection	$V_{ADJ} = 1.25V$			0.8	V
I_{GI}	GI input current	$V_{GI} \leq 2.5V$ $V_{GI} = 5.0V^{\dagger}$			100 5	nA μA
I_{PWM}	PWM input current	$V_{PWM} = 5.5V$		36	100	μA
t_{PWMoff}	PWM pulse width (to enter shutdown state)	PWM input low	10	15	25	ms
T_{SDH}	Thermal shutdown upper threshold (GATE output forced low)	Temperature rising.		150		$^{\circ}C$
T_{SDL}	Thermal shutdown lower threshold (GATE output re-enabled)	Temperature falling.		125		$^{\circ}C$
High-Side Current Monitor (Pin ISM)						
I_{ISM}	Input Current	Measured into ISM pin and $V_{ISM} = 12V$		11	20	μA
V_{SENSE_acc}	Accuracy of nominal V_{SENSE} threshold voltage	$V_{ADJ} = 1.25V$		± 0.25	± 2	%
$V_{SENSE-OC}$	Over-current sense threshold voltage		300	350	375	mV

Notes: [†] The ADJ and GI pins have an internal clamp that limits the internal node to less than 3V. This provides some failsafe should those pins get overdriven.

Electrical Characteristics (Test conditions: $V_{IN} = V_{AUX} = 12V$, $T_A = 25^\circ C$, unless otherwise specified.)

Symbol	Parameter	Conditions	Min	Typ	Max	Units
Output Parameters						
V_{FLAGL}	FLAG pin low level output voltage	Output sinking 1mA			0.5	V
$I_{FLAGOFF}$	FLAG pin open-drain leakage current	$V_{FLAG}=40V$			1	μA
V_{STATUS}	STATUS Flag no-load output voltage (Note 5)	Normal operation	4.2	4.5	4.8	V
		Out of regulation (V_{SHP} out of range) (Note 6)	3.3	3.6	3.9	
		V_{IN} under-voltage ($V_{IN} < 5.6V$)	3.3	3.6	3.9	
		Switch stalled (t_{ON} or $t_{OFF} > 100\mu s$)	3.3	3.6	3.9	
		Over-temperature ($T_J > 125^\circ C$)	1.5	1.8	2.1	
	Excess sense resistor current ($V_{SENSE} > 0.32V$)	0.6	0.9	1.2		
R_{STATUS}	Output impedance of STATUS output	Normal operation		10		k Ω
Driver output (PIN GATE)						
V_{GATEH}	High level output voltage	No load Sourcing 1mA (Note 7)	10	11		V
V_{GATEL}	Low level output voltage	Sinking 1mA, (Note 8)			0.5	V
V_{GATECL}	High level GATE CLAMP voltage	$V_{IN} = V_{AU X} = V_{ISM} = 18V$ $I_{GATE} = 1mA$		12.8	15	V
I_{GATE}	Dynamic peak current available during rise or fall of output voltage	Charging or discharging gate of external switch with $Q_G = 10nC$ and 400kHz		± 300		mA
t_{STALL}	Time to assert 'STALL' flag and warning on STATUS output (Note 9)	GATE low or high		100	170	μs
LED Thermal control circuit (TADJ) parameters						
V_{TADJH}	Upper threshold voltage	Onset of output current reduction (V_{TADJ} falling)	560	625	690	mV
V_{TADJL}	Lower threshold voltage	Output current reduced to <10% of set value (V_{TADJ} falling)	380	440	500	mV
I_{TADJ}	TADJ pin Input current	$V_{TADJ} = 1.25V$			1	μA

- Notes:
- In the event of more than one fault/warning condition occurring, the higher priority condition will take precedence. E.g. 'Excessive coil current' and 'Out of regulation' occurring together will produce an output of 0.9V on the STATUS pin. The voltage levels on the STATUS output assume the internal regulator to be in regulation and $V_{ADJ} \leq V_{REF}$. A reduction of the voltage on the STATUS pin will occur when the voltage on V_{IN} is near the minimum value of 6V.
 - Flag is asserted if $V_{SHP} < 2.5V$ or $V_{SHP} > 3.5V$
 - GATE is switched to the supply voltage V_{AUX} for low values of V_{AUX} (i.e. between 6V and approximately 12V). For $V_{AUX} > 12V$, GATE is clamped internally to prevent it exceeding 15V.
 - GATE is switched to PGND by an NMOS transistor
 - If t_{ON} exceeds t_{STALL} , the device will force GATE low to turn off the external switch and then initiate a restart cycle. During this phase, ADJ is grounded internally and the SHP pin is switched to its nominal operating voltage, before operation is allowed to resume. Restart cycles will be repeated automatically until the operating conditions are such that normal operation can be sustained. If t_{OFF} exceeds t_{STALL} , the switch will remain off until normal operation is possible.

Typical Characteristics – Buck Mode – $R_S = 150m\Omega$ – $L = 33\mu H$ – $I_{LED} = 1.5A$

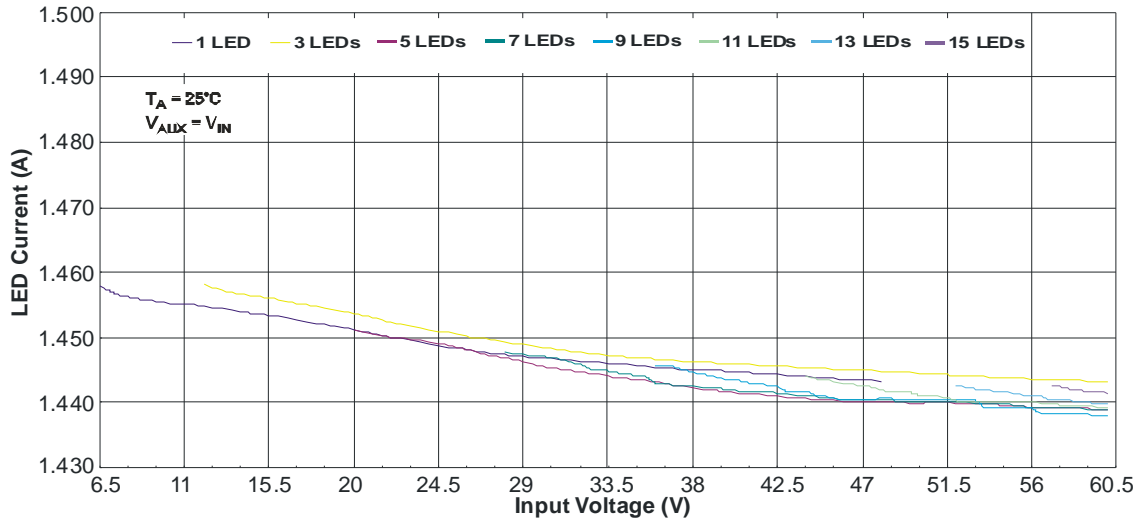

Figure 1: Load Current vs. Input Voltage & Number of LED

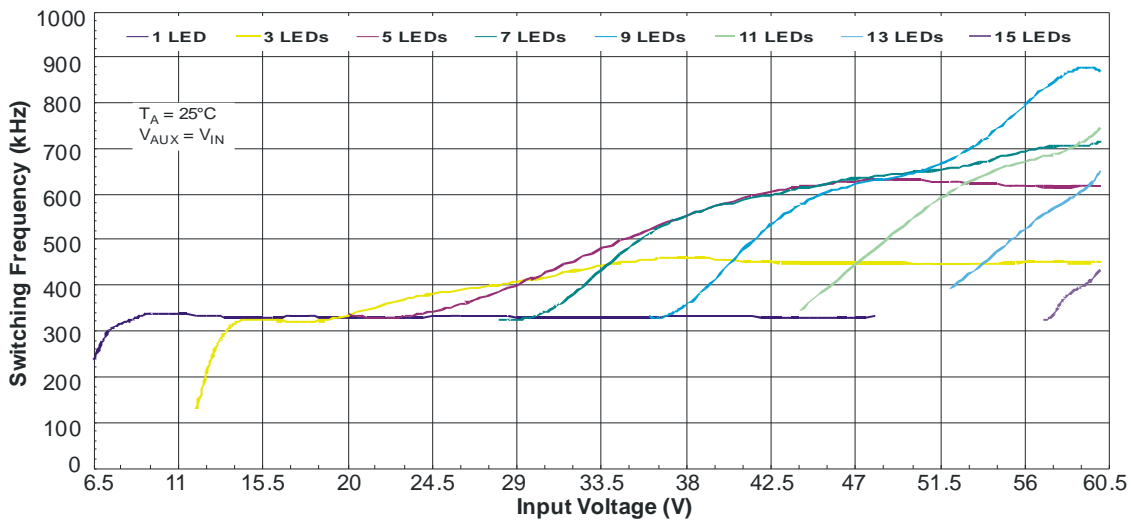

Figure 2: Frequency vs. Input Voltage & Number of LED

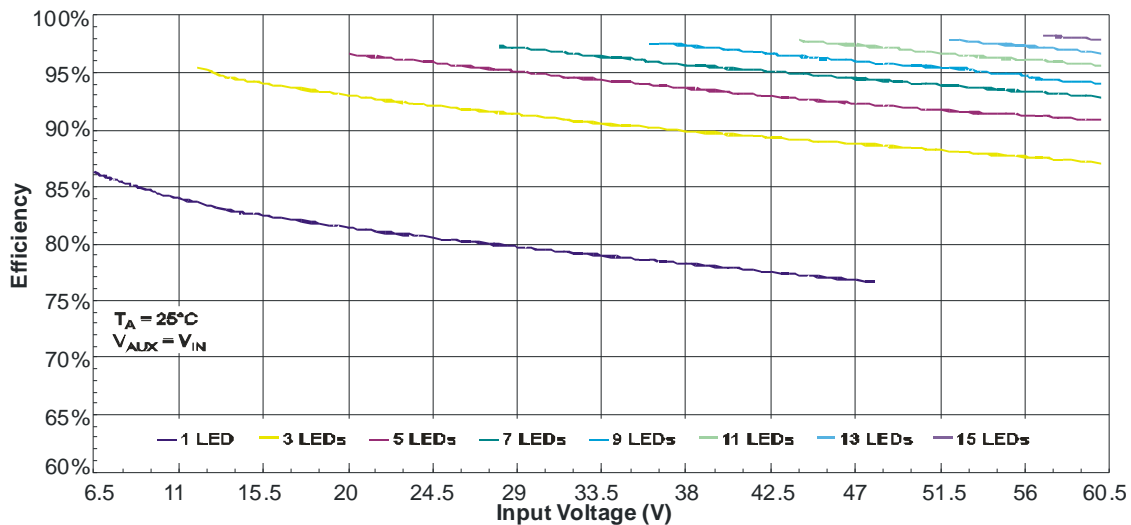
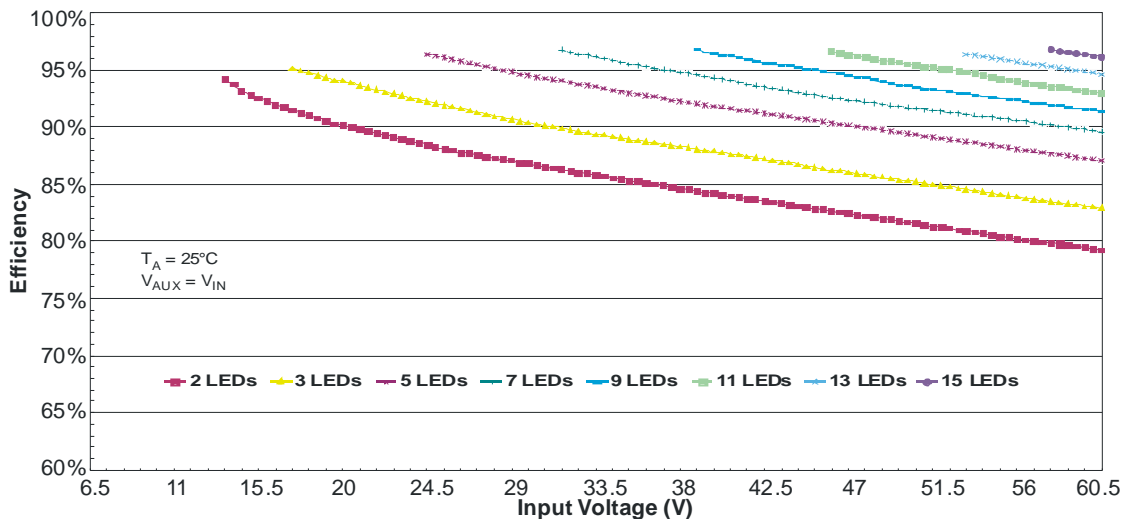
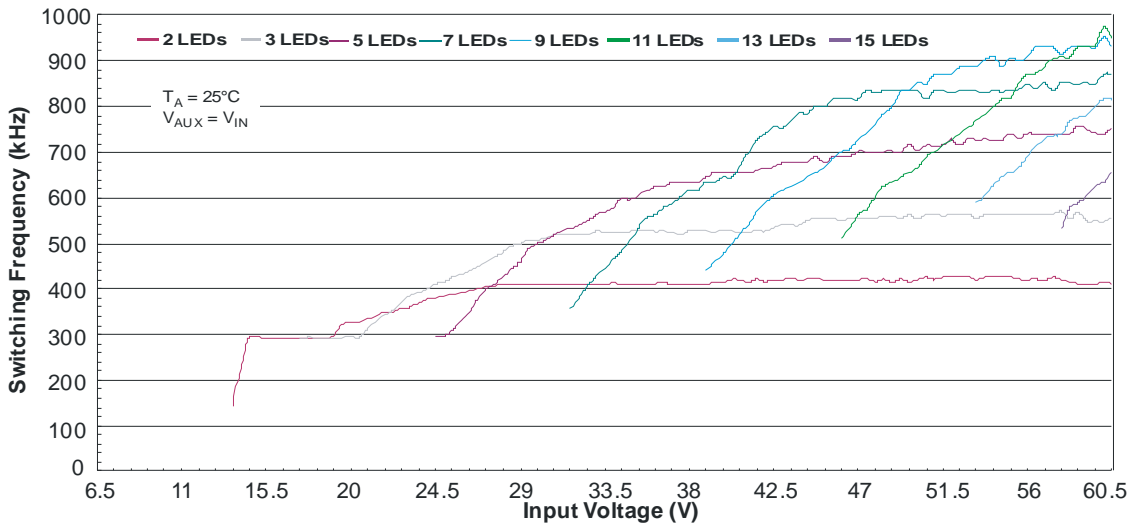
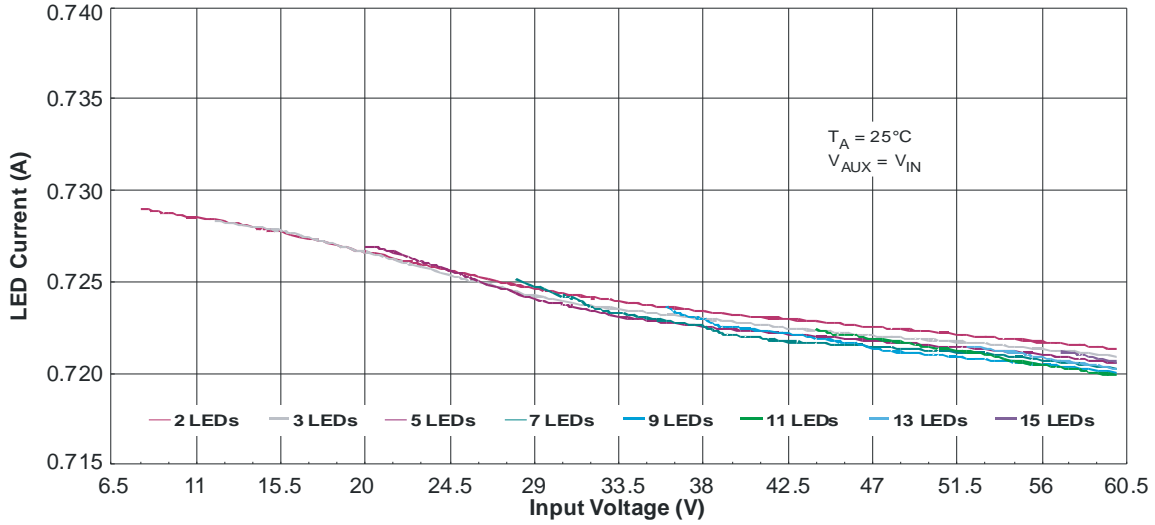

Figure 3: Efficiency vs. Input & Number of LED

Typical Characteristics – Buck Mode – $R_s = 300m\Omega$ - $L = 47\mu H$ - $I_{LED} = 750mA$



Typical Characteristics – Boost mode – $I_{LED} = 350mA$ – $R_S = 150m\Omega$ – $G_{RATIO} = 0.23$

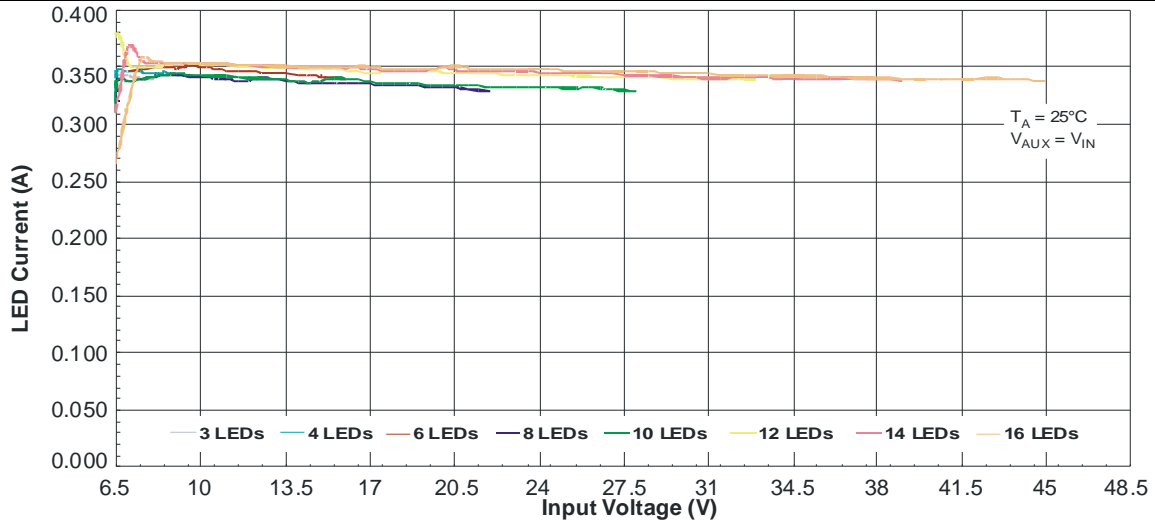

Figure 7: I_{LED} vs. Input Voltage & Number of LED

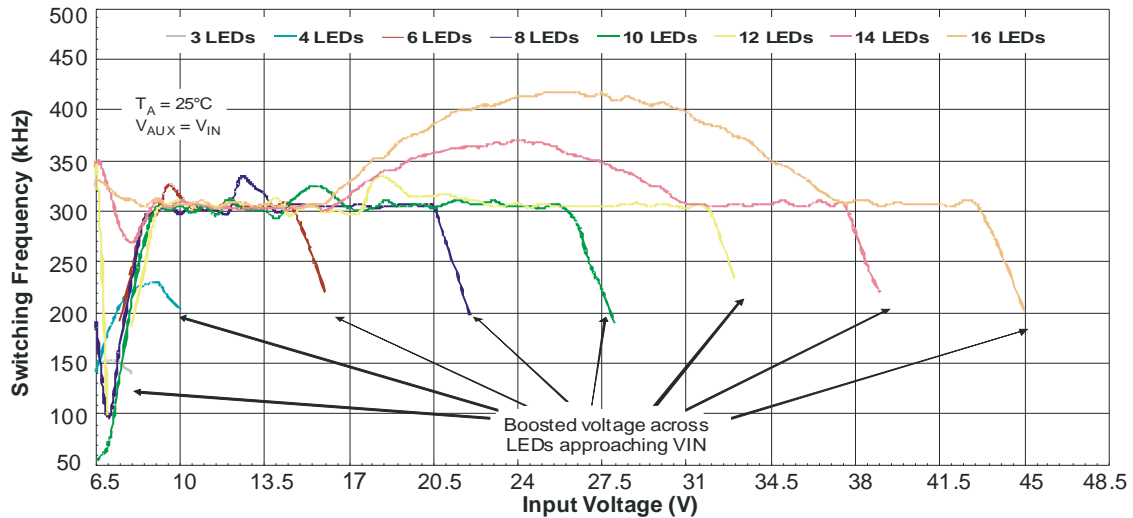

Figure 8: Frequency vs. Input Voltage & Number of LED

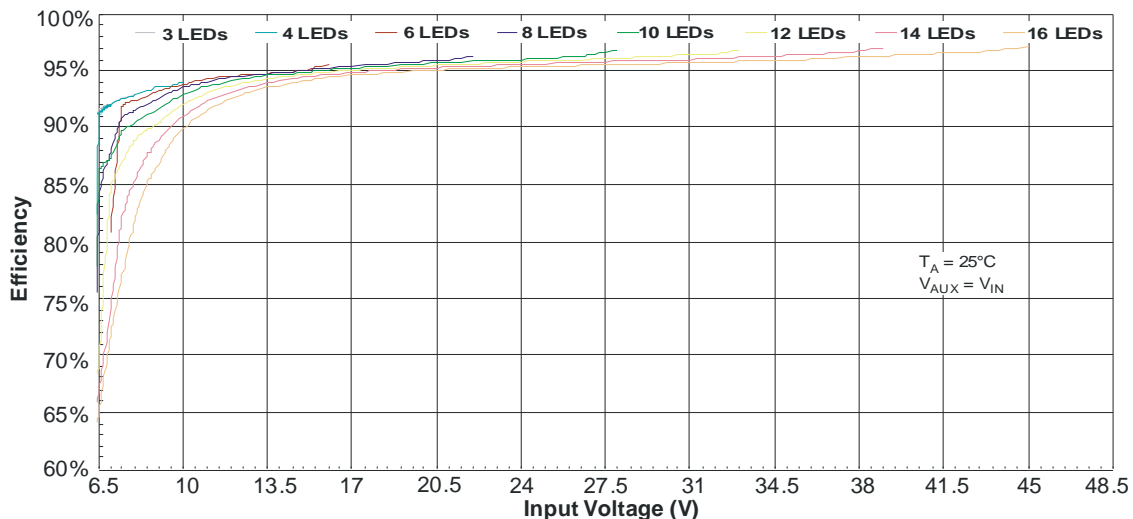

Figure 9: Efficiency vs. Input Voltage & Number of LED

Typical Characteristics – Buck-Boost mode – $R_S=150m\Omega$ - $I_{LED} = 350mA$ - $G_{RATIO} = 0.23$

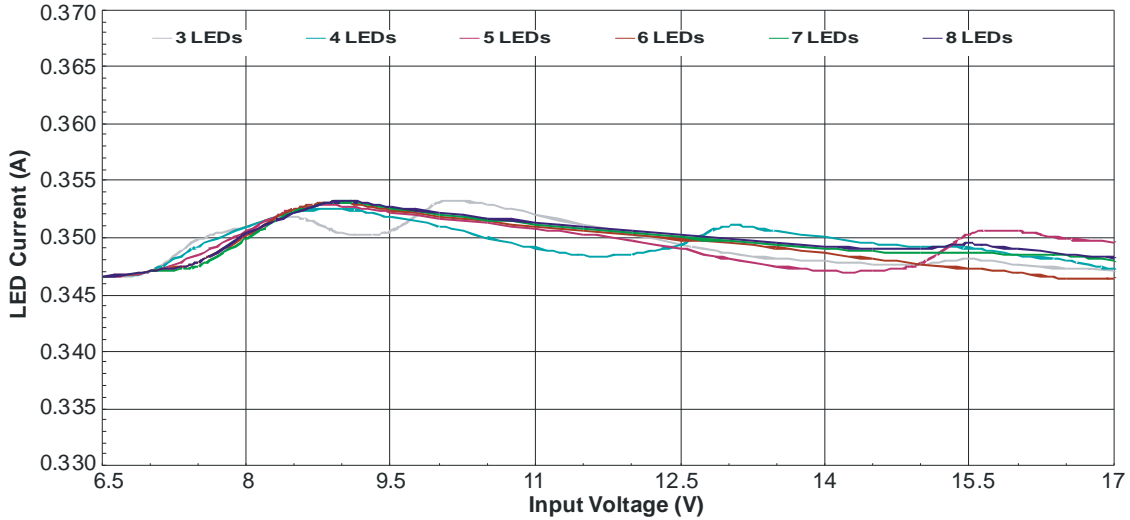

Figure 10: LED Current vs. Input Voltage & Number of LED

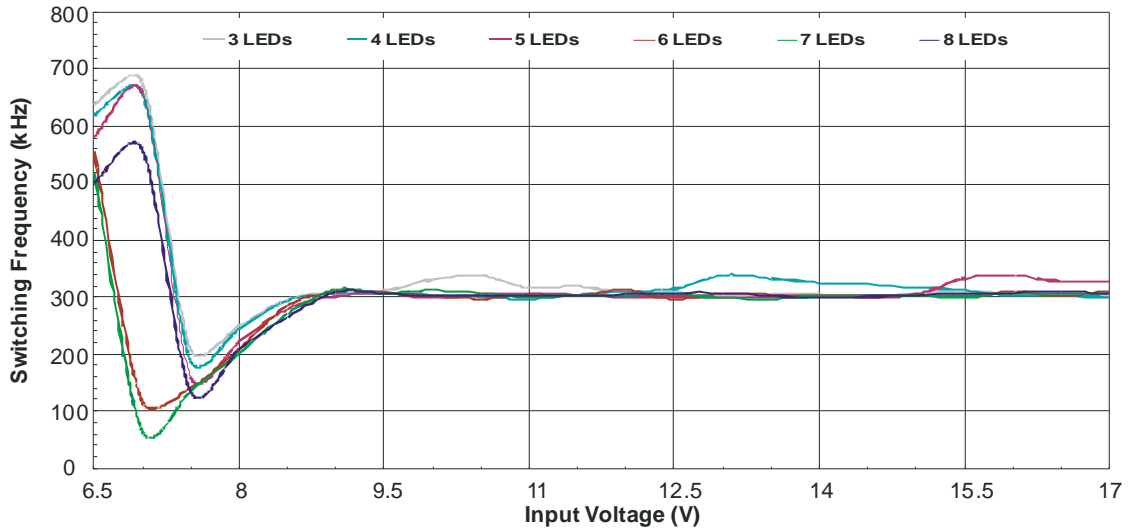

Figure 11: Switching Frequency vs. Input Voltage & Number of LED

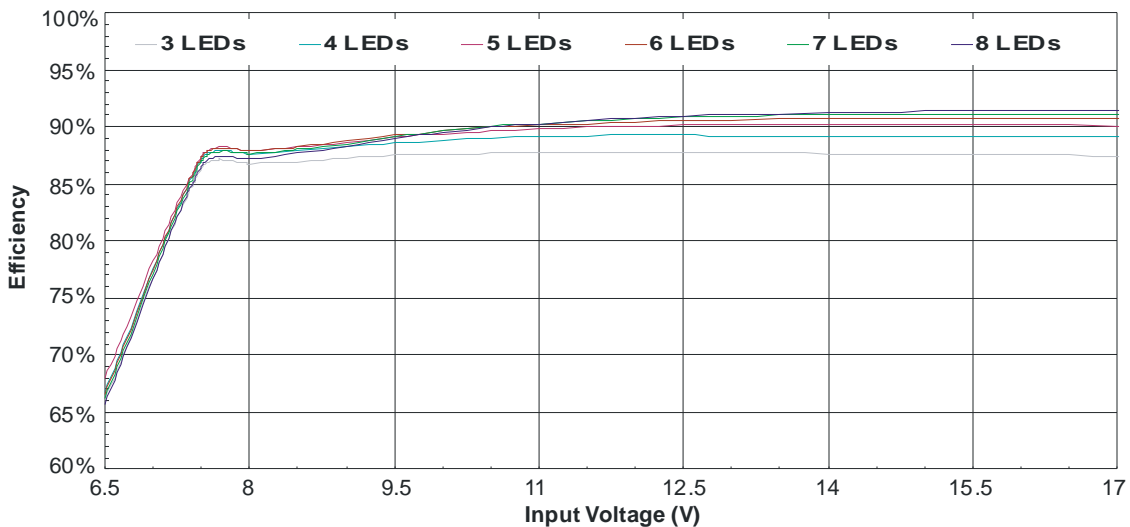

Figure 12: Efficiency vs. Input Voltage & Number of LED

Applications Information

The ZXLD1370 is a high accuracy hysteretic inductive buck/boost/buck-boost controller designed to be used with an external NMOS switch for current-driving single or multiple series-connected LEDs. The device can be configured to operate in buck, boost, or buck-boost modes by suitable configuration of the external components as shown in the schematics shown in the device operation description.

DEVICE OPERATION

a) Buck mode – the most simple buck circuit is shown in Figure 13

LED current control in buck mode is achieved by sensing the coil current in the sense resistor R_s , connected between the two inputs of a current monitor within the control loop block. An output from the control loop drives the input of a comparator which drives the gate of the external NMOS switch transistor M1 via the internal Gate Driver. When the switch is on, current flows from V_{IN} , via R_s , LED, coil and switch to ground. This current ramps up until an upper threshold value is reached. At this point GATE goes low, the switch is turned off and the current flows via R_s , LED, coil and D1 back to V_{IN} . When the coil current has ramped down to a lower threshold value, GATE goes high, the switch is turned on again and the cycle of events repeats, resulting in continuous oscillation.

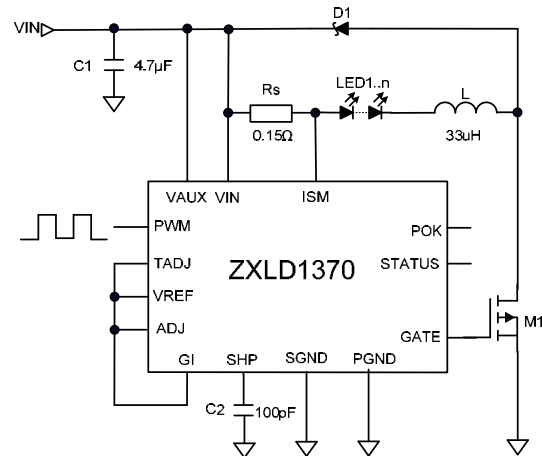

Figure 13: Buck configuration

The average current in the LED and coil is equal to the average of the maximum and minimum threshold currents. The ripple current (hysteresis) is equal to the difference between the thresholds. The control loop maintains the average LED current at the set level by adjusting the thresholds continuously to force the average current in the coil to the value demanded by the voltage on the ADJ pin. This minimizes variation in output current with changes in operating conditions. The control loop also attempts to minimize changes in switching frequency by varying the level of hysteresis. The hysteresis has a defined minimum (typ 5%) and a maximum (typ 30%), the frequency may deviate from nominal in extreme conditions. Loop compensation is achieved by a single external capacitor C2, connected between SHP and SGND.

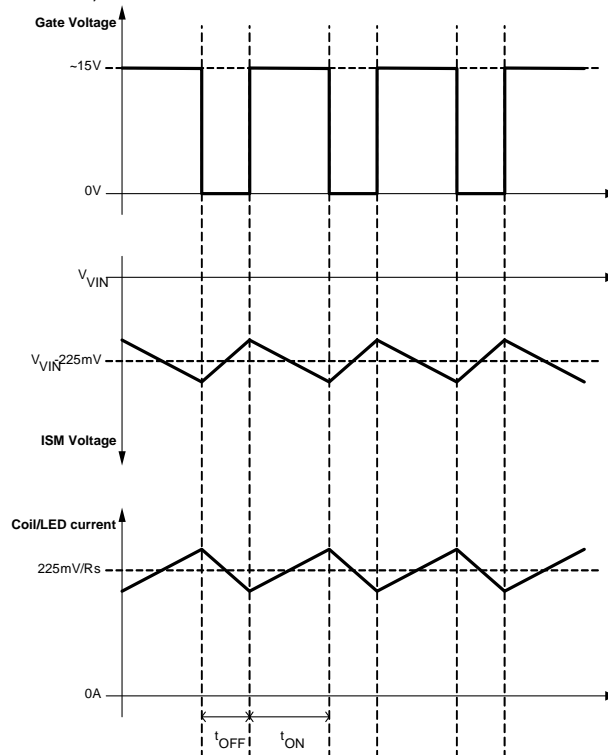

Figure 14: Operating waveforms (Buck mode)

b) Boost and Buck-Boost modes

Control in Boost and Buck-boost mode is achieved by sensing the coil current in the series resistor R_s , connected between the two inputs of a current monitor within the control loop block. An output from the control loop drives the input of a comparator which drives the gate of the external NMOS switch transistor M1 via the internal Gate Driver. In boost and buck-boost modes, when the switch is on, current flows from V_{IN} , via R_s , coil and switch to ground. This current ramps up until an upper threshold value is reached. At this point GATE goes low, the switch is turned off and the current flows via R_s , coil, D1 and LED back to V_{IN} (Buck-boost mode), or GND (Boost mode). When the coil current has ramped down to a lower threshold value, GATE goes high, the switch is turned on again and the cycle of events repeats, resulting in continuous oscillation. The average current in the coil is equal to the average of the maximum and minimum threshold currents and the ripple current (hysteresis) is equal to the difference between the thresholds.

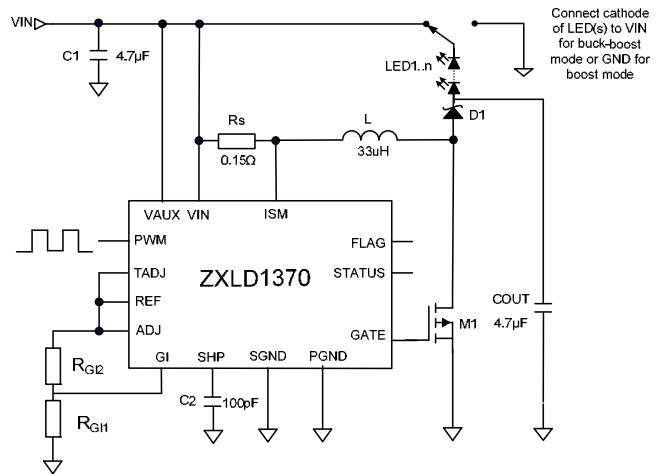

Figure 15: Boost and Buck-Boost configuration

The average current in the LED is always less than the average current in the coil and the ratio between these currents is set by the values of external resistors R_{G1} and R_{G2} . The peak LED current is equal to the peak coil current. The control loop maintains the average LED current at the set level by adjusting the thresholds and the hysteresis continuously to force the average current in the coil to the value demanded by the voltage on the ADJ and GI pins. This minimises variation in output current with changes in operating conditions. Loop compensation is achieved by a single external capacitor C2, connected between SHP and SGND.

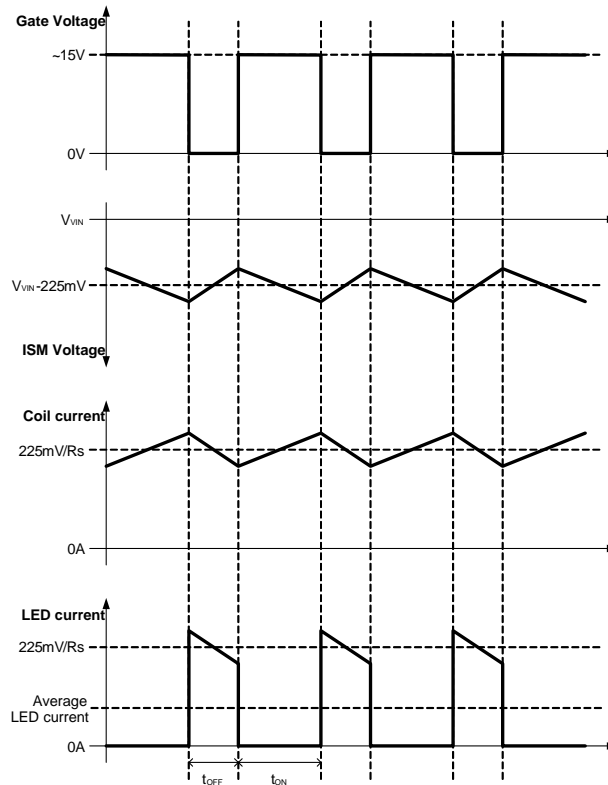

Figure 16 - Operating waveforms (Boost and Buck-boost modes)

Note: In Boost and Buck-boost modes, average $I_{LED} = \text{average } I_{COIL} \times R_{G1} / (R_{G1} + R_{G2})$

For more detailed descriptions of device operation and for choosing external components, please refer to the application circuits and descriptions in the later sections of this specification.

Application Information

A basic ZXLD1370 application circuit is shown in Figure 13 and 15.

External component selection is driven by the characteristics of the load and the input supply, since this will determine the kind of topology being used for the system.

Component selection starts with the current setting procedure, the inductor/frequency setting and the MOSFET selection. Finally after selecting the freewheeling diode and the output capacitor (if needed), the application section will cover the PWM dimming and thermal feedback.

Setting the output current

The first choice when defining the output current is whether the device is operating with the load in series with the sense resistor (buck mode) or whether the load is not in series with the sense resistor (boost and buck-boost modes).

The output current setting depends on the choice of the sense resistor R_s , the voltage on the ADJ pin and the voltage on the GI pin, according to the device working mode. The sense resistor R_s sets the coil current I_{RS} .

The ADJ pin may be connected directly to the internal 1.25V reference (V_{REF}) to define the nominal 100% LED current. The ADJ pin can also be overdriven with an external dc voltage between 125mV and 2.5V to adjust the LED current proportionally between 10% and 200% of the nominal value.

ADJ and GI are high impedance inputs within their normal operating voltage ranges. An internal 2.6V clamp protects the device against excessive input voltage and limits the maximum output current to approximately 4% above the maximum current set by V_{ADJ} if the maximum input voltage is exceeded.

Below are provided the details of the LED current calculation both when the load in series with the sense resistor (buck mode) and when the load is not in series with the sense resistor (boost and buck-boost modes).

In Buck mode, GI is connected to ADJ giving the ratio of average LED current (I_{LED}) to average sense resistor/coil current (I_{RS}).

$$I_{LED} = I_{RS} = \frac{225mV}{R_s} \frac{V_{ADJ}}{V_{REF}}$$

If the ADJ and GI pins are connected to V_{REF} directly, this becomes:

$$I_{LED} = I_{RS} = \frac{225mV}{R_s}$$

Therefore:

$$R_s = \frac{225mV}{I_{LED}}$$

In Boost and Buck-boost mode GI is connected to ADJ through a voltage divider.

With V_{ADJ} equal to V_{REF} , the ratio defined by the resistor divider at the GI pin determines the ratio of average LED current (I_{LED}) to average sense resistor/coil current (I_{RS}).

$$I_{LED} = \frac{V_{GI}}{V_{ADJ}} I_{RS} = \frac{R_{GI1}}{(R_{GI1} + R_{GI2})} I_{RS}$$

Where
$$I_{RS} = \frac{225mV}{R_s} \frac{V_{ADJ}}{V_{REF}}$$

When the ADJ pin is connected to V_{REF} directly, this becomes:

$$I_{RS} = \frac{225mV}{R_s}$$

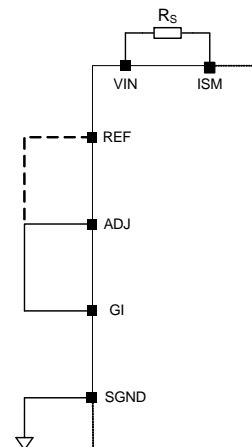

Figure 17: Buck configuration

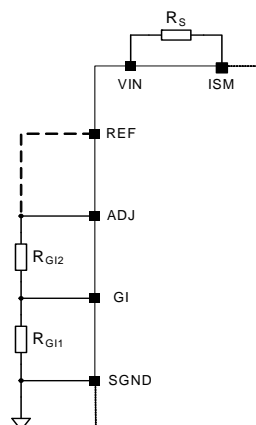

Figure 18: Boost and Buck-boost connection

Therefore:

$$R_s = \frac{R_{G1}}{(R_{G1} + R_{G2})} \frac{225mV}{I_{LED}}$$

Note that the average LED current for a boost or buck-boost converter is always less than the average sense resistor current. For the ZXLD1370, the recommended potential divider ratio is given by:

$$0.2 \leq \frac{R_{G1}}{(R_{G1} + R_{G2})} \leq 0.50$$

It is possible to use a different combination of GI pin voltages and sense resistor values to set the LED current.

In general the design procedure to follow is:

- Define input conditions in terms of V_{IN} and I_{IN}
- Set output conditions in terms of LED current and the number of LEDs
- Define controller topology – Buck, Boost or Buck-boost

Calculate the maximum duty-cycle as:

Buck mode

$$D_{MAX} = \frac{V_{LEDS}}{V_{INMIN}}$$

Boost mode

$$D_{MAX} = \frac{V_{LEDS} - V_{INMIN}}{V_{LEDS}}$$

Buck-boost mode

$$D_{MAX} = \frac{V_{LEDS}}{V_{LEDS} + V_{INMIN}}$$

Set the appropriate GI ratio according to the circuit duty and the max switch current admissible cycle limitations

$$\frac{V_{GI}}{V_{ADJ}} = \frac{R_{G1}}{(R_{G1} + R_{G2})} \leq 1 - D_{MAX}$$

- Set R_{G1} as: $10k\Omega \leq R_{G1} \leq 200k\Omega$
- Calculate R_{G2} as:

$$R_{G2} \approx \frac{D_{MAX}}{1 - D_{MAX}} \times R_{G1}$$

- Calculate the sense resistor as:

$$R_s = \frac{R_{G1}}{(R_{G1} + R_{G2})} \frac{225mV}{I_{LED}}$$

If the potential divider ratio is greater than 0.64, the device detects that buck-mode operation is desired and the output current will deviate from the desired value.

For example, as in the typical application circuit, in order to get $I_{LED} = 350mA$ with $I_{RS} = 1.5A$ the ratio has to be set as:

$$\frac{I_{LED}}{I_{RS}} = \frac{V_{GI}}{V_{ADJ}} = \frac{R_{G11}}{(R_{G11} + R_{G12})} \approx 0.23$$

Setting $R_{G11} = 33k\Omega$ it results

$$R_{G12} = R_{G11} \left(\frac{V_{ADJ}}{V_{GI}} - 1 \right) = 110k\Omega$$

This will result in:

$$R_s = \frac{R_{G11}}{(R_{G11} + R_{G12})} \frac{225mV}{I_{LED}} = 150m\Omega$$

Table 1 shows typical resistor values used to determine GI_{RATIO} with E24 series resistors

Table 1

GI ratio	RG11	RG2
0.2	30k Ω	120k Ω
0.25	33k Ω	100k Ω
0.3	39k Ω	91k Ω
0.35	30k Ω	56k Ω
0.4	100k Ω	150k Ω
0.45	51k Ω	62k Ω
0.5	30k Ω	30k Ω

INDUCTOR/FREQUENCY SELECTION

Recommended inductor values for the ZXLD1370 are in the range 22 μ H to 100 μ H. The chosen coil should have a saturation current higher than the peak sensed current and a continuous current rating above the required mean sensed current by at least 50%.

The inductor value should be chosen to maintain operating duty cycle and switch 'on'/'off' times within the recommended limits over the supply voltage and load current range.

The frequency compensation mechanism inside the chip tends to keep the frequency within the range 300kHz – 400kHz in most of the operating conditions. Nonetheless, the controller allows for higher frequencies when either the number of LEDs or the input voltage increases.

The graphs below can be used to select a recommended inductor to maintain the ZXLD1370 switching frequency within a predetermined range when used in different topologies.

Buck inductor selection:

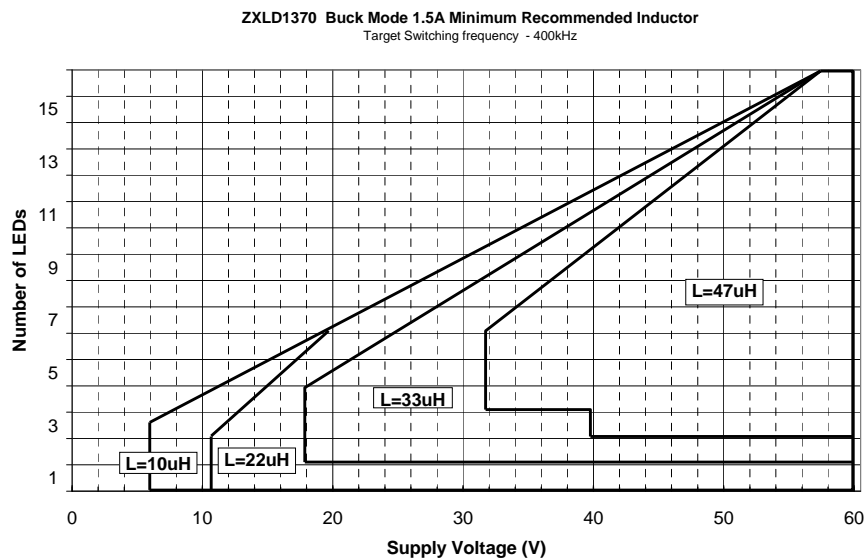

Figure 19: 1.5A Buck mode inductor selection for target frequency of 400 kHz

ZXLD1370 Buck Mode 1.5A Minimum Recommended Inductor
Target Switching frequency > 500kHz

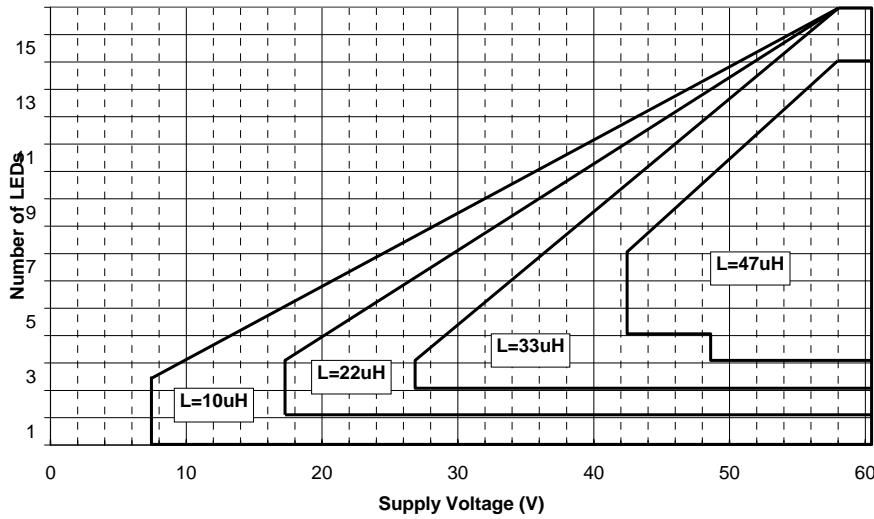

Figure 20: 1.5A Buck mode inductor selection for target frequency > 500kHz

For example, in a buck configuration ($V_{IN} = 24V$ and 6 LEDs), with a load current of 1.5A; if the target frequency is around 400 kHz, the Ideal inductor size is $L = 33\mu H$.

The same kind of graphs can be used to select the right inductor for a buck configuration and a LED current of 750mA, as shown in figures 21 and 22.

ZXLD1370 Buck Mode 750mA Minimum Recommended Inductor
Target Switching frequency 400kHz

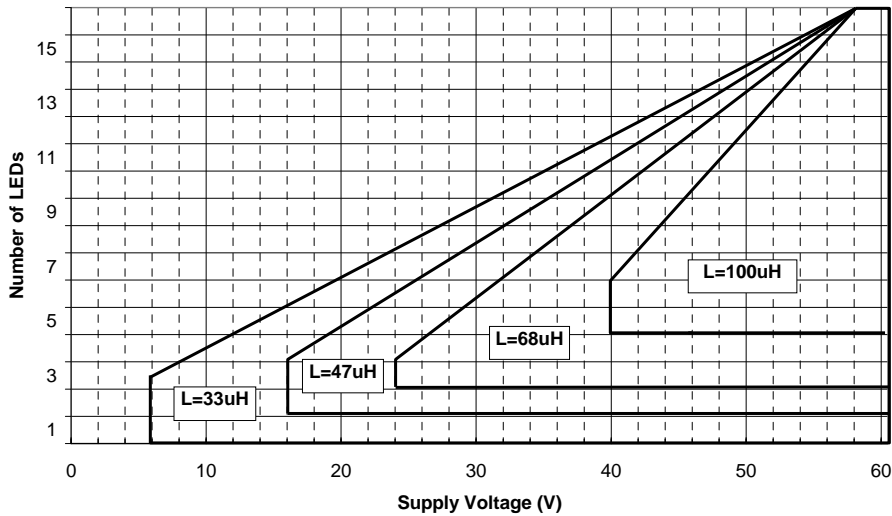

Figure 21: 750mA Buck mode inductor selection for target frequency 400kHz

ZXLD1370 Buck Mode 750mA Minimum Recommended Inductor
Target Switching frequency > 500kHz

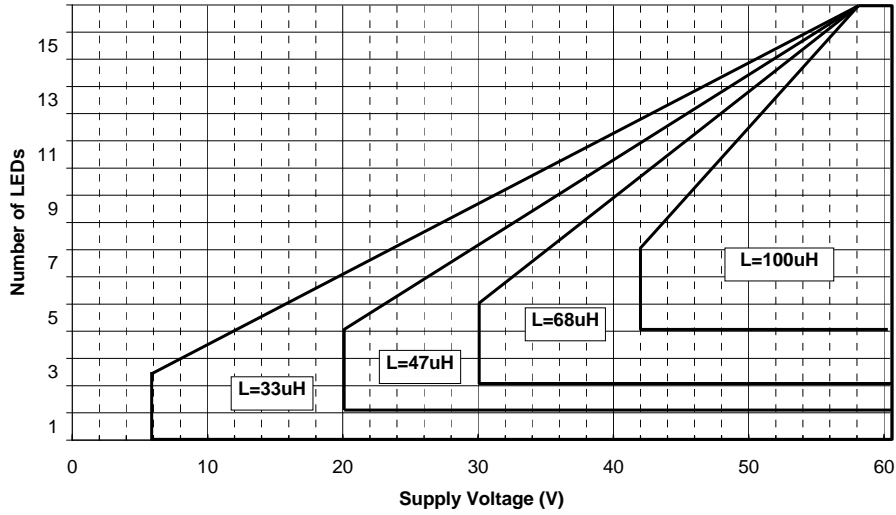

Figure 22: 750mA Buck mode inductor selection for target frequency > 500kHz

In the case of the Buck-boost topology, the following graphs guide the designer to select the inductor for a target frequency of 400kHz (figure 23) or higher than 500kHz (figure 24).

ZXLD1370 Buck-Boost Mode 350mA Minimum Recommended Inductor
Target Switching frequency - 400kHz

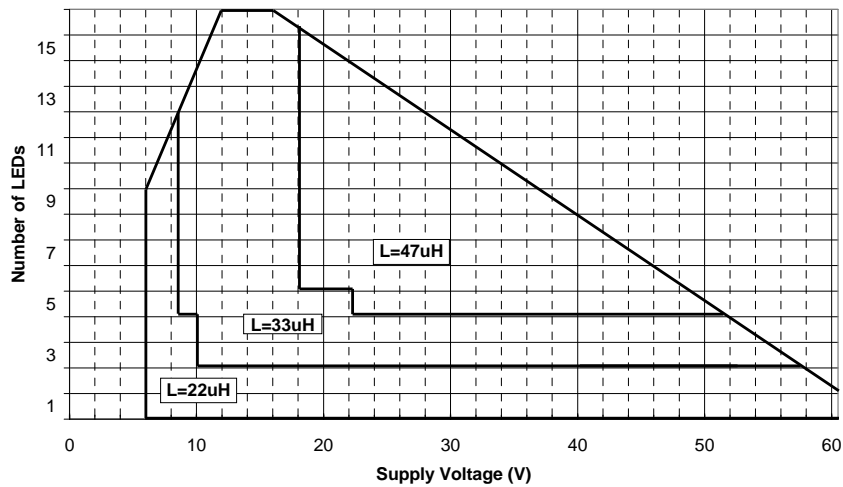

Figure 23: 350mA Buck-Boost mode inductor selection for target frequency 400kHz

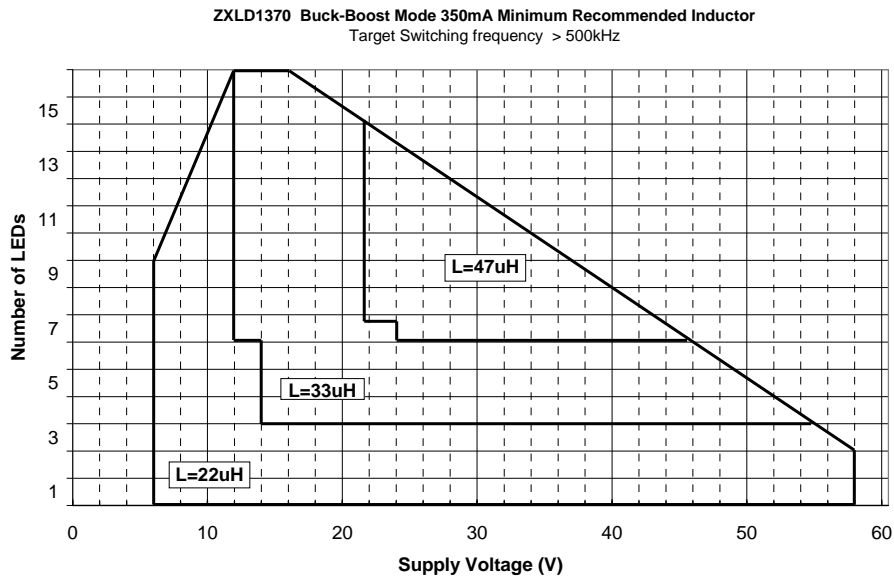

Figure 24: 350mA Buck-Boost mode inductor selection for target frequency > 500kHz

For example, in a Buck-bust configuration ($V_{IN} = 10-18V$ and 4 LEDs), with a load current of 350mA; if the target frequency is around 400kHz, the Ideal inductor size is $L = 33\mu H$. The same size of inductor can be used if the target frequency is higher than 500kHz driving 6LEDs with a current of 350mA from a $V_{IN} = 12-24V$.

In the case of the Boost topology, the following graphs guide the designer to select the inductor for a target frequency of 400kHz (figure 25) or higher than 500kHz (figure 26).

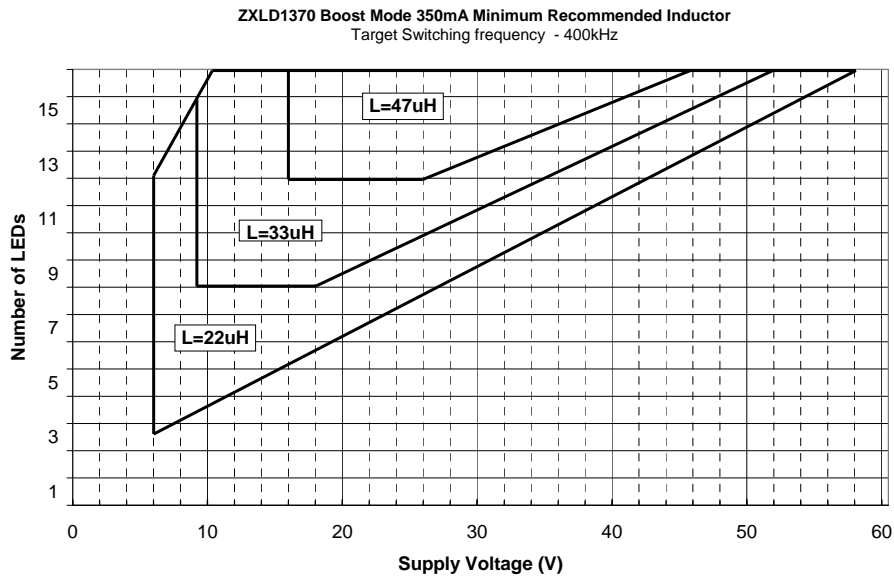

Figure 25: 350mA Boost mode inductor selection for target frequency 400kHz

ZXLD1370 Boost Mode 350mA Minimum Recommended Inductor
Target Switching frequency > 500kHz

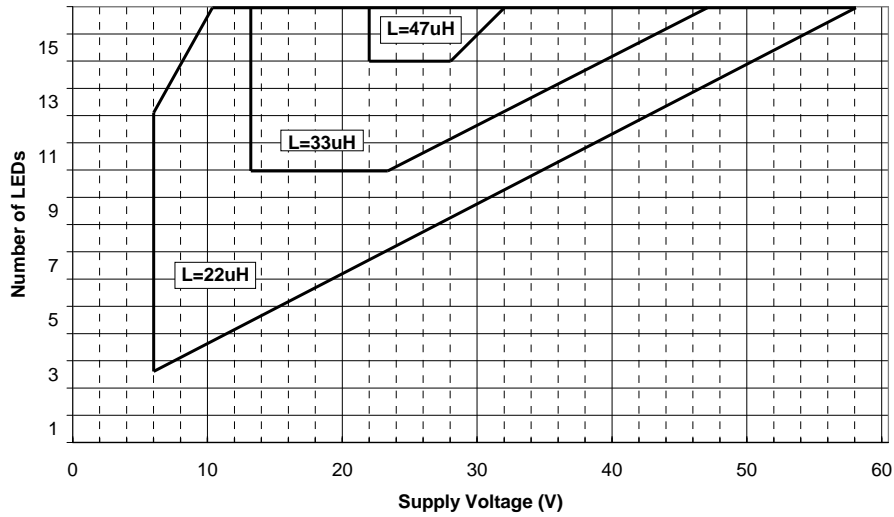

Figure 26: 350mA Buck-Boost mode inductor selection for target frequency > 500kHz

Suitable coils for use with the ZXLD1370 may be selected from the MSS range manufactured by Coilcraft, or the NPIS range manufactured by NIC components.

The following websites may be useful in finding suitable components

www.coilcraft.com

www.niccomp.com

www.wuerth-elektronik.de

MOSFET Selection

The ZXLD130 requires an external NMOS FET as the main power switch with a voltage rating at least 15% higher than the maximum transistor voltage to ensure safe operation during the ringing of the switch node. The current rating is recommended to be at least 10% higher than the average transistor current. The power rating is then verified by calculating the resistive and switching power losses.

$$P = P_{\text{resistive}} + P_{\text{switching}}$$

Resistive power losses

The resistive power losses are calculated using the RMS transistor current and the MOSFET on-resistance. Calculate the current for the different topologies as follows:

Buck mode

$$I_{\text{MOSFET-MAX}} = D_{\text{MAX}} \times I_{\text{LED}}$$

Boost / Buck-boost mode

$$I_{\text{MOSFET-MAX}} = \frac{D_{\text{MAX}}}{1 - D_{\text{MAX}}} \times I_{\text{LED}}$$

The approximate RMS current in the MOSFET will be:

Buck mode

$$I_{\text{MOSFET-RMS}} = I_{\text{LED}} \sqrt{D}$$

Boost / Buck-boost mode

$$I_{\text{MOSFET-RMS}} = \frac{\sqrt{D}}{1 - D} \times I_{\text{LED}}$$

The resistive power dissipation of the MOSFET is:

$$P_{\text{resistive}} = I_{\text{MOSFET-RMS}}^2 \times R_{\text{DS-ON}}$$

Switching power losses

Calculating the switching MOSFET's switching loss depends on many factors that influence both turn-on and turn-off. Using a first order rough approximation, the switching power dissipation of the MOSFET is:

$$P_{\text{switching}} = \frac{C_{\text{RSS}} \times V_{\text{IN}}^2 \times f_{\text{sw}} \times I_{\text{LOAD}}}{I_{\text{GATE}}}$$

where

C_{RSS} is the MOSFET's reverse-transfer capacitance (a data sheet parameter),

f_{sw} is the switching frequency,

I_{GATE} is the MOSFET gate-driver's sink/source current at the MOSFET's turn-on threshold.

Matching the MOSFET with the controller is primarily based on the rise and fall time of the gate voltage. The best rise/fall time in the application is based on many requirements, such as EMI (conducted and radiated), switching losses, lead/circuit inductance, switching frequency, etc. How fast a MOSFET can be turned on and off is related to how fast the gate capacitance of the MOSFET can be charged and discharged. The relationship between C (and the relative total gate charge Qg), turn-on/turn-off time and the MOSFET driver current rating can be written as:

$$dt = \frac{dV \cdot C}{I} = \frac{Qg}{I}$$

where

dt = turn-on/turn-off time

dV = gate voltage

C = gate capacitance = Qg/V

I = drive current – constant current source (for the given voltage value)

Here the constant current source "I" usually is approximated with the peak drive current at a given driver input voltage.

Example 1)

Using the DMN6068 MOSFET ($V_{\text{DS(MAX)}} = 60\text{V}$, $I_{\text{D(MAX)}} = 8.5\text{A}$):

$$\rightarrow Q_G = 10.3\text{nC at } V_{\text{GS}} = 10\text{V}$$

ZXLD1370 $I_{\text{PEAK}} = I_{\text{GATE}} = 300\text{mA}$

$$dt = \frac{Q_g}{I_{\text{PEAK}}} = \frac{10.3\text{nC}}{300\text{mA}} = 35\text{ns}$$

Assuming that cumulatively the rise time and fall time can account for a maximum of 10% of the period, the maximum frequency allowed in this condition is:

$$t_{\text{PERIOD}} = 20 \cdot dt \rightarrow f = 1/t_{\text{PERIOD}} = 1.43\text{MHz}$$

This frequency is well above the max frequency the device can handle, therefore the DNM6068 can be used with the ZXLD1370 in the whole spectrum of frequencies recommended for the device (from 300kHz to 1MHz).

Example 2)

Using the ZXMN6A09K ($V_{\text{DS(MAX)}} = 60\text{V}$, $I_{\text{D(MAX)}} = 12.2\text{A}$):

$$\rightarrow Q_G = 29\text{nC at } V_{\text{GS}} = 10\text{V}$$

ZXLD1370 $I_{\text{PEAK}} = 300\text{mA}$

$$dt = \frac{Q_g}{I_{\text{PEAK}}} = \frac{29\text{nC}}{300\text{mA}} = 97\text{ns}$$

Assuming that cumulatively the rise time and fall time can account for a maximum of 10% of the period, the maximum frequency allowed in this condition is:

$$t_{\text{PERIOD}} = 20 \cdot dt \rightarrow f = 1/t_{\text{PERIOD}} = 515\text{kHz}$$

This frequency is within the recommended frequency range the device can handle, therefore the ZXMN6A09K is recommended to be used with the ZXLD1370 for frequencies from 300kHz to 500kHz).

The recommended total gate charge for the MOSFET used in conjunction with the ZXLD1370 is less than 30nC.

Junction temperature estimation

Finally, the ZXLD1370 junction temperature can be estimated using the following equations:

Total supply current of ZXLD1370:

$$I_{Q_{TOT}} \approx I_Q + f \cdot Q_G$$

Where I_Q = total quiescent current $I_{Q-IN} + I_{Q-AUX}$

Power consumed by ZXLD1370

$$P_{IC} = V_{IN} \cdot (I_Q + f \cdot Q_G)$$

Or in case of separate voltage supply, with $V_{AUX} < 15V$

$$P_{IC} = V_{IN} \cdot I_{Q-IN} + V_{aux} \cdot (I_{Q-AUX} + f \cdot Q_G)$$

$$T_J = T_A + P_{IC} \cdot R_{TH(JA)}$$

$$T_A + P_{IC} \cdot (R_{TH(JC)} + R_{TH(CA)})$$

Where the total quiescent current $I_{Q_{TOT}}$ consists of the static supply current (I_Q) and the current required to charge and discharge the gate of the power MOSFET. Moreover the part of thermal resistance between case and ambient depends on the PCB characteristics.

DIODE SELECTION

For maximum efficiency and performance, the rectifier (D1) should be a fast low capacitance Schottky diode* with low reverse leakage at the maximum operating voltage and temperature. The Schottky diode also provides better efficiency than silicon PN diodes, due to a combination of lower forward voltage and reduced recovery time.

It is important to select parts with a peak current rating above the peak coil current and a continuous current rating higher than the maximum output load current. In particular, it is recommended to have a voltage rating at least 15% higher than the maximum transistor voltage to ensure safe operation during the ringing of the switch node and a current rating at least 10% higher than the average diode current. The power rating is verified by calculating the power loss through the diode.

The higher forward voltage and overshoot due to reverse recovery time in silicon diodes will increase the peak voltage on the Drain of the external MOSFET. If a silicon diode is used, care should be taken to ensure that the total voltage appearing on the Drain of the external MOSFET, including supply ripple, does not exceed the specified maximum value.

*A suitable Schottky diode would be PDS3100 (Diodes Inc).

OUTPUT CAPACITOR

An output capacitor may be required to limit interference or for specific EMC purposes. For boost and buck-boost regulators, the output capacitor provides energy to the load when the freewheeling diode is reverse biased during the first switching subinterval. An output capacitor in a buck topology will simply reduce the LED current ripple below the inductor current ripple. In other words, this capacitor changes the current waveform through the LED(s) from a triangular ramp to a more sinusoidal version without altering the mean current value.

In all cases, the output capacitor is chosen to provide a desired current ripple of the LED current (usually recommended to be less than 40% of the average LED current).

Buck:

$$C_{OUTPUT} = \frac{\Delta I_{L-PP}}{8 \times f_{SW} \times r_{LED} \times \Delta I_{LED-PP}}$$

Boost and Buck-boost

$$C_{OUTPUT} = \frac{D \times I_{LED-PP}}{f_{SW} \times r_{LED} \times \Delta I_{LED-PP}}$$

where:

- ΔI_L is the ripple of the inductor current, usually $\pm 20\%$ of the average sensed current
- ΔI_{LED} is the ripple of the LED current, it should be $<40\%$ of the LEDs average current
- f_{sw} is the switching frequency (From graphs and calculator)
- r_{LED} is the dynamic resistance of the LEDs string (n times the dynamic resistance of the single LED from the datasheet of the LED manufacturer).

The output capacitor should be chosen to account for derating due to temperature and operating voltage. It must also have the necessary RMS current rating. The minimum RMS current for the output capacitor is calculated as follows:

Buck

$$I_{\text{COUTPUT-RMS}} = \frac{I_{\text{LED-PP}}}{\sqrt{12}}$$

Boost and Buck-boost

$$I_{\text{COUTPUT-RMS}} = I_{\text{LED}} \sqrt{\frac{D_{\text{MAX}}}{1 - D_{\text{MAX}}}}$$

Ceramic capacitors with X7R dielectric are the best choice due to their high ripple current rating, long lifetime, and performance over the voltage and temperature ranges.

INPUT CAPACITOR

The input capacitor can be calculated knowing the input voltage ripple $\Delta V_{\text{IN-PP}}$ as follows:

Buck

$$C_{\text{IN}} = \frac{D \times (1 - D) \times I_{\text{LED}}}{f_{\text{SW}} \times \Delta V_{\text{IN-PP}}} \quad \text{Use } D = 0.5 \text{ as worst case}$$

Boost

$$C_{\text{IN}} = \frac{\Delta I_{\text{L-PP}}}{8 \times f_{\text{SW}} \times \Delta V_{\text{IN-PP}}}$$

Buck-boost

$$C_{\text{IN}} = \frac{D \times I_{\text{LED}}}{f_{\text{SW}} \times \Delta V_{\text{IN-PP}}} \quad \text{Use } D = D_{\text{MAX}} \text{ as worst case}$$

The minimum RMS current for the output capacitor is calculated as follows:

Buck

$$I_{\text{CIN-RMS}} = I_{\text{LED}} \times \sqrt{D \times (1 - D)} \quad \text{use } D=0.5 \text{ as worst case}$$

Boost

$$I_{\text{CIN-RMS}} = \frac{I_{\text{L-PP}}}{\sqrt{12}}$$

Buck-boost

$$I_{\text{CIN-RMS}} = I_{\text{LED}} \times \sqrt{\frac{D}{(1 - D)}} \quad \text{Use } D=D_{\text{MAX}} \text{ as worst case}$$

PWM OUTPUT CURRENT CONTROL & DIMMING

The ZXLD1370 has a dedicated PWM dimming input that allows a wide dimming frequency range from 100Hz to 1kHz with up to 1000:1 resolution; however higher dimming frequencies can be used – at the expense of dimming dynamic range and accuracy.

Typically, for a PWM frequency of 1kHz, the error on the current linearity is lower than 5%; in particular the accuracy is better than 1% for PWM from 5% to 100%. This is shown in the graph below:

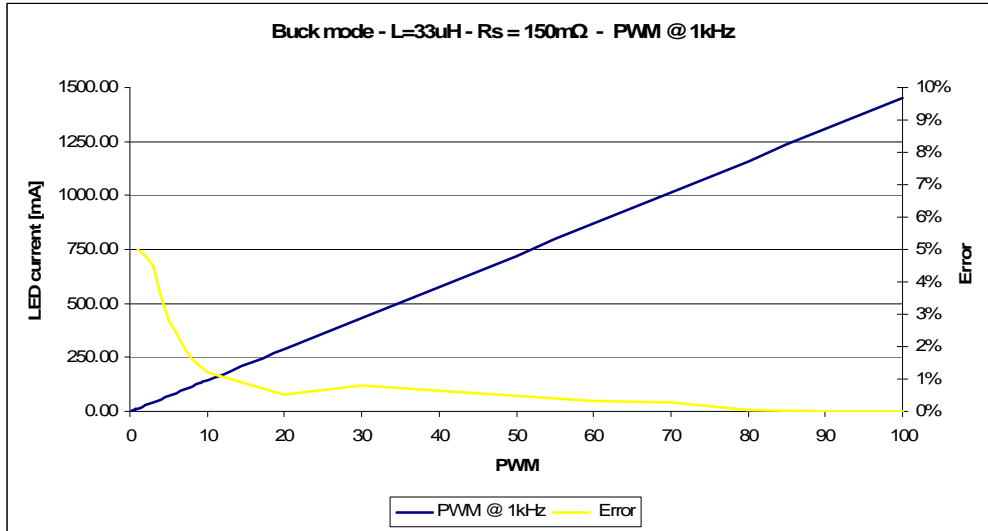

Figure 27: LED current linearity and accuracy with PWM dimming at 1kHz

For a PWM frequency of 100Hz, the error on the current linearity is lower than 2.5%; it becomes negligible for PWM greater than 5%. This is shown in the graph below:

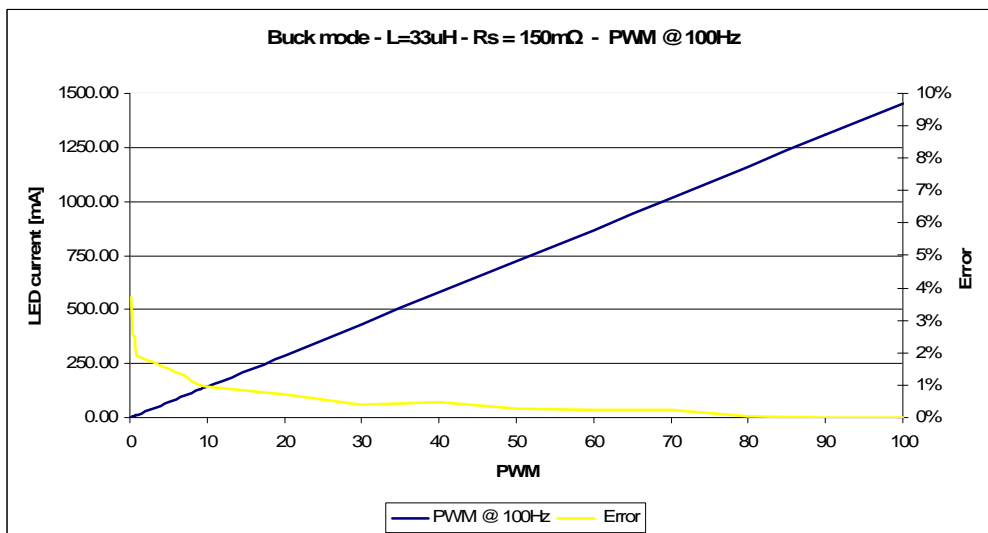

Figure 28: LED current linearity and accuracy with PWM dimming at 100Hz

The PWM pin is designed to be driven by both 3.3V and 5V logic levels. It can be driven also by an open drain/collector transistor. In this case the designer can either use the internal pull-up network or an external pull-up network in order to speed-up PWM transitions, as shown in the Boost/ Buck-Boost section.

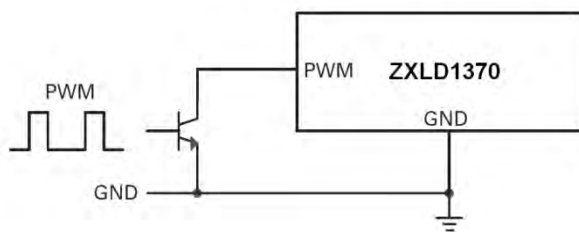

Figure 29: PWM dimming from open collector switch

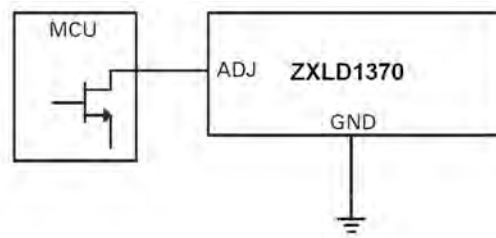

Figure 30: PWM dimming from MCU

LED current can be adjusted digitally, by applying a low frequency PWM logic signal to the PWM pin to turn the controller on and off. This will produce an average output current proportional to the duty cycle of the control signal. During PWM operation, the device remains powered up and only the output switch is gated by the control signal.

The PWM signal can achieve very high LED current resolution. In fact, dimming down from 100% to 0, a minimum pulse width of 2µs can be achieved resulting in very high accuracy. While the maximum recommended pulse is for the PWM signal is 10ms.

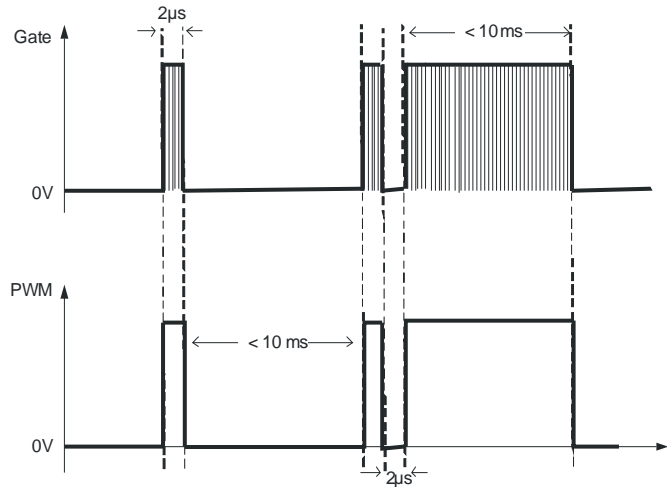

Figure 31: PWM dimming minimum and maximum pulse

The device can be put in standby by taking the PWM pin to ground, or pulling it to a voltage below 0.4V with a suitable open collector NPN or open drain NMOS transistor, for a time exceeding 15ms (nominal). In the shutdown state, most of the circuitry inside the device is switched off and residual quiescent current will be typically 90µA. In particular, the Status pin will go down to GND while the FLAG and REF pins will stay at their nominal values.

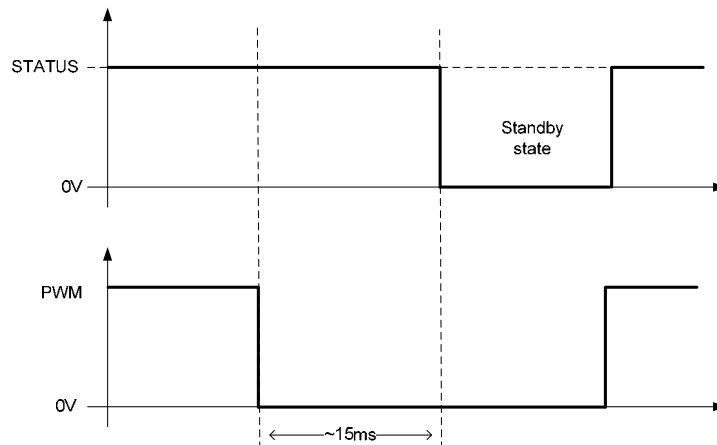

Fig 32: Stand-by state from PWM signal

TADJ pin - Thermal control of LED current

The 'Thermal control' circuit monitors the voltage on the TADJ pin and reduces output current if the voltage on this pin falls below 625mV. An external NTC thermistor and resistor can therefore be connected as shown below to set the voltage on the TADJ pin to 625mV at the required temperature threshold. This will give 100% LED current below the threshold temperature and a falling current above it as shown in the graph. The temperature threshold can be altered by adjusting the value of R_{th} and/or the thermistor to suit the requirements of the chosen LED.

The Thermal Control feature can be disabled by connecting TADJ to REF.

Here is a simple procedure to design the thermal feedback circuit:

- 1) Select the temperature threshold $T_{threshold}$ at which the current must start to decrease
- 2) Select the Thermistor TH1 (both resistive value at 25°C and beta)
- 3) Select the value of the resistor R_{th} as $R_{th} = TH$ at $T_{threshold}$

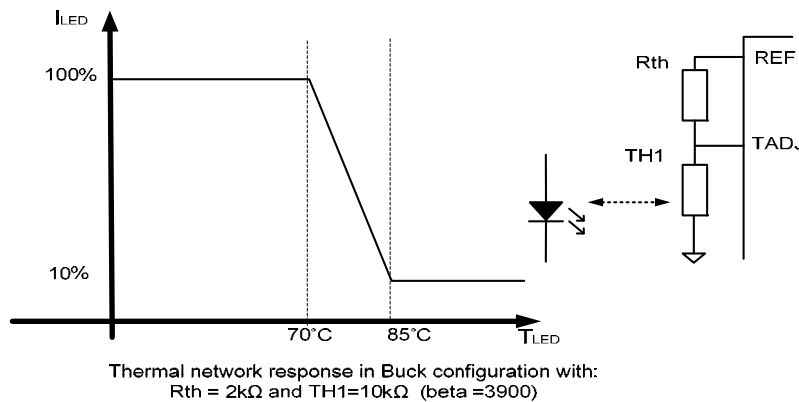

Figure 33: Thermal feedback network

For example,

- 1) Temperature threshold $T_{threshold} = 70^\circ\text{C}$
- 2) $TH1 = 10k\Omega$ at 25°C and $\beta = 3500 \rightarrow TH = 3.3k\Omega$ @ 70°C
- 3) $R_{th} = TH$ at $T_{threshold} = 3.3k\Omega$

Over-Temperature Shutdown

The ZXLD1370 incorporates an over-temperature shutdown circuit to protect against damage caused by excessive die temperature. A warning signal is generated on the STATUS output when die temperature exceeds 125°C nominal and the output is disabled when die temperature exceeds 150°C nominal. Normal operation resumes when the device cools back down to 125°C.

FLAG/STATUS Outputs

The FLAG/STATUS outputs provide a warning of extreme operating or fault conditions. FLAG is an open-drain logic output, which is normally off, but switches low to indicate that a warning, or fault condition exists. STATUS is a DAC output, which is normally high (4.5V), but switches to a lower voltage to indicate the nature of the warning/fault.

Conditions monitored, the method of detection and the nominal STATUS output voltage are given in the following table:

Table 2

Warning/Fault condition	Severity (Note 9)	Monitored parameters	FLAG	Nominal STATUS voltage
Normal operation			H	4.5
Supply under-voltage	1	$V_{AUX} < 5.6V$	L	4.5
	2	$V_{IN} < 5.6V$	L	3.6
Output current out of regulation (Note 10)	2	V_{SHP} outside normal voltage range	L	3.6
Driver stalled with switch 'on', or 'off' (Note 11)	2	t_{ON} , or $t_{OFF} > 100\mu s$	L	3.6
Device temperature above maximum recommended operating value	3	$T_J > 125^\circ C$	L	1.8
Sense resistor current I_{RS} above specified maximum	4	$V_{SENSE} > 0.32V$	L	0.9

- Notes:
- 9. Severity 1 denotes lowest severity.
 - 10. This warning will be indicated if the output power demand is higher than the available input power; the loop may not be able to maintain regulation.
 - 11. This warning will be indicated if the gate pin stays at the same level for greater than 100us (e.g. the output transistor cannot pass enough current to reach the upper switching threshold).

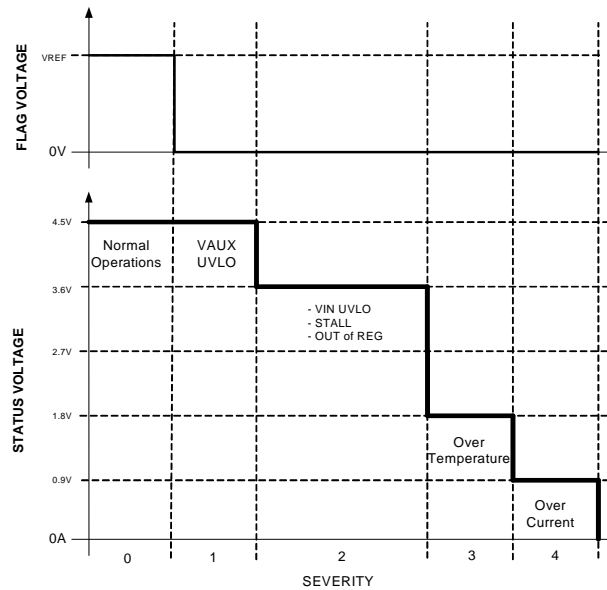

Fig 34: Status levels

In the event of more than one fault/warning condition occurring, the higher severity condition will take precedence. E.g. 'Excessive coil current' and 'Out of regulation' occurring together will produce an output of 0.9V on the STATUS pin.

If $V_{ADJ} > 1.7V$, V_{SENSE} may be greater than the excess coil current threshold in normal operation and an error will be reported. Hence, STATUS and FLAG are only guaranteed for $V_{ADJ} \leq V_{REF}$.

Diagnostic signals should be ignored during the device start – up for 100µs. The device start up sequence will be initiated both during the first power on of the device or after the PWM signal is kept low for more than 15ms, initiating the standby state of the device.

In particular, during the first 100µs the diagnostic is signaling an over-current then an out-of-regulation status. These two events are due to the charging of the inductor and are not true fault conditions.

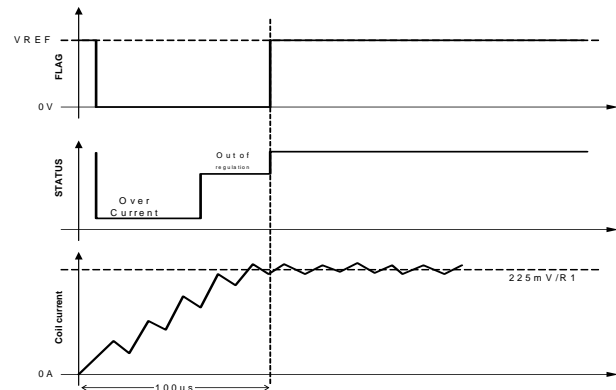

Fig 35: Diagnostic during Start-up

Boosting V_{AUX} supply voltage in Boost and Buck-Boost mode

When the input voltage is lower than 8V, the gate voltage will also be lower 8V. This means that depending on the characteristics of the external MOSFET, the gate voltage may not be enough to fully enhance the power MOSFET. This boosting technique is particularly important when the output MOSFET is operating at full current, since the boost circuit allows the gate voltage to be higher than 12V. This guarantees that the MOSFET is fully enhanced reducing both the power dissipation and the risk of thermal runaway of the MOSFET itself. An extra diode D2 and decoupling capacitor C3 can be used, as shown below in figure 36, to generate a boosted voltage at V_{AUX} when the input supply voltage at V_{IN} is below 8V. This enables the device to operate with full output current when V_{IN} is at the minimum value of 6V. In the case of a low voltage threshold MOSFET, the bootstrap circuit is generally not required.

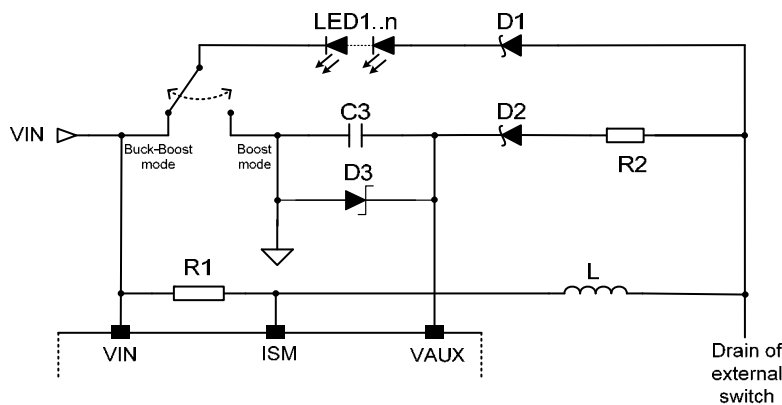

Fig 36: Bootstrap circuit for Boost and Buck-boost low voltage operations

The resistor R2 can be used to limit the current in the bootstrap circuit in order to reduce the impact of the circuit itself on the LED accuracy. The impact on the LED current is usually a decrease of maximum 5% compared to the nominal current value set by the sense resistor.

The Zener diode D3 is used to limit the voltage on the V_{AUX} pin to less than 60V.

Due to the increased number of components and the loss of current accuracy, the bootstrap circuit is recommended only when the system has to operate continuously in conditions of low input voltage (between 6 and 8V) and high load current. Other circumstances such as low input voltage at low load current, or transient low input voltage at high current should be evaluated keeping account of the external MOSFET power dissipation.

Over-voltage Protection

ZXLD1370

The ZXLD1370 is inherently protected against open-circuit load when used in Buck configuration. However care has to be taken with open-circuit load conditions in Buck-Boost or Boost configurations. This is because in these configurations there is no internal open-circuit protection mechanism for the external MOSFET. In this case an Over-Voltage-Protection (OVP) network should be provided externally to the MOSFET to avoid damage due to open circuit conditions. This is shown in **Figure 33** below, highlighted in the dotted blue box.

network should be provided externally to the MOSFET to avoid damage due to open circuit conditions. This is shown in **Figure 33** below, highlighted in the dotted blue box.

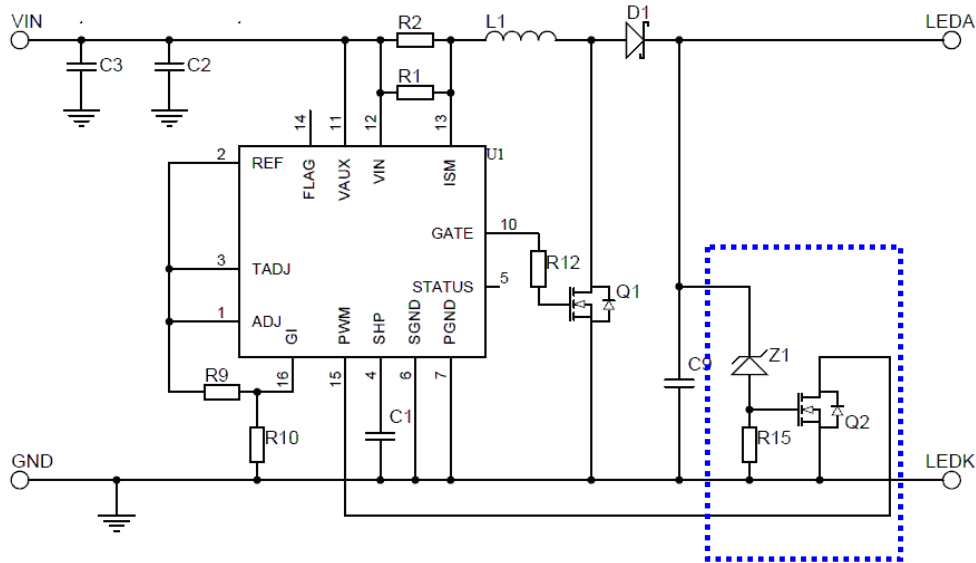

Fig 37: OVP circuit

The zener voltage is determined according to: $V_z = V_{LEDMAX} + 10\%$

Take care of the max voltage drop on the Q2 MOSFET gate.

PCB Layout considerations

PCB layout is a fundamental activity to get the most of the device in all configurations. In the following section it is possible to find some important insight to design with the ZXLD1370 both in Buck and Buck-Boost/Boost configurations.

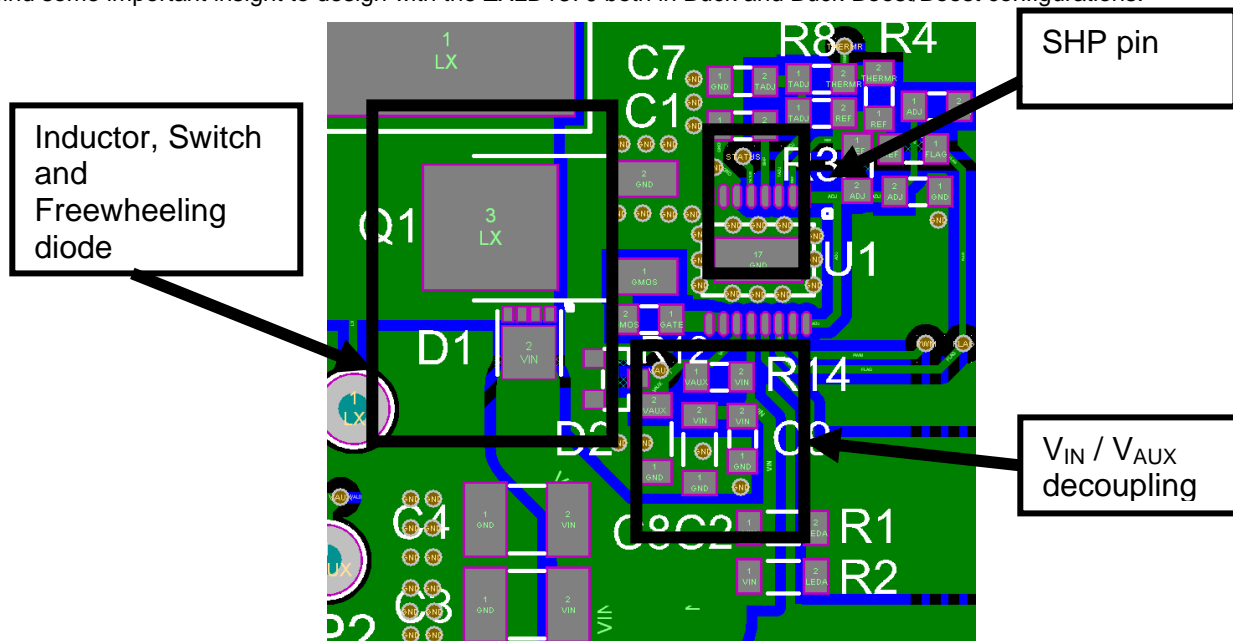

Figure 38: Circuit Layout

Here are some considerations useful for the PCB layout:

- In order to avoid ringing due to stray inductances, the inductor L1, the anode of D1 and the drain of Q1 should be placed as close together as possible.

ZXLD1370

- The shaping capacitor C1 is fundamental for the stability of the control loop. To this end it should be placed no more than 5mm from the SHP pin.
- Input voltage pins, VIN and VAUX, need to be decoupled. It is recommended to use two ceramic capacitors of 2.2uF, X7R, 100V (C3 and C4). In addition to these capacitors, it is suggested to add two ceramic capacitors of 1uF, X7R, 100V each (C2, C8), as well as a further decoupling capacitor of 100nF close to the VIN/VAUX pins (C9). VIN and VAUX pins can be short-circuited when the device is used in buck mode, or can be driven from a separate supply.

APPLICATION EXAMPLES

Example 1:

2.8A Buck LED driver

In this application example, the ZXLD1370 is connected as a buck LED driver. The schematic and parts list are shown below. The LED driver is able to deliver 2.8A of LED current with an input voltage range of 8V to 24V. In order to achieve high efficiency at high LED current, a Super Barrier Rectifier (SBR) with a low forward voltage is used as the free wheeling rectifier.

This LED driver is suitable for applications which require high LED current such as LED projector, automatic LED lighting etc.

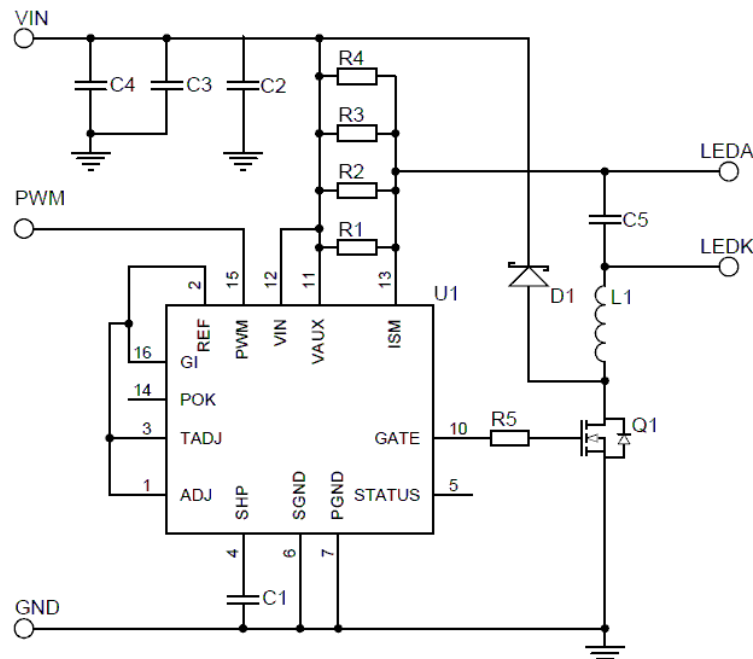

Figure 39: Application circuit: 2.8A Buck LED driver

Table 3: Bill of Material

Ref No.	Value	Part No.	Manufacturer
U1	60V LED driver	ZXLD1370	Diodes Inc
Q1	60V MOSFET	ZXMN6A09K	Diodes Inc
D1	45V 10A SBR	SBR10U45SP5	Diodes Inc
L1	33uH 4.2A	744770933	Würth Elektronik
C1	100pF 50V	SMD 0805/0603	Generic
C2	1uF 50V X7R	SMD1206	Generic
C3 C4 C5	4.7uF 50V X7R	SMD1210	Generic
R1 R2 R3	300mΩ 1%	SMD1206	Generic
R4	400mΩ 1%	SMD1206	Generic
R5	0Ω	SMD 0805/0603	Generic

Typical Performance

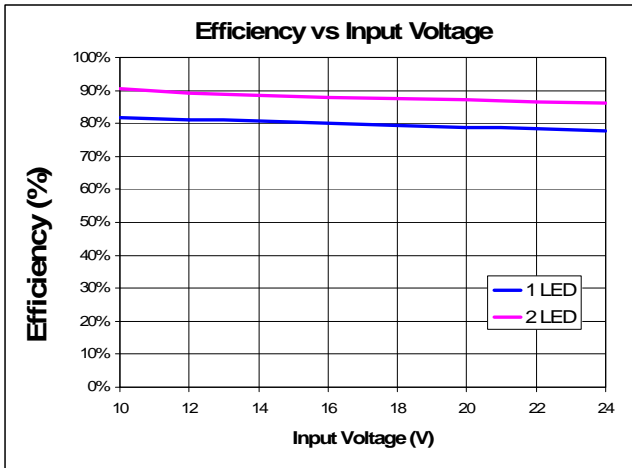

Figure 40: Efficiency

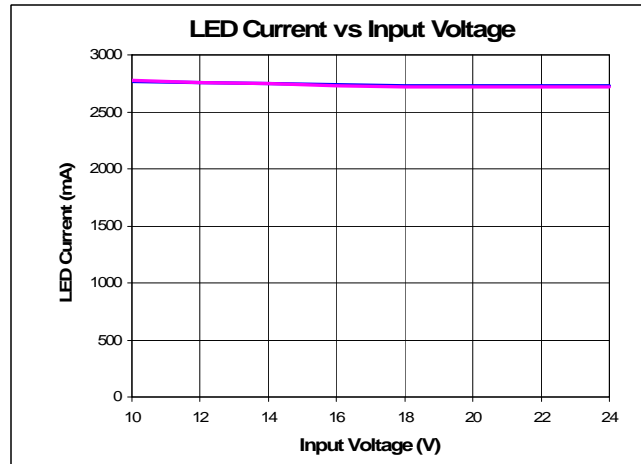

Figure 41: Line regulation

Example 2:

400mA Boost LED driver

In this application example, the ZXLD1370 is connected as a boost LED driver. The schematic and parts list are shown below. The LED driver is able to deliver 400mA of LED current into 12 high-brightness LEDs with an input voltage range of 16V to 32V.

The overall high efficiency of 92%+ makes it ideal for applications such as solar LED street lighting and general LED illuminations.

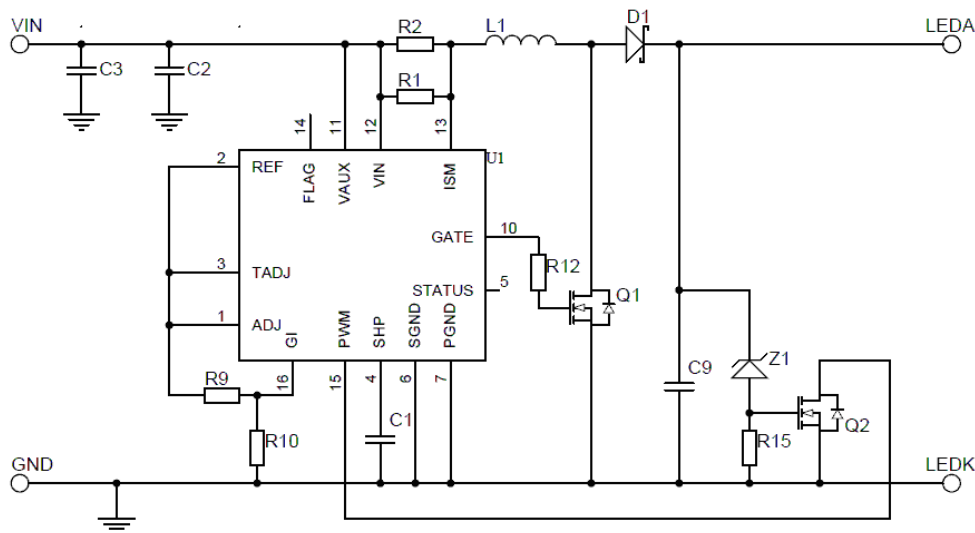

Figure 42: Application circuit - 400mA Boost LED driver

Table 4: Bill of Material

Ref No.	Value	Part No.	Manufacturer
U1	60V LED driver	ZXLD1370	Diodes Inc
Q1	60V MOSFET	ZXMN6A25G	Diodes Inc
Q2	60V MOSFET	2N7002A	Diodes Inc
D1	100V 3A Schottky	PDS3100-13	Diodes Inc
Z1	47V 410mW Zener	BZT52C47	Diodes Inc
L1	68uH 2.1A	744771168	Würth Elektronik
C1	100pF 50V	SMD 0805/0603	Generic
C3 C9	4.7uF 50V X7R	SMD1210	Generic
C2	1uF 50V X7R	SMD1206	Generic
R1 R2	560mΩ 1%	SMD1206	Generic
R9 R10	33KΩ 1%	SMD 0805/0603	Generic
R12	0Ω	SMD 0805/0603	Generic
R15	2.7KΩ	SMD 0805/0603	Generic

Typical Performance

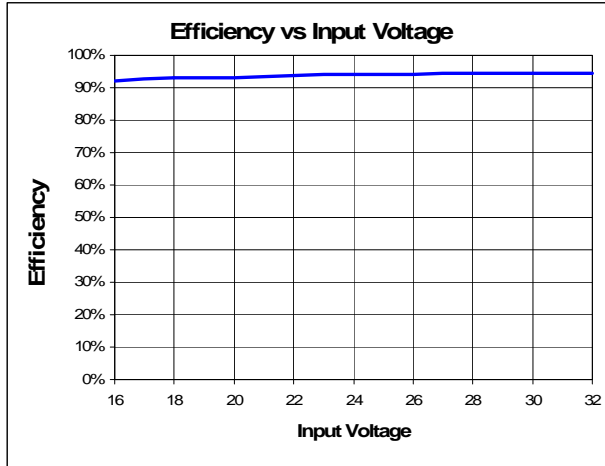

Figure 43: Efficiency

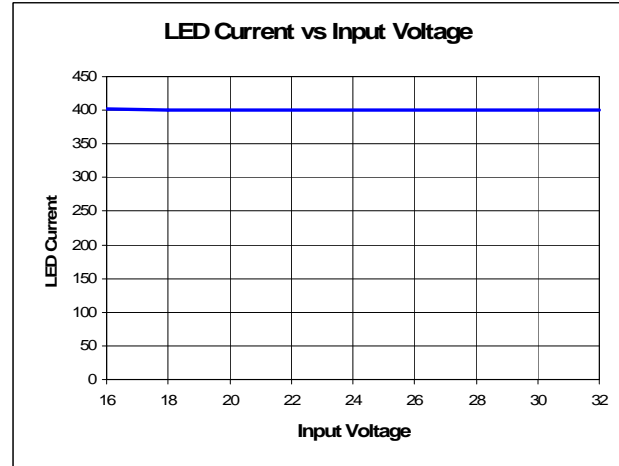

Figure 44: Line regulation

Example 3:

700mA Buck-Boost LED driver

In this application example, the ZXLD1370 is connected as a buck-boost LED driver. The schematic and parts list are shown below. The LED driver is able to deliver 700mA of LED current into 4 high-brightness LEDs with an input voltage range of 7V to 20V.

Since the Buck-boost LED driver handles an input voltage range from below and above the total LED voltage, the versatile input voltage range make it ideal for automotive lighting applications.

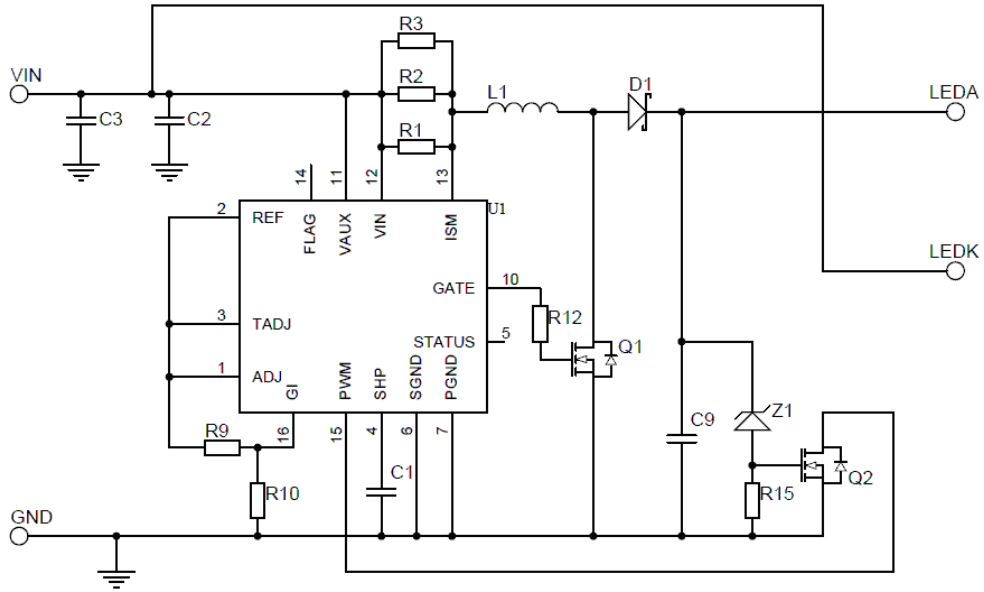

Figure 45: Application circuit - 700mA Buck-Boost LED driver

Table 5: Bill of Material

Ref No.	Value	Part No.	Manufacturer
U1	60V LED driver	ZXLD1370	Diodes Inc
Q1	60V MOSFET	ZXMN6A25G	Diodes Inc
Q2	60V MOSFET	2N7002A	Diodes Inc
D1	100V 5A Schottky	PDS5100-13	Diodes Inc
Z1	47V 410mW Zener	BZT52C47	Diodes Inc
L1	22uH 2.1A	744771122	Würth Elektronik
C1	100pF 50V	SMD 0805/0603	Generic
C3 C9	4.7uF 50V X7R	SMD1210	Generic
C2	1uF 50V X7R	SMD1206	Generic
R1 R2 R3	300mΩ 1%	SMD1206	Generic
R9	33KΩ 1%	SMD 0805/0603	Generic
R10	15KΩ 1%	SMD 0805/0603	Generic
R12	0Ω	SMD 0805/0603	Generic
R15	2.7KΩ	SMD 0805/0603	Generic

Typical Performance

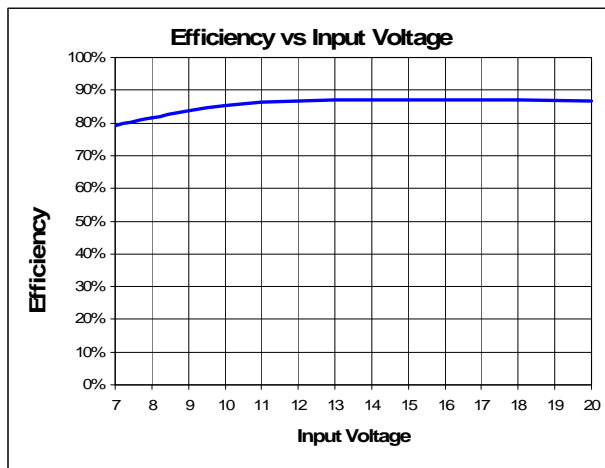

Figure 46: Efficiency

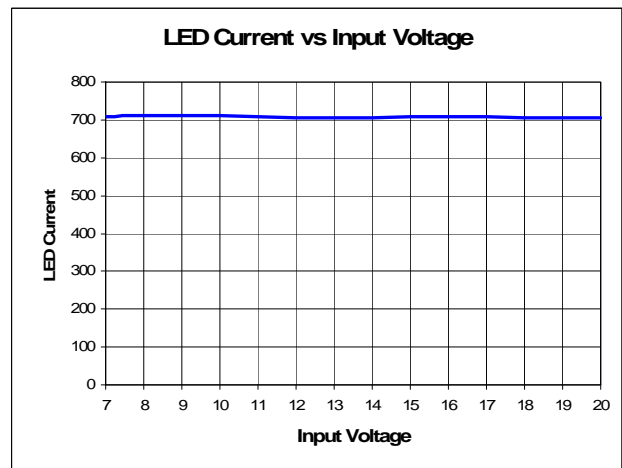

Figure 47: Line regulation

Ordering Information

Device	Packaging	Status	Part Marking	Reel Quantity	Tape Width	Reel Size
ZXLD1370EST16TC	TSSOP-16 EP	Active	ZXLD1370	2500	16mm	13"

Package Thermal Data

Thermal Resistance	Package	Value	Unit
Junction-to-Case, θ_{JC}	TSSOP-16 EP	23	$^{\circ}\text{C}/\text{W}$

Package Thermal Data

TSSOP-16 EP

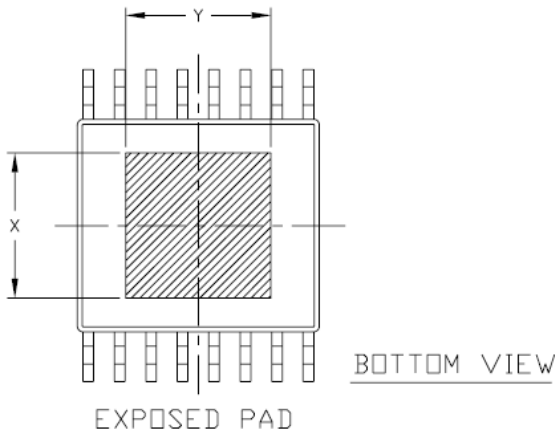
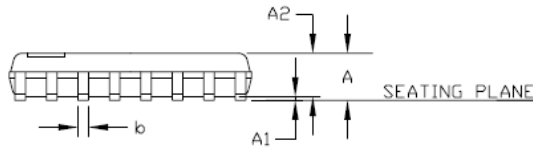
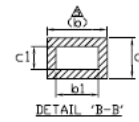
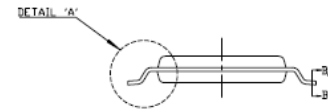
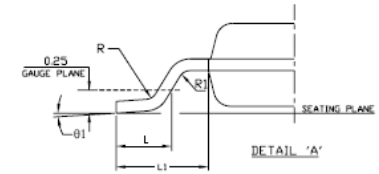
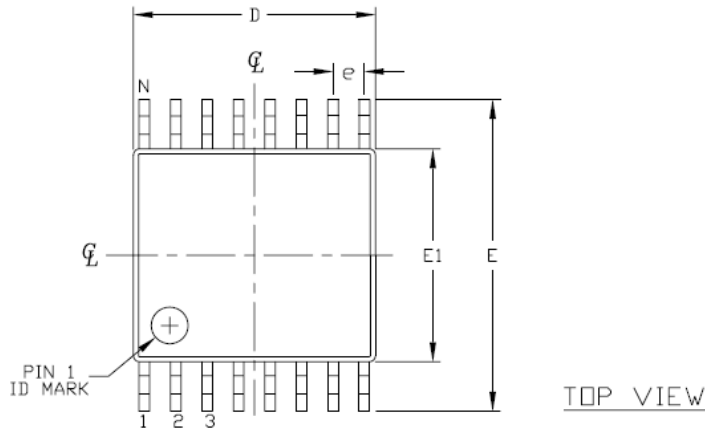

SYMBOL	16L TSSOP Thermally Enhanced		
	MIN	NOM.	MAX
A	—	—	1.20
A1	0.025	—	0.100
A2	0.80	0.90	1.05
D	4.9	5.0	5.1
E1	4.3	4.4	4.5
E	6.2	6.4	6.6
L	0.45	0.60	0.75
R	0.09	—	—
R1	0.09	—	—
b	0.19	—	0.30
b1	0.19	0.22	0.25
c	0.09	—	0.20
c1	0.09	—	0.16
$\theta 1$	0 $^{\circ}$	—	8 $^{\circ}$
L1	1.0 REF		
e	0.65 BSC		
N	16		
Ref.	Jedec MO-153 Issue C Variation ABT		
EP Area	Pad Size	X	Y
	Up 1	2,997	2,997

IMPORTANT NOTICE

DIODES INCORPORATED MAKES NO WARRANTY OF ANY KIND, EXPRESS OR IMPLIED, WITH REGARDS TO THIS DOCUMENT, INCLUDING, BUT NOT LIMITED TO, THE IMPLIED WARRANTIES OF MERCHANTABILITY AND FITNESS FOR A PARTICULAR PURPOSE (AND THEIR EQUIVALENTS UNDER THE LAWS OF ANY JURISDICTION).

Diodes Incorporated and its subsidiaries reserve the right to make modifications, enhancements, improvements, corrections or other changes without further notice to this document and any product described herein. Diodes Incorporated does not assume any liability arising out of the application or use of this document or any product described herein; neither does Diodes Incorporated convey any license under its patent or trademark rights, nor the rights of others. Any Customer or user of this document or products described herein in such applications shall assume all risks of such use and will agree to hold Diodes Incorporated and all the companies whose products are represented on Diodes Incorporated website, harmless against all damages.

Diodes Incorporated does not warrant or accept any liability whatsoever in respect of any products purchased through unauthorized sales channel.

Should Customers purchase or use Diodes Incorporated products for any unintended or unauthorized application, Customers shall indemnify and hold Diodes Incorporated and its representatives harmless against all claims, damages, expenses, and attorney fees arising out of, directly or indirectly, any claim of personal injury or death associated with such unintended or unauthorized application.

Products described herein may be covered by one or more United States, international or foreign patents pending. Product names and markings noted herein may also be covered by one or more United States, international or foreign trademarks.

LIFE SUPPORT

Diodes Incorporated products are specifically not authorized for use as critical components in life support devices or systems without the express written approval of the Chief Executive Officer of Diodes Incorporated. As used herein:

A. Life support devices or systems are devices or systems which:

1. are intended to implant into the body, or
2. support or sustain life and whose failure to perform when properly used in accordance with instructions for use provided in the labeling can be reasonably expected to result in significant injury to the user.

B. A critical component is any component in a life support device or system whose failure to perform can be reasonably expected to cause the failure of the life support device or to affect its safety or effectiveness.

Customers represent that they have all necessary expertise in the safety and regulatory ramifications of their life support devices or systems, and acknowledge and agree that they are solely responsible for all legal, regulatory and safety-related requirements concerning their products and any use of Diodes Incorporated products in such safety-critical, life support devices or systems, notwithstanding any devices- or systems-related information or support that may be provided by Diodes Incorporated. Further, Customers must fully indemnify Diodes Incorporated and its representatives against any damages arising out of the use of Diodes Incorporated products in such safety-critical, life support devices or systems.

Copyright © 2010, Diodes Incorporated

www.diodes.com