

---

## ZXLD1321

# Boost mode DC-DC converter for LED driving with 1A output and current control

---

### Description

The ZXLD1321 is an inductive DC-DC converter, with an internal switch, designed for driving single or multiple LEDs in series up to a total of 1A output current.

Applications cover commercial environments with input voltages ranging from 1.2V to 12V.

The device employs a variable 'on' and 'off' time control scheme with adjustable peak switch current limiting and supports step-up (Boost) mode and self-powering Bootstrap operating modes, offering higher power efficiency and lower system cost than conventional PFM circuitry.

The device includes the DC-DC converter, a high-side current monitor and an NPN switching transistor to provide an integrated solution offering small PCB size, competitive cost/performance, high power efficiency of DC-DC conversion and maximum LED brightness/reliability. More importantly, it retains design flexibility to add customer specific features.

The feedback control circuitry inside the ZXLD1321 provides excellent load and current regulation, resulting in very stable LED current over the useful life of the battery and over the full operating temperature range.

The LED current can be adjusted from 100% down to 10% of the set value by applying a dc voltage to the ADJ pin and down to 1% by applying a PWM signal to the ADJ pin. An on-chip LED protection circuit also allows output current to be reduced linearly above a predetermined threshold temperature using an external thermistor at the TADJ pin.

External resistors set nominal average LED current and coil peak current independently.

The device can be shut down by applying a continuous low level dc voltage to the ADJ pin.

### Features

- 1.2V to 12V Input voltage range
- Up to 1A output current
- Typical efficiency<sup>#</sup> >85%
- Bootstrap operation enables input voltage down to 1V
- User-defined thermal control of LED output current using external thermistor
- High output current stability over input voltage and temperature
- 12 $\mu$ A typical standby current
- LED current adjustable from 100% down to 2%
- Adjustable soft-start
- Drives up to 5 white LEDs in series

### Applications

- High power LED flashlights
- LED back-up lighting
- General LED lighting
- Emergency lighting

Note<sup>#</sup> : Using standard external components as specified under electrical characteristics. Efficiency is dependent upon external component types and values. Higher efficiency is possible with alternative coils.

# ZXLD1321

## Pin connections (top-view)

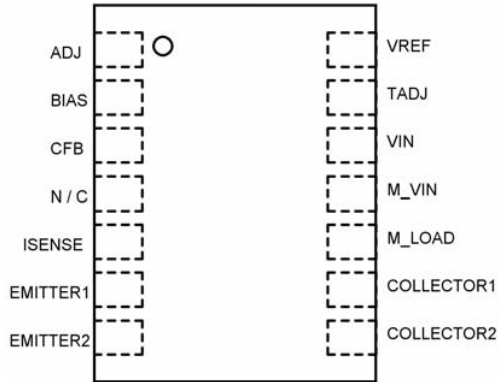

## Package view

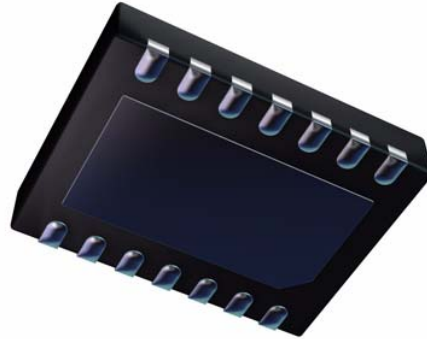

**Package**  
**14-Pin DFN with exposed pad**  
**4mm x 3mm**  
**0.50mm pitch**  
**1.5W @ $T_A=70^\circ\text{C}$**

**DFN14 package (bottom view).**  
**45° chamfer denotes Pin 1**

## Block diagram

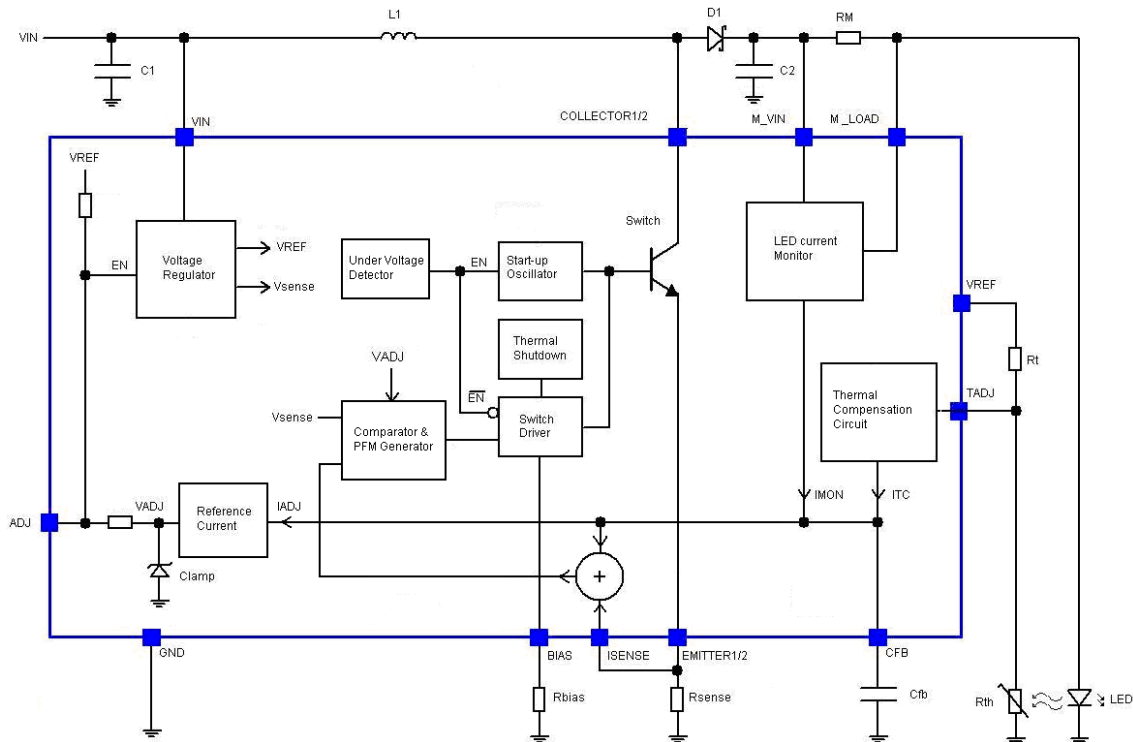

ZXLD1321 Block Diagram (showing external components)

## Absolute maximum ratings

(Voltages relative to GND unless otherwise stated)

Operating temperature (top)	-40 to 125°C
Storage temperature (Tst)	-55 to 150°C
Junction temperature (Tj)	-40 to 150°C
Package power dissipation (Ptot) DFN-14 with exposed pad: 4mmx3mm, 0.5mm Pitch	1.5W at Tamb = 70°C

### DC-DC converter

Supply voltage (VIN)	-0.3V to +12V
ADJ	-0.3V to The lower of (+5.0V) or (VIN + 0.3V)
CFB	-0.3V to The lower of (+5.0V) or (VIN + 0.3V)
ISENSE	-0.3V to The lower of (+5.0V) or (VIN + 0.3V)
TADJ	-0.3V to The lower of (+5.0V) or (VIN + 0.3V)
BIAS	-0.3V to The lower of (+5.0V) or (VIN + 0.3V)

### High-side current monitor

Monitor supply voltage (M_VIN)	-0.3V to +18V
Continuous sense voltage (M_VIN – M_LOAD)	-0.3V to +5V

### Switching NPN transistor

Collector-Base voltage (V <sub>CBO</sub> )	18V
Collector-Emitter voltage (V <sub>CEO</sub> )	18V
Peak pulse current (I <sub>CM</sub> )	3A (Pulse width = 300µs. Duty cycle ≤ 2%)
Continuous Collector current (I <sub>C</sub> )	2A

These are stress ratings only. Operation outside the absolute maximum ratings may cause device failure. Operation at the absolute maximum ratings for extended periods may reduce device reliability.

### Thermal resistance

Junction to case (R <sub>θJC</sub> )	Nominal value
DFN-14	26.3°C/W

## Pin description

Name	Pin #	Description
<b>ADJ</b>	<b>1</b>	Adjust input <ul style="list-style-type: none"> <li>• Leave floating, or connect to VREF to set 100% output current.</li> <li>• Drive with dc voltage. (<math>50\text{mV} &lt; V_{\text{ADJ}} &lt; V_{\text{REF}}</math>) to adjust output current from 10% to 100% of set value. (DC brightness control mode)</li> <li>• Drive with low frequency (200Hz) PWM control signal to gate output 'on' and 'off' at the PWM frequency. (PWM brightness control mode)</li> <li>• Drive with low level dc voltage (<math>V_{\text{ADJ}} &lt; 28\text{mV}</math>) to turn off device (Standby mode)</li> </ul>
<b>BIAS</b>	<b>2</b>	Bias pin for setting base current of internal switch transistor <ul style="list-style-type: none"> <li>• Short pin to ground to define maximum base drive current for output switch (Maximum output current condition)</li> <li>• Connect resistor (<math>R_{\text{BIAS}}</math>) from this pin to ground to reduce base drive current (Reduced output current condition)</li> </ul>
<b>CFB</b>	<b>3</b>	Compensation point <ul style="list-style-type: none"> <li>• Connect 10nF capacitor from this pin to ground to provide loop compensation</li> </ul>
<b>N/C</b>	<b>4</b>	No connection to this pin (open circuit)
<b>ISENSE</b>	<b>5</b>	Switch peak current sense pin <ul style="list-style-type: none"> <li>• Connect resistor (<math>R_{\text{SENSE}}</math>) from this pin to ground to define peak switch current (<math>I_{\text{SW\_PEAK}} = V_{\text{SENSE}} / R_{\text{SENSE}}</math>)</li> </ul>
<b>EMITTER</b>	<b>6, 7</b>	Switch emitters (connect both pins to top of $R_{\text{SENSE}}$ to sense emitter current)
<b>COLLECTOR</b>	<b>8, 9</b>	Switch collectors (connect both pins to lower side of coil)
<b>M_LOAD</b>	<b>10</b>	Load side input of high side current monitor
<b>M_VIN</b>	<b>11</b>	Input supply to high side current monitor <ul style="list-style-type: none"> <li>• Connect to output voltage (cathode of Schottky)</li> <li>• Connect resistor (<math>R_{\text{M}}</math>) between M_LOAD and M_VIN to define nominal average output (LED) current of <math>0.1/R_{\text{M}}</math></li> </ul>
<b>VIN</b>	<b>12</b>	Positive supply to device (1.2-12V) <ul style="list-style-type: none"> <li>• Decouple to ground with capacitor close to device</li> </ul>
<b>TADJ</b>	<b>13</b>	Temperature adjust input for LED thermal compensation <ul style="list-style-type: none"> <li>• Connect thermistor/resistor network to this pin to reduce output current above a preset temperature threshold.</li> <li>• Connect to VREF to disable thermal compensation function (see section on temperature control for details)</li> </ul>
<b>VREF</b>	<b>14</b>	Internal 0.5V reference voltage output
<b>Exposed pad</b>	<b>15</b>	Connect to ground (0V)

## Electrical characteristics (Test conditions: $V_{IN} = 3V$ , $T_{AMB} = 25^{\circ}C$ unless otherwise stated<sup>(a)</sup>)

### DC-DC converter supply parameters

Symbol	Parameter	Conditions	Min	Typ	Max	Units
$V_{IN}$	Supply voltage	Normal operation	2.0		12	V
$V_{IN(Start)}$	Supply voltage for start-up <sup>(b)</sup>	Start-up mode	1.2		2.4	V
$V_{UV-}$	Under-voltage detection threshold Normal operation to start-up mode	$V_{IN}$ falling		1.8		V
$V_{UV+}$	Under-voltage detection threshold Start-up mode to normal operation	$V_{IN}$ rising		2.2		V
$I_q$	Quiescent current	Measured into $V_{IN}$ ADJ pin floating. (Excluding switch base current).		1.5		mA
$I_{STBY}$	Standby current	Measured into $V_{IN}$ . ADJ pin grounded		12	20	$\mu A$
$V_{REF}$	Internal reference voltage	ADJ pin floating $2.0V < V_{IN} < 18V$	480	500	520	mV
$TCO_{(REF)}$	Internal reference temperature coefficient.			50		ppm /K

#### NOTES:

(a) Production testing of the device is performed at 25°C. Functional operation of the device and parameters specified from -40°C to +125°C are guaranteed by design, characterisation and process control.

(b) Between 1.2V and 2.2V the device will run in the Low Voltage Startup Mode (for details refer to section "Low Voltage Operation")

### DC-DC converter input parameters

Symbol	Parameter	Conditions	Min	Typ	Max	Units
$V_{SENSE}$	Peak switch current sense voltage	Measured on ISENSE pin CFB pin at 0V	45	55	65	mV
$V_{SENSE(SU)}$	Peak switch current sense voltage in start-up mode	Measured on ISENSE pin. Start-up mode $V_{IN} = 1.2V$		10.5		mV
$I_{SENSE}$	Sense input current	Measured into ISENSE with pin at 0V. CFB pin at 0V	-15	-7	-1	$\mu A$
$C_{FB}$	Control loop compensation capacitor			10		nF
$V_{ADJ}$	External dc control voltage applied to ADJ pin to adjust output current	DC brightness control mode	50		500	mV
$V_{ADJ(th)}$	Switching threshold of ADJ pin	Standby state to normal operation	26	28	30	mV
$TCO_{(VADJ)}$	Temperature coefficient of $V_{ADJ(th)}$			+0.3		%/K
$R_{ADJ}$	Internal resistor between $V_{REF}$ and ADJ	$V_{ADJ} < 500mV$		100		k $\Omega$
$V_{ADJ(clmp)}$	Clamp voltage on ADJ pin	100 $\mu A$ injected into ADJ pin		575		mV

# ZXLD1321

## DC-DC converter output parameters

Symbol	Parameter	Conditions	Min	Typ	Max	Units
Toff(100)	Discharge pulse width	100% output current	0.7	1.2	1.7	µs
Toff(10)	Discharge pulse width	10% output current	4	8	12	µs
f <sub>LXmax</sub>	Maximum operating frequency				600	KHz
f <sub>SU</sub>	Switching frequency in start-up mode	V <sub>IN</sub> =1.2V		50		KHz

## Switching NPN transistor

Symbol	Parameter	Conditions	Min	Typ	Max	Units
I <sub>SW</sub>	Average continuous switch current <sup>(c)</sup>				2	A
I <sub>BON(max)</sub>	Maximum base current into switch transistor from internal drive circuit <sup>(d)</sup>	2V<V <sub>IN</sub> <18V BIAS pin at 0V	30	50	70	mA
I <sub>BON</sub>	Base current into switch transistor using external resistor (R <sub>BASE</sub> ) from BIAS pin to ground	R <sub>BIAS</sub> = 1680Ω		10		mA
V <sub>(BR)CEO</sub>	Collector-Emitter breakdown voltage	I <sub>C</sub> =10µA	20			V
V <sub>CE(sat)</sub>	Collector-Emitter saturation voltage	I <sub>C</sub> =0.1A, I <sub>B</sub> =10mA I <sub>C</sub> =2A, I <sub>B</sub> =50mA <sup>(e)</sup>		50 120		mV mV
h <sub>FE</sub>	Static forward current transfer ratio	I <sub>C</sub> =200mA, V <sub>CE</sub> =2V I <sub>C</sub> =2A, V <sub>CE</sub> =2V		209 116		
C <sub>OBO</sub>	Output capacitance	V <sub>CB</sub> =10V, f=1MHz		64		pF
t(on)	Turn-on time	I <sub>C</sub> =0 to I <sub>C</sub> =2A V <sub>IN</sub> =10V		30		ns
t(off)	Turn-off time	I <sub>C</sub> =2A to I <sub>C</sub> <100µA		28		ns

### NOTES:

(c) Measured under pulse conditions.

(d) This current is measured via the collectors and emitters of the switch with these connected to ground (0V)

(e) Measured under pulse conditions. Peak Current = I<sub>C</sub>

# ZXLD1321

## High-side current monitor

Symbol	Parameter	Conditions	Min	Typ	Max	Units
$V_{M\_VIN}$	Supply voltage		3		18	V
$V_{MON}$	Sense voltage	$=V(M\_VIN) - V(M\_LOAD)$	0	100	200	mV
$I_{M\_LOAD}$	Input current	Measured into M_LOAD pin		0.08	1	$\mu$ A
TCO (MON)	Temperature coefficient	$V_{MON}=10\text{mV}$ $V_{MON}=100\text{mV}$		370 150		ppm/ K
BW	Bandwidth	$V_{MON}=10\text{mV}$ $V_{MON}=100\text{mV}$		350 2.5		KHz MHz
Gm	Transconductance $\Delta I_{out}/\Delta V_{MON}$			1		$\text{mA/V}$
Acc	Accuracy	$RM = 0.1\Omega$ $V_{MON} = 100\text{mV}$	-3		3	%

## Reference current monitor

Symbol	Parameter	Conditions	Min	Typ	Max	Units
VADJ	Adjust Voltage		0		500	mV
TCO (MON)	Temperature Coefficient	$V_{ADJ}=50\text{mV}$ $V_{ADJ}=500\text{mV}$		160 200		ppm/ K
BW	Bandwidth	$V_{ADJ}=50\text{mV}$ $V_{ADJ}=500\text{mV}$		275 3		KHz MHz
Gm	Transconductance $\Delta I_{out}/\Delta V_{ADJ}$			200		$\mu\text{A/V}$
Acc	Accuracy	$V_{ADJ}=500\text{mV}$	-3		3	%

## LED thermal control circuit (TADJ) parameters

Symbol	Parameter	Conditions	Min	Typ	Max	Units
$V_{TADJH}$	Upper threshold voltage	Onset of output current reduction ( $V_{TADJ}$ falling)		75		mV
$V_{TADJL}$	Lower threshold voltage	Output current reduced to <10% of set value ( $V_{TADJ}$ falling)		50		mV
$G_{m(TADJ)}$	Transconductance $\Delta I_{out}/\Delta V_{TADJ}$			4		$\text{mA/V}$

# ZXLD1321

## Output current regulation parameters

Symbol	Parameter	Conditions	Min	Typ	Max	Units
$I_{OUT}$	Minimum output/ LED current <sup>(f)</sup>	$V_{IN} > 3V$		2		A
$\Delta I_{OUT}$	Output current accuracy <sup>(g)</sup>	$3.0V < V_{IN} < 12V$ , $I_{out} = 1A$ , $V_{ADJ} = 100mV$	-5		+5	%
$TCO$ $I_{(OUT)}$	Output current temperature drift	$3.0V < V_{IN} < 12V$ , $I_{out} = 1A$ , $V_{ADJ} = 100mV$		100	200	ppm/ K
$\Delta I_{OUT}/$ $I_{OUT}$	Load current regulation	$350mA < I_{(LED)} < 1A$		2		%/A
$\Delta I_{OUT}/$ $\Delta V_{IN}$	Line voltage regulation of output current			0.5		%/V
Eff	Efficiency <sup>(f)</sup>	$350mA < I_{(LED)} < 1A$		85		%

### NOTES:

(f) System parameter only. This value is dependent upon external components and circuit configuration.

(g) This refers to the accuracy of output current regulation under normal operation when the feedback loop incorporating the current monitor is active. The tolerances of external components are not included in this figure.

## Ordering information

Device	Reel size (mm)	Reel width (mm)	Quantity per reel	Device mark
ZXLD1321DCATC	33.02	12	3,000	1321



## Device description

The ZXLD1321 is a inductive boost DC-DC converter, with an internal switch, designed for driving single or multiple LEDs in series up to a total of 1A output current. Depending upon supply voltage ( $V_{IN}$ ), LED forward voltage drop ( $V_{LED}$ ) and circuit configuration, this can provide up to 8W of output power.

Applications cover  $V_{IN}$  ranging from 1.2V to 12V.

The device employs a modified Pulse Frequency Modulation (PFM) control scheme, with variable "ON" and "OFF" time control and adjustable peak switch current limiting.

## General device operation (refer to block diagram)

### Normal operation

Control is achieved by sensing the LED current in a series resistor ( $R_M$ ), connected between the two inputs of the LED Current Monitor. This generates a proportional current ( $I_{MON}$ ) that charges the external integrator capacitor  $C_{FB}$ .  $I_{MON}$  is balanced against a reference discharge current ( $I_{ADJ}$ ) generated at the output of a second voltage to current converter driven from the demand voltage ( $V_{ADJ}$ ) on the ADJ pin. The difference between  $I_{MON}$  and  $I_{ADJ}$  is integrated by  $C_{FB}$  to produce an error voltage. A comparator takes a summed version of the voltage at the ISENSE pin and a fraction of this CFB voltage and resets the latch driving the switch when the sum is greater than 50mV. The switch transistor is turned on by the output of the SR latch, which remains set until the emitter current in the switch transistor produces a voltage drop  $V_{sense}$  (=50mV nominal) in external resistor  $R_{sense}$ , defining a preset maximum switch current of  $50mV/R_{sense}$ . Operation is such that a rising error voltage on CFB will effectively lower the voltage required on the ISENSE pin and therefore reset the latch earlier in the switching cycle. This will reduce the 'ON' time of the switch and reduce the peak current in the switch from its preset maximum value. Similarly, a falling error voltage will reset the latch later and the peak switch current will be increased. The control loop therefore reduces or increases the energy stored in the coil during each switching cycle, as necessary, to force the LED current to the set value. This results in high accuracy, as no error is needed in the LED current to drive the servo to the required region.

The time taken for the coil current to reach the peak value depends on several factors: the supply voltage, the peak coil current required at that particular LED power and whether the system operates in "continuous" or "discontinuous" mode. The time allowed for the coil current to discharge into the LED is fixed by the 'Variable Off Delay' monostable, whose period is modified by the power demand signal on the ADJ pin. This monostable determines the time for which the latch remains reset (switch off) and provides a longer "OFF" period at lower power settings, helping to keep the parameters within an acceptable range.

Note that the "ON" period and the "OFF" period are set by the supply voltage, LED power and external components chosen. The frequency is therefore determined by these parameters and is NOT fixed. In this modified PFM scheme, the external components can be chosen to keep the frequency well above the audio range for all extremes of parameters, so no audible whistling should ever occur.

The 500mV reference voltage defines the nominal  $V_{ADJ}$  voltage and this defines the 100% output current. For lower LED currents, the ADJ pin can be driven from an external dc voltage ( $50mV < V_{ADJ} < 500mV$ ) or a low frequency Pulse Width Modulated (PWM) waveform.

## Low voltage operation (start-up mode)

For supply voltages below 2V, the normal control loop will have insufficient headroom to operate reliably. This condition is detected by the 'under-voltage comparator', which compares a fraction of the internal supply voltage ( $V_{cc}$ ) against  $V_{REF}$ . When the comparator output is active ( $V_{cc} < 1.8V$ ), the output of the normal switch drive circuit is disabled and an alternative 'Start-up oscillator and driver' enabled. The start-up oscillator provides a nominal 50kHz fixed frequency drive signal to the base of the switch transistor, which is independent of  $V_{ADJ}$  and the voltage on  $CFB$ . Under low voltage conditions, the peak current in the coil ramps to approximately 25% of the normal value and the "OFF" time is fixed.

The low voltage start-up mode allows the device to operate down to 1.2V nominal. This allows the chip to work from a single cell in boost mode and by configuring the device in Bootstrap mode, normal operation of the control loop will occur once the output has risen above 2.2V. Details of Bootstrap-Boost mode are given in the application notes.

## ADJ pin

The ADJ pin is connected to the internal 500mV reference ( $V_{REF}$ ) via a 100k resistor. This biases the ADJ pin to the reference voltage and defines nominal 100% LED current.

The ADJ pin can be overdriven with an external dc voltage between 50mV and 500mV to reduce the LED current proportionally between 10% and 100% of the nominal value.

LED current can also be adjusted by applying a low frequency PWM signal to the ADJ pin to turn the device On and Off. This will produce an average output current proportional to the duty cycle of the control signal.

The device can be shut down by shorting the ADJ pin to ground, or pulling it to a voltage below 28mV with a suitable open collector NPN or open drain NMOS transistor. In the shutdown state, most of the circuitry inside the device is switched off and residual quiescent current will be typically 12 $\mu$ A.

## Thermal control of LED current

The 'Thermal compensation current' circuit produces a sourcing current ( $I_{tc}$ ) which is zero for voltages above 75mV on  $T_{ADJ}$  and increases to 100 $\mu$ A when  $T_{ADJ}$  falls to 50mV. This current is summed into the control node and subtracted from the demand current, causing LED current to reduce from 100% down to zero over this input range. The potential divider, consisting of a fixed resistor  $R_t$  and an NTC Thermistor  $R_{th}$  between  $V_{REF}$  and ground, defines the voltage on  $T_{ADJ}$  and sets the threshold temperature. Further details are given in the application notes.

The Thermal Control feature can be disabled by leaving the  $T_{ADJ}$  pin floating, or by connecting it to  $V_{REF}$ .

## Over-temperature shutdown

The ZXLD1321 incorporates an over-temperature shutdown circuit to protect the device against damage caused by excess die temperature, resulting from excessive power dissipation in the switch. The output of the 'Over-temp Shutdown' circuit will go high when the die temperature exceeds 150°C (nominal). This will turn off the drive to the switch during normal operation. Operation will resume when the device has cooled to a safe level.

## Application notes

### Setting peak coil current

The peak current in the coil is set by the resistor ( $R_{SENSE}$ ) between the switch emitter and ground according to

$$I_{SWpeak} = \frac{50mV}{R_{sense}}$$

The minimum peak current will depend on operating mode, coil inductance and supply voltage range. The maximum peak current must not exceed the specified value for the switch. (See Application circuits for details).

### Setting LED current

The nominal average LED current is given by

$$I_{LED(nom)} = \frac{100mV}{R_M}$$

Where  $R_M$  is the external resistor connected between pins M\_VIN and M\_LOAD.

This current can be adjusted to a lower value by applying a dc control voltage or PWM control signal to the ADJ pin.

### DC control

The LED current can be adjusted over a 10% to 100% range by connecting a variable resistor  $R_{ADJ}$  from the ADJ pin to ground to vary the dc voltage at the ADJ pin.  $R_{ADJ}$  forms the lower part of a resistive divider and the internal 100k $\Omega$  resistor between the ADJ and VREF pins forms the upper part. A value of 1M $\Omega$  for  $R_{ADJ}$  will therefore give a maximum current of 91% of  $I_{LED(nom)}$  and the device will be turned off when the voltage on the ADJ pin falls below 28mV, corresponding to an  $R_{ADJ}$  value of approximately 5k $\Omega$ . If required, an end-stop resistor in series with  $R_{ADJ}$  can be used to maintain the voltage on the ADJ pin above the turn-on threshold.

Using a logarithmic potentiometer for  $R_{ADJ}$  will give an approximately linear variation of output current with shaft rotation. (Fig 1)

If required, the maximum output current can be restored to 100% by adjusting the value of the LED current monitor resistor ( $R_M$ ). The tolerance of the internal 100k resistor and  $R_{ADJ}$  should be taken into account when calculating output current.

The ADJ pin is clamped internally to a voltage of 575mV (nom), to limit maximum average output current to approximately 115% of  $I_{LED(nom)}$ .

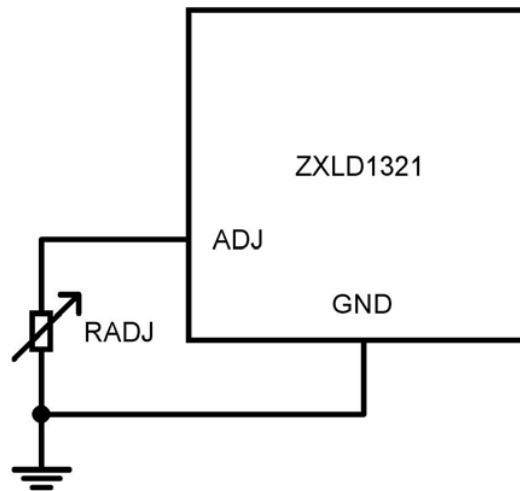

Fig 1

## PWM control

A wider dimming range can be achieved by applying a PWM control signal to the ADJ pin to turn the device on and off, giving an average output current proportional to the duty cycle of the control signal. The ADJ pin can be driven directly from the open drain NMOS output of a microcontroller, or indirectly with a low saturation voltage NPN transistor such as the Zetex ZXTN25015DFH. (Fig 2).

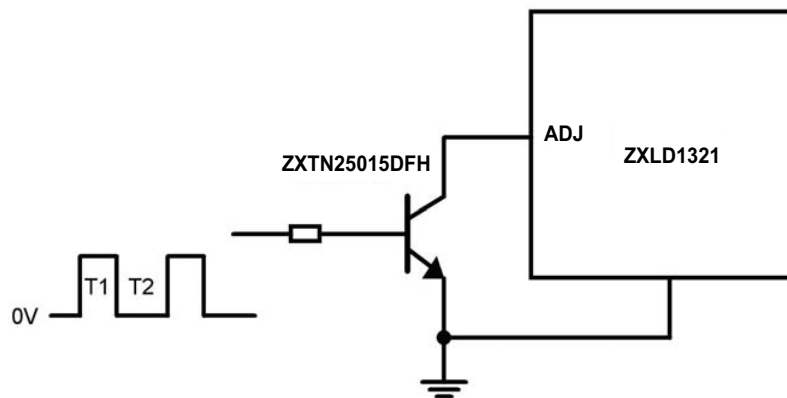

Fig 2

In the circuit of Fig 4, the average LED output current will be

$$I_{LED}(avg) = I_{LED}(nom) * D$$

Where duty cycle

$$D = \frac{T2}{(T1+T2)}$$

A PWM frequency of 200Hz, or lower is recommended, to minimize errors due to the rise and fall times of the converter output.

## Thermal compensation of LED current

High-luminance LEDs often need to be supplied with a temperature compensated current in order to maintain stable and reliable operation at high temperatures. This is usually achieved by reducing the LED current proportionally from its nominal set value when the LED temperature rises above a predefined threshold. (Fig.3)

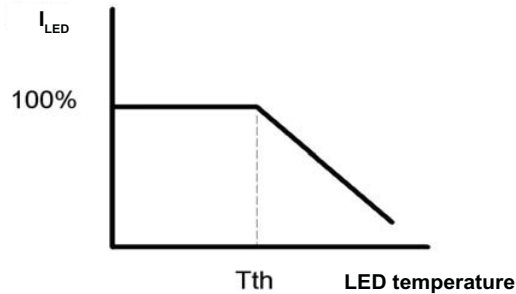

Fig 3

The 'Thermal compensation current' generator inside the ZXLD1321 provides the necessary thermal compensation current to meet this requirement, using an NTC thermistor and resistor. (Fig 4)

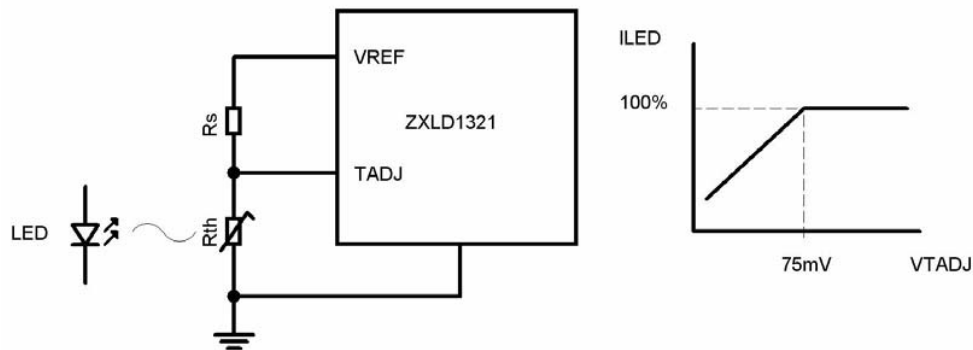

Fig 4

The  $T_{ADJ}$  pin of the device has a voltage threshold of 75mV nominal, which is derived from the reference voltage  $V_{REF}$ . If the voltage ( $V_{TADJ}$ ) on the  $T_{ADJ}$  pin is held above the threshold, the thermal compensation current will be zero and no thermal compensation is applied. However, if  $V_{TADJ}$  falls below the threshold, a thermal compensation current ( $I_{TC}$ ) is produced that is proportional to  $V_{TADJ}$ .  $I_{TC}$  is injected into the control loop in such a way as to reduce the demand current  $I_{ADJ}$ , causing the control loop to decrease the LED current. The LED current will be reduced to less than 10% of the set value when  $V_{TADJ}$  falls below 50mV.

The threshold voltage has been chosen to set a nominal threshold of 105°C and the device has been optimized to operate with a standard 103KT1608 thermistor and 5k resistor in the potential divider. Circuit details are given in the application notes. Alternative thermistor/resistor networks can be used providing the input resistance presented to the device at the  $T_{ADJ}$  pin is similar at the threshold temperature. If no LED thermal compensation is required, the  $T_{ADJ}$  pin should be connected to  $V_{REF}$  to disable this function.

## Typical operating conditions

Inductive converters can operate in either CONTINUOUS mode, where current always flows in the inductor, but rises during the ON period and falls during the OFF period, or DISCONTINUOUS mode, where the current falls to zero during the OFF period. The mode depends on several factors, including supply voltage, output (LED) voltage and the choice of peak current and inductor value. Calculations need to be done to determine which mode the converter will be in. The circuit should be designed to give slightly more LED current than required under the lowest supply voltage, so the control loop can regulate the current accurately. If the theoretical LED current is less than that required, the control loop will not be able to reach the required value. The calculations will give an idea of the ON and OFF times and hence the operating frequency, but bear in mind that the control loop will reduce the peak current to achieve the exact programmed LED current and this will raise the operating frequency. In general, values in the discontinuous mode are simpler to calculate because the current can go from zero to the theoretical maximum during the ON period and fall to zero during the OFF period. In continuous mode the current will start from some value, so the ON time will be lower to reach the theoretical maximum and lower still when the control loop reduces the peak current below the maximum.

### Circuit operation

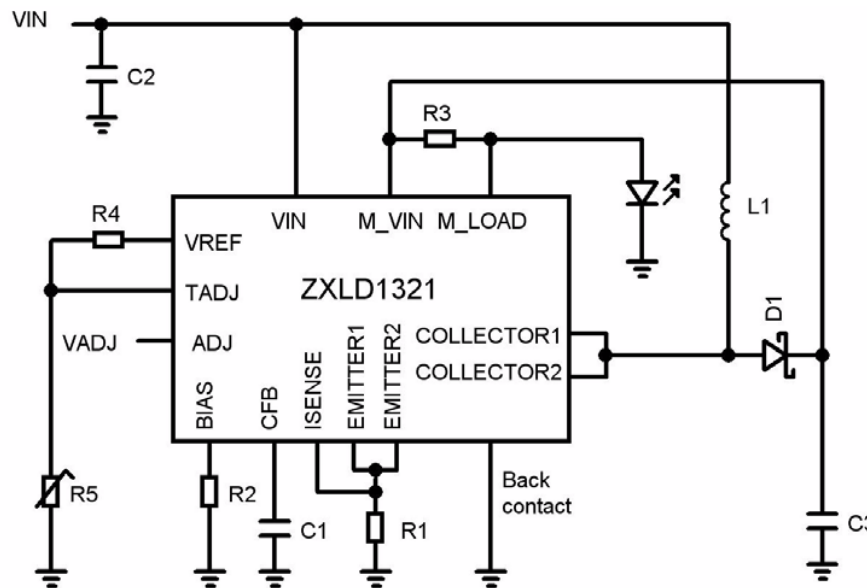

DIAGRAM A

### Operation of boost LED driver

The input voltage must always be lower than the LED voltage. This circuit has an ON phase, where the coil is connected from the supply to ground and an OFF phase, where the coil current flows through the LED via a Schottky diode. The current therefore only flows into the LED circuit during the OFF phase, although the reservoir capacitor C3 should keep current flowing in the LED(s) continuously.

ADJ is set between 50mV and 500mV to give between 10% and 100% power respectively. Making R2 = zero gives a base current to the output transistor of 50mA nominal and making R2 = 1.68kΩ gives 10mA nominal. The reduced base current will lower supply current and hence improve efficiency in lower power applications. Making R1 = 25mΩ gives a peak coil current of 2 Amps. The internal power transistor turns on until the coil current builds up to the peak value. At this point the transistor switches off and the coil current continues to flow in the LED(s) via Schottky diode D1.

# ZXLD1321

The LED current is sensed by R3 and the controller varies this until the drop in R3 equals 20% of  $V_{ADJ}$ . Hence making  $R3 = 100m\Omega$  and  $V_{ADJ} = 500mV$  gives a LED current of 1 Amp because the 500mV  $V_{ADJ}$  results in 100mV across R3 which equals 1 Amp. Making  $V_{ADJ} = 10mV$  gives a LED current of 100mA because the 50mV  $V_{ADJ}$  results in 10mV drop across R3 which equals 100mA.

The power is controlled by the chip backing off the peak coil current, so it is necessary to calculate the coil inductance and current to guarantee slightly more than 100% LED power, so the circuit can control it effectively. The internal control loop is compensated by C1, which is normally 10nF.

If the thermistor (R5) is used, the power will be backed off progressively as the TADJ pin goes low. With the TADJ pin above 75mV, power is 100% and this is reduced to zero when the TADJ pin reaches 50mV. Making  $R4 = 5k\Omega$  and using a 103KT1608 thermistor, the thermistor will reach  $869\Omega$  at 105°C giving  $V_{TADJ} = 74mV$  which will start to reduce the LED power above 105°C. By 125°C the thermistor will reach  $547\Omega$  giving  $V_{TADJ} = 50mV$  which gives zero power. This will protect the LED from damage. These temperature values can be set by the customer by using a different thermistor or a different value of R4. If protection is not required, leaving the TADJ pin open circuit will make it float to a high voltage and always give 100% power.

Reference	Part No	Value	Manufacturer	Contact Details
U1	ZXLD1321	LED Driver	Zetex	www.zetex.com
D1	ZXCS2000	Schottky diode	Zetex	
L1	MSS7341-103ML	10 $\mu$ H 2A	Coilcraft	www.coilcraft.com
L1	NPIS64D100MTRF	10 $\mu$ H 2A	NIC	www.niccomp
L1	744 77810	10 $\mu$ H 2A	Würth	www.wurth.co.uk
C1	Generic	10nF 10V	Generic	
C2	GRM31CR71H475K	4.7 $\mu$ F 50V	Murata 1206	www.murata.com
C3	GRM31MR71E225K	2.2 $\mu$ F 25V	Murata 1206	www.murata.com
R1	Generic	25m $\Omega$	Generic 0805	
R2	Generic		Generic 0603	
R3	Generic	100m $\Omega$	Generic 0805	
R4	Generic	5.1k $\Omega$	Generic 0603	
R5	Thermistor NTC	10k	103kt1608	

## Operation in bootstrap mode

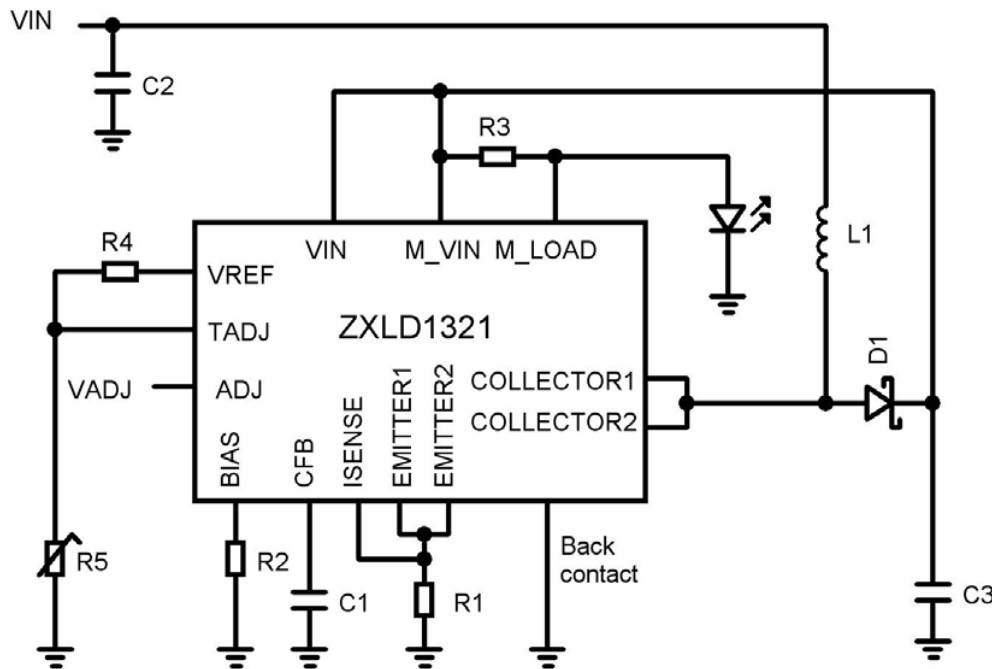

Diagram B : Bootstrap mode

## Operation of bootstrap LED driver

This is used when the input voltage is less than 2 volts. Note that the chip VIN now goes to the cathode of the Schottky diode D1. The control loop can not operate at this low voltage, so the chip goes into a start-up mode, where the output transistor is switched on and off at nominally 50kHz with a 50:50 duty cycle with about 10mA of base current into the power transistor (20% of nominal). The emitter current is still sensed by R1 and the "ON" part of the duty cycle will be terminated either when the emitter sense voltage reaches 10mV (corresponding to 20% of the set peak current) or the ON part of the duty cycle finishes after 10µs. There is no control of the LED current yet, the circuit just operates in Boost mode. Eventually, the reservoir capacitor C3 charges up to 2V and the chip goes into "Normal" mode, where it delivers 50mA to the base of the power transistor and the control loop works normally. It will continue to charge C3 until the LED current is correctly established, with the chip now running from a voltage equal to the LED forward drop (around 3.6V for one LED) even though the supply is still below 2 volts. Once the circuit has reached this condition, the rest of the description of the operation is the same as for the Boost operation.

Like the Boost circuit, this circuit has an ON phase, where the coil is connected from the supply to ground and an OFF phase, where the coil current flows through the LED via the Schottky diode D1. The current therefore only flows into the LED circuit during the OFF phase, although the reservoir capacitor C2 should keep current flowing in the LED(s) continuously.

ADJ is set between 50mV and 500mV to give between 10% and 100% power respectively. Making R2 = zero gives a base current to the output transistor of 50mA nominal and making R2 = 1.68kΩ gives 10mA nominal. The reduced base current will lower supply current and hence improve efficiency in lower power applications. Making R1 = 50mΩ gives a peak coil current of 1 Amps. The internal power transistor turns on until the coil current builds up to the peak. At this point the transistor switches off and the coil current continues to flow in the LED(s) via Schottky diode D1.



# ZXLD1321

The LED current is sensed by R3 and the controller varies this until the drop in R3 equals 20% of VADJ. Hence making R3 = 100m $\Omega$  and VADJ = 500mV gives a LED current of 1 Amp because the 500mV VADJ results in 100mV across R3 which equals 1 Amp. Making VADJ = 10mV gives a LED current of 100mA because the 50mV VADJ results in 10mV drop across R3 which equals 100mA.

The power is controlled by the chip backing off the peak coil current, so it is necessary to calculate the coil inductance and current to guarantee slightly more than 100% LED power, so the circuit can control it effectively. The internal control loop is compensated by C1, which is normally 10nF. Note that in Bootstrap mode, the input current will be 2 or 3 times larger than the LED current and the duty cycle will be such that TON is larger than TOFF, due to the fact that the supply voltage charging the coil is low. Because of this, large LED currents can not be programmed at very low supply voltages, as the transistor current would need to exceed 2 Amps.

If the thermistor (R5) is used, the power will be backed off progressively as the TADJ pin goes low. With the TADJ pin above 75mV, power is 100% and this is reduced to zero when the TADJ pin reaches 50mV. Making R4 = 5k $\Omega$  and using a 103KT1608 thermistor, the thermistor will reach 869 $\Omega$  at 105 $^{\circ}$ C giving TADJ = 74mV which will start to reduce the LED power above 105 $^{\circ}$ C. By 125 $^{\circ}$ C the thermistor will reach 547 $\Omega$  giving TADJ = 50mV which gives zero power. This will protect the LED from damage. These temperature values can be set by the customer by using a different thermistor or a different value of R4. If protection is not required, leaving the TADJ pin open circuit will make it float to a high voltage and always give 100% power.

Reference	Part No	Value	Manufacturer	Contact Details
U1	ZXLD1321	LED Driver	Zetex	www.zetex.com
D1	ZXCS2000	Schottky diode	Zetex	
L1	MSS7341-103ML	10 $\mu$ H 2A	Coilcraft	www.coilcraft.com
L1	NPIS64D100MTRF	10 $\mu$ H 2A	NIC	www.niccomp
L1	744 777910	10 $\mu$ H 2A	Würth	www.wurth.co.uk
C1	Generic	10nF 10V	Generic	
C2	GRM31CR71H475K	4.7 $\mu$ F 50V	Murata 1206	www.murata.com
C3	GRM31MR71E225K	2.2 $\mu$ F 25V	Murata 1206	www.murata.com
R1	Generic	25m $\Omega$	Generic 0805	
R2	Generic		Generic 0603	
R3	Generic	100m $\Omega$	Generic 0805	
R4	Generic	5.1k $\Omega$	Generic 0603	
R5	Thermistor NTC	10k	103kt1608	

## Additional notes which apply to all operational modes

Note with all these circuits that the ON time is set by the time it takes the coil to reach the peak current. This peak value is reduced by the control loop to give the desired LED power, so the ON time can vary over a wide range. The minimum coil current can be zero (discontinuous operation) or finite (continuous operation) depending on the supply voltage, LED current and the LED voltage. The OFF time is set by an internal timer and is nominally  $1.2\mu\text{s}$  at 100% LED power ( $V_{\text{ADJ}} = 500\text{mV}$ ), increasing to about  $8\mu\text{s}$  at 10% LED power ( $V_{\text{ADJ}} = 50\text{mV}$ ). The longer OFF time and variable peak current enables the circuit to dim the LED whilst maintaining continuous switching, rather than "skipping" or stalling and continuous running is better for reducing electrical noise and also for eliminating audible noise from the coil core.

## Layout considerations

As with all switching DC to DC converters, the currents can be large. Using small inductors with a reasonably high supply voltage will cause currents to change quickly. High  $dI/dt$  can cause inductively-coupled spikes into adjacent tracks. At the transition from of the ON phase to the OFF phase and back, where the power transistor switches, the voltage at the collector rises and falls quickly. High  $dV/dt$  can cause capacitively coupled spikes into adjacent tracks, especially if they have a high impedance. For this reason, all tracks on the PCB should be thick, to minimise drops, and short to keep all the components coupled tightly together.

A double-sided board should be used with a ground plane to screen the tracks and provide a good ground return for the various functions and the rear exposed pad on the package should have an appropriately-sized land with good ground connections, both to reduce electrical noise due to ground drops and to improve thermal conductivity.

The input decoupling capacitor C1 should be very close to the chip pins and the LED sense resistor R3 should have Kelvin tracks to M\_VIN and M\_LOAD to achieve LED current measurement accuracy, as the PCB tracks will have comparable resistance to the  $100\text{m}\Omega$  resistor, so taking sense tracks to the current monitor which are not connected close to the ends of R3 will cause a measurement error.

The peak current sense resistor R1 should have short tracks to the ground at the bottom end and Kelvin tracks to ISENSE at the top end. This resistor might need to be only  $25\text{m}\Omega$  and PCB track resistance becomes comparable if the tracks are not very short. ISENSE is a high impedance input, so a thin track from this pin directly to the top of R\_SENSE resistor R1 will still give an accurate measurement.

The ADJ pin should have short tracks, as this is a fairly low-level signal controlling the power of the system. As it needs to be less than  $28\text{mV}$  for shutdown, a close ground connection is needed for the pull-down device, as any ground drops could raise the potential. In particular, if a bipolar transistor is used as a pull-down device, this will have an appreciable  $V_{\text{SAT}}$ , which could perhaps be half the shutdown potential.

The bottom of the thermistor must be coupled very closely to ground, as the TADJ pin varies the LED current from 100% to 0% for a voltage change of only  $25\text{mV}$ , so any noise on the bottom of the thermistor will seriously affect the accuracy of the Thermal Protection circuit.

# ZXLD1321

## Package outline - TDFN1443

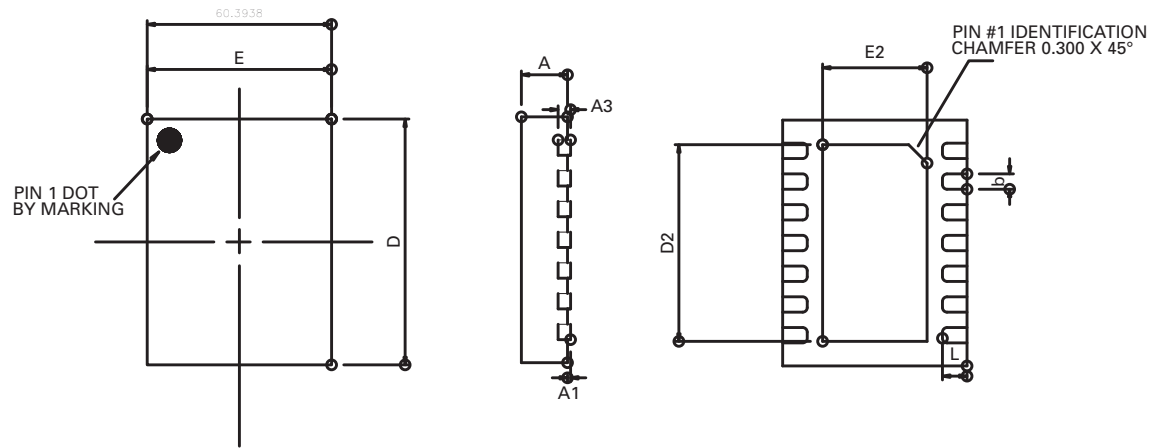

DIM	Inches		Millimeters		DIM	Inches		Millimeters	
	Min	Max	Min	Max		Min	Max	Min	Max
A	0.0276	0.0315	0.70	0.80	D2	0.1240	0.1279	3.15	3.25
A1	0.00	0.002	0.00	0.05	e	0.0197 BSC		0.50 BSC	
A3	0.008 REF.		0.203 REF.		E	0.1161	0.1201	2.95	3.05
b	0.0079	0.0118	0.20	0.30	E2	0.0650	0.0689	1.65	1.75
D	0.1555	0.1594	3.95	4.05	L	0.0138	0.0177	0.35	0.45

**Note:** Controlling dimensions are in millimeters. Approximate dimensions are provided in inches

## Definitions

### Product change

Zetex Semiconductors reserves the right to alter, without notice, specifications, design, price or conditions of supply of any product or service. Customers are solely responsible for obtaining the latest relevant information before placing orders.

### Applications disclaimer

The circuits in this design/application note are offered as design ideas. It is the responsibility of the user to ensure that the circuit is fit for the user's application and meets with the user's requirements. No representation or warranty is given and no liability whatsoever is assumed by Zetex with respect to the accuracy or use of such information, or infringement of patents or other intellectual property rights arising from such use or otherwise. Zetex does not assume any legal responsibility or will not be held legally liable (whether in contract, tort (including negligence), breach of statutory duty, restriction or otherwise) for any damages, loss of profit, business, contract, opportunity or consequential loss in the use of these circuit applications, under any circumstances.

### Life support

Zetex products are specifically not authorized for use as critical components in life support devices or systems without the express written approval of the Chief Executive Officer of Zetex Semiconductors plc. As used herein:

A. Life support devices or systems are devices or systems which:

1. are intended to implant into the body

or

2. support or sustain life and whose failure to perform when properly used in accordance with instructions for use provided in the labelling can be reasonably expected to result in significant injury to the user.

B. A critical component is any component in a life support device or system whose failure to perform can be reasonably expected to cause the failure of the life support device or to affect its safety or effectiveness.

### Reproduction

The product specifications contained in this publication are issued to provide outline information only which (unless agreed by the company in writing) may not be used, applied or reproduced for any purpose or form part of any order or contract or be regarded as a representation relating to the products or services concerned.

### Terms and Conditions

All products are sold subjects to Zetex' terms and conditions of sale, and this disclaimer (save in the event of a conflict between the two when the terms of the contract shall prevail) according to region, supplied at the time of order acknowledgement.

For the latest information on technology, delivery terms and conditions and prices, please contact your nearest Zetex sales office.

### Quality of product

Zetex is an ISO 9001 and TS16949 certified semiconductor manufacturer.

To ensure quality of service and products we strongly advise the purchase of parts directly from Zetex Semiconductors or one of our regionally authorized distributors. For a complete listing of authorized distributors please visit: [www.zetex.com/salesnetwork](http://www.zetex.com/salesnetwork)

Zetex Semiconductors does not warrant or accept any liability whatsoever in respect of any parts purchased through unauthorized sales channels.

### ESD (Electrostatic discharge)

Semiconductor devices are susceptible to damage by ESD. Suitable precautions should be taken when handling and transporting devices. The possible damage to devices depends on the circumstances of the handling and transporting, and the nature of the device. The extent of damage can vary from immediate functional or parametric malfunction to degradation of function or performance in use over time. Devices suspected of being affected should be replaced.

### Green compliance

Zetex Semiconductors is committed to environmental excellence in all aspects of its operations which includes meeting or exceeding regulatory requirements with respect to the use of hazardous substances. Numerous successful programs have been implemented to reduce the use of hazardous substances and/or emissions.

All Zetex components are compliant with the RoHS directive, and through this it is supporting its customers in their compliance with WEEE and ELV directives.

### Product status key:

"Preview"	Future device intended for production at some point. Samples may be available
"Active"	Product status recommended for new designs
"Last time buy (LTB)"	Device will be discontinued and last time buy period and delivery is in effect
"Not recommended for new designs"	Device is still in production to support existing designs and production
"Obsolete"	Production has been discontinued

### Datasheet status key:

"Draft version"	This term denotes a very early datasheet version and contains highly provisional information, which may change in any manner without notice.
"Provisional version"	This term denotes a pre-release datasheet. It provides a clear indication of anticipated performance. However, changes to the test conditions and specifications may occur, at any time and without notice.
"Issue"	This term denotes an issued datasheet containing finalized specifications. However, changes to specifications may occur, at any time and without notice.

### Zetex sales offices

Europe	Americas	Asia Pacific	Corporate Headquarters
Zetex GmbH Kustermann-park Balanstraße 59 D-81541 München Germany Telefon: (49) 89 45 49 49 0 Fax: (49) 89 45 49 49 49 europe.sales@zetex.com	Zetex Inc 700 Veterans Memorial Highway Hauppauge, NY 11788 USA Telephone: (1) 631 360 2222 Fax: (1) 631 360 8222 usa.sales@zetex.com	Zetex (Asia Ltd) 3701-04 Metroplaza Tower 1 Hing Fong Road, Kwai Fong Hong Kong Telephone: (852) 26100 611 Fax: (852) 24250 494 asia.sales@zetex.com	Zetex Semiconductors plc Zetex Technology Park, Chadderton Oldham, OL9 9LL United Kingdom Telephone: (44) 161 622 4444 Fax: (44) 161 622 4446 hq@zetex.com

© 2008 Published by Zetex Semiconductors plc