

# TZA3026

## SDH/SONET STM4/OC12 transimpedance amplifier

Rev. 01 — 2 May 2005

Product data sheet

### 1. General description

The TZA3026 is a transimpedance amplifier with Automatic Gain Control (AGC), designed to be used in STM4/OC12 fiber optic links. It amplifies the current generated by a photo detector (PIN diode or avalanche photodiode) and converts it to a differential output voltage. It offers a current mirror of average photo current for RSSI monitoring to be used in SFF8472 compliant modules.

The low noise characteristics makes it suitable for STM4/OC12 applications, but also for FTTx applications.

### 2. Features

- Low equivalent input noise current, typically 67 nA (RMS)
- Wide dynamic range, typically 0.85  $\mu$ A to 1.5 mA (p-p)
- Differential transimpedance of 14 k $\Omega$  (typical)
- Bandwidth from DC to 650 MHz (typical)
- Differential outputs
- On-chip AGC with possibility of external control
- Single supply voltage 3.3 V, range 2.9 V to 3.6 V
- Bias voltage for PIN diode
- Current output of average photo current for RSSI monitoring
- Identical ports available on both sides of die for easy bond layout and RF polarity selection

### 3. Applications

- Digital fiber optic receiver modules in telecommunications transmission systems, in high speed data networks or in FTTx systems

### 4. Ordering information

Table 1: Ordering information

Type number	Package		
	Name	Description	Version
TZA3026U	-	bare die, dimensions approximately 0.82 mm $\times$ 1.3 mm	-

**PHILIPS**

**5. Block diagram**

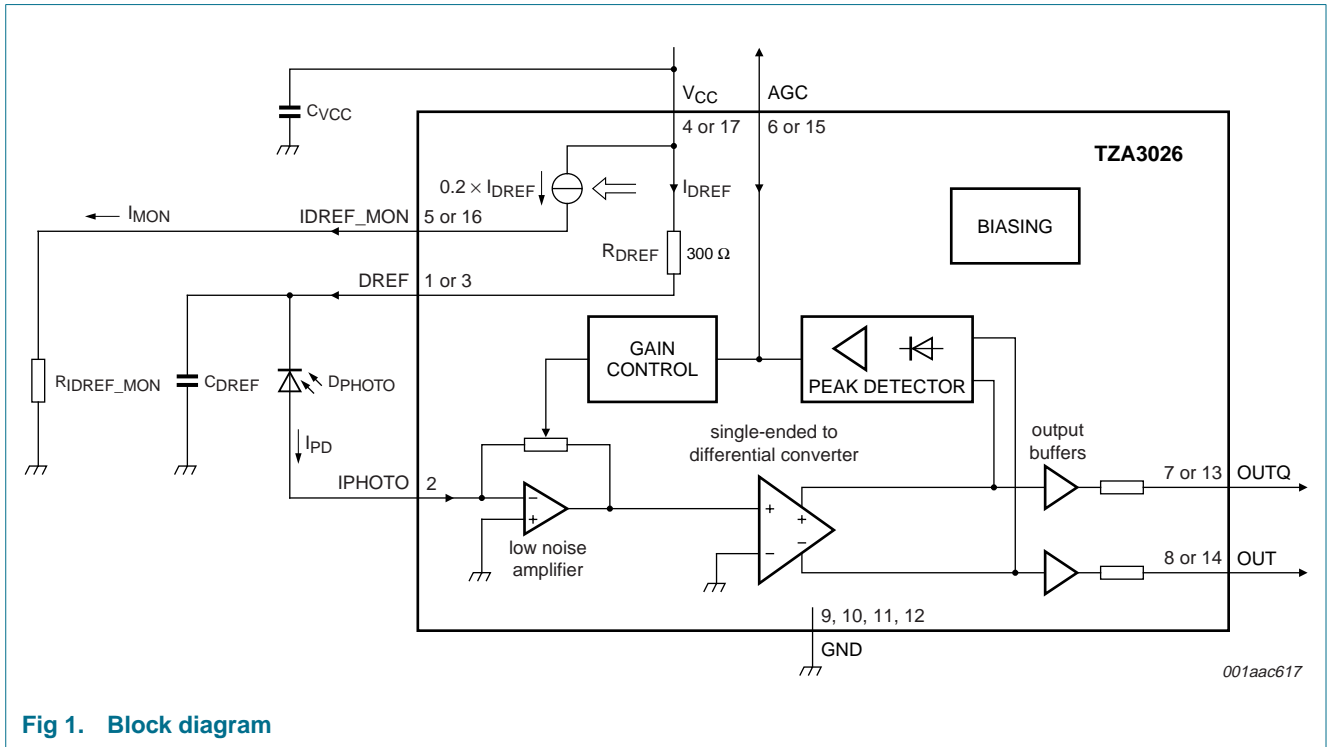

**Fig 1. Block diagram**

## 6. Pinning information

### 6.1 Pinning

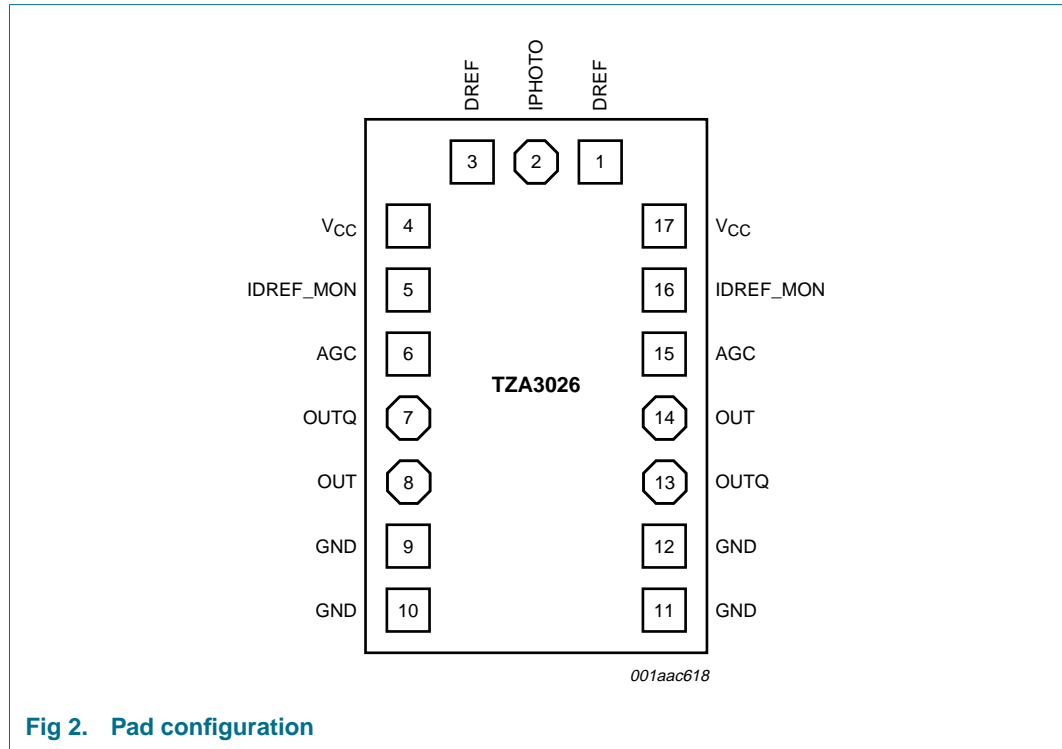

Fig 2. Pad configuration

### 6.2 Pin description

**Table 2: Bonding pad description**

Bonding pad locations with respect to the center of the die (see [Figure 10](#)), X and Y are in  $\mu\text{m}$ .

Symbol	Pad	X	Y	Type	Description
DREF	1	-493.6	140	output	bias voltage output for PIN diode; connect cathode of PIN diode to pad 1 or pad 3
IPHOTO	2	-493.6	0	input	current input; anode of PIN diode should be connected to this pad
DREF	3	-493.6	-140	output	bias voltage output for PIN diode; connect cathode of PIN diode to pad 1 or pad 3
V <sub>CC</sub>	4	-353.6	-278.6	supply	supply voltage; connect supply voltage to pad 4 or pad 17
IDREF_MON	5	-213.6	-278.6	output	current output for RSSI measurements; connect a resistor to pad 5 or pad 16 and ground
AGC	6	-73.6	-278.6	input	AGC voltage; use pad 6 or pad 15
OUTQ	7	66.4	-278.6	output	data output; complement of pad OUT; use pad 7 or pad 13
OUT	8	206.4	-278.6	output	data output; use pad 8 or pad 14 <a href="#">[1]</a>
GND	9	346.4	-278.6	ground	ground; connect together pads 9, 10, 11 and pad 12 as many as possible
GND	10	486.4	-278.6	ground	ground; connect together pads 9, 10, 11 and pad 12 as many as possible

**Table 2: Bonding pad description ...continued**

Bonding pad locations with respect to the center of the die (see [Figure 10](#)), X and Y are in  $\mu\text{m}$ .

Symbol	Pad	X	Y	Type	Description
GND	11	486.4	278.6	ground	ground; connect together pads 9, 10, 11 and pad 12 as many as possible
GND	12	346.4	278.6	ground	ground; connect together pads 9, 10, 11 and pad 12 as many as possible
OUTQ	13	206.4	278.6	output	data output; complement of pad OUT; use pad 7 or pad 13
OUT	14	66.4	278.6	output	data output; use pad 8 or pad 14 <a href="#">[1]</a>
AGC	15	-73.6	278.6	input	AGC voltage; use pad 6 or pad 15
IDREF_MON	16	-213.6	278.6	output	current output for RSSI measurements; connect a resistor to pad 5 or pad 16 and ground
V <sub>CC</sub>	17	-353.6	278.6	supply	supply voltage; connect supply voltage to pad 4 or pad 17

[1] These pads go HIGH when current flows into pad IPHOTO.

## 7. Functional description

The TZA3026 is a TransImpedance Amplifier (TIA) intended for use in fiber optic receivers for signal recovery in STM4/OC12 or FTTx applications. It amplifies the current generated by a photo detector (PIN diode or avalanche photodiode) and converts it to a differential output voltage.

The most important characteristics of the TZA3026 are high receiver sensitivity, wide dynamic range and large bandwidth. Excellent receiver sensitivity is achieved by minimizing transimpedance amplifier noise.

The TZA3026 has a wide dynamic range to handle the signal current generated by the PIN diode which can vary from 0.85  $\mu\text{A}$  to 1.5 mA (p-p). This is implemented by an AGC loop which reduces the preamplifier feedback resistance so that the amplifier remains linear over the whole input range. The AGC loop hold capacitor is integrated on-chip, so an external capacitor is not required.

The bandwidth of TZA3026 is optimized for STM4/OC12 application. It works from DC onward due to the absence of offset control loops. Therefore the amount of Consecutive Identical Digits (CID) will not effect the output waveform. A differential amplifier converts the output of the preamplifier to a differential voltage.

### 7.1 PIN diode connections

The performance of an optical receiver is largely determined by the combined effect of the transimpedance amplifier and the PIN diode. In particular, the method used to connect the PIN diode to the input (pad IPHOTO) and the layout around the input pad strongly influences the main parameters of a transimpedance amplifier, such as sensitivity, bandwidth, and PSRR.

Sensitivity is most affected by the value of the total capacitance at the input pad. Therefore, to obtain the highest possible sensitivity the total capacitance should be as low as possible.

The parasitic capacitance can be minimized through:

1. Reducing the capacitance of the PIN diode. This is achieved by proper choice of PIN diode and typically a high reverse voltage.
2. Reducing the parasitics around the input pad. This is achieved by placing the PIN diode as close as possible to the TIA.

The PIN diode can be biased with a positive or a negative voltage. [Figure 3](#) shows the PIN diode biased positively, using the on-chip bias pad DREF. The voltage at DREF is derived from  $V_{CC}$  by a low-pass filter comprising internal resistor  $R_{DREF}$  and external capacitor  $C2$  which decouples any supply voltage noise. The value of external capacitor  $C2$  affects the value of PSRR and should have a minimum value of 470 pF. Increasing this value improves the value of PSRR. The current through  $R_{DREF}$  is measured and sourced at pad IDREF\_MON, see [Section 7.3](#).

If the biasing for the PIN diode is done external to the IC, pad DREF can be left unconnected. If a negative bias voltage is used, the configuration shown in [Figure 4](#) can be used. In this configuration, the direction of the signal current is reversed to that shown in [Figure 3](#). It is essential that in these applications, the PIN diode bias voltage is filtered to achieve the best sensitivity.

For maximum freedom on bonding location, 2 outputs are available for DREF (pads 1 and 3). These are internally connected. Both outputs can be used if necessary. If only one is used, the other can be left open.

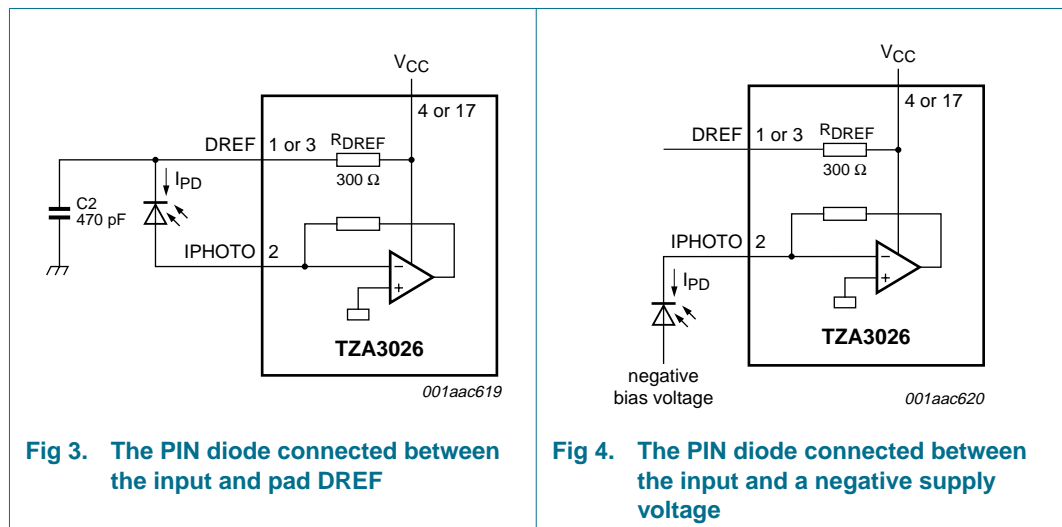

### 7.2 Automatic gain control

The TZA3026 transimpedance amplifier can handle input currents from 0.85  $\mu\text{A}$  to 1.5 mA which is equivalent to a dynamic range of 65 dB (electrical equivalent with 32.5 dB optical). At low input currents, the transimpedance must be high to obtain enough output voltage, and the noise should be low enough to guarantee a minimum bit error rate. At high input currents however, the transimpedance should be low to prevent excessive distortion at the output stage. To achieve the dynamic range, the gain of the amplifier depends on the level of the input signal. This is achieved in the TZA3026 by an AGC loop.

The AGC loop comprises a peak detector and a gain control circuit. The peak detector detects the amplitude of the signal and stores it on a hold capacitor. The hold capacitor voltage is compared to a threshold voltage. The AGC is only active when the input signal level is larger than the threshold level and is inactive when the input signal is smaller than the threshold level.

When the AGC is inactive, the transimpedance is at its maximum. When the AGC is active, the feedback resistor value of the transimpedance amplifier is reduced, reducing its transimpedance, to keep the output voltage constant. [Figure 5](#) shows the transimpedance as function of the input current.

To reduce sensitivity to offsets and output loads, the AGC detector senses the output just before the output buffer. [Figure 6](#) shows the AGC voltage as function of the input current.

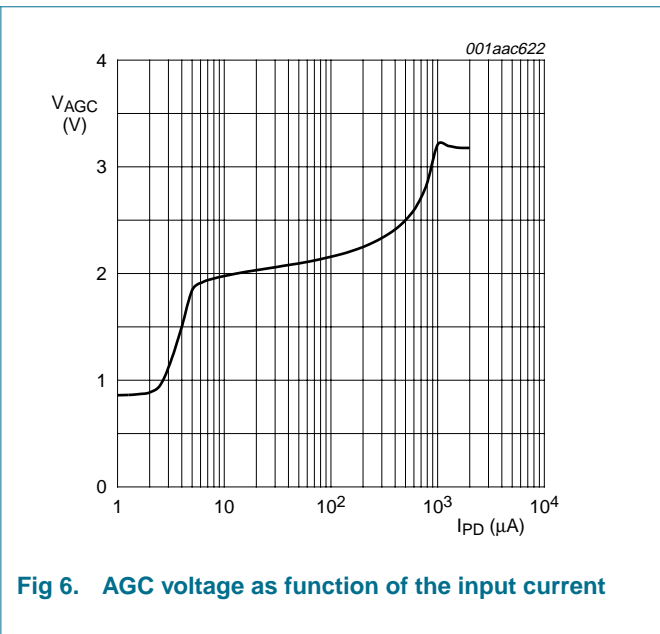
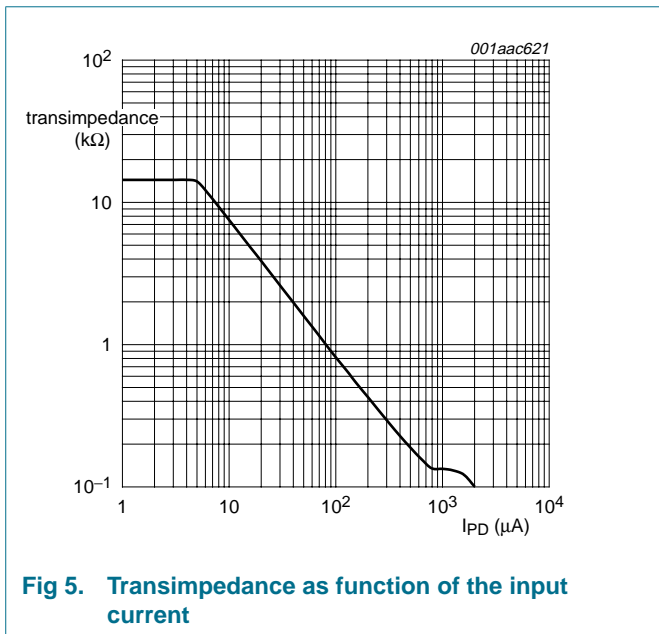

For applications where the transimpedance is controlled by the TIA it is advised to leave the AGC pads unconnected to achieve fast attack and decay times.

The AGC function can be overruled by applying a voltage to pad AGC. In this configuration, connecting pad AGC to ground gives maximum transimpedance and connecting it to  $V_{CC}$  gives minimum transimpedance. This is depicted in [Figure 7](#). The AGC voltage should be derived from the  $V_{CC}$  for proper functioning.

For maximum freedom on bonding location, 2 pads are available for AGC (pads 6 and 15). These pads are internally connected. Both pads can be used if necessary.

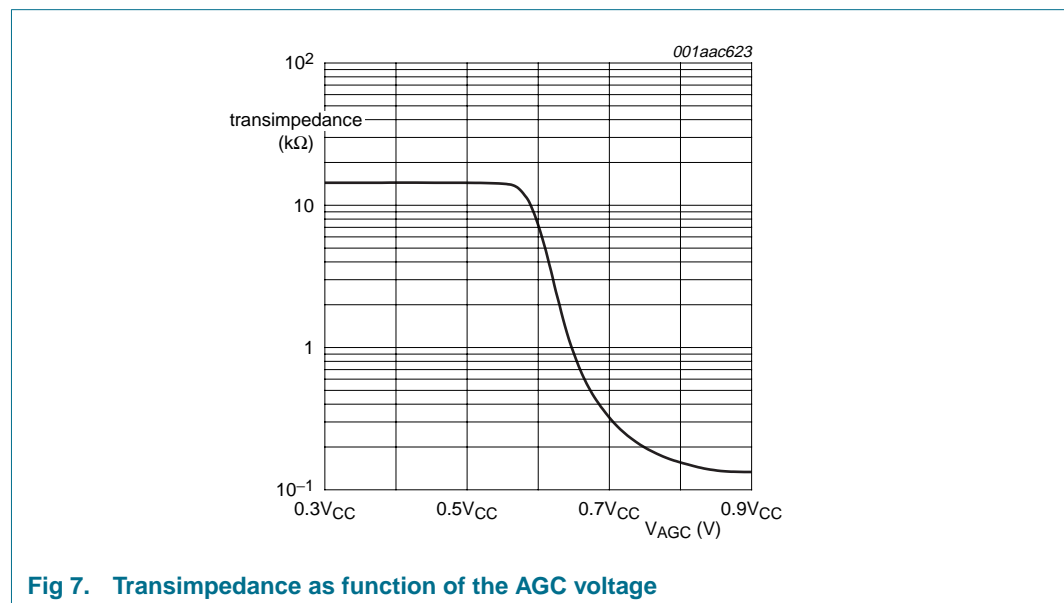

### 7.3 Monitoring RSSI via IDREF\_MON

To facilitate RSSI monitoring in modules (e.g. SFF8472 compliant SFP modules), a current output is provided. This output gives a current which is 20 % of the average DREF current through the 300 Ω bias resistor. By connecting a resistor to the IDREF\_MON output, a voltage proportional with the average input power can be obtained.

The RSSI monitoring is implemented by measuring the voltage over the 300 Ω bias resistor. This method is preferred over simple current mirror because at small photo currents the voltage drop over the resistor is very small. This gives a higher bias voltage yielding better performance of the photodiode.

For maximum freedom on bonding location, 2 pads are available for IDREF\_MON (pads 5 and 16). These pads are internally connected. Both pads can be used if necessary. If only one is used, the other can be left open.

## 8. Limiting values

**Table 3: Limiting values**

In accordance with the Absolute Maximum Rating System (IEC 60134).

Symbol	Parameter	Conditions	Min	Max	Unit
$V_{CC}$	supply voltage		-0.5	+3.8	V
$V_n$	pad DC voltage	pad			
		IPHOTO	-0.5	+2.0	V
		OUT, OUTQ	-0.5	$V_{CC} + 0.5$	V
		AGC, IDREF_MON	-0.5	$V_{CC} + 0.5$	V
		DREF	-0.5	$V_{CC} + 0.5$	V
$I_n$	pad DC current	pad			
		IPHOTO	-4.0	+4.0	mA
		OUT, OUTQ	-10	+10	mA
		AGC, IDREF_MON	-0.2	+0.2	mA
		DREF	-4.0	+4.0	mA
$P_{tot}$	total power dissipation		-	300	mW
$T_{amb}$	ambient temperature		-40	+85	°C
$T_j$	junction temperature		-	150	°C
$T_{stg}$	storage temperature		-65	+150	°C

## 9. Characteristics

**Table 4: Characteristics**

Typical values at  $T_j = 25\text{ °C}$  and  $V_{CC} = 3.3\text{ V}$ ; minimum and maximum values are valid over the entire ambient temperature range and supply voltage range; all voltages are measured with respect to ground; unless otherwise specified.

Symbol	Parameter	Conditions	Min	Typ	Max	Unit
$V_{CC}$	supply voltage		2.9	3.3	3.6	V
$I_{CC}$	supply current	AC-coupled; $R_{L(dif)} = 100\ \Omega$ ; excluding $I_{DREF}$ and $I_{IDREF\_MON}$	-	18	21	mA
$P_{tot}$	total power dissipation		-	60	76	mW
$T_j$	junction temperature		-40	-	+125	°C
$T_{amb}$	ambient temperature		-40	+25	+85	°C
$R_{tr}$	small-signal transresistance of the receiver	measured differentially; AC-coupled, $R_{L(dif)} = 100\ \Omega$	9.5	14	19	k $\Omega$
$f_{-3dB(h)}$	high frequency -3 dB point	$C_{PD} = 0.7\text{ pF}$ ; $V_{CC} = 3.3\text{ V}$	440	650	-	MHz
$I_{n(tot)(rms)}$	total integrated RMS noise current over bandwidth	referenced to input; $C_{PD} = 0.7\text{ pF}$ ; $\Delta f_i = 450\text{ MHz}$ third-order Bessel filter	<a href="#">1</a> -	67	79	nA

### Automatic gain control loop: pad AGC

$t_{att}$	attack time	AGC pad unconnected	-	14	-	$\mu\text{s}$
$t_{decay}$	decay time	AGC pad unconnected	-	40	-	$\mu\text{s}$
$V_{O(data)(p-p)}$	data output voltage (peak-to-peak value)	referenced to output; measured differentially	-	125	-	mV



**Table 4: Characteristics ...continued**

Typical values at  $T_j = 25\text{ °C}$  and  $V_{CC} = 3.3\text{ V}$ ; minimum and maximum values are valid over the entire ambient temperature range and supply voltage range; all voltages are measured with respect to ground; unless otherwise specified.

Symbol	Parameter	Conditions	Min	Typ	Max	Unit
<b>Bias voltage: pad DREF</b>						
$R_{DREF}$	resistance between pad DREF and pad $V_{CC}$	tested at DC level; $T_{amb} = 25\text{ °C}$	250	300	350	$\Omega$
$TC_{RDREF}$	temperature coefficient $R_{DREF}$		-	0.33	-	$\Omega/^\circ\text{C}$
<b>Input: pad IPHOTO</b>						
$I_{PD(p-p)}$	input current (peak-to-peak value)		[2] -1500	-	+1500	$\mu\text{A}$
$V_{bias}$	input bias voltage		700	850	1000	mV
<b>Monitor: pad IDREF_MON</b>						
$V_{MON}$	monitor voltage		[1] 0	-	$V_{CC} - 0.4$	V
$A_{MON}$	monitor current ratio	ratio $I_{DREF\_MON} / I_{DREF}$	19.5	20	20.5	%
$I_{MON(offset)}$	monitor offset current	$T_{amb} = 25\text{ °C}$	0	10	20	$\mu\text{A}$
$TC_{MON(offset)}$	temperature coefficient monitor offset current		-	30	-	$\text{nA}/^\circ\text{C}$
<b>Data outputs: pads OUT and OUTQ</b>						
$V_{o(cm)}$	common mode output voltage	AC-coupled; $R_{L(dif)} = 100\ \Omega$	-	$V_{CC} - 1.2$	-	V
$V_{o(dif)(p-p)}$	differential load output voltage (peak-to-peak value)	AC-coupled; $R_{L(dif)} = 100\ \Omega$				
		$I_{PD} = 0.84\ \mu\text{A (p-p)} \times R_{tr}$	8	12	-	mV
		$I_{PD} = 100\ \mu\text{A (p-p)}$	-	125	-	mV
		$I_{PD} = 1500\ \mu\text{A (p-p)}$	-	250	500	mV
$R_{O(dif)}$	differential output resistance	tested at DC level	-	100	-	$\Omega$
$t_r$	rise time	20 % to 80 %; $I_{PD} = 100\ \mu\text{A (p-p)}$	-	300	-	ps
$t_f$	fall time	80 % to 20 %; $I_{PD} = 100\ \mu\text{A (p-p)}$	-	300	-	ps

[1] Guaranteed by design.

[2] The input current range is determined by the allowed Pulse Width Distortion (PWD), which is <5 % over the whole input current range.

The PWD is defined as:  $PWD = \left( \frac{\text{pulse width}}{T} - (0.5) \right) \times 100\%$ , where T is the clock period.

## 10. Application information

For maximum freedom on bonding location, 2 outputs are available for OUT and OUTQ. The outputs should be used in pairs: pad 14 with pad 7 or pad 8 with pad 13. Pad 8 is internally connected with pad 14, pad 7 is internally connected with pad 13. The device is guaranteed with only one pair used. The other pair should be left open. Two examples of the bonding possibilities are shown in [Figure 8](#).

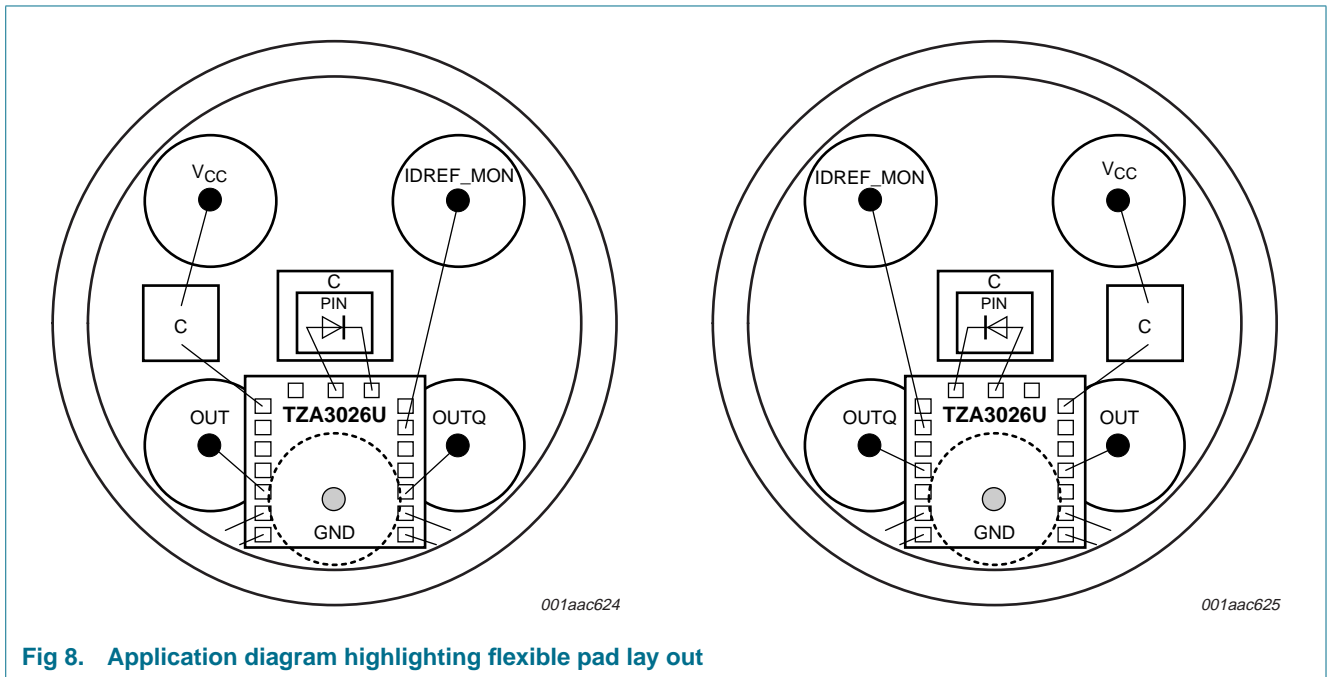

11. Test information

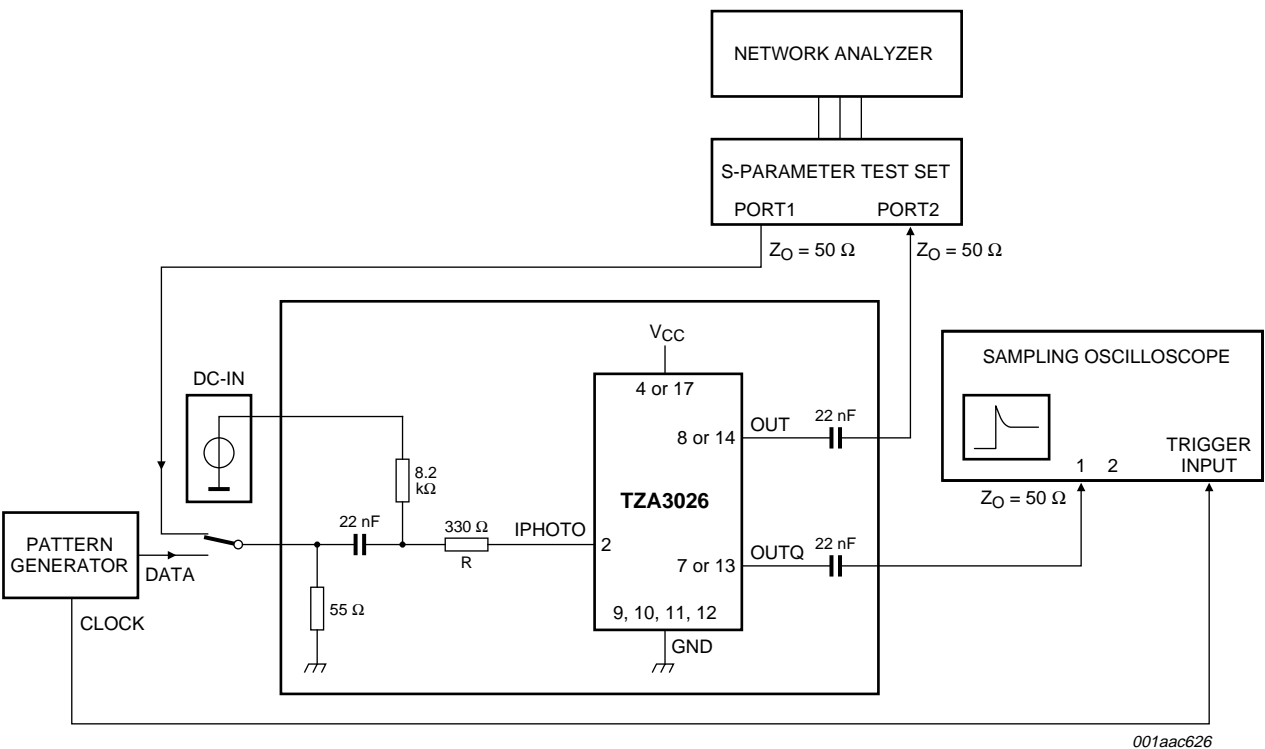

Total impedance of the test circuit ( $Z_T$ ) is calculated by the equation  $Z_T = s_{21} \times (R + Z_{IN}) \times 2$ , where  $s_{21}$  is the insertion loss of ports 1 and 2.  
 Typical values:  $R = 330 \Omega$ ,  $Z_{IN} = 75 \Omega$ .

Fig 9. Test circuit

## 12. Bare die information

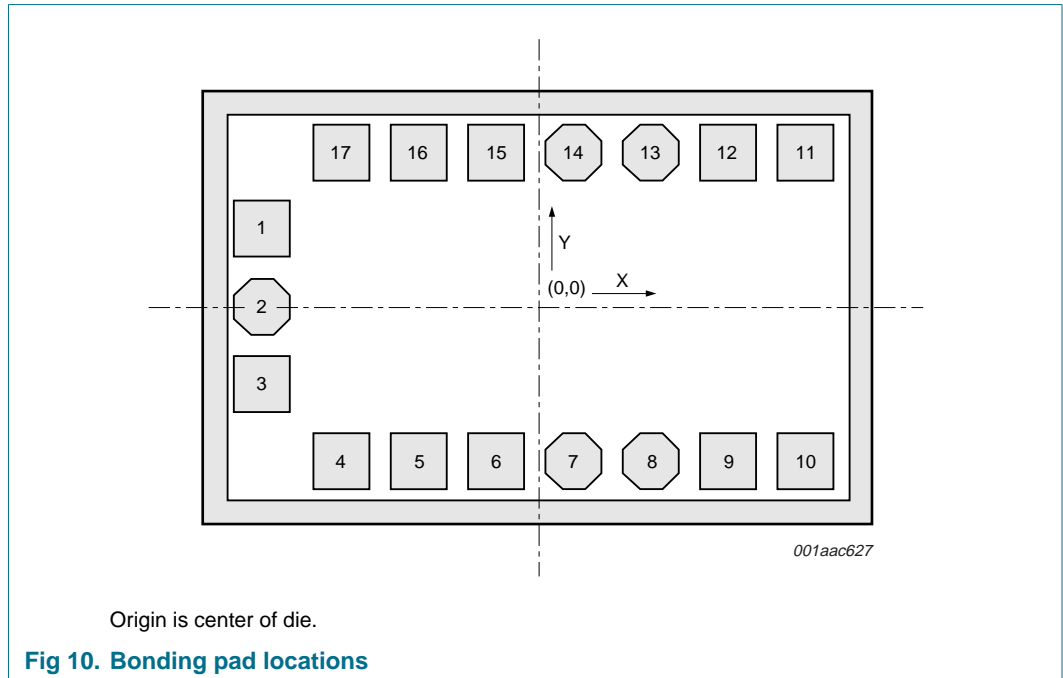

**Table 5: Physical characteristics of the bare die**

Parameter	Value
Glass passivation	0.3 $\mu\text{m}$ PSG (PhosphoSilicate Glass) on top of 0.8 $\mu\text{m}$ silicon nitride
Bonding pad dimension	minimum dimension of exposed metallization is 90 $\mu\text{m}$ $\times$ 90 $\mu\text{m}$ (pad size = 100 $\mu\text{m}$ $\times$ 100 $\mu\text{m}$ ) except pads 2 and 3 which have exposed metallization of 80 $\mu\text{m}$ $\times$ 80 $\mu\text{m}$ (pad size = 90 $\mu\text{m}$ $\times$ 90 $\mu\text{m}$ )
Metallization	2.8 $\mu\text{m}$ AlCu
Thickness	380 $\mu\text{m}$ nominal
Die dimension	820 $\mu\text{m}$ $\times$ 1300 $\mu\text{m}$ ( $\pm$ 20 $\mu\text{m}^2$ )
Backing	silicon; electrically connected to GND potential through substrate contacts
Attach temperature	<440 $^{\circ}\text{C}$ ; recommended die attach is glue
Attach time	<15 s

## 13. Package outline

Not applicable.

## 14. Handling information

### 14.1 General

Inputs and outputs are protected against electrostatic discharge in normal handling. However, to be completely safe, it is desirable to take normal precautions appropriate to handling MOS devices; see *JESD625-A* and/or *IEC61340-5*.

### 14.2 Additional information

Pad IPHOTO has limited protection to ensure good RF performance. This pad should be handled with extreme care.

## 15. Revision history

Table 6: Revision history

Document ID	Release date	Data sheet status	Change notice	Doc. number	Supersedes
TZA3026_1	20050502	Product data sheet	-	9397 750 14763	-

## 16. Data sheet status

Level	Data sheet status <sup>[1]</sup>	Product status <sup>[2] [3]</sup>	Definition
I	Objective data	Development	This data sheet contains data from the objective specification for product development. Philips Semiconductors reserves the right to change the specification in any manner without notice.
II	Preliminary data	Qualification	This data sheet contains data from the preliminary specification. Supplementary data will be published at a later date. Philips Semiconductors reserves the right to change the specification without notice, in order to improve the design and supply the best possible product.
III	Product data	Production	This data sheet contains data from the product specification. Philips Semiconductors reserves the right to make changes at any time in order to improve the design, manufacturing and supply. Relevant changes will be communicated via a Customer Product/Process Change Notification (CPCN).

[1] Please consult the most recently issued data sheet before initiating or completing a design.

[2] The product status of the device(s) described in this data sheet may have changed since this data sheet was published. The latest information is available on the Internet at URL <http://www.semiconductors.philips.com>.

[3] For data sheets describing multiple type numbers, the highest-level product status determines the data sheet status.

## 17. Definitions

**Short-form specification** — The data in a short-form specification is extracted from a full data sheet with the same type number and title. For detailed information see the relevant data sheet or data handbook.

**Limiting values definition** — Limiting values given are in accordance with the Absolute Maximum Rating System (IEC 60134). Stress above one or more of the limiting values may cause permanent damage to the device. These are stress ratings only and operation of the device at these or at any other conditions above those given in the Characteristics sections of the specification is not implied. Exposure to limiting values for extended periods may affect device reliability.

**Application information** — Applications that are described herein for any of these products are for illustrative purposes only. Philips Semiconductors make no representation or warranty that such applications will be suitable for the specified use without further testing or modification.

**Right to make changes** — Philips Semiconductors reserves the right to make changes in the products - including circuits, standard cells, and/or software - described or contained herein in order to improve design and/or performance. When the product is in full production (status 'Production'), relevant changes will be communicated via a Customer Product/Process Change Notification (CPCN). Philips Semiconductors assumes no responsibility or liability for the use of any of these products, conveys no license or title under any patent, copyright, or mask work right to these products, and makes no representations or warranties that these products are free from patent, copyright, or mask work right infringement, unless otherwise specified.

**Bare die** — All die are tested and are guaranteed to comply with all data sheet limits up to the point of wafer sawing for a period of ninety (90) days from the date of Philips' delivery. If there are data sheet limits not guaranteed, these will be separately indicated in the data sheet. There are no post packing tests performed on individual die or wafer. Philips Semiconductors has no control of third party procedures in the sawing, handling, packing or assembly of the die. Accordingly, Philips Semiconductors assumes no liability for device functionality or performance of the die or systems after third party sawing, handling, packing or assembly of the die. It is the responsibility of the customer to test and qualify their application in which the die is used.

## 18. Disclaimers

**Life support** — These products are not designed for use in life support appliances, devices, or systems where malfunction of these products can reasonably be expected to result in personal injury. Philips Semiconductors customers using or selling these products for use in such applications do so at their own risk and agree to fully indemnify Philips Semiconductors for any damages resulting from such application.

## 19. Trademarks

**Notice** — All referenced brands, product names, service names and trademarks are the property of their respective owners.

## 20. Contact information

For additional information, please visit: <http://www.semiconductors.philips.com>

For sales office addresses, send an email to: [sales.addresses@www.semiconductors.philips.com](mailto:sales.addresses@www.semiconductors.philips.com)

## 21. Contents

<b>1</b>	<b>General description</b> .....	<b>1</b>
<b>2</b>	<b>Features</b> .....	<b>1</b>
<b>3</b>	<b>Applications</b> .....	<b>1</b>
<b>4</b>	<b>Ordering information</b> .....	<b>1</b>
<b>5</b>	<b>Block diagram</b> .....	<b>2</b>
<b>6</b>	<b>Pinning information</b> .....	<b>3</b>
6.1	Pinning .....	3
6.2	Pin description .....	3
<b>7</b>	<b>Functional description</b> .....	<b>4</b>
7.1	PIN diode connections .....	4
7.2	Automatic gain control .....	6
7.3	Monitoring RSSI via IDREF_MON .....	7
<b>8</b>	<b>Limiting values</b> .....	<b>8</b>
<b>9</b>	<b>Characteristics</b> .....	<b>8</b>
<b>10</b>	<b>Application information</b> .....	<b>10</b>
<b>11</b>	<b>Test information</b> .....	<b>11</b>
<b>12</b>	<b>Bare die information</b> .....	<b>12</b>
<b>13</b>	<b>Package outline</b> .....	<b>12</b>
<b>14</b>	<b>Handling information</b> .....	<b>13</b>
14.1	General .....	13
14.2	Additional information .....	13
<b>15</b>	<b>Revision history</b> .....	<b>13</b>
<b>16</b>	<b>Data sheet status</b> .....	<b>14</b>
<b>17</b>	<b>Definitions</b> .....	<b>14</b>
<b>18</b>	<b>Disclaimers</b> .....	<b>14</b>
<b>19</b>	<b>Trademarks</b> .....	<b>14</b>
<b>20</b>	<b>Contact information</b> .....	<b>14</b>



© Koninklijke Philips Electronics N.V. 2005

All rights are reserved. Reproduction in whole or in part is prohibited without the prior written consent of the copyright owner. The information presented in this document does not form part of any quotation or contract, is believed to be accurate and reliable and may be changed without notice. No liability will be accepted by the publisher for any consequence of its use. Publication thereof does not convey nor imply any license under patent- or other industrial or intellectual property rights.

Date of release: 2 May 2005  
Document number: 9397 750 14763

Published in The Netherlands