

DATA SHEET

TZA3013A; TZA3013B **SDH/SONET STM16/OC48** **transimpedance amplifier**

Product specification
Supersedes data of 2000 Jun 19
File under Integrated Circuits, IC19

2001 Feb 26

**SDH/SONET STM16/OC48
transimpedance amplifier**

TZA3013A; TZA3013B

FEATURES

- Low equivalent input noise, typically 8 pA/√Hz
- Wide dynamic range, typically 6 μA to 1.7 mA (p-p)
- Differential transimpedance of 4 kΩ
- Bandwidth from DC to 1.9 GHz
- Differential outputs
- On-chip Automatic Gain Control (AGC)
- No external components required
- Single supply voltage 3.3 V
- Bias voltage for PIN diode
- Remains linear up to 1.7 mA (p-p) input current (unclipped)
- Switched output polarity available (types A and B).

APPLICATIONS

- Digital fibre optic receiver in short, medium and long haul optical telecommunications transmission systems or in high speed data networks
- Wide-band RF gain block.

GENERAL DESCRIPTION

The TZA3013 is a transimpedance amplifier with AGC, designed to be used in STM16/OC48 fibre-optic links. It amplifies the current generated by a photo detector (PIN diode or avalanche photodiode) and converts it to a differential output voltage.

ORDERING INFORMATION

TYPE NUMBER	PACKAGE		
	NAME	DESCRIPTION	VERSION
TZA3013AU	–	bare die in waffle pack carriers; die dimensions 0.810 × 1.230 mm	–
TZA3013BU	–	bare die in waffle pack carriers; die dimensions 0.810 × 1.230 mm	–

SDH/SONET STM16/OC48 transimpedance amplifier

TZA3013A; TZA3013B

BLOCK DIAGRAM

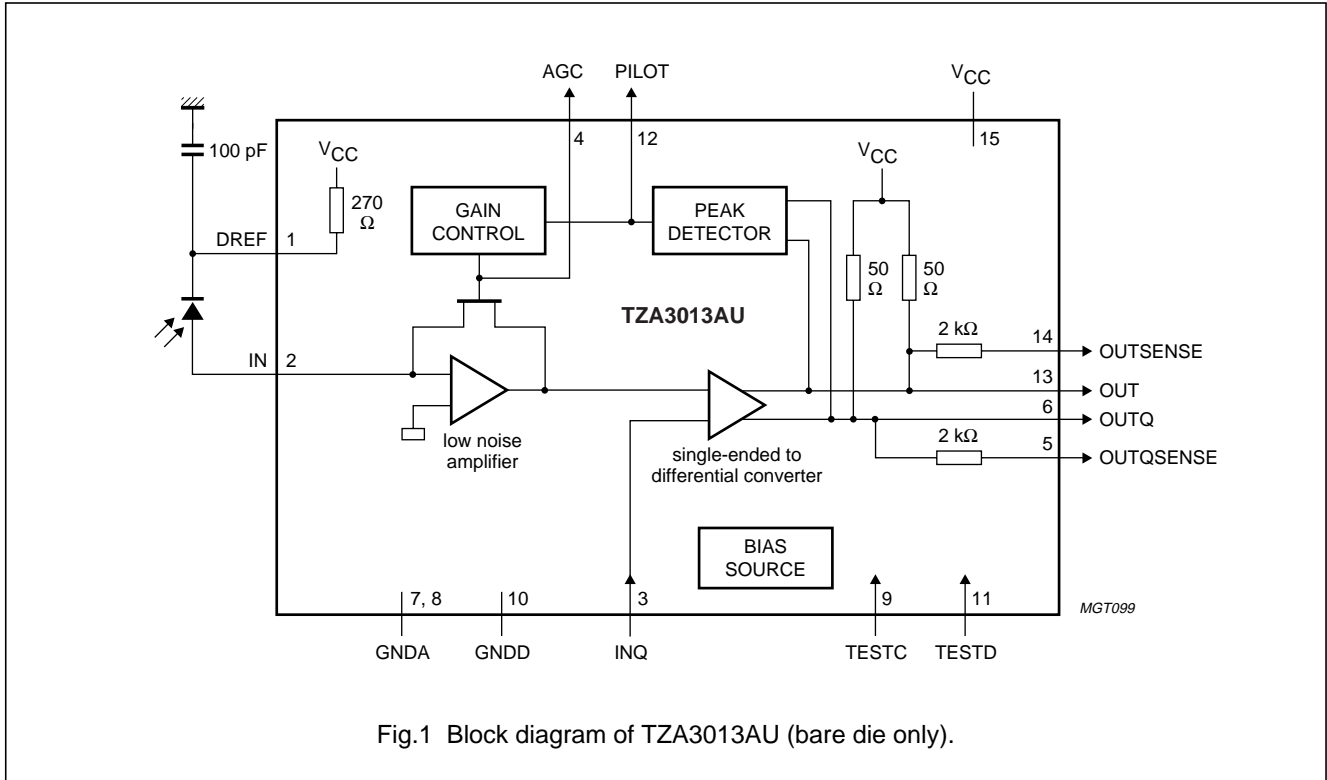

Fig.1 Block diagram of TZA3013AU (bare die only).

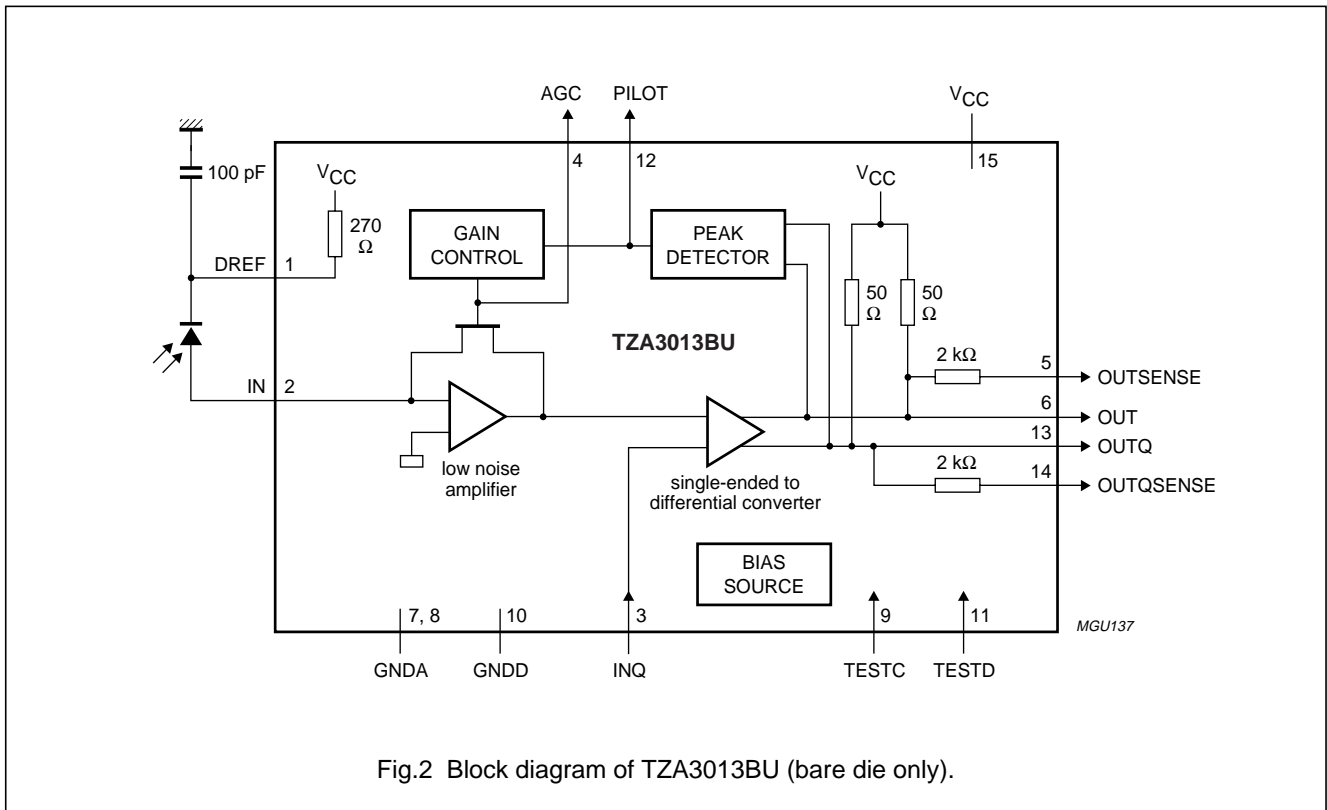

Fig.2 Block diagram of TZA3013BU (bare die only).

SDH/SONET STM16/OC48 transimpedance amplifier

TZA3013A; TZA3013B

PINNING

SYMBOL	PAD TZA3013AU	PAD TZA3013BU	TYPE	DESCRIPTION
DREF	1	1	analog output	bias voltage output for PIN diode; connect cathode of PIN diode to this pad
IN	2	2	input	current input; anode of PIN diode should be connected to this pad; note 1
INQ	3	3	input	decision level adjust input; note 1
AGC	4	4	analog output	AGC voltage
OUTQSENSE	5	14	analog output	data sense output for OUTQ; for test purposes
OUTQ	6	13	output	data output; compliment of OUT
GNDA	7	7	ground	analog ground
GNDA	8	8	ground	analog ground
TESTC	9	9	input	test input; not used in the application
GNDD	10	10	ground	digital ground
TESTD	11	11	input	test input; not used in the application
PILOT	12	12	analog output	pilot tone detection current output
OUT	13	6	output	data output; compliment of OUTQ; note 2
OUTSENSE	14	5	analog output	data sense output for OUT; for test purposes
V _{CC}	15	15	supply	supply voltage

Notes

- DC bias voltage = 0.86 V.
- This pad goes HIGH when current flows into pad IN.

**SDH/SONET STM16/OC48
transimpedance amplifier**

TZA3013A; TZA3013B

FUNCTIONAL DESCRIPTION

The TZA3013 is a transimpedance amplifier intended for use in fibre optic links for signal recovery in STM16/OC48 applications. It amplifies the current generated by a photo detector (PIN diode or avalanche photodiode) and converts it to a differential output voltage.

The most important characteristics of the TZA3013 are high receiver sensitivity and wide dynamic range. High receiver sensitivity is achieved by minimizing transimpedance amplifier noise.

The TZA3013 has a wide dynamic range to handle the signal current generated by the PIN diode which can vary from 6 μ A to 1.7 mA (p-p). This is implemented by an AGC loop which reduces the preamplifier feedback resistance so that the amplifier remains linear over the whole input range. The AGC loop hold capacitor is integrated on-chip, so an external capacitor is not required.

A differential amplifier converts the output of the preamplifier to a differential voltage. The data output circuit is shown in Fig.3.

The logic level symbol definitions are shown in Fig.4.

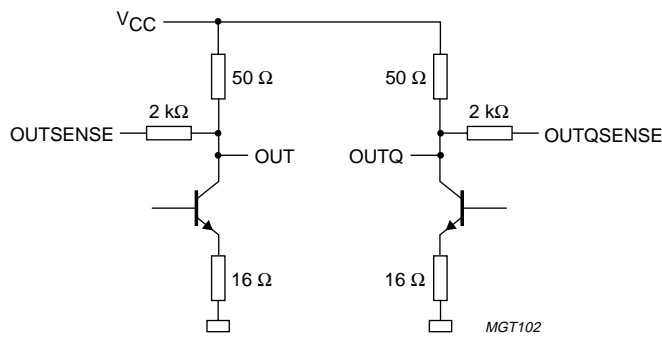

Fig.3 Data output circuit.

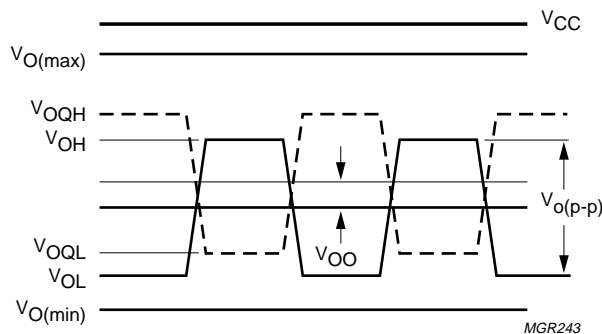

Fig.4 Logic level symbol definitions for data outputs OUT and OUTQ.

SDH/SONET STM16/OC48 transimpedance amplifier

TZA3013A; TZA3013B

PIN diode bias voltage DREF

The performance of an optical receiver is largely determined by the combined effect of the transimpedance amplifier and the PIN diode. In particular, the method used to connect the PIN diode to the input and the layout around the input pad strongly influences the main parameters of a transimpedance amplifier, such as sensitivity, bandwidth, and PSRR. Sensitivity is most affected by the value of the total capacitance at the input pad. Therefore, to obtain the highest possible sensitivity requires the value of total capacitance to be as low as possible by reducing the capacitance of the PIN diode and the parasitics around the input pad. To minimize parasitics, the PIN diode should be placed as close as physically possible to the IC. The capacitance of the PIN diode can be reduced by making the value of reverse voltage across it as high as possible.

The PIN diode can be connected to the input in two ways. Figure 5 shows the PIN diode connected between pads DREF and IN.

Pad DREF provides an easy bias voltage for the PIN diode. The voltage at DREF is derived from V_{CC} by a low-pass filter comprising internal resistor R1 and external capacitor C2 which decouples any supply voltage noise. The value of external capacitor C2 affects the value of PSRR and should have a minimum value of 100 pF. Increasing this value increases the value of PSRR.

For a supply voltage of 3.3 V, the reverse voltage across the PIN diode is 2.438 V ($3.3\text{ V} - 0.862\text{ V}$). It is preferable to connect the cathode of the PIN diode to a voltage higher than V_{CC} if there is one available on the PCB, leaving pad DREF unconnected. If a negative supply voltage is available, the configuration shown in Fig.6 can be used. It should be noted that in this configuration, the direction of the signal current is reversed to that shown in Fig.5. It is essential that the PIN diode bias voltage is correctly filtered to achieve the highest possible level of sensitivity.

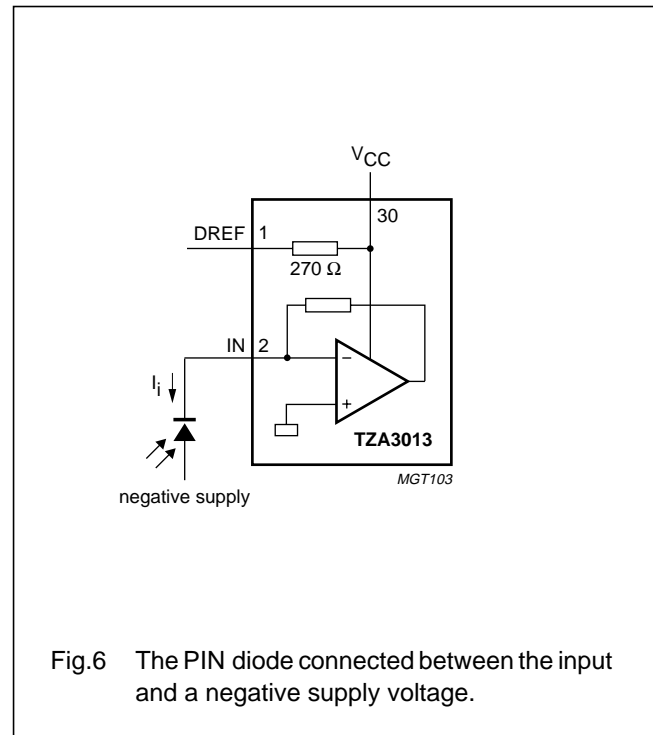
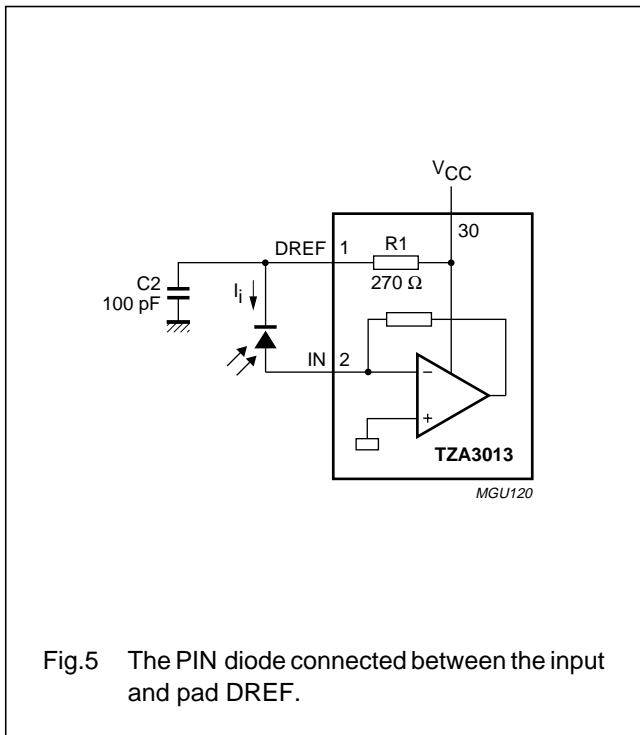

SDH/SONET STM16/OC48 transimpedance amplifier

TZA3013A; TZA3013B

AGC

The TZA3013 transimpedance amplifier can handle input currents from 6 μA to 1.7 mA which is equivalent to a dynamic range of 49 dB. At low input currents, the transimpedance must be high to obtain enough output voltage, and the noise should be low enough to guarantee a minimum bit error rate. At high input currents however, the transimpedance should be low to avoid pulse width distortion. To achieve the wide dynamic range requires the gain of the amplifier to depend on the level of the input signal. This is achieved in the TZA3013 by an AGC loop.

The AGC loop comprises a peak detector, a hold capacitor and a gain control circuit. The peak detector detects the amplitude of the signal and the hold capacitor stores it. The hold capacitor voltage is compared to a threshold voltage which corresponds to an input current of 50 μA (p-p). The AGC is only active when the input signal level is larger than the threshold level and is inactive when the input signal is smaller than the threshold level.

When the AGC is inactive, the transimpedance is at its maximum value of 4 k Ω differential. When the AGC is active, the feedback resistor value of the transimpedance amplifier is reduced, reducing its transimpedance, to keep the output voltage constant. The transimpedance is regulated from 4 k Ω at low currents ($I_i < 50 \mu\text{A}$) to 80 Ω at high currents ($I_i = 1.7\text{mA}$). The AGC allows the amplifier to remain linear over the whole input current range compared to other configurations which clip the large signals, such as those using Schottky diodes, for example.

The top half of Fig.7 shows the output voltage at pads OUT and OUTQ (V_{OUT} and V_{OUTQ}) as a function of DC input current (I_i) at a supply voltage of 3.3 V. The bottom half of Fig.7 shows the difference between V_{OUT} and V_{OUTQ} . The output voltage changes linearly up to an input current of 50 μA . At this point and above, the AGC becomes active and tries to keep the differential output voltage constant, which is about 220 mV for a large range input current of <1.7 mA.

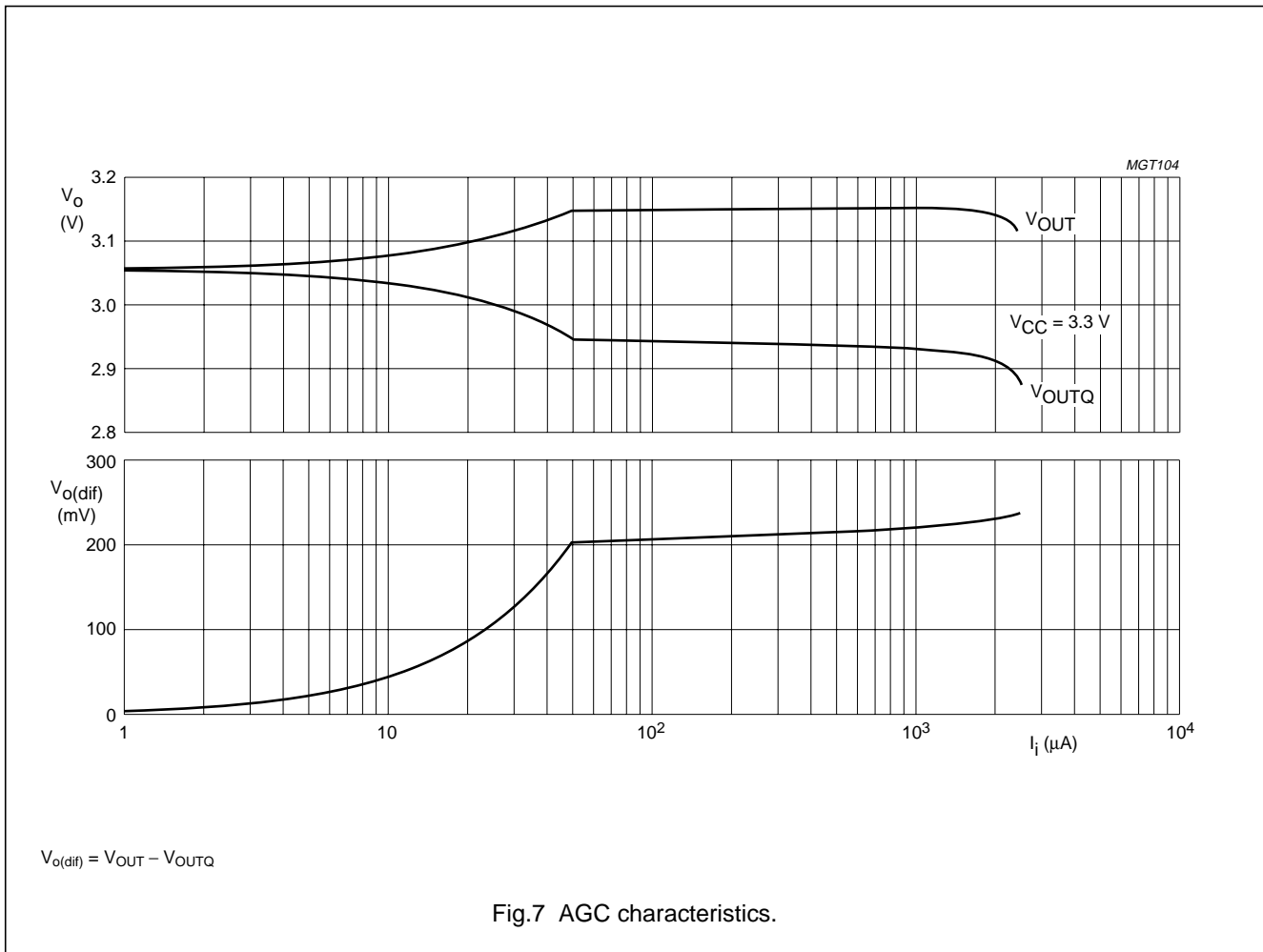

SDH/SONET STM16/OC48 transimpedance amplifier

TZA3013A; TZA3013B

LIMITING VALUES

In accordance with the Absolute Maximum Rating System (IEC 60134).

SYMBOL	PARAMETER	MIN.	MAX.	UNIT
V_{CC}	supply voltage	-0.5	+3.8	V
V_n	DC voltage			
	pads IN and INQ	-0.5	+2.0	V
	pads OUT and OUTQ	-0.5	$V_{CC} + 0.5$	V
	pads OUTSENSE and OUTQSENSE	-0.5	$V_{CC} + 0.5$	V
	pad PILOT	-0.5	$V_{CC} + 0.5$	V
	pad DREF	-0.5	$V_{CC} + 0.5$	V
I_n	DC current			
	pads IN and INQ	-4.0	+4.0	mA
	pads OUT and OUTQ	-10	+10	mA
	pad PILOT	-0.2	+0.2	mA
	pad DREF	-4.0	+4.0	mA
P_{tot}	total power dissipation	-	300	mW
T_{stg}	storage temperature	-65	+150	°C
T_j	junction temperature	-	150	°C
T_{amb}	ambient temperature	-40	+85	°C

HANDLING

Inputs and outputs are protected against electrostatic discharge in normal handling. However it is good practice to take normal precautions appropriate to handling MOS devices (see "Handling MOS devices").

CHARACTERISTICS

Typical values at $T_j = 25\text{ °C}$ and $V_{CC} = 3.3\text{ V}$; minimum and maximum values are valid over the entire ambient temperature range and supply range; all voltages are measured with respect to ground; unless otherwise specified.

SYMBOL	PARAMETER	CONDITIONS	MIN.	TYP.	MAX.	UNIT
V_{CC}	supply voltage		3.0	3.3	3.6	V
I_{CC}	supply current	AC-coupled; $R_L = 50\ \Omega$; without input signal	-	26	38	mA
P_{tot}	total power dissipation	$V_{CC} = 3.3\text{ V}$	-	85.8	134	mW
T_j	junction temperature		-40	-	+125	°C
T_{amb}	ambient temperature		-40	+25	+85	°C
R_{tr}	small-signal transresistance of the receiver	measured differentially; AC-coupled				
		$R_L = \infty$	3.6	7	10	k Ω
		$R_L = 50\ \Omega$	1.8	3.5	5.0	k Ω
$f_{-3dB(h)}$	high frequency -3 dB point	$C_i = 0.5\text{ pF}$	1.7	1.9	-	GHz
$I_{n(tot)(rms)}$	total integrated RMS noise current over bandwidth	referenced to input; $\Delta f_i = 1.8\text{ GHz}$ third-order Bessel filter; note 1	-	425	-	nA

SDH/SONET STM16/OC48 transimpedance amplifier

TZA3013A; TZA3013B

SYMBOL	PARAMETER	CONDITIONS	MIN.	TYP.	MAX.	UNIT
PSRR	power supply rejection ratio	measured differentially; note 2				
		$f_i = 100 \text{ kHz to } 100 \text{ MHz}$	–	38	–	$\mu\text{A/V}$
		$f_i = 3 \text{ GHz}$	–	3.2	–	mA/V
Automatic gain control loop: AGC						
t_{att}	AGC attack time		–	10	–	μs
t_{decay}	AGC decay time		–	10	–	μs
$I_{\text{th(AGC)(p-p)}}$	AGC threshold current (peak-to-peak value)	referenced to input	–	50	–	μA
Bias voltage: DREF						
R_{DREF}	resistance between DREF and V_{CC}	tested at DC level	240	270	340	Ω
Inputs: IN and INQ						
$I_{i(p-p)}$	input current (peak-to-peak value)		–1700	–	+1700	μA
$V_{i(\text{bias})}$	input bias voltage		700	860	1100	mV
R_i	small-signal input resistance	tested at 1 MHz; $I_i < 20 \mu\text{A}$ (p-p)	–	53	–	Ω
Data outputs: OUT and OUTQ						
$V_{o(\text{cm})}$	common mode output voltage	AC-coupled; $R_L = 50 \Omega$	$V_{\text{CC}} - 0.5$	$V_{\text{CC}} - 0.25$	$V_{\text{CC}} - 0.1$	V
$V_{o(\text{se})(p-p)}$	single-ended load output voltage (peak-to-peak value)	AC-coupled; $R_L = 50 \Omega$; $I_i = 100 \mu\text{A}$ (p-p)	45	110	200	mV
V_{OO}	differential output offset voltage		–100	0	+100	mV
R_o	output resistance	single-ended; DC tested	40	53	65	Ω
t_r	rise time	20% to 80%	–	200	–	ps
t_f	fall time	80% to 20%	–	200	–	ps

Notes

- Measurement performed with $C_i = 0.5 \text{ pF}$ comprising 0.4 pF (photodiode) and 0.1 pF (allowed for PCB layout).
- PSRR is defined as the ratio of change in input current (ΔI_i) corresponding to change in supply voltage (ΔV_{CC}):

$$\text{PSRR} = \frac{\Delta I_i}{\Delta V_{\text{CC}}}$$

For example, a 4 mV disturbance on V_{CC} at 10 MHz will typically add an extra 120 nA to I_i (photodiode output current). The value of the external capacitor connected between pads DREF and GND has a significant effect on the value of PSRR. The specification is valid with an external capacitor of 1 nF.

SDH/SONET STM16/OC48
transimpedance amplifier

TZA3013A; TZA3013B

TYPICAL PERFORMANCE CHARACTERISTICS

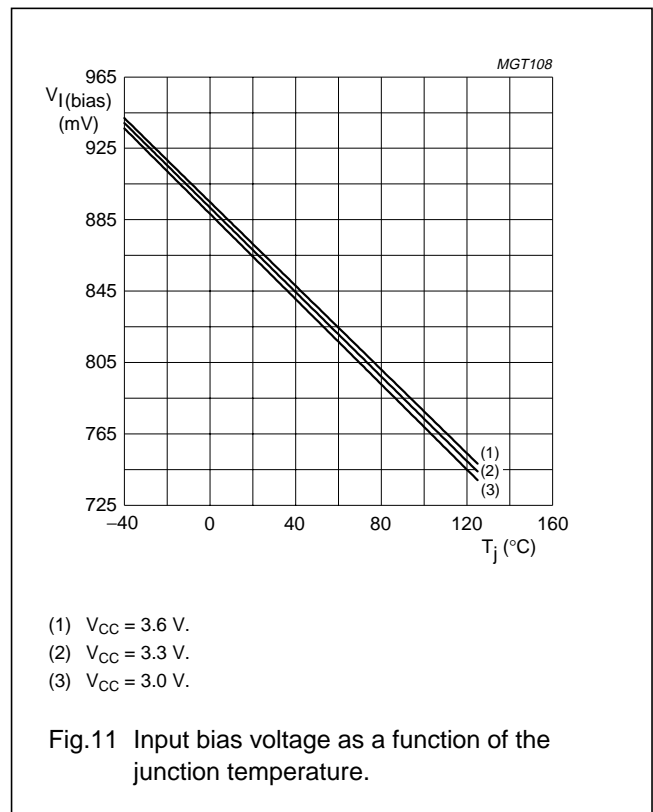
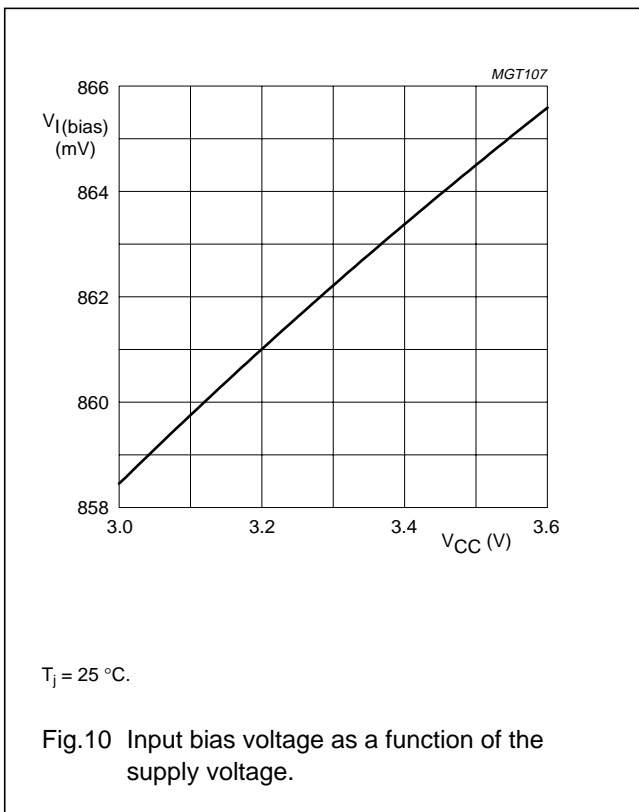
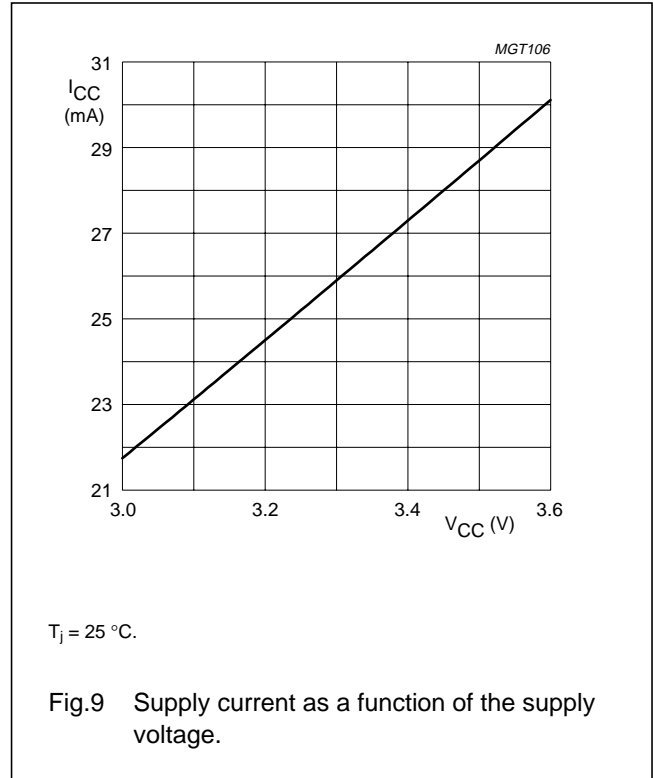
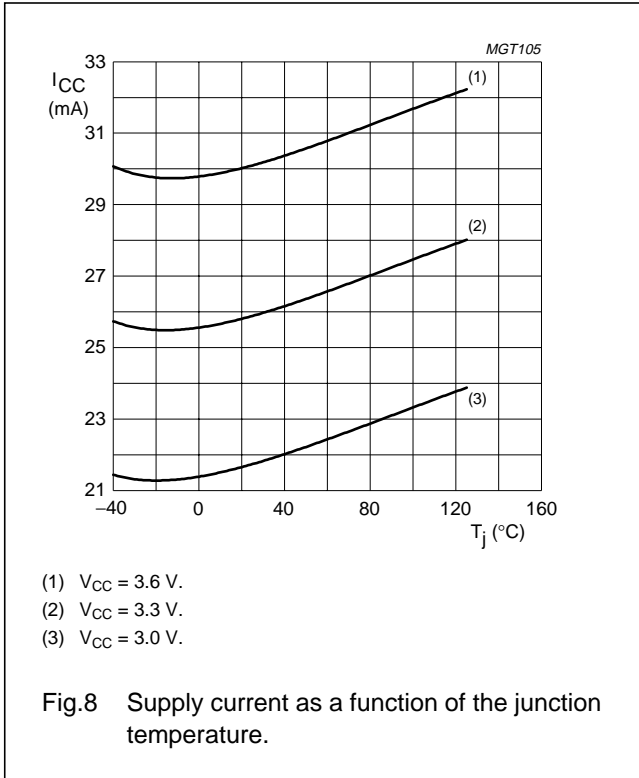

SDH/SONET STM16/OC48
transimpedance amplifier

TZA3013A; TZA3013B

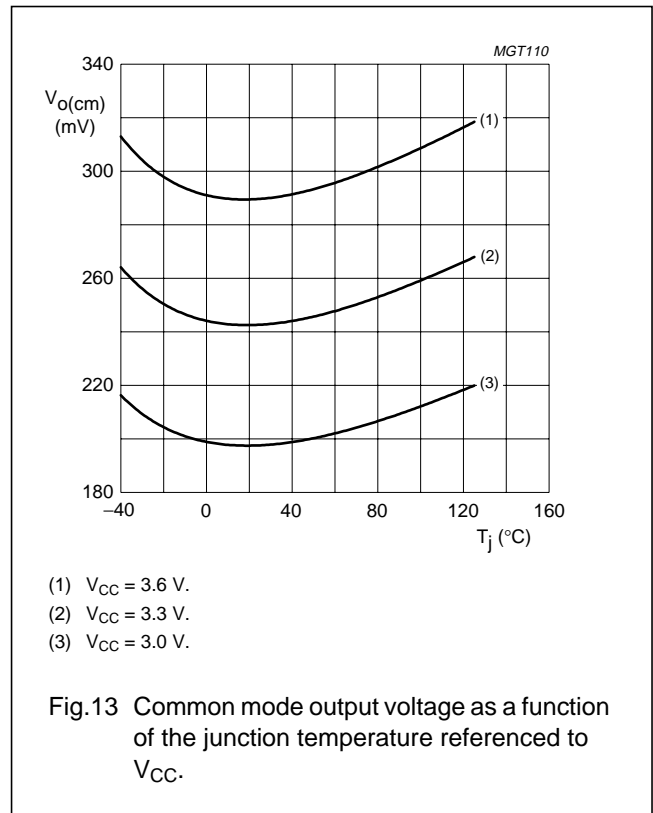
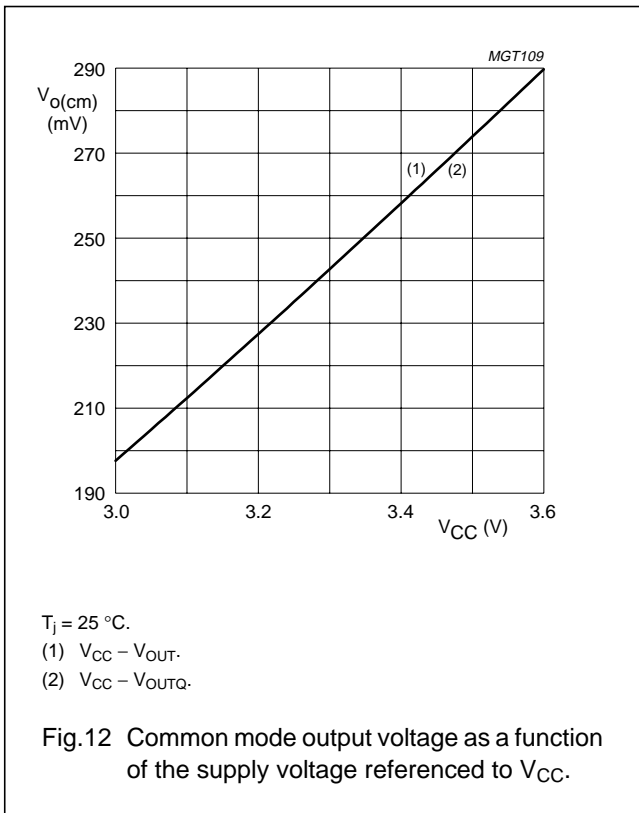

SDH/SONET STM16/OC48
transimpedance amplifier

TZA3013A; TZA3013B

APPLICATION AND TEST INFORMATION

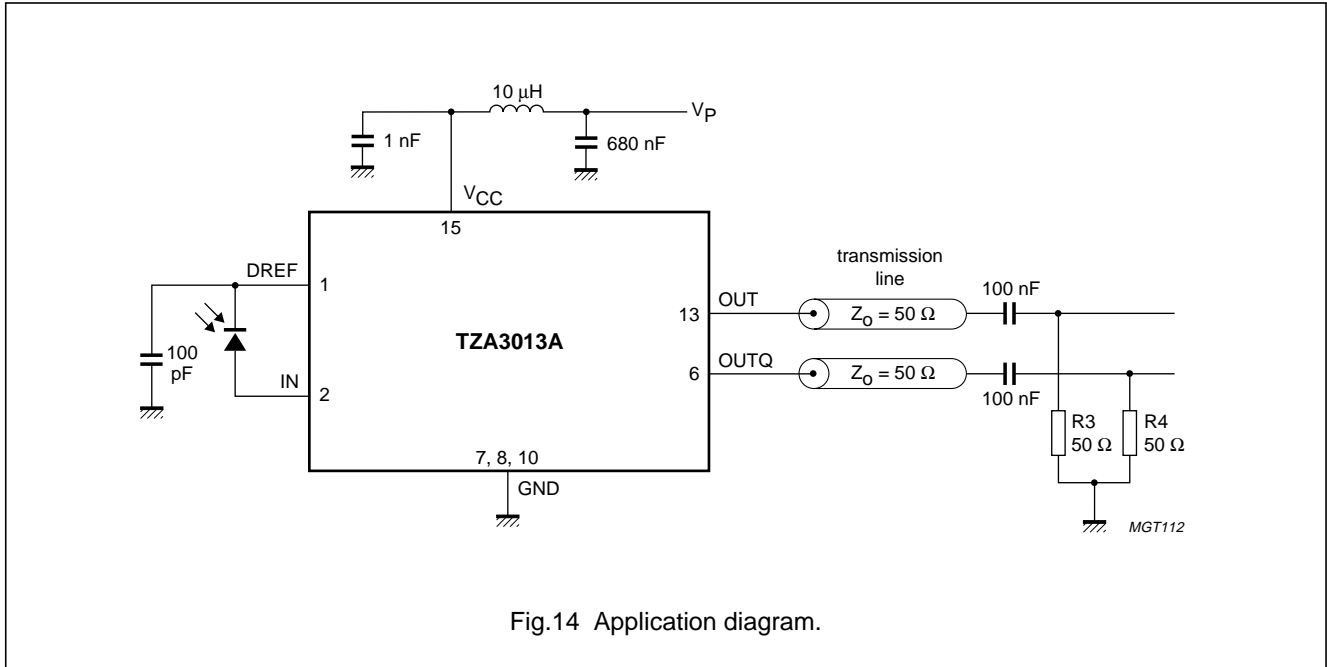

Fig.14 Application diagram.

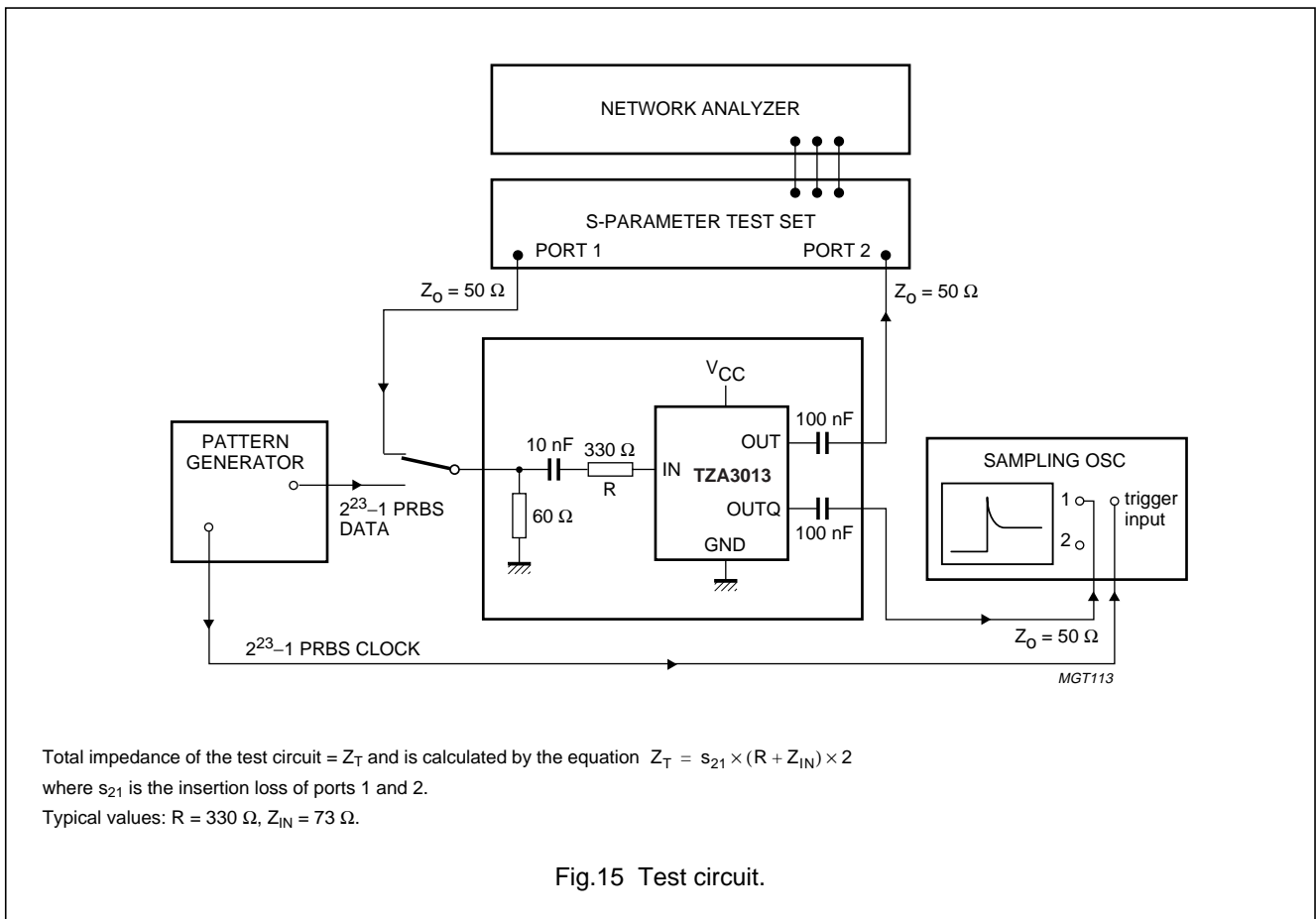

Fig.15 Test circuit.

SDH/SONET STM16/OC48 transimpedance amplifier

TZA3013A; TZA3013B

BONDING PAD LOCATIONS

SYMBOL	PAD TZA3013AU	PAD TZA3013BU	COORDINATES ⁽¹⁾	
			x	y
DREF	1	1	-440	+155
IN	2	2	-440	+10
INQ	3	3	-440	-157
AGC	4	4	-266	-255
OUTQSENSE	5	-	-40	-255
	-	14	-40	+255
OUTQ	6	-	+116	-255
	-	13	+110	+255
GND A	7	7	+256	-255
GND A	8	8	+398	-255
TEST C	9	9	+448	-79
GND D	10	10	+448	+70
TEST D	11	11	+410	+255
PILOT	12	12	+260	+255
OUT	13	-	+110	+255
	-	6	+116	-255
OUTSENSE	14	-	-40	+255
	-	5	-40	-255
V _{CC}	15	15	-266	+255

Note

- All coordinates are referenced, in μm , to the centre of the die.

SDH/SONET STM16/OC48
transimpedance amplifier

TZA3013A; TZA3013B

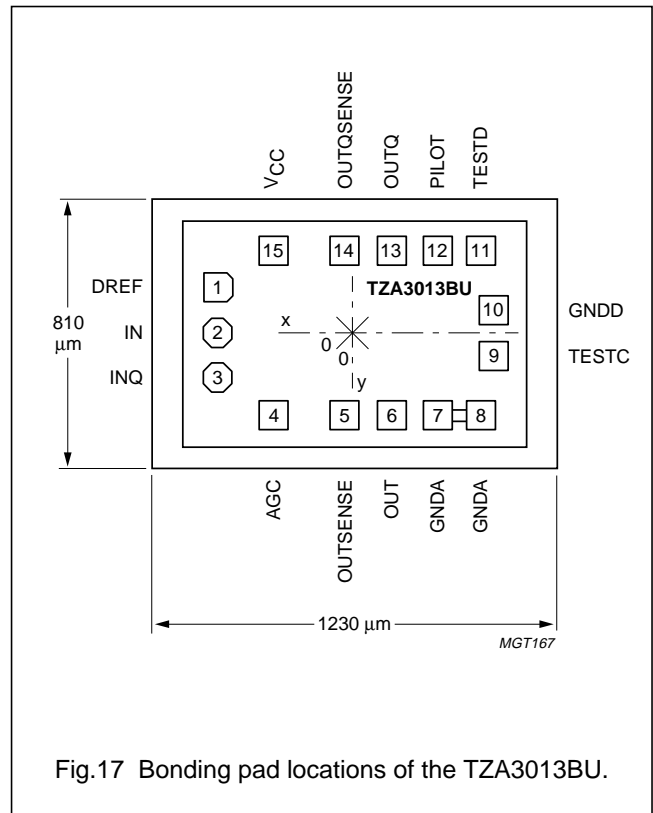
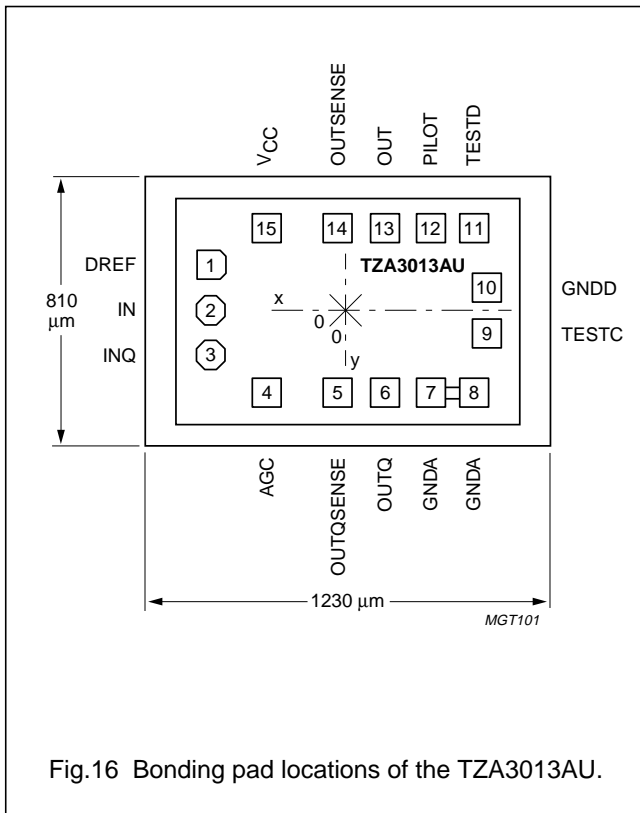

Physical characteristics of the bare die

PARAMETER	VALUE
Glass passivation	0.3 μm PSG (PhosphoSilicate Glass) on top of 0.8 μm silicon nitride
Bonding pad dimension	minimum dimension of exposed metallization is 90 × 90 μm (pad size = 100 × 100 μm) except pads 2 and 3 which have exposed metallization of 80 × 80 μm (pad size = 90 × 90 μm)
Metallization	2.8 μm AlCu
Thickness	380 μm nominal
Size	0.810 × 1.230 mm (0.996 mm ²)
Backing	silicon; electrically connected to GND potential through substrate contacts
Attach temperature	<440 °C; recommended die attach is glue
Attach time	<15 s

SDH/SONET STM16/OC48 transimpedance amplifier

TZA3013A; TZA3013B

DATA SHEET STATUS

DATA SHEET STATUS	PRODUCT STATUS	DEFINITIONS ⁽¹⁾
Objective specification	Development	This data sheet contains the design target or goal specifications for product development. Specification may change in any manner without notice.
Preliminary specification	Qualification	This data sheet contains preliminary data, and supplementary data will be published at a later date. Philips Semiconductors reserves the right to make changes at any time without notice in order to improve design and supply the best possible product.
Product specification	Production	This data sheet contains final specifications. Philips Semiconductors reserves the right to make changes at any time without notice in order to improve design and supply the best possible product.

Note

1. Please consult the most recently issued data sheet before initiating or completing a design.

DEFINITIONS

Short-form specification — The data in a short-form specification is extracted from a full data sheet with the same type number and title. For detailed information see the relevant data sheet or data handbook.

Limiting values definition — Limiting values given are in accordance with the Absolute Maximum Rating System (IEC 60134). Stress above one or more of the limiting values may cause permanent damage to the device. These are stress ratings only and operation of the device at these or at any other conditions above those given in the Characteristics sections of the specification is not implied. Exposure to limiting values for extended periods may affect device reliability.

Application information — Applications that are described herein for any of these products are for illustrative purposes only. Philips Semiconductors make no representation or warranty that such applications will be suitable for the specified use without further testing or modification.

DISCLAIMERS

Life support applications — These products are not designed for use in life support appliances, devices, or systems where malfunction of these products can reasonably be expected to result in personal injury. Philips Semiconductors customers using or selling these products for use in such applications do so at their own risk and agree to fully indemnify Philips Semiconductors for any damages resulting from such application.

Right to make changes — Philips Semiconductors reserves the right to make changes, without notice, in the products, including circuits, standard cells, and/or software, described or contained herein in order to improve design and/or performance. Philips Semiconductors assumes no responsibility or liability for the use of any of these products, conveys no licence or title under any patent, copyright, or mask work right to these products, and makes no representations or warranties that these products are free from patent, copyright, or mask work right infringement, unless otherwise specified.

BARE DIE DISCLAIMER

All die are tested and are guaranteed to comply with all data sheet limits up to the point of wafer sawing for a period of ninety (90) days from the date of Philips' delivery. If there are data sheet limits not guaranteed, these will be separately indicated in the data sheet. There is no post wafer pack testing performed on individual die. Although the most modern processes are utilized for wafer sawing and die pick and place into wafer pack carriers, Philips Semiconductors has no control of third party procedures in the handling, packing or assembly of the die. Accordingly, Philips Semiconductors assumes no liability for device functionality or performance of the die or systems after handling, packing or assembly of the die. It is the responsibility of the customer to test and qualify their application in which the die is used.

Philips Semiconductors – a worldwide company

Argentina: see South America

Australia: 3 Figtree Drive, HOMEBUSH, NSW 2140,
Tel. +61 2 9704 8141, Fax. +61 2 9704 8139

Austria: Computerstr. 6, A-1101 WIEN, P.O. Box 213,
Tel. +43 1 60 101 1248, Fax. +43 1 60 101 1210

Belarus: Hotel Minsk Business Center, Bld. 3, r. 1211, Volodarski Str. 6,
220050 MINSK, Tel. +375 172 20 0733, Fax. +375 172 20 0773

Belgium: see The Netherlands

Brazil: see South America

Bulgaria: Philips Bulgaria Ltd., Energoproject, 15th floor,
51 James Bourchier Blvd., 1407 SOFIA,
Tel. +359 2 68 9211, Fax. +359 2 68 9102

Canada: PHILIPS SEMICONDUCTORS/COMPONENTS,
Tel. +1 800 234 7381, Fax. +1 800 943 0087

China/Hong Kong: 501 Hong Kong Industrial Technology Centre,
72 Tat Chee Avenue, Kowloon Tong, HONG KONG,
Tel. +852 2319 7888, Fax. +852 2319 7700

Colombia: see South America

Czech Republic: see Austria

Denmark: Sydhavnsgade 23, 1780 COPENHAGEN V,
Tel. +45 33 29 3333, Fax. +45 33 29 3905

Finland: Sinikalliontie 3, FIN-02630 ESPOO,
Tel. +358 9 615 800, Fax. +358 9 6158 0920

France: 51 Rue Carnot, BP317, 92156 SURESNES Cedex,
Tel. +33 1 4099 6161, Fax. +33 1 4099 6427

Germany: Hammerbrookstraße 69, D-20097 HAMBURG,
Tel. +49 40 2353 60, Fax. +49 40 2353 6300

Hungary: Philips Hungary Ltd., H-1119 Budapest, Fehervari ut 84/A,
Tel: +36 1 382 1700, Fax: +36 1 382 1800

India: Philips INDIA Ltd, Band Box Building, 2nd floor,
254-D, Dr. Annie Besant Road, Worli, MUMBAI 400 025,
Tel. +91 22 493 8541, Fax. +91 22 493 0966

Indonesia: PT Philips Development Corporation, Semiconductors Division,
Gedung Philips, Jl. Buncit Raya Kav.99-100, JAKARTA 12510,
Tel. +62 21 794 0040 ext. 2501, Fax. +62 21 794 0080

Ireland: Newstead, Clonskeagh, DUBLIN 14,
Tel. +353 1 7640 000, Fax. +353 1 7640 200

Israel: RAPAC Electronics, 7 Kehilat Saloniki St, PO Box 18053,
TEL AVIV 61180, Tel. +972 3 645 0444, Fax. +972 3 649 1007

Italy: PHILIPS SEMICONDUCTORS, Via Casati, 23 - 20052 MONZA (MI),
Tel. +39 039 203 6838, Fax +39 039 203 6800

Japan: Philips Bldg 13-37, Kohnan 2-chome, Minato-ku,
TOKYO 108-8507, Tel. +81 3 3740 5130, Fax. +81 3 3740 5057

Korea: Philips House, 260-199 Itaewon-dong, Yongsan-ku, SEOUL,
Tel. +82 2 709 1412, Fax. +82 2 709 1415

Malaysia: No. 76 Jalan Universiti, 46200 PETALING JAYA, SELANGOR,
Tel. +60 3 750 5214, Fax. +60 3 757 4880

Mexico: 5900 Gateway East, Suite 200, EL PASO, TEXAS 79905,
Tel. +9-5 800 234 7381, Fax +9-5 800 943 0087

Middle East: see Italy

Netherlands: Postbus 90050, 5600 PB EINDHOVEN, Bldg. VB,
Tel. +31 40 27 82785, Fax. +31 40 27 88399

New Zealand: 2 Wagener Place, C.P.O. Box 1041, AUCKLAND,
Tel. +64 9 849 4160, Fax. +64 9 849 7811

Norway: Box 1, Manglerud 0612, OSLO,
Tel. +47 22 74 8000, Fax. +47 22 74 8341

Pakistan: see Singapore

Philippines: Philips Semiconductors Philippines Inc.,
106 Valero St. Salcedo Village, P.O. Box 2108 MCC, MAKATI,
Metro MANILA, Tel. +63 2 816 6380, Fax. +63 2 817 3474

Poland: Al.Jerozolimskie 195 B, 02-222 WARSAW,
Tel. +48 22 5710 000, Fax. +48 22 5710 001

Portugal: see Spain

Romania: see Italy

Russia: Philips Russia, Ul. Usatcheva 35A, 119048 MOSCOW,
Tel. +7 095 755 6918, Fax. +7 095 755 6919

Singapore: Lorong 1, Toa Payoh, SINGAPORE 319762,
Tel. +65 350 2538, Fax. +65 251 6500

Slovakia: see Austria

Slovenia: see Italy

South Africa: S.A. PHILIPS Pty Ltd., 195-215 Main Road Martindale,
2092 JOHANNESBURG, P.O. Box 58088 Newville 2114,
Tel. +27 11 471 5401, Fax. +27 11 471 5398

South America: Al. Vicente Pinzon, 173, 6th floor,
04547-130 SÃO PAULO, SP, Brazil,
Tel. +55 11 821 2333, Fax. +55 11 821 2382

Spain: Balmes 22, 08007 BARCELONA,
Tel. +34 93 301 6312, Fax. +34 93 301 4107

Sweden: Kottbygatan 7, Akalla, S-16485 STOCKHOLM,
Tel. +46 8 5985 2000, Fax. +46 8 5985 2745

Switzerland: Allmendstrasse 140, CH-8027 ZÜRICH,
Tel. +41 1 488 2741 Fax. +41 1 488 3263

Taiwan: Philips Semiconductors, 5F, No. 96, Chien Kuo N. Rd., Sec. 1,
TAIPEI, Taiwan Tel. +886 2 2134 2451, Fax. +886 2 2134 2874

Thailand: PHILIPS ELECTRONICS (THAILAND) Ltd.,
60/14 MOO 11, Bangna Trad Road KM. 3, Bagna, BANGKOK 10260,
Tel. +66 2 361 7910, Fax. +66 2 398 3447

Turkey: Yukari Dudullu, Org. San. Blg., 2.Cad. Nr. 28 81260 Umraniye,
ISTANBUL, Tel. +90 216 522 1500, Fax. +90 216 522 1813

Ukraine: PHILIPS UKRAINE, 4 Patrice Lumumba str., Building B, Floor 7,
252042 KIEV, Tel. +380 44 264 2776, Fax. +380 44 268 0461

United Kingdom: Philips Semiconductors Ltd., 276 Bath Road, Hayes,
MIDDLESEX UB3 5BX, Tel. +44 208 730 5000, Fax. +44 208 754 8421

United States: 811 East Arques Avenue, SUNNYVALE, CA 94088-3409,
Tel. +1 800 234 7381, Fax. +1 800 943 0087

Uruguay: see South America

Vietnam: see Singapore

Yugoslavia: PHILIPS, Trg N. Pasica 5/v, 11000 BEOGRAD,
Tel. +381 11 3341 299, Fax.+381 11 3342 553

For all other countries apply to: Philips Semiconductors,
Marketing Communications, Building BE-p, P.O. Box 218, 5600 MD EINDHOVEN,
The Netherlands, Fax. +31 40 27 24825

Internet: <http://www.semiconductors.philips.com>

© Philips Electronics N.V. 2001

SCA 71

All rights are reserved. Reproduction in whole or in part is prohibited without the prior written consent of the copyright owner.

The information presented in this document does not form part of any quotation or contract, is believed to be accurate and reliable and may be changed without notice. No liability will be accepted by the publisher for any consequence of its use. Publication thereof does not convey nor imply any license under patent- or other industrial or intellectual property rights.

Printed in The Netherlands

403510/300/02/pp16

Date of release: 2001 Feb 26

Document order number: 9397 750 08038

Let's make things better.

**Philips
Semiconductors**



PHILIPS