

NCP5890

Light Management IC Dedicated for LCD Backlighting and Multi-LED Fun Light Applications

The NCP5890 is part of the Light Management IC (LMIC) family. It is a fully programmable subsystem that manages multiple illumination functions integrated into the silicon.

Features

- 34 V Output Voltage Capability
- Include Three Independent PWM to Control LED Segments
- 2.7 to 5.5 V Input Voltage Range
- 90% Peak Efficiency with 4.7 μ H / 150 m Ω Inductor
- Gradual Dimming Built-in
- Integrated Ambient Light Sensing Adjusts Backlight Contrast
- Built-in I2C Address Extension
- Tight 1% I-LED Tolerance
- True Cut Off Function Minimizes Load Leakage Current in Shutdown
- Ultra Thin 0.5 mm QFN16 Package
- This is a Pb-Free Device

Typical Applications

- Portable Back Light & Keyboard
- Digital Cellular Phone Camera Photo Flash

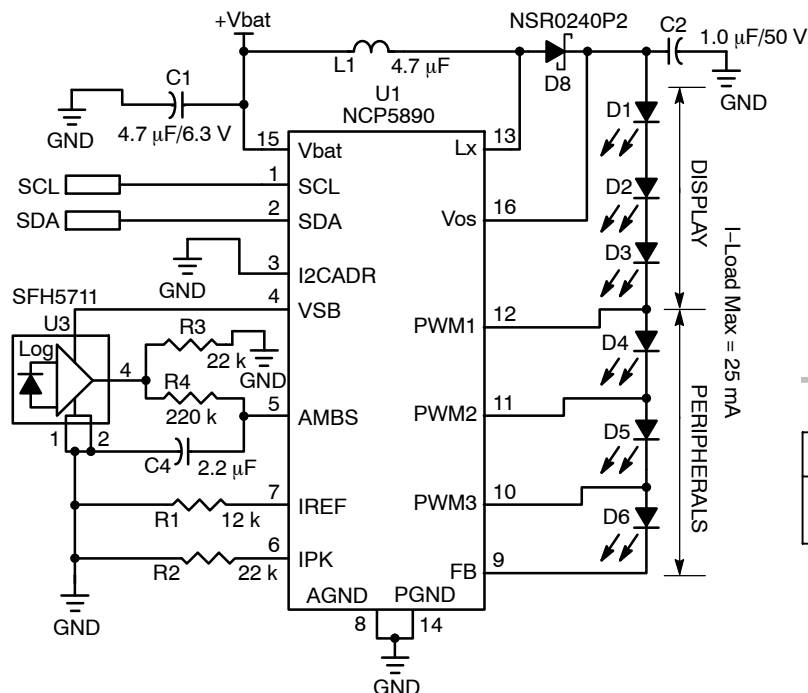
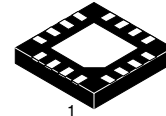

Figure 1. Typical Multiple White LED Application



ON Semiconductor®

<http://onsemi.com>



UQFN16
MU SUFFIX
CASE 523AF

MARKING DIAGRAM

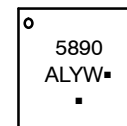

5890 = Specific Device Code
A = Assembly Location
L = Wafer Lot
Y = Year
W = Work Week
▪ = Pb-Free Package

(Note: Microdot may be in either location)

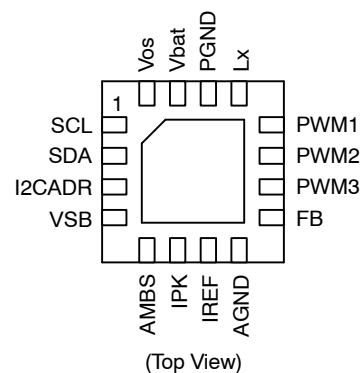

ORDERING INFORMATION

Device	Package	Shipping†
NCP5890MUTXG	UQFN16 (Pb-Free)	3000 / Tape & Reel

†For information on tape and reel specifications, including part orientation and tape sizes, please refer to our Tape and Reel Packaging Specification Brochure, BRD8011/D.

NCP5890

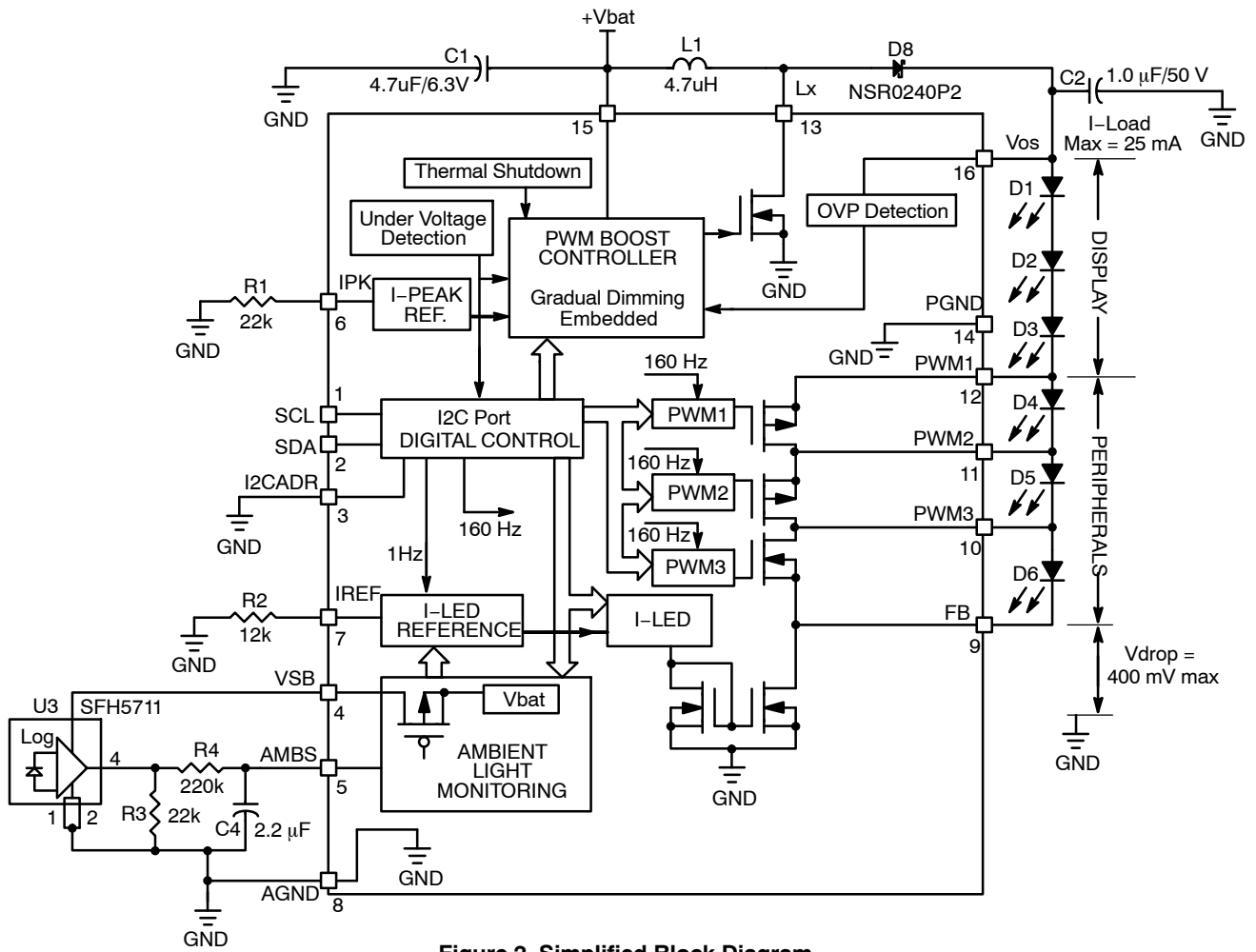

Figure 2. Simplified Block Diagram

NCP5890

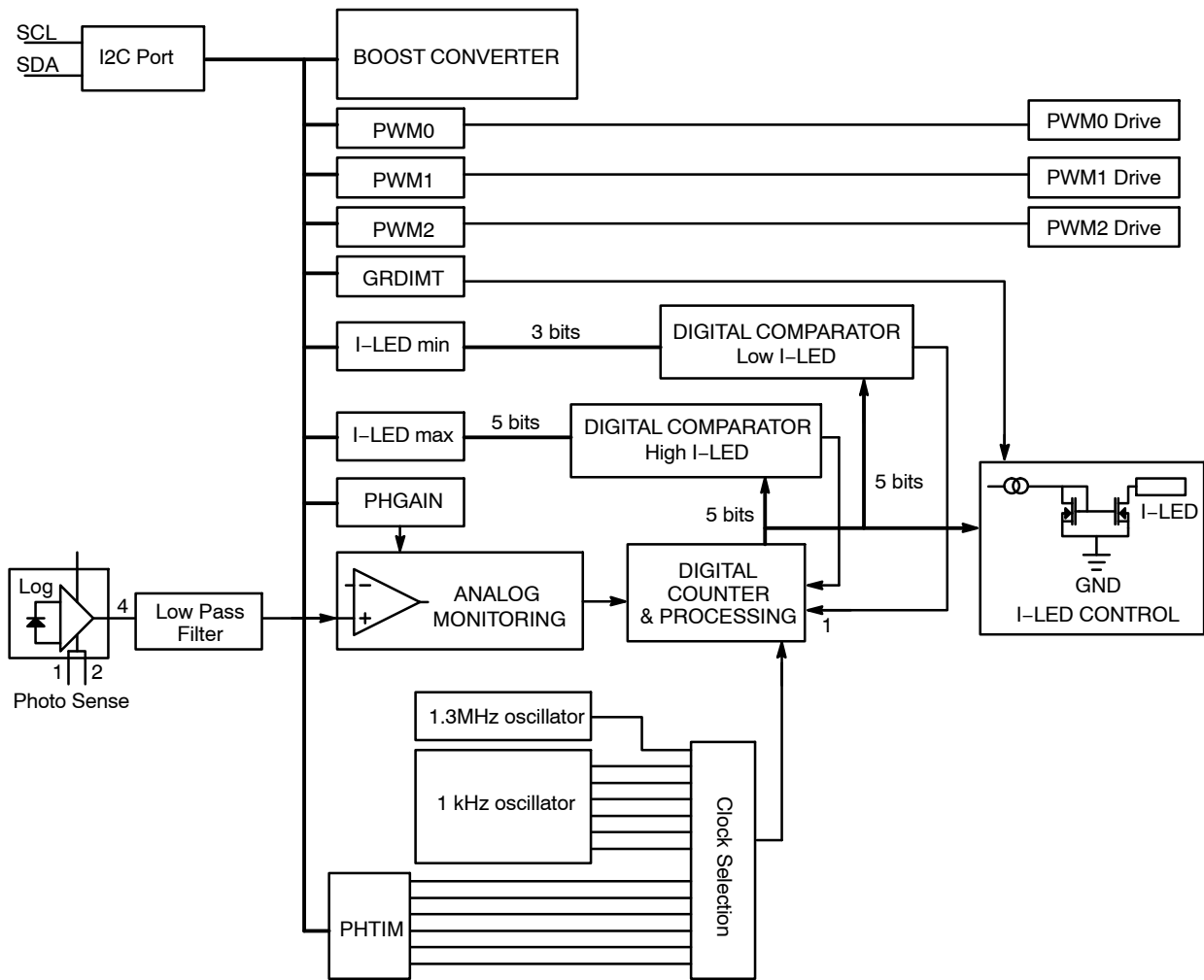

Figure 3. Basic NCP5890 Structure

NCP5890

PIN DESCRIPTIONS

PIN	Name	Type	Description
1	SCL	INPUT, DIGITAL	This pin carries the I2C clock to control the DC/DC converter and is used to set up the output current and the photo sensor. The SCL clock is associated with the SDA signal.
2	SDA	INPUT, DIGITAL	This pin carries the data provided by the I2C protocol. The content of the SDA byte is used to program the mode of operation and to set up the output current.
3	I2CADR	INPUT, DIGITAL	This pin is used to select the I2C address of the NCP5890: I2CADR = Low → address = %0111 0010 = \$72 I2CADR = High → address = %0111 0100 = \$74 In order to avoid any risk during the operation, the digital levels are intended to be hardwired prior to power up the system.
4	VSB	POWER, OUTPUT	This pin provides a switched voltage, derived from the Vbat supply, to bias the external photo sense. The current capability of this voltage is 2 mA. The VSB pin is disconnected when the Shutdown mode has been engaged.
5	AMBS	INPUT, ANALOG	This pin senses the voltage developed across the external Photo Bias resistor. Since this is a very high impedance input, care must be observed to minimize the leakage current and the noise that may influence the photo sense analog function. The bias parameters associated with the AMBS pin are reloaded when the chip resumes from Shutdown to Normal operation.
6	I _{PK}	INPUT, ANALOG	This pin provides the inductor peak current during normal operation. In no case shall the voltage at I _{PK} pin be forced either higher or lower than the 1144 mV provided by the internal reference.
7	I _{REF}	INPUT, ANALOG	This pin provides the reference current, based on the internal band-gap voltage reference, to control the output current flowing in the LED. A 1% tolerance, or better, resistor shall be used to get the highest accuracy of the LED biases. An external current source can be used to bias this pin to dim the light coming out of the LED. In no case shall the voltage at I _{REF} pin be forced either higher or lower than the 1144 mV provided by the internal reference.
8	AGND	POWER	This pin is the GROUND signal for the analog and digital blocks and must be connected to the system ground. A ground plane is strongly recommended.
9	FB	INPUT, ANALOG	This pin is the current sense of the series arranged LED. The built-in current mirror will automatically adapt the voltage drop across this pin (typically 400 mV).
10	PWM3	INPUT, ANALOG	This pin provides a PWM control of the LED connected between PWM3-FB. The PWM is programmed by the I2C port and preset to zero upon power ON.
11	PWM2	INPUT, ANALOG	This pin provides a PWM control of the LED connected between PWM2. The PWM is programmed by the I2C port and preset to zero upon power ON.
12	PWM1	INPUT, ANALOG	This pin provides a PWM control of the LED connected between PWM1. The PWM is programmed by the I2C port and preset to zero upon power ON.
13	Lx	POWER	The external inductor shall be connected between this pin (drain of the internal Power switch) and Vbat. The voltage is internally clamped at 34 V under worst case conditions. The external Schottky diode shall be connected as close as possible to this pin. See Note 1 for ESR recommendations.
14	PGND	POWER	This pin is the GROUND reference for the DC/DC converter and the output current control. The pin must be connected to the system ground, a ground plane is strongly recommended.
15	VBAT	INPUT, POWER	Input Battery voltage to supply the analog, the digital blocks and the main Power switch driver. The pin must be decoupled to ground by a 10 μF ceramic capacitor.
16	Vos	OUTPUT, POWER	This pin senses the output voltage supplied by the DC/DC converter. The Vos pin must be bypassed by 1.0 μF/50 V ceramic capacitor located as close as possible to the pin to properly bypass the output voltage to ground. The circuit will not operate without such bypass capacitor connected to the Vos pin. The output voltage is internally clamped to 34 V maximum in the event of a no load situation.

1. Using low ESR ceramic capacitor and low ESR inductor is mandatory to optimize the DC/DC efficiency

NCP5890

MAXIMUM RATINGS (Note 2)

Symbol	Rating	Value	Unit
V _{BAT}	Power Supply	-0.3 < V < 7.0	V
V _{LX}	Output Switching Voltage	34	V
SCL, SDA	Digital Input Voltage Digital Input Current	-0.3 < V < V _{BAT} 1	V mA
ESD	Human Body Model: R = 1500 Ω, C = 100 pF (Note 3) Machine Model	2 200	kV V
P _D R _{θjc} R _{θja}	UQFN16 package – Power Dissipation @ T _A = +85°C (Note 4) – Thermal Resistance Junction to Case – Thermal Resistance Junction to Air	300 50 130	mW °C/W °C/W
T _A	Operating Ambient Temperature Range	-40 to +85	°C
T _J	Operating Junction Temperature Range	-40 to +125	°C
T _{Jmax}	Maximum Junction Temperature	+150	°C
T _{stg}	Storage Temperature Range	-65 to +150	°C
	Latch-up current maximum rating per JEDEC standard: JESD78.	±100	mA

- Maximum electrical ratings define the values beyond which permanent damage(s) may occur internally to the chip whatever the operating temperature may be.
- This device series contains ESD protection and exceeds the following tests:
Human Body Model (HBM) ±2.0 kV per JEDEC standard: JESD22-A114
Machine Model (MM) ±200 V per JEDEC standard: JESD22-A115
- The maximum package power dissipation limit must not be exceeded.
- Moisture Sensitivity Level (MSL): 1 per IPC/JEDEC standard: J-STD-020A.

POWER SUPPLY SECTION: (Typical values are referenced to T_a = +25°C, Min & Max values are referenced -40°C to +85°C ambient temperature, unless otherwise noted), operating conditions 2.85 V < V_{bat} < 5.5 V, unless otherwise noted.

Pin	Symbol	Rating	Min	Typ	Max	Unit
15	V _{bat}	Power Supply	2.7		5.5	V
15	V _{UVLO}	Power Supply Input Voltage (See Figure 21)	2.0		2.4	V
15	V _{UVLOHY}	Under Voltage Hysterisis, negative going slope	150		270	mV
13	I _{out}	Continuous load DC current, V _{out} pin @ 3.0 V < V _{bat} < 5.5 V, C _{out} = 1.0 μF	25			mA
13	I _{sw}	Output Leakage Current (Lx pin) @ I _{out} = 0, V _{out} = 35 V			200	nA
	V _{out}	Output Voltage Compliance (OVP)	30	32	34	V
	V _{outHY}	OVP Output Voltage Hysterisis	1.0		1.8	V
	T _{start}	DC/DC Start time (C _{out} = 1.0 μF) 3.0 V < V _{bat} = nominal < 5.5 V from last ACK bit to full load operation		600		μs
15	I _{stdb}	Stand By Current, V _{bat} = 3.6 V, I _{out} = 0 mA @SCL = SDA = H (no port activity)			1.0	μA
15	I _{op}	Operating Current, @ I _{out} = 0 mA, V _{bat} = 3.6 V		2.0		mA
13	I _{PK}	Maximum Inductor Peak Current @ R = 13 kΩ	-15%	855	+15%	mA
13	I _{TOL}	Output Current Tolerance @V _{bat} = 3.6V, I _{LED} = 10 mA -25°C < T _A < 85°C		±1		%
13	F _{pwr}	Boost Operating Frequency (0°C < T _A < 85°C)	1.13	1.3	1.46	MHz
	T _{SD}	Thermal Shut Down Protection		160		°C
	T _{SDH}	Thermal Shut Down Protection Hysterisis		30		°C
	EPWR	Efficiency @ V _{bat} = 3.6 V, ESR ≤ 150 mΩ Coilcraft = LPQ3310-472, C _{out} = 1.0 μF I-LED = 10 mA, Vf = 2.85 V I-LED = 25 mA, Vf = 3.4 V (Note 6)		75 80		% %
	R _{DS(on)}	Power Switch NMOS R _{DS(on)}		500		mΩ

- Note 1: using low ESR inductor with low eddy current losses is mandatory to get the high efficiency operation

NCP5890

ANALOG SECTION: (Typical values are referenced to $T_A = +25^\circ\text{C}$, Min & Max values are referenced -40°C to $+85^\circ\text{C}$ ambient temperature, unless otherwise noted), operating conditions $2.85\text{ V} < V_{\text{bat}} < 5.5\text{ V}$, unless otherwise noted.

Pin	Symbol	Rating	Min	Typ	Max	Unit
7	I_{REF}	Reference Current @ $V_{\text{ref}} = 1144\text{ mV}$ (Note 8)	1		100	μA
6	I_{PK}	Reference Current @ $V_{\text{ref}} = 1144\text{ mV}$ (Note 8)	1		100	μA
	k_{ref}	Reference Current to ILED peak current ratio		250		
	k_{pk}	Reference Current to Inductor peak current ratio		9700		
7	V_{REF}	Reference Voltage (Note 8)	-3%	1144	+3%	mV
6	V_{REFK}	Reference Voltage (Note 8)	-10%	1144	+10%	mV
9	V_{FB}	Feedback Voltage @ ILED = 25 mA (Note 9)		425		mV
	M_{DCY}	Boost Operating Maximum Duty Cycle ($0^\circ\text{C} < T_A < 85^\circ\text{C}$)	90	94		%
9	I_{LKGM}	Current Mirror Leakage Current			200	nA
10, 11, 12	F_{pwm}	Low Frequency PWM Clock (derived from $F_{\text{pwr}}/8192$)	140	160	185	Hz
	F_{LF}	Low Frequency Clock (derived from $F_{\text{pwr}}/8192$)	0.6		20	Hz
4	V_{VSD}	Photo sense bias supply @ $I_{\text{bias}} = 1\text{ mA}$	2.5		V_{bat}	V
4	R_{VSD}	Photo sense bias supply internal impedance		30		Ω
4	I_{SDUSD}	Photo sense leakage current (Note 11)			100	nA
	$G_{\text{AMB0.25}}$	Photo sense internal Gain 1/4		0.25		
	$G_{\text{AMB0.50}}$	Photo sense internal Gain 1/2		0.5		
	G_{AMB01}	Photo sense internal Gain 1		1		
	G_{AMB02}	Photo sense internal Gain 2		2		
	G_{AMB04}	Photo sense internal Gain 4		4		
5	V_{iph}	Photo sense input voltage (Note 10)			1.5	V
10	BV_{pwm2}	Breakdown Voltage pin 10 to pin 10 (Note 11)	9			V
11	BV_{pwm2}	Breakdown Voltage pin 11 to Pin 12 (Note 11)	9			V
12	BV_{pwm1}	Breakdown voltage pin 12 to GND (Note 11)	9			V

7. The overall output current tolerance depends upon the accuracy of the external resistor. Using 1% or better resistor is recommended.
8. The external circuit must not force the I_{REF} or I_{PK} pin voltage either higher or lower than the specified voltage. The reference voltage applies to both I_{REF} and I_{PK} pins.
9. This parameter guarantees the function for production test purposes.
10. The ambient sense linearity is guaranteed when the voltage at the output of the internal amplifier is limited to 1.5 V. This voltage is equal to the input voltage times the programmed gain. Beyond this value, the operational amplifier is in the saturation region and the linearity is no longer guaranteed.
11. Parameter guaranteed by design, not tested in production.

DIGITAL PARAMETERS SECTION: (Typical values are referenced to $T_a = +25^\circ\text{C}$, Min & Max values are referenced -40°C to $+85^\circ\text{C}$ ambient temperature, unless otherwise noted), operating conditions $2.85\text{ V} < V_{\text{bat}} < 5.5\text{ V}$, unless otherwise noted.

Pin	Symbol	Rating	Min	Typ	Max	Unit
1	F_{SCK}	Input I2C clock frequency			400	kHz
1,2	V_{IH}	Positive going Input High Voltage Threshold, SCL, SDA signals	1.6		V_{BAT}	V
1,2	V_{IL}	Negative going Input High Voltage Threshold, SCL, SDA signals	0		0.4	V
2	C_{IN}	SDA Input Capacitance		10	15	pF
3	V_{IH}	I2C address extension	$V_{\text{bat}}*0.7$		$V_{\text{bat}}+0.3\text{V}$	V
3	V_{IL}	I2C address extension	0		0.3	V

NOTE: Digital inputs undershoot $< -0.30\text{ V}$ to ground, Digital inputs overshoot $< 0.30\text{ V}$ to V_{BAT}

DC/DC OPERATION

The boost converter is based on a PWM structure to generate the output voltage necessary to drive the series arranged LED. The system includes an open load detection to avoid over voltage situation when the LED are disconnected from the Vout pin. A built-in circuit prevent high inrush current when the system is powered.

The ILED is regulated by means of a built-in current mirror controlled by the digital content of the ILEDREG register. With a typical 1.3 Mhz operation frequency, the converter can run at full power with a tiny 4.7 μH inductor. However, care must be observed, at ESR level, to optimize the total DC/DC conversion efficiency. In particular, the ferrite material shall have limited eddy current losses at high frequency. Depending upon the type of material, the eddy losses in the inductor can range from a low 40 mW to a high 250 mW under the same bias and load conditions.

The ILED current is regulated by the means of internal current mirror connected to the FB pin. The voltage at this pin can vary between a low 100 mV to a 1.5 V maximum, depending upon the ILED current amplitude. Typically, the FB voltage will be 425 mV under normal operation.

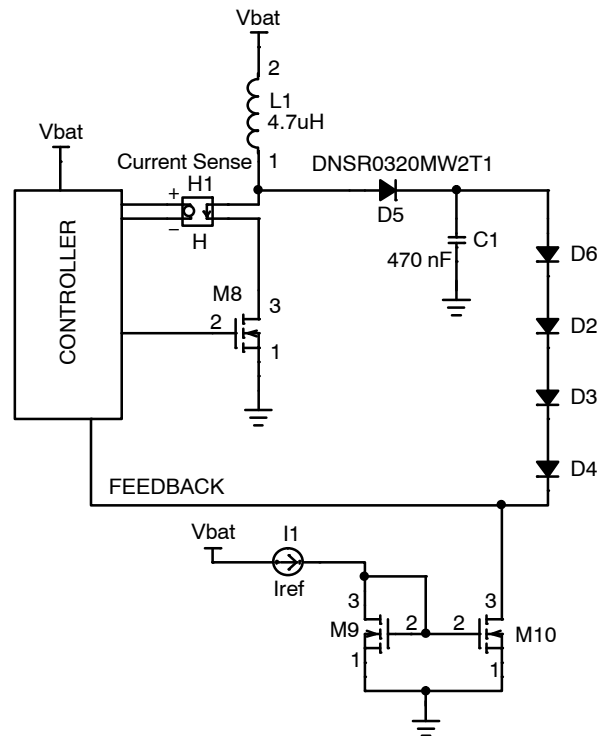

Figure 4. Simplified Boost Structure

Table 1. Recommended Inductor Manufacturers

Part Number	Manufacturers
LPQ3310-472	COILCRAFT
	TDK
	MURATA

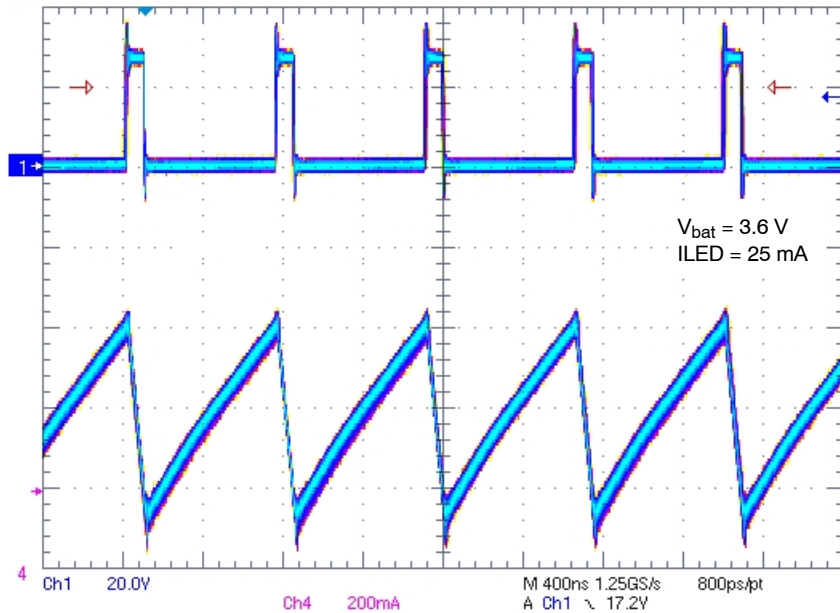

Figure 5. Typical Switching Operation

I2C Protocol

The standard I2C protocol is used to transfer the data from the MCU to the NCP5890. Leaving aside the Acknowledge bit, the NCP5890 chip does not return data back to the MCU.

The physical address of the NCP5890 can be selected as 0111 001X or 0111 010X (the X being the Read / Write identifier as defined by the I2C specification) depending upon the digital status present at the I2CADR pin:

NCP5890

I2CADR = Low → address = %0111 0010 = \$72

I2CADR = High → address = %0111 0100 = \$74

In order to avoid any risk during the operation, the digital level at the I2CADR pin must be hardwired either to GND or to Vbat prior to power up the system.

The first byte of the I2C frame shall be selected address (\$72 or \$74) when a Write is send to the chip.

To set up a new output current value, a full frame will be sent by the MCU. The frame contains three consecutive bytes and shall fulfill the I2C specifications (see Figure 6):

- First byte: I2C address, write → \$72 (assuming I2CADR = Low)
- Second byte: register selection → %0000 0000 = internal register address
- Third byte: DATA → %0000 0000 = function / output current value

An infinite number of register selection / data pair can be send on the I2C port once the physical address has been decoded (see Figure 7). The transmission ends when the STOP signal is send by the SCL/SDA digital code.

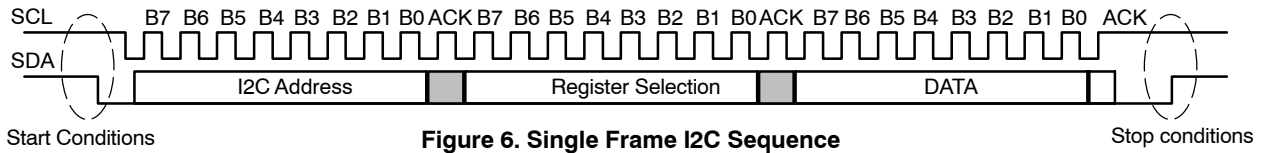

Figure 6. Single Frame I2C Sequence

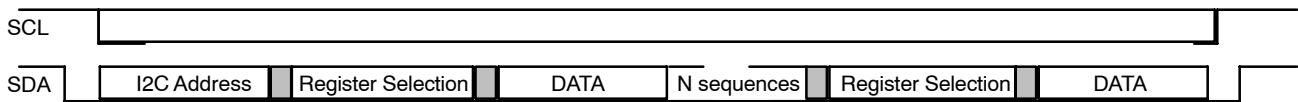

Figure 7. Multi Frames I2C Sequence

On the other hand, although the chip does not handle the Read operation, care must be observed since sending a Read command (\$73 or \$75) is equivalent to a Write command and the selected register will be updated accordingly.

Registers Setup Selection

The register selection follows the I2C address of a new frame and must be followed by the DATA register. The

content of the register selection byte is not stored into the chip and a new one must be sent for every DATA update. The low nibble contains the selected register number as depicted in Table 2. The high nibble is reserved for future use.

The last code \$0F is reserved for ON Semiconductor to control the manufacturing test and access to this register is not permitted outside the ON Semiconductor final test facilities.

Table 2. Register Selection Code

\$	B7	B6	B5	B4	B3	B2	B1	B0	
00	0	0	0	0	0	0	0	0	Shut Down the chip
01	0	0	0	0	0	0	0	1	Select I-LED current setup and immediate LED update
02	0	0	0	0	0	0	1	0	Set ILED target and Gradual Dimming UPWARD
03	0	0	0	0	0	0	1	1	Set ILED target and Gradual Dimming DOWNWD
04	0	0	0	0	0	1	0	0	Set timing and start the gradual dimming
05	0	0	0	0	0	1	0	1	Select PWM0 register
06	0	0	0	0	0	1	1	0	Select PWM1 register
07	0	0	0	0	0	1	1	1	Select PWM2 register
08	0	0	0	0	1	0	0	0	Set up Photo sense input stage gain
09	0	0	0	0	1	0	0	1	Set up Photo Sense I-LED minimum value
0A	0	0	0	0	1	0	1	0	Set up Photo Sense up/down timing
0B	0	0	0	0	1	0	1	1	RFU
0C	0	0	0	0	1	1	0	0	RFU
0D	0	0	0	0	1	1	0	1	RFU
0E	0	0	0	0	1	1	1	0	RFU
0F	0	0	0	0	1	1	1	1	Reserved for manufacturing test: <i>do not access</i>

Table 3. Registers Identification

DEC	Register functions	Register Identification	Command
1	Shut Down the chip	SDN	\$00
2	Select I-LED current setup and immediate LED update	ILEDREG[4..0]	\$01
3	Select I-LED target Gradual Dimming command UP	GDIM[4..0]	\$02
4	Select I-LED target Gradual Dimming command DOWN	GDIM[4..0]	\$03
5	Set Timing & Start gradual Dimming Sequence	TDIM[4..0]	\$04
6	Select PWM0 register	PWM0[4..0]	\$05
7	Select PWM1 register	PWM1[4..0]	\$06
8	Select PWM2 register	PWM2[4..0]	\$07
9	Set up Photo sense input stage gain	PHGAIN[4..0]	\$08
10	Set up Photo Sense I-LED minimum value	PHMIN[3..0]	\$09
11	Set up Photo Sense timing	PHCLK[5..0]	\$0A
12	RFU		\$0B
13	RFU		\$0C
14	RFU		\$0D
15	RFU		\$0E
16	Reserved for manufacturing test: <i>do not access</i>	FTEST[7..0]	\$0F

ILED Peak Current

The ILED peak current depends upon the reference current (I_{REF} pin) and the digital contents of the ILEDREG register. The I2C port is used to setup the ILED peak current stored into the ILEDREG register. The load current is derived from the 1144 mV reference voltage provided by the internal Band Gap associated to the external resistor connected across I_{REF} pin and Ground (see Figure 8). The maximum ILED current is given by the internal current mirror ratio (multiplier – k-) equal to 250. In other words,

to get a 25 mA maximum, with a full \$1F command, the reference current should be $25\text{ mA}/250 = 100\ \mu\text{A}$. This current is used to calculate the resistor connected between the I_{REF} pin and GND: $R_{REF} = 1.144 / 100\text{e-}6 = 11.44\ \text{k}\Omega$. In any case, no voltage shall be forced at I_{REF} pin, either downward or upward.

The tolerance of the external resistor must be 1% or better, with a 100 ppm thermal coefficient, to get the expected overall tolerance.

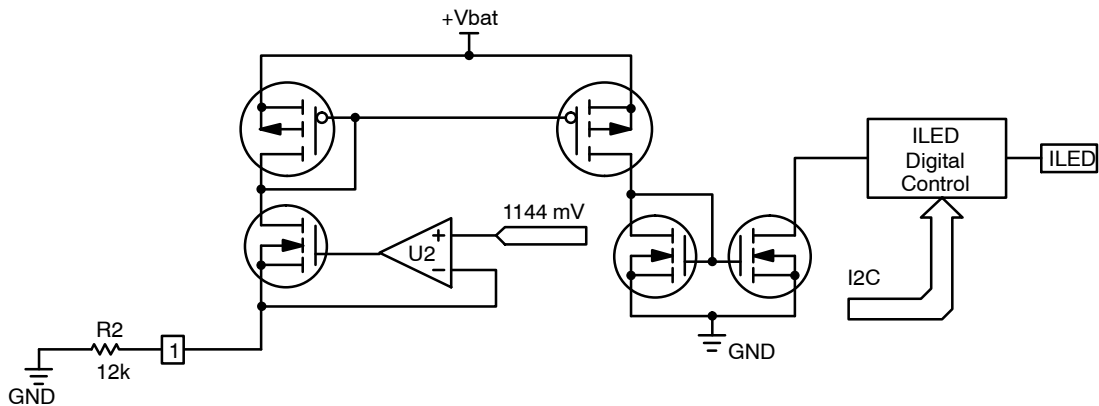

Figure 8. Basic Reference Current Source

NOTE: The I_{REF} pin must never be biased by an external voltage higher than 1144 mV.

NCP5890

The ILED current is given by Table 4 as a percentage of the maximum programmed ILED value (100% will give 25 mA when $I_{ref} = 100 \mu A$).

Table 4. Output Current Programmed Value ($I_{out} \% = F(\text{Step})$)

\$Step	Iout %	\$Step	Iout %	\$Step	Iout %	\$Step	Iout %
00	0.00	08	1.40	10	6.24	18	27.48
01	0.42	09	1.70	11	7.52	19	33.03
02	0.49	0A	2.00	12	9.11	1A	39.72
03	0.57	0B	2.42	13	10.92	1B	47.72
04	0.72	0C	2.99	14	13.08	1C	57.47
05	0.87	0D	3.63	15	15.80	1D	69.18
06	1.02	0E	4.35	16	18.97	1E	83.20
07	1.17	0F	5.22	17	22.86	1F	100.00

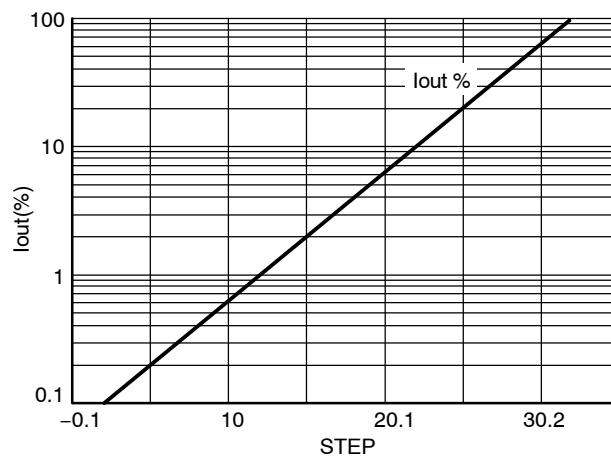

Figure 9. Typical ILED Programming Curve

ILEDREG[0..7] I-LED Peak Current

	B7	B6	B5	B4	B3	B2	B1	B0
step	0	0	0	ILED16	ILED8	ILED4	ILED2	ILED1
RESET	0	0	0	0	0	0	0	0

Bits [B7:B5] : RFU

Bits [B4:B0] : ILED peak current setup

Inductor Peak Current

The peak current flowing into the inductor during normal application is set up by the external resistor R_{PCA} connected between the I_{PK} pin and ground.

The maximum I_{PK} current is given by the internal current mirror ratio (multiplier – kk –) typically equal to 9700. In other words, to get a 750 mA maximum peak current in the inductor, the reference current should be 750 mA/9700 = 79 µA. This current is used to calculate the resistor connected between the I_{PK} pin and GND: R_{REF} = 1.144 / 79e-6 = 14.4 kΩ.

The concept depicted in the ILED peak current paragraph applies as well and care must be observed to avoid any voltage source connection to the IPK pin.

Gradual Dimming

The purpose of this function is to gradually Increase or Decrease the brightness of the backlight / keyboard LED upon command from the external MCU. The function is activated and controlled by means of the I2C protocol.

The period (either upward or downward) is equal to the time defined for each step, multiplied by the number of steps. The number of step is derived from the value associated with the target current.

To operate such a function, the MCU will provide three information:

1. The target current level (either upward or downward)
2. The time per step
3. The Upward or Downward mode of operation

When a new gradual dimming sequence is requested, the output current increases, according to the logarithmic curve, from the existing start value to the end value. The end current value is defined by the contents of the Upward or Downward register, the width of each step is defined by the third register, the number of steps being in the 1 to 32 range (\$00 to \$1F). In the event of a software error, the system checks that neither the maximum output current (25 mA), nor the zero level are forced out of their respective bounds. Similarly, software errors shall not force NCP5890 into an uncontrolled mode of operation.

The dimming is built with 32 steps and the time delay encoded into the third byte of the I2C transaction.

When the gradual dimming is not requested (register selection = \$01), the output current is set up to the level defined by the contents of the related register upon acknowledge of the output current byte.

The gradual dimming sequence must be set up before a new output current data byte is sent to the NCP5890. At this point, the brightness sequence takes place when the new data byte is acknowledged by the internal I2C decoder. Since the six registers are loaded on independent byte flow associated to the I2C address, any parameter of the NCP5890 chip can be updated ahead of the next function.

GDIMR[7..0] Gradual Dimming Target

	B7	B6	B5	B4	B3	B2	B1	B0
ms	0	0	0	ILED5	ILED4	ILED3	ILED2	ILED1
RESET	0	0	0	0	0	0	0	0

Bits [B7:B5] : RFU

Bits [B4:B0] : ILED peak current setup or Gradual Dimming Timing

The number of steps for a given sequence, depends upon the start and end output current range: since the IPEAK value is encoded in the ILEDREG [4:0] binary scale, a maximum of 31 steps is achievable during a gradual dimming operation.

To select the direction of the gradual dimming (either Upward or Downward), one shall set-up the appropriate register before to activate the sequence as depicted in the example here below:

- First Byte = 0111 0000 → I2C address (assuming I2CADDR = Low)

- Second byte = 0000 0010 → select an ILED target UPWARD sequence
- Third byte = 0000 1111 → set I-LED = 2.51% of the maximum range
- First Byte = 0111 0000 → I2C address (assuming I2CADDR = Low)
- Second byte = 0000 0100 → set Timing and start the sequence
- Third byte = 0000 0010 → set Timing per step = 20 ms/step

TDIM[7.0] Gradual Dimming Time per Step

	B7	B6	B5	B4	B3	B2	B1	B0
ms	0	0	0	200	100	50	25	12.5
RESET	0	0	0	0	0	0	0	0

Bits [B7:B5] : RFU

Bits [B4:B0] : Gradual Dimming Timing

NOTE: bit B0 = 2¹⁴/F, with F = operating frequency (1.3 MHz typical)

NCP5890

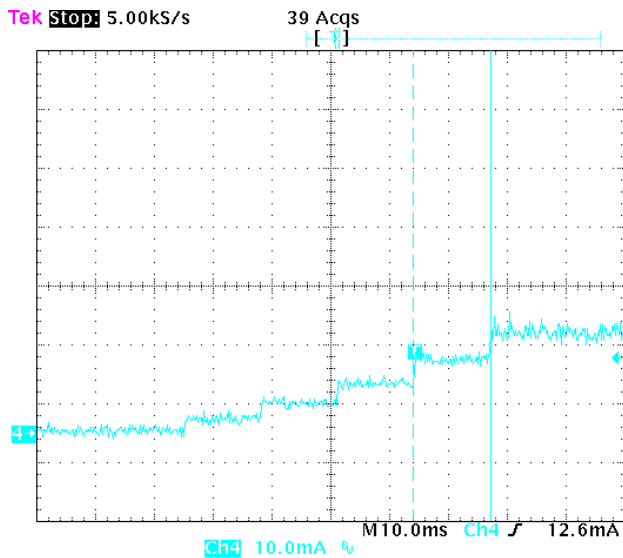

Figure 10. Typical Gradual Dimming UPWARD

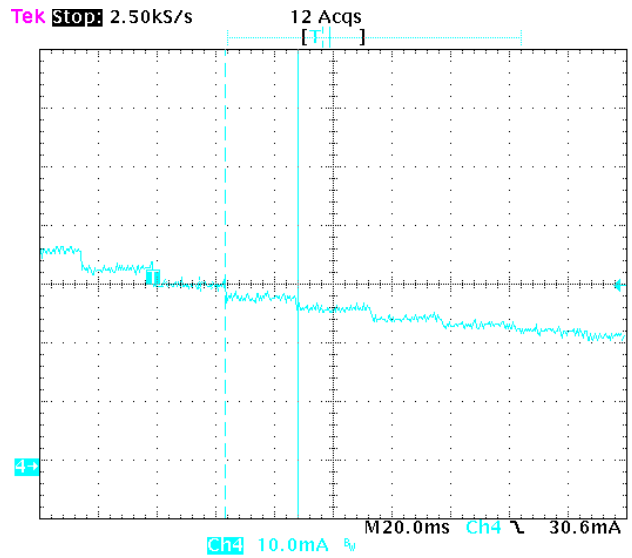

Figure 11. Typical Gradual Dimming DOWNWARD

Keyboard Dimming

The keyboard shares the same I-LED peak current with the backlight, but the built-in PWM structure makes possible a dynamic independent control of three sets of LED. Each PWM is associated with a register, the IC port being used to update the pulse modulation as requested by the application.

PWM0[7..0] PWM0 Modulation

	B7	B6	B5	B4	B3	B2	B1	B0
%	0	0	0	50	25	12.5	6.25	3.125
RESET	0	0	0	0	0	0	0	0

Bits [B7:B5] : RFU, Bits [B4:B0] : PWM0 setup

PWM1[7..0] : PWM1 Modulation

	B7	B6	B5	B4	B3	B2	B1	B0
%	0	0	0	50	25	12.5	6.25	3.125
RESET	0	0	0	0	0	0	0	0

Bits [B7:B5] : RFU, Bits [B4:B0] : PWM1 setup

PWM2[7..0] : PWM2 Modulation

	B7	B6	B5	B4	B3	B2	B1	B0
%	0	0	0	50	25	12.5	6.25	3.125
RESET	0	0	0	0	0	0	0	0

Bits [B7:B5] : RFU, Bits [B4:B0] : PWM2 setup

Backlight Dimming

The built-in I2C interface provides a simple way to accurately control the output peak current flowing in the LED. The internal register ILEDREG[7:0] is set up by the content of the SDA byte send by the external MCU. For typical application, the 100 μ A reference current forced by the external resistor yields a 25 mA maximum in the output LED. The waveforms given illustrate a normal programming sequence.

ILEDREG[0..7]

	B7	B6	B5	B4	B3	B2	B1	B0
step	0	0	0	ILED16	ILED8	ILED4	ILED2	ILED1
RESET	0	0	0	0	0	0	0	0

[B7:B6] = RFU

[B4..B0] = Output LED mA/step current. The content of these bits is latched to the current reference on the 8th SCL clock pulse.

Ambient Light Control

The ambient light can be monitored, by an extra photo diode, to automatically adjust the I-LED peak current as a function of the ambient light. A dedicated I2C command is used to activate or de-activate this function. On the other hand, the end user shall set up the maximum I-LED current by means of an I2C command. The photo sense is automatically de-activated when an I2C command is send through the port, and resume to the pre-programmed status when the I2C command is completed.

The concept is based on analog monitoring of the I-LED current and the photo sense feedback, associated to a Up/Down counter to properly setup the contrast at display level. The photo sense action is bounded by two limits:

- upper I-LED as defined by the end user: the photo sense cannot increase the I-LED above such a limit
- lower I-LED as defined by the end user: the photo sense cannot reduce the back light current to zero.

When the photo sense activates the counter (in either direction), a selectable low frequency clock drives the counter, yielding a smooth and slow brightness variation.

The 100 Hz noise, coming from standard fluorescent tubes, is filter out by means of an external network built between the photo sensor and the AMBS pin. Generally speaking, such a filter is built with a RC network designed to cope with the electrical performances of the selected photo sense. As a consequence, the AMBS pin is biased by a low level voltage signal and processed accordingly the ambient light control structure: see Figure 15.

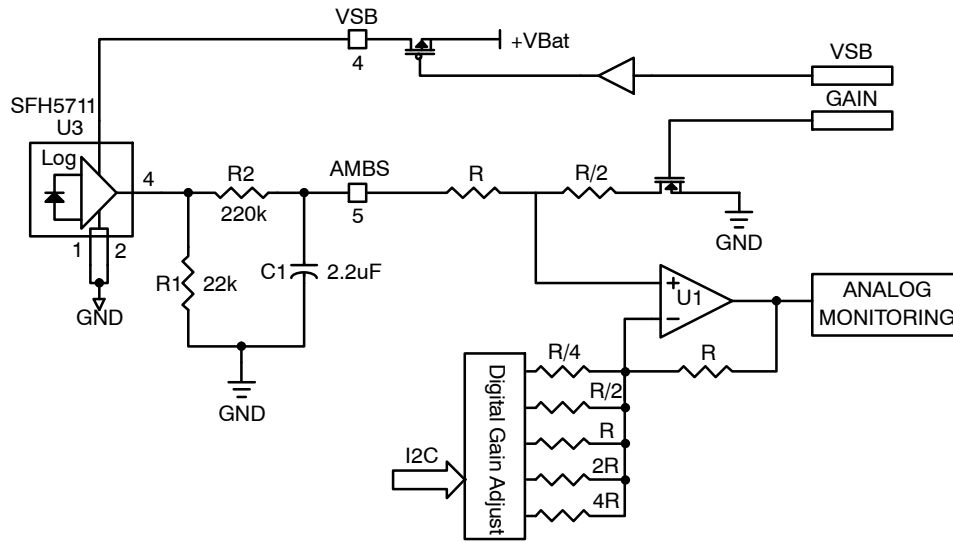

Figure 12. Basic Photo Sense Input Circuit

Since several types of photo sensor can be used in the final application, provisions have been taken into account to dynamically adjust the gain of the photo current. Such capability is carried out by the internal register loaded through the I2C port.

PHGAIN[0..7]

	B7	B6	B5	B4	B3	B2	B1	B0
	VSD	0	0	PHG5	PHG4	PHG3	PHG2	PHG1
RESET	0	0	0	0	0	0	0	0
Gain				4	2	1	0.50	0.25

Bit [B7] : Photo sense VSD bias control

B7 = 0 → VSD disconnected, photo sense function de-activated

B7 = 1 → VSD connected, photo sense function activated

Bits [B6:B5] : RFU

Bits [B4:B0] : Photo sensor gain adjust

The photo sensor no longer influences the I-LED when the gain is setup to \$00. On the other hand, the five bits can be digitally combined to get different gain in the range 0 to 7.5: example below

B7	B6	B5	B4	B3	B2	B1	B0	Gain
VSD	0	0	PHG5	PHG4	PHG3	PHG2	PHG1	
1	0	0	0	0	0	0	0	0
1	0	0	0	0	1	0	0.25	1.25
1	0	0	1	0	1	0	0	5

NCP5890

When the photo sense returns a lower ambient light level in comparison to the maximum level set up by the user, the I-LED decreases with a timing defined by an I2C

command. Such a timing is derived from the Low Frequency clock and selected by the PHTIM register (see Figure 13).

PHCLK[0..7]

	B7	B6	B5	B4	B3	B2	B1	B0
	0	0	PHT6	PHT5	PHT4	PHT3	PHT2	PHT1
RESET	0	0	0	0	0	0	0	0

Bits [B7] : RFU

Bits [B6] : RFU

Bits[B5:B0] :

PHT1 = Photo sense clock = 20 Hz → T = 50 ms/step

PHT2 = Photo sense clock = 10 Hz → T = 100 ms/step

PHT3 = Photo sense clock = 5 Hz → T = 200 ms/step

PHT4 = Photo sense clock = 2.5 Hz → T = 400 ms/step

PHT5 = Photo sense clock = 1.25 Hz → T = 800 ms/step

PHT6 = Photo sense clock = 0.6 MHz → T = 1600 ms/step

Bits [B7] : RFU

Note: the bits cannot be combined to generate a different timing.

In addition, the positive and negative slopes of the I-LED current are intentionally different. In order to generate a smooth transition of the backlight from maximum toward the minimum calculated by the photo sense, the timing of the negative going slope is twice the timing of the positive going slope.

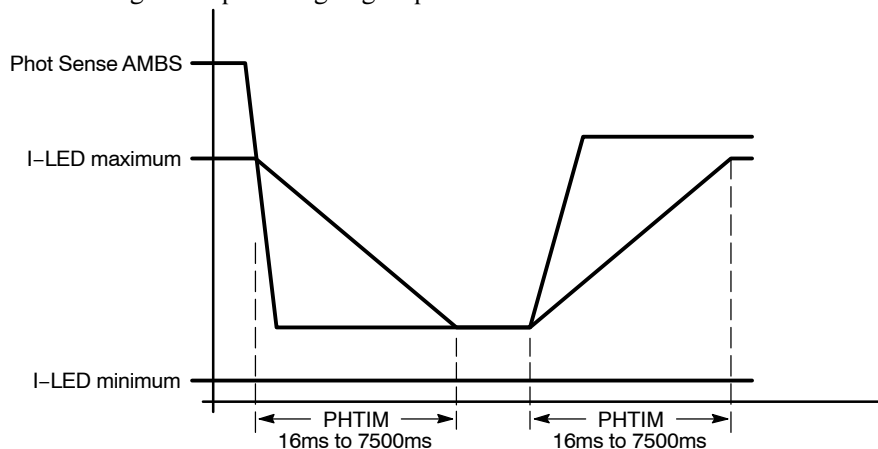

Figure 13. Basic Photo Sense Timing

The rise and fall time of the I-LED current are programmable (according to the PHTIM register contain). The timing is defined by the PHTIM[B4:B0] bits multiplied by the number of steps necessary to reduce / increase the I-LED from one value to the next limit.

On the other hand, the I-LED cannot reduce to zero during the Photo sense operation: the contain of the PHMIN[B2:B0] register limits the low end current when the photo sensor is in a dark environment.

PHMIM[0..7]

	B7	B6	B5	B4	B3	B2	B1	B0
	0	0	0	0	PHM4	PHM3	PHM2	PHM1
RESET	0	0	0	0	0	0	0	0

Bits [B7:B4] : RFU

Bits[B3:B0] : set up the I-LED minimum value, according to the logarithmic table.

NCP5890

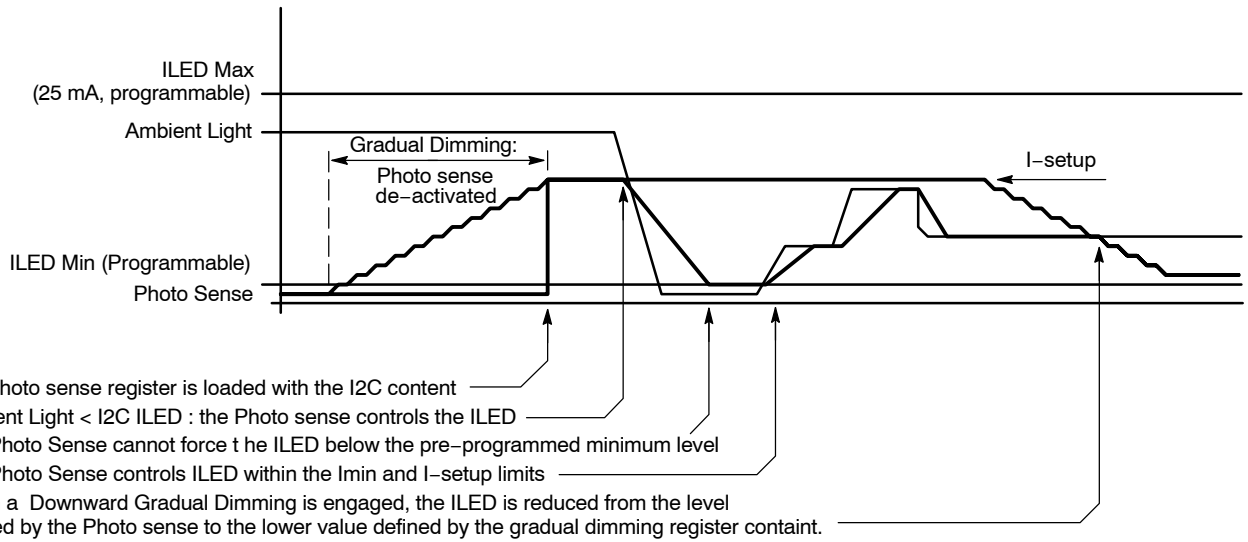

Figure 14. Basic Gradual Dimming and Photo Sense Operation Strategy

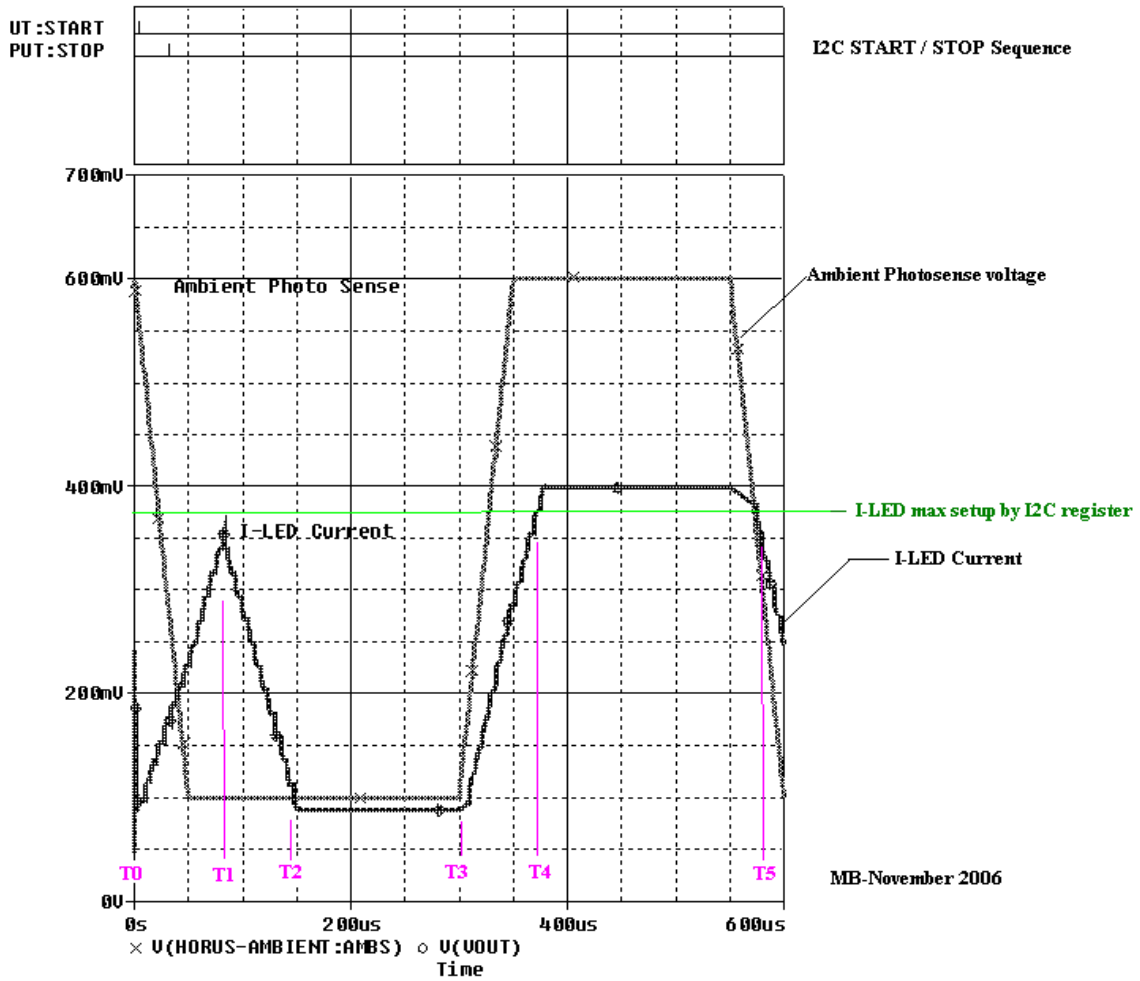

Figure 15. Basic Ambient Photo Sense Regulation (PSPICE simulation)

PWM Sequence

The three PWM can be controlled according to one of the possible sequence depicted in Figure 16. In all cases, the Main Display is powered first.

Strategy #1: the three PWM are fully synchronized and share the same timings, the rise and fall time being identical. At this point, the feedback voltage will rapidly swap from a low 400 mV (normal operation) to the large Vf span coming from the three LED added in series.

Strategy #2: the three PWM share the same rise and fall time, the sequence being synchronized but delayed until

the previous LED is at full power (PWM = 100%). This is the most stable sequence, from a human eye stand point, since we have a minimum blinking (one Vf variation only).

Strategy #3: the three PWM share the same rise and fall time but they can be activated independently.

Strategy #4: the three PWM operate randomly: the NCP5890 is capable of operating under such conditions, but care must be observed since such random PWM (as depicted by the circles) might be a stress from a human eye stand point.

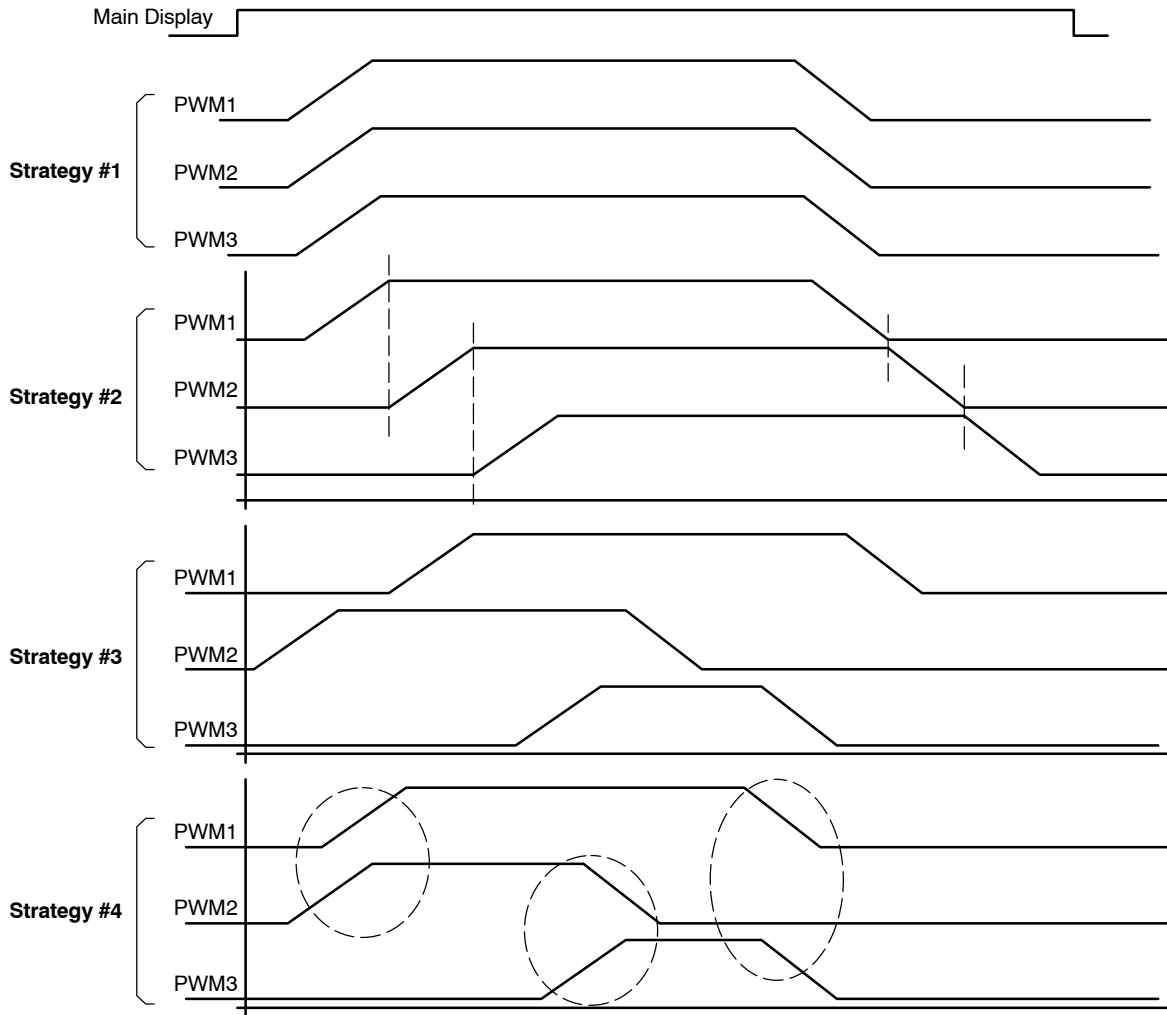

Figure 16. Basic PWM Sequences

NCP5890

In addition, the first PWM structure can control two LED in series as depicted in Figure 17. The next PWM pin is limited to 9.5 V and cannot accommodate over voltage during the operation.

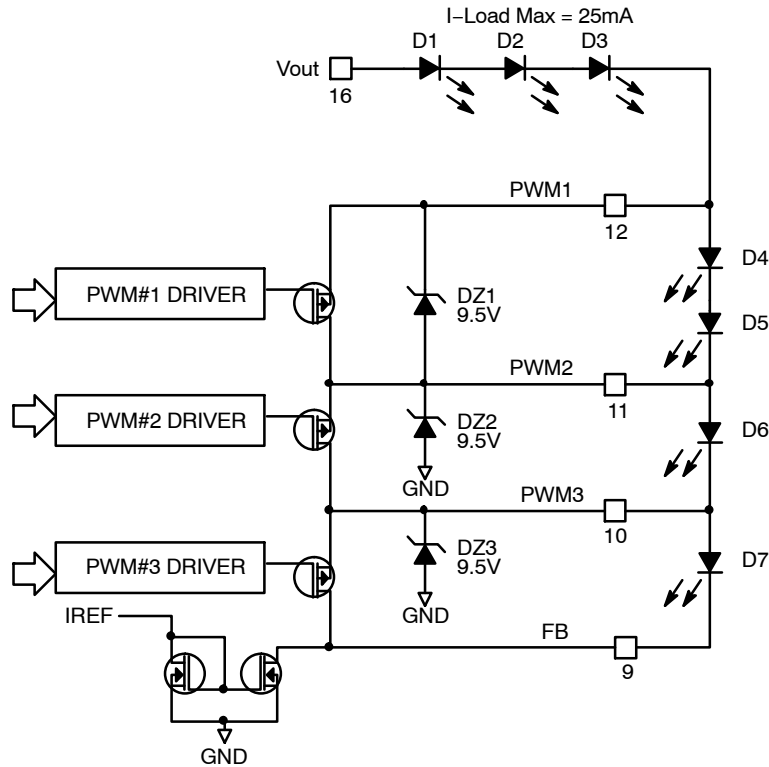

Figure 17. Basic PWM Internal Voltage Clamps

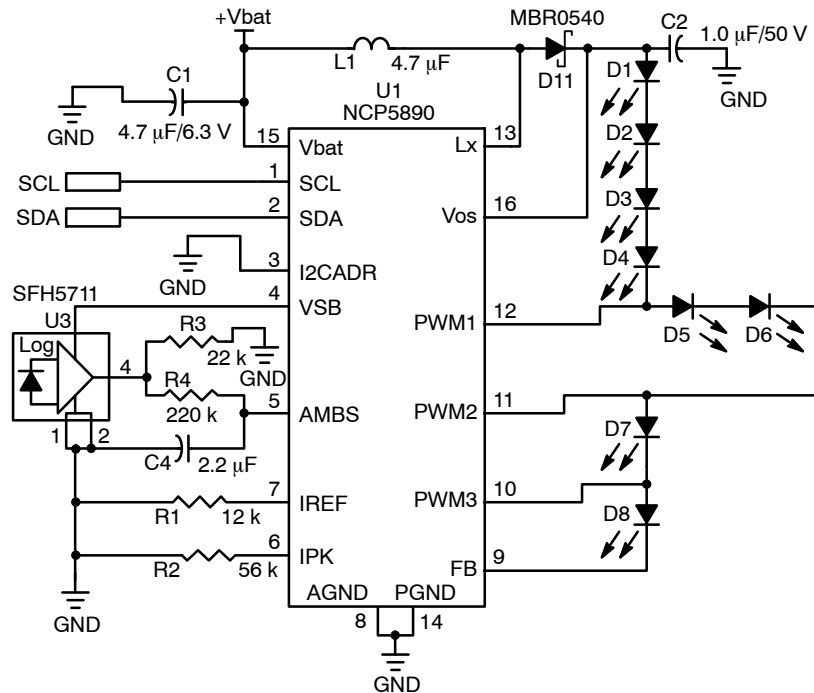

Figure 18. Serial PWM#1 Extension LED

NCP5890

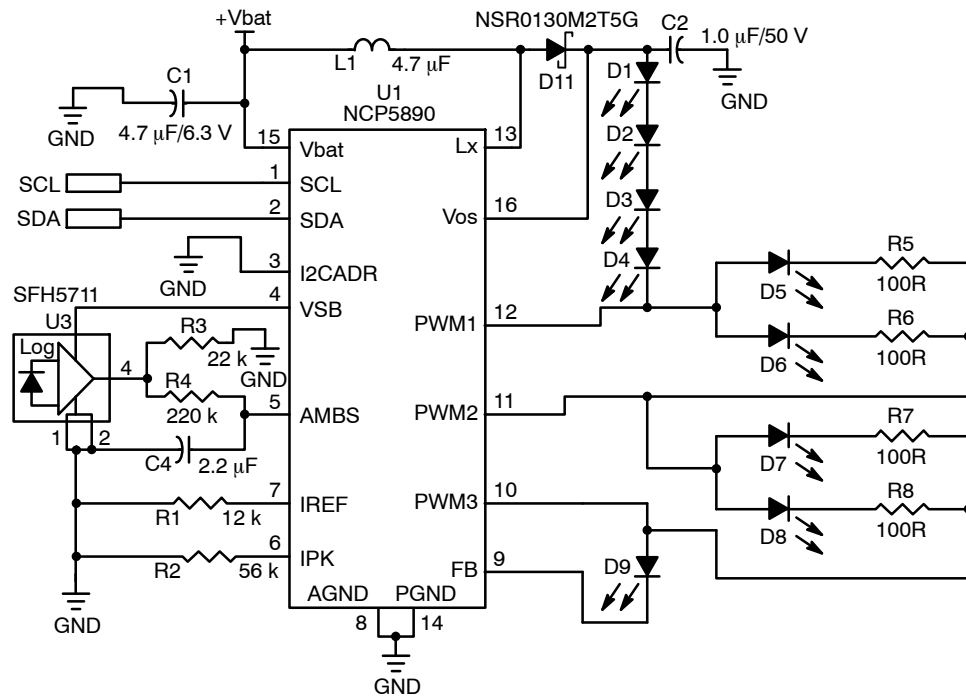

Figure 19. Paralleling Extension LED

ESD PROTECTION CIRCUIT

Depending upon the function of the pin, different circuitry is applied. The basic structures are illustrated in Figure 20.

Although the structures are capable to handle the ESD stresses (as defined by the JEDEC specifications), no current or voltage, either DC or AC, beyond the maximum ratings specifications shall be applied to any pin.

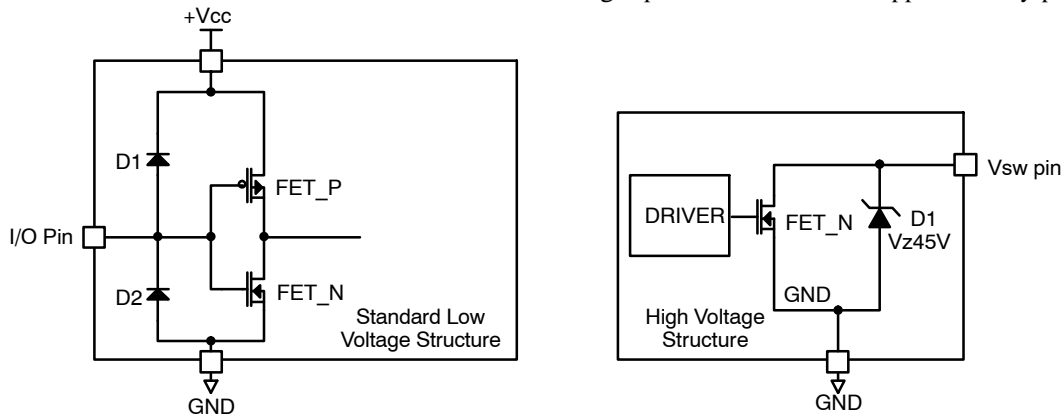

Figure 20. Typical ESD Protection Structures

UNDERVOLTAGE LOCKOUT

The VUVLO circuit is used to disconnect the chip when the input voltage is below the minimum operating value.

The system resumes to normal operation when the input voltage increases by the minimum value plus the hysteresis as specified in the data sheet.

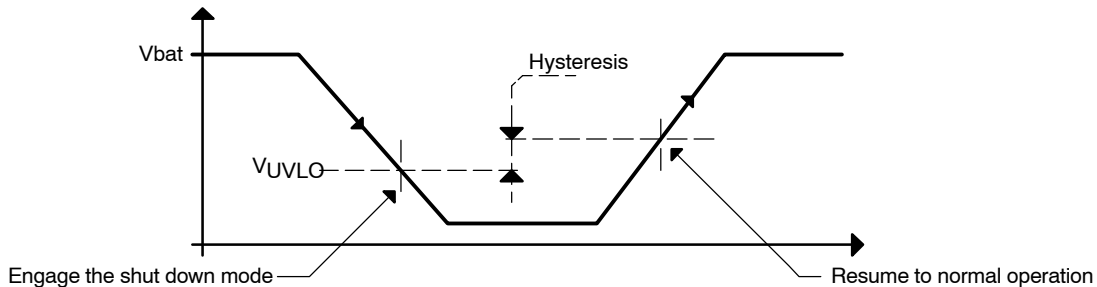
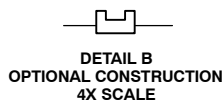
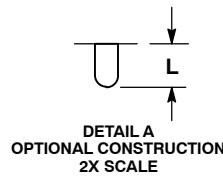
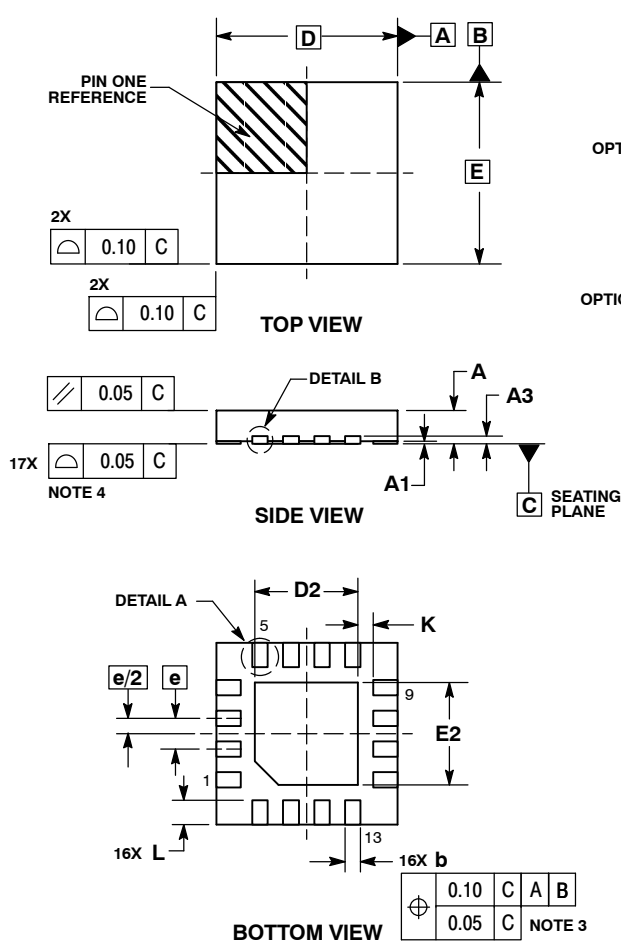

Figure 21. Undervoltage Lockout Basic Mechanism

NCP5890

PACKAGE DIMENSIONS

UQFN16 3x3, 0.5P
CASE 523AF-01
ISSUE O



NOTES:

1. DIMENSIONING AND TOLERANCING PER ASME Y14.5M, 1994.
2. CONTROLLING DIMENSION: MILLIMETERS.
3. DIMENSION b APPLIES TO PLATED TERMINAL AND IS MEASURED BETWEEN 0.15 AND 0.30 MM FROM TERMINAL TIP.
4. COPLANARITY APPLIES TO THE EXPOSED PAD AS WELL AS THE TERMINALS.

DIM	MILLIMETERS	
	MIN	MAX
A	0.45	0.60
A1	0.00	0.05
A3	0.127	REF
b	0.20	0.30
D	3.00	BSC
D2	1.60	1.80
E	3.00	BSC
E2	1.60	1.80
e	0.50	BSC
K	0.20	---
L	0.30	0.50

SOLDERING FOOTPRINT*

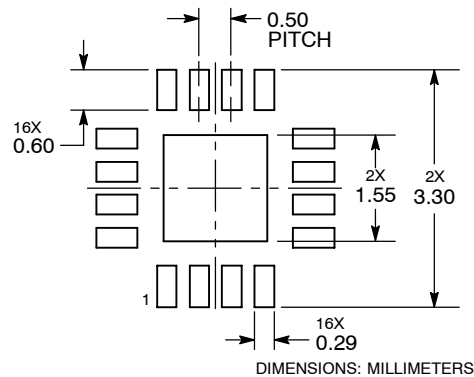

*For additional information on our Pb-Free strategy and soldering details, please download the ON Semiconductor Soldering and Mounting Techniques Reference Manual, SOLDERRM/D.

ON Semiconductor and are registered trademarks of Semiconductor Components Industries, LLC (SCILLC). SCILLC reserves the right to make changes without further notice to any products herein. SCILLC makes no warranty, representation or guarantee regarding the suitability of its products for any particular purpose, nor does SCILLC assume any liability arising out of the application or use of any product or circuit, and specifically disclaims any and all liability, including without limitation special, consequential or incidental damages. "Typical" parameters which may be provided in SCILLC data sheets and/or specifications can and do vary in different applications and actual performance may vary over time. All operating parameters, including "Typicals" must be validated for each customer application by customer's technical experts. SCILLC does not convey any license under its patent rights nor the rights of others. SCILLC products are not designed, intended, or authorized for use as components in systems intended for surgical implant into the body, or other applications intended to support or sustain life, or for any other application in which the failure of the SCILLC product could create a situation where personal injury or death may occur. Should Buyer purchase or use SCILLC products for any such unintended or unauthorized application, Buyer shall indemnify and hold SCILLC and its officers, employees, subsidiaries, affiliates, and distributors harmless against all claims, costs, damages, and expenses, and reasonable attorney fees arising out of, directly or indirectly, any claim of personal injury or death associated with such unintended or unauthorized use, even if such claim alleges that SCILLC was negligent regarding the design or manufacture of the part. SCILLC is an Equal Opportunity/Affirmative Action Employer. This literature is subject to all applicable copyright laws and is not for resale in any manner.

PUBLICATION ORDERING INFORMATION

LITERATURE FULFILLMENT:
Literature Distribution Center for ON Semiconductor
P.O. Box 5163, Denver, Colorado 80217 USA
Phone: 303-675-2175 or 800-344-3860 Toll Free USA/Canada
Fax: 303-675-2176 or 800-344-3867 Toll Free USA/Canada
Email: orderlit@onsemi.com

N. American Technical Support: 800-282-9855 Toll Free
USA/Canada
Europe, Middle East and Africa Technical Support:
Phone: 421 33 790 2910
Japan Customer Focus Center
Phone: 81-3-5773-3850

ON Semiconductor Website: www.onsemi.com

Order Literature: <http://www.onsemi.com/orderlit>

For additional information, please contact your local Sales Representative

NCP5890/D