

DESCRIPTION

M54583P and M54583FP are eight-circuit collector-current-synchronized Darlington transistor arrays. The circuits are made of PNP and NPN transistors. Both the semiconductor integrated circuits perform high-current driving with extremely low input-current supply.

FEATURES

- High breakdown voltage ($BV_{CEO} \geq 50V$)
- High-current driving ($I_c(\max) = 400mA$)
- Active L-level input
- With input clamping diodes
- Wide operating temperature range ($T_a = -20$ to $+75^\circ C$)

APPLICATION

Interfaces between microcomputers and high-voltage, high-current drive systems, drives of relays and printers, and MOS-bipolar logic IC interfaces

FUNCTION

The M54583 is produced by adding PNP transistors to M54523 inputs. Eight circuits having active L-level inputs are provided.

Resistance of $7k\Omega$ and diode are provided in series between each input and PNP transistor base. The input diode is intended to prevent the flow of current from the input to the Vcc. Without this diode, the current flow from "H" input to the Vcc and the "L" input circuits is activated, in such case where one of the inputs of the 8 circuits is "H" and the others are "L" to save power consumption. The diode is inserted to prevent such misoperation.

This device is most suitable for a driver using NMOS IC output especially for the driver of current sink.

Collector current is 400mA maximum. Collector-emitter supply voltage is 50V.

The 54583FP is enclosed in a molded small flat package, enabling space saving design.

PIN CONFIGURATION (TOP VIEW)

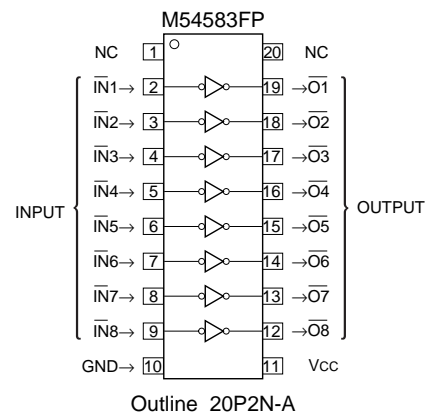
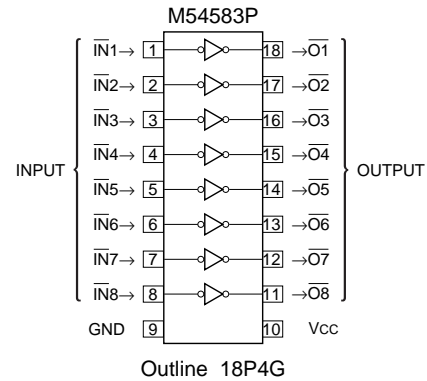

NC : No connection

CIRCUIT DIAGRAM (EACH CIRCUIT)

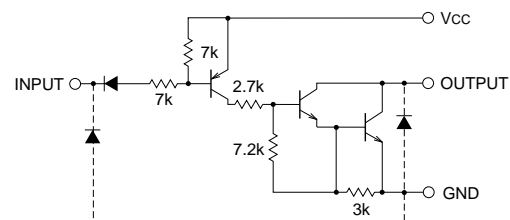

The eight circuits share the Vcc and GND.

The diode, indicated with the dotted line, is parasitic, and cannot be used.

Unit : Ω

ABSOLUTE MAXIMUM RATINGS (Unless otherwise noted, Ta = -20 ~ +75°C)

Symbol	Parameter	Conditions	Ratings	Unit
VCC	Supply voltage		10	V
VCEO	Collector-emitter voltage	Output, H	-0.5 ~ +50	V
Vi	Input voltage		-0.5 ~ Vcc	V
Ic	Collector current	Current per circuit output, L	400	mA
Pd	Power dissipation	Ta = 25°C, when mounted on board	1.79/1.1	W
Topr	Operating temperature		-20 ~ +75	°C
Tstg	Storage temperature		-55 ~ +125	°C

RECOMMENDED OPERATING CONDITIONS (Unless otherwise noted, Ta = -20 ~ +75°C)

Symbol	Parameter	Limits			Unit	
		min	typ	max		
VCC	Supply voltage	4	5	8	V	
Ic	Collector current Per channel	Vcc = 5V, Duty Cycle P : no more than 10% FP : no more than 5%	0	—	350	mA
		Vcc = 5V, Duty Cycle P : no more than 34% FP : no more than 15%	0	—	200	
VIH	"H" input voltage	Vcc-0.7	—	Vcc	V	
VIL	"L" input voltage	0	—	Vcc-3.6	V	

ELECTRICAL CHARACTERISTICS (Unless otherwise noted, Ta = -20 ~ +75°C)

Symbol	Parameter	Test conditions	Limits			Unit
			min	typ*	max	
V (BR) CEO	Collector-emitter breakdown voltage	ICEO = 100µA, VCC = 8V	50	—	—	V
VCE (sat)	Collector-emitter saturation voltage	VI = VCC-3.6V	—	1.1	2.2	V
		Ic = 350mA Ic = 200mA	—	0.98	1.6	
Ii	Input current	VI = VCC-3.6V	—	-320	-600	µA
ICC	Supply current (one circuit coming on)	VCC = 5V, VI = VCC-3.6V	—	—	3	mA
hFE	DC amplification factor	VCE = 4V, VCC = 5V, Ic = 350mA, Ta = 25°C	2000	10000	—	—

* : The typical values are those measured under ambient temperature (Ta) of 25°C. There is no guarantee that these values are obtained under any conditions.

SWITCHING CHARACTERISTICS (Unless otherwise noted, Ta = 25°C)

Symbol	Parameter	Test conditions	Limits			Unit
			min	typ	max	
ton	Turn-on time	CL = 15pF (note 1)	—	130	—	ns
toff	Turn-off time		—	3200	—	ns

NOTE 1 TEST CIRCUIT

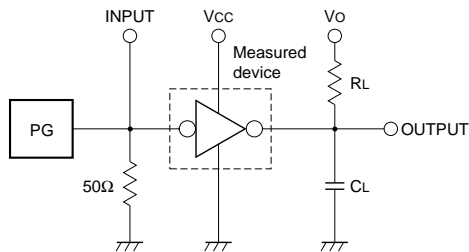

- (1) Pulse generator (PG) characteristics : PRR = 1kHz, tw = 10µs, tr = 6ns, tf = 6ns, Zo = 50Ω, Vi = 0.4 to 4V
- (2) Input-output conditions : RL = 30Ω, Vo = 10V, VCC = 4V
- (3) Electrostatic capacity CL includes floating capacitance at connections and input capacitance at probes

TIMING DIAGRAM

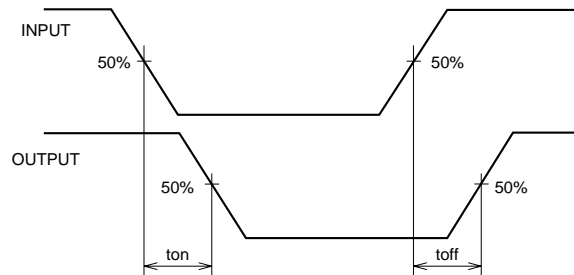

TYPICAL CHARACTERISTICS

Thermal Derating Factor Characteristics

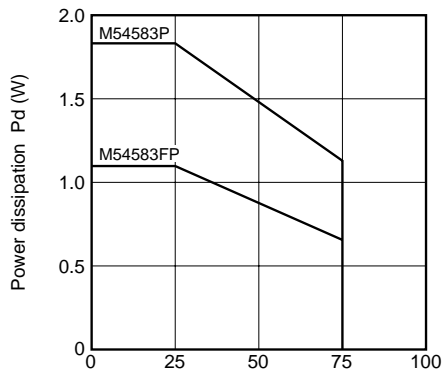

Ambient temperature T_a (°C)

**Output Saturation Voltage
Collector Current Characteristics**

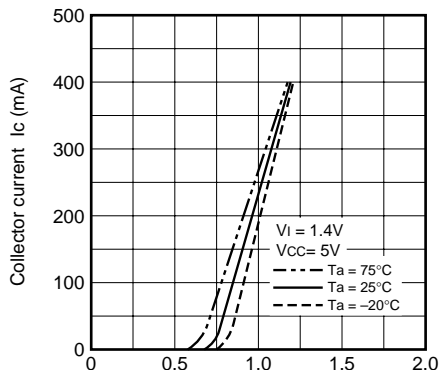

Output saturation voltage $V_{CE(sat)}$ (V)

**Duty-Cycle-Collector Characteristics
(M54583P)**

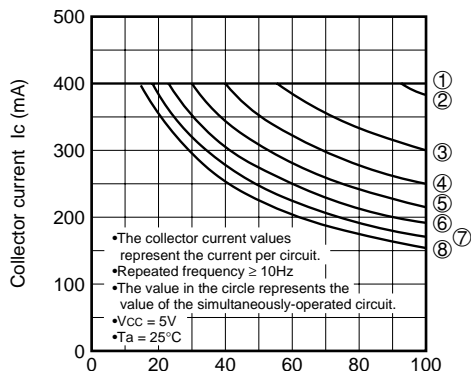

Duty cycle (%)

**Duty-Cycle-Collector Characteristics
(M54583P)**

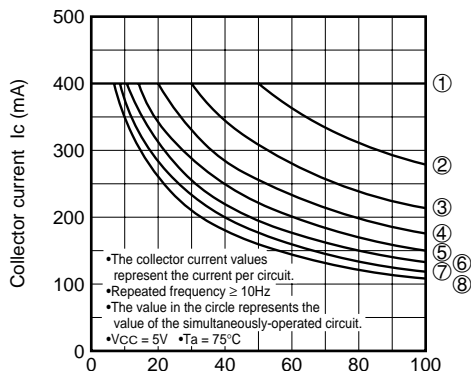

Duty cycle (%)

**Duty-Cycle-Collector Characteristics
(M54583FP)**

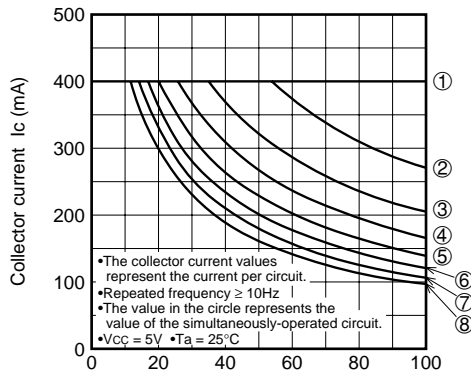

Duty cycle (%)

**Duty-Cycle-Collector Characteristics
(M54583FP)**

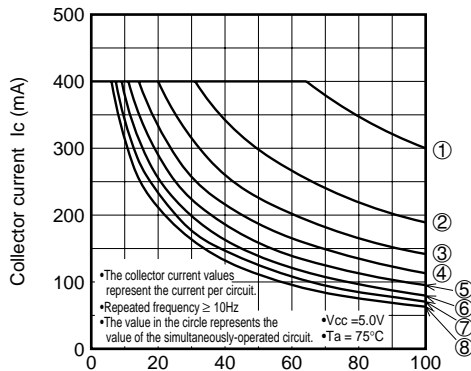

Duty cycle (%)

Input Characteristics

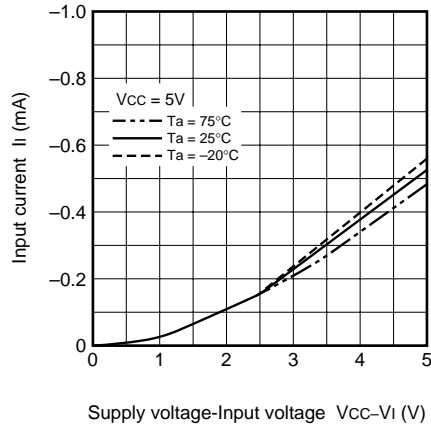

**DC Amplification Factor
Collector Current Characteristics**

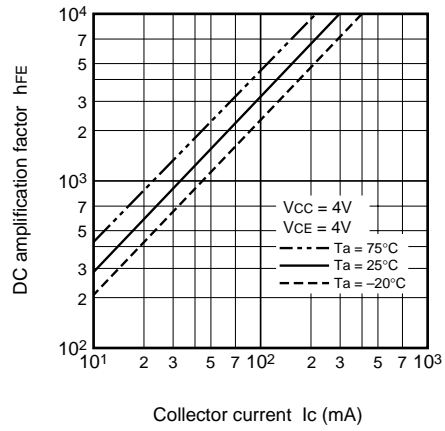

Grounded Emitter Transfer Characteristics

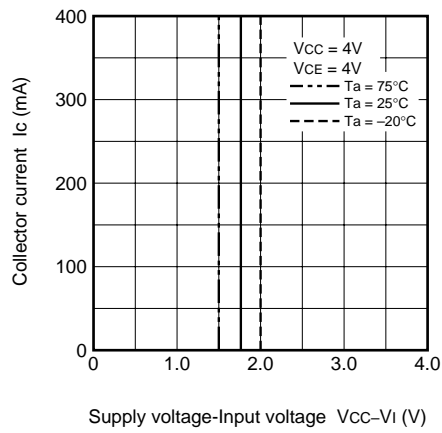

Supply Current Characteristics

