

AN8032

Active filter control IC

■ Overview

In supplying electric power from commercial power supply to various electrical equipment, there is a possibility that the harmonic distortion generated in the power line may give obstruction to the power facilities or other electrical equipment. The use of active filter is one of the methods to solve the harmonic distortion problems.

The AN8032 is a monolithic IC which incorporates the control and protection functions into one package so that the active filter can be constructed easily. It is most suitable for the measures against the harmonic distortion problems such as lighting equipment.

■ Features

- Self-excited peak current mode is adapted.
- Built-in protection circuit for preventing the overvoltage generated under a small load
- Easy constant setting with enlarged dynamic range of multiplier and error amplifier.
- Overvoltage protection terminal separately set to pass the short test of the safety standards
- Using totem pole output circuit which allows the power MOSFET to be directly driven.
- Built-in low voltage protection circuit which ensures the on-resistance during the power MOSFET operation.
- Timer circuit is built in for realizing automatic start.

■ Applications

- Lighting equipment and switching power supply equipment

■ Block Diagram

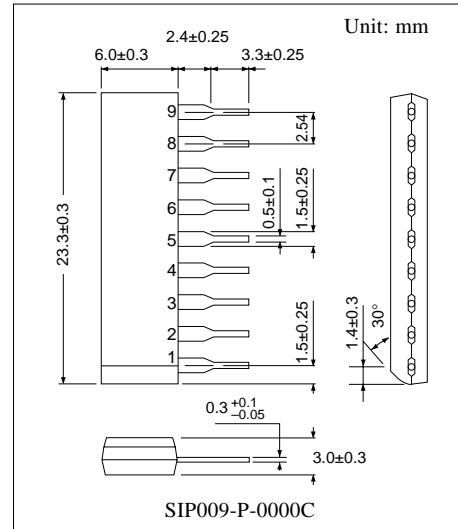
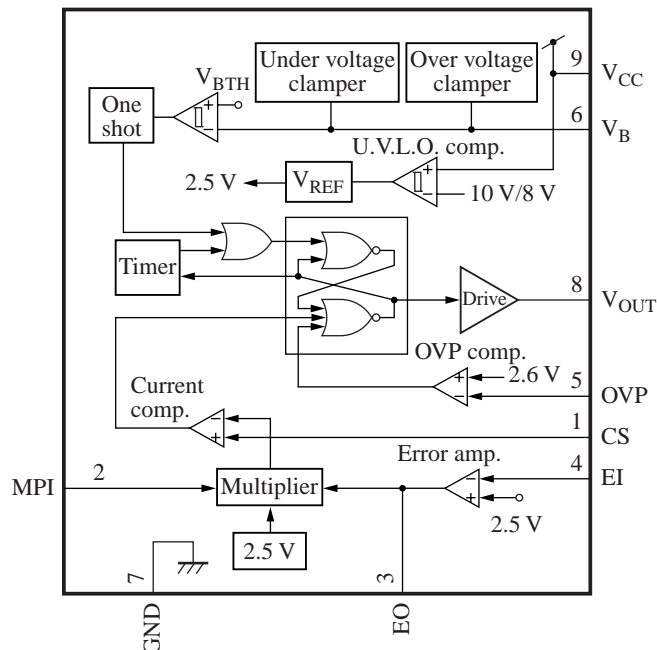

■ Pin Descriptions

Pin No.	Symbol	Description
1	CS	Comparator input pin
2	MPI	Multiplier input pin
3	EO	Error amplifier output pin / multiplier input pin
4	EI	Error amplifier inverted-input pin
5	OVP	Overvoltage detection pin
6	V _B	Transformer-reset detection pin
7	GND	Grounding pin
8	V _{OUT}	Output pin
9	V _{CC}	Power supply-voltage pin

■ Absolute Maximum Ratings

Parameter	Symbol	Rating	Unit
Supply voltage	V _{CC}	35	V
CS allowable application voltage	V _{CS}	-0.5 to +7	V
MPI allowable application voltage	V _{MPI}	-0.5 to +7	V
EI allowable application voltage	V _{EI}	-0.5 to +7	V
Output allowable current	I _O	±150	mA
Peak output current	I _{OP}	±1	A
V _B allowable flow-in current	I _{BI}	+5	mA
V _B allowable flow-out current	I _{BO}	-5	mA
Power dissipation	P _D	874	mW
Operating ambient temperature *	T _{opr}	-30 to +85	°C
Storage temperature *	T _{stg}	-55 to +150	°C

Note) *: Expect for the operating ambient temperature and storage temperature, all ratings are for T_a = 25°C.

■ Recommended Operating Range

Parameter	Symbol	Range	Unit
Supply voltage	V _{CC}	0 to 34	V

■ Electrical Characteristics at T_a = 25°C

Parameter	Symbol	Conditions	Min	Typ	Max	Unit
Error detection feedback threshold voltage 1	V _{EITH1}		2.35	2.50	2.65	V
Error detection low-level output voltage	V _{EOL}	I _{EO} = 0 mA, V _{EI} = 5 V	—	1.0	1.6	V
Error detection high-level output voltage	V _{EOH}	I _{EI} = 0 mA, V _{EI} = 0 V	5.0	5.7	—	V
Error detection input bias current	I _{EI}	V _{EI} = 0 V	—	-0.3	-1.0	μA
Error detection output supply current	I _{EO}	V _{EI} = 0 V, V _{EO} = 1 V	0.25	0.50	0.75	mA

■ Electrical Characteristics (continued) at $T_a = 25^\circ\text{C}$

Parameter	Symbol	Conditions	Min	Typ	Max	Unit
Multiplier input D-range (upper limit)	V_{MPIH}	$V_{\text{EO}} = 5 \text{ V}$	4.0	4.5	—	V
Multiplier output D-range (upper limit)	V_{MPOH}	$V_{\text{EO}} = 5 \text{ V}$	4.8	5.4	—	V
Multiplier gain	G_{MP}		1.0	1.2	1.4	1/V
Multiplier input bias current	I_{MPI}	$V_{\text{MPI}} = 0 \text{ V}$	—	-1.5	-3.0	μA
Coil detection input threshold voltage	V_{BTH}		1.2	1.5	1.8	V
Coil detection hysteresis width	dV_{B}		50	100	200	mV
Coil detection high-level clamp voltage	V_{BH}	$I_{\text{B}} = 5 \text{ mA}$	7.0	7.5	8.0	V
Coil detection low-level clamp voltage	V_{BL}	$I_{\text{B}} = -5 \text{ mA}$	-0.3	-0.2	0	V
Current detection input offset voltage	V_{CSOFF}		—	3.5	15	mV
Current detection input bias current	I_{CS}	$V_{\text{CS}} = 0 \text{ V}$	—	-0.5	-2.0	μA
Overvoltage detection input threshold voltage	V_{OVP}		2.45	2.60	2.75	V
$V_{\text{OVP}} - V_{\text{EITH1}}$	—		70	100	130	mV
Low-level output voltage	V_{OUTL}	$I_{\text{OUT}} = 100 \text{ mA}$	—	0.9	1.5	V
High-level output voltage	V_{OUTH}	$I_{\text{OUT}} = -100 \text{ mA}$	9.2	10.2	—	V
Standby output voltage	V_{OUTSTB}	$I_{\text{OUT}} = 10 \text{ mA}$	—	0.8	1.5	V
U.V.L.O. start voltage	V_{CCST}		9.2	10.0	10.8	V
U.V.L.O. stop voltage	V_{CCSP}		7.0	8.0	9.0	V
U.V.L.O. start - stop voltage difference	dV_{CC}	$dV_{\text{CC}} = V_{\text{CCST}} - V_{\text{CCSP}}$	1.75	2.00	2.50	V
Standby current	I_{CCSTB}	$V_{\text{CC}} = 7 \text{ V}$	40	80	120	μA
Operation current without load	I_{CC}	$V_{\text{CC}} = 12 \text{ V}$	—	6.0	10.0	mA

• Design reference data

Note) The characteristics listed below are reference values based on the IC design and are not guaranteed.

Parameter	Symbol	Conditions	Min	Typ	Max	Unit
Error detection feedback threshold voltage 2	V_{EITH2}	$T_a = -25^\circ\text{C}$ to $+85^\circ\text{C}$	2.3		2.7	V
Error detection open-loop gain	G_{AV}			85		dB
Error detection gain band width	f_{BW}			1.0		MHz
Multiplier input D-range (lower limit)	V_{MPIL}	$V_{\text{EO}} = 5 \text{ V}$		0		V
Multiplier output D-range (lower limit)	V_{MPOL}	$V_{\text{EO}} = 5 \text{ V}$		0		V
Current detection – output delay	t_{dCS}			200		ns
Overvoltage detection – output delay	t_{dOVP}			500		ns
Output rise time	t_{r}	$V_{\text{CC}} = 12 \text{ V}$, $V_{\text{OUT}} = 10\% \rightarrow 90\%$		50		ns
Output fall time	t_{f}	$V_{\text{CC}} = 12 \text{ V}$, $V_{\text{OUT}} = 90\% \rightarrow 10\%$		50		ns
Timer delay time	t_{dTIM}			400		μs

■ Terminal Equivalent Circuits

Pin No.	Equivalent circuit	Description	I/O
1	<p>Approx. 7.1 V</p>	<p>CS:</p> <p>The input terminal of comparator which detects the current value flowing in power MOSFET.</p> <p>The output level of multiplier and the current value of power MOSFET input from the CS terminal are compared. If the later becomes larger than the former, the V_{OUT} is set to low level and the power MOSFET output is cut.</p>	I
2	<p>Approx. 7.1 V</p>	<p>MPI:</p> <p>The input terminal of multiplier</p> <p>The voltage after a full-wave rectified AC input voltage are monitored.</p>	I
3	<p>Approx. 7.1 V</p> <p>Approx. 7.1 V</p> <p>Error amplifier output</p> <p>Multiplier input</p>	<p>EO:</p> <p>The output terminal of error amplifier / the input terminal of multiplier.</p> <p>The error amplifier monitors the output voltage of active filter and amplifies its error portion and outputs to the multiplier. Therefore, this terminal serves as another input terminal of the multiplier.</p>	O
4	<p>Approx. 7.1 V</p> <p>Approx. 7.1 V</p> <p>Error amplifier input</p>	<p>EI:</p> <p>The inverted input terminal of error amplifier the overvoltage protection input terminal.</p> <p>To the noninverted input terminal, the internal reference voltage of IC (2.5 V typ.) is input.</p>	I
5	<p>Approx. 7.1 V</p> <p>Approx. 7.1 V</p> <p>Overvoltage protection input</p>	<p>OVP:</p> <p>Overvoltage detection pin</p> <p>It is an input terminal with over-voltage detection function which can detect the overvoltage of the output voltage to shut off the power MOSFET.</p>	I

■ Terminal Equivalent Circuits (continued)

Pin No.	Equivalent circuit	Description	I/O
6	<p>The diagram shows a circuit for Pin 6. It includes a PVCC input connected to a network of transistors and resistors. Two dashed boxes indicate 'Upper limit voltage clamp' and 'Lower limit voltage clamp', both labeled 'Approx. 7.1 V'. A 'V_B Comparator input' is also shown.</p>	<p>V_B: The terminal is connected via the transformer's sub-coil and resistor. The reset of transformer is detected and the trigger signal to turn on the power MOSFET is sent.</p> <p>Since the coil signal of transformer is input as current, the IC incorporates the circuit which clamps the upper/lower limit voltage to prevent malfunction.</p>	I
7	<p>The diagram shows Pin 7 connected to two ground terminals: 'Power system ground' and 'Signal system ground'.</p>	<p>GND: Grounding terminal</p> <p>This terminal is used in common for grounding the control system and the power system.</p>	—
8	<p>The diagram shows a power MOSFET gate drive circuit. Terminal 9 is connected to the gate of the MOSFET. Terminal 8 is connected to the drain of the MOSFET. The MOSFET is driven by a network of transistors and resistors.</p>	<p>V_{OUT}: The output terminal.</p> <p>It is capable of driving the gate of power MOSFET directly.</p>	O
9	<p>The diagram shows Pin 9 connected to a 'U.V.L.O.' block, a 'V_B Upper limit voltage clamp', and a 'Power MOSFET drive block'. An 'Inside bias (Approx. 7.1 V)' is also indicated.</p>	<p>V_{CC}: The supply voltage terminal.</p> <p>The supply voltage terminal for the power system and that for the signal system are put together as one terminal with internal connection in order to greatly decrease the common impedance.</p> <p>This double-functioning terminal monitors the supply voltage, and has start/stop operation threshold.</p>	—

■ Application Notes

[1] $P_D - T_a$ curve of SIP009-P-0000C

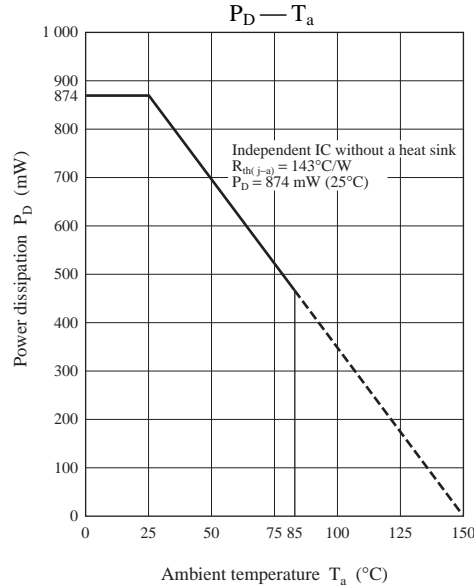

[2] Operation descriptions

1. Normal control

1) Application outline

As shown in figure 1, the standard application of the AN8032 is a booster chopper circuit, which inputs the voltage rectified from the commercial supply of 100 V/200 V (A in figure 1) and outputs the DC voltage of 400 V (B in figure 1).

It controls so that the input current proportional to the input voltage (C, D in figure 1) could be flown.

The reason for selecting the output voltage of 400 V is that the withstanding voltage of components and the operation limitation of booster chopper (input voltage < output voltage) under the worldwide input voltage are taken into consideration.

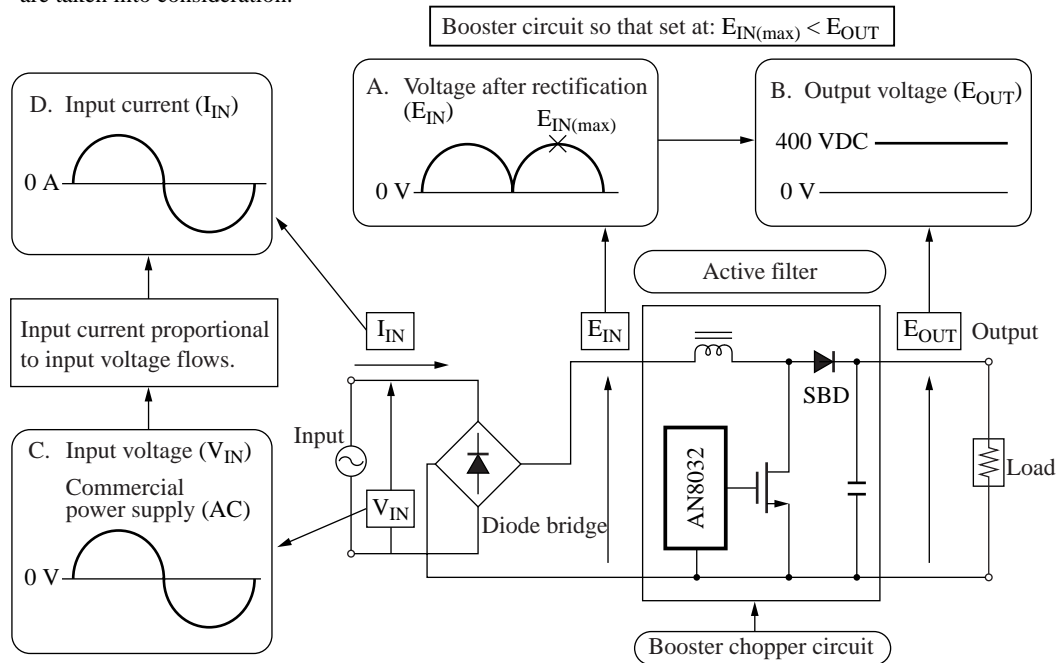

Figure 1. Application outline description

■ Application Notes (continued)

[2] Operation descriptions (continued)

1. Normal control (continued)

2) Control outline description (Refer to figure 2 and figure 3.)

(1) Input voltage (E_{IN}) detection

The voltage which is divided from the input voltage of chopper circuit (E_{IN}) by using the external resistor is input to the multiplier input terminal of the AN8032 (MPI terminal).

(2) Output voltage (E_{OUT}) detection

The voltage which is divided from the output voltage of chopper circuit (E_{OUT}) by using the external resistor is amplified by the error amplifier of the AN8032 (Input to noninverting input terminal (EI terminal)) and input to another multiplier input (EO terminal, which also functions as output for error amplifier).

(3) Multiplication of input voltage and output voltage

The signals input to the multiplier are multiplied and outputted from the multiplier. This output is a signal which monitors both the input voltage and output voltage of the chopper circuit.

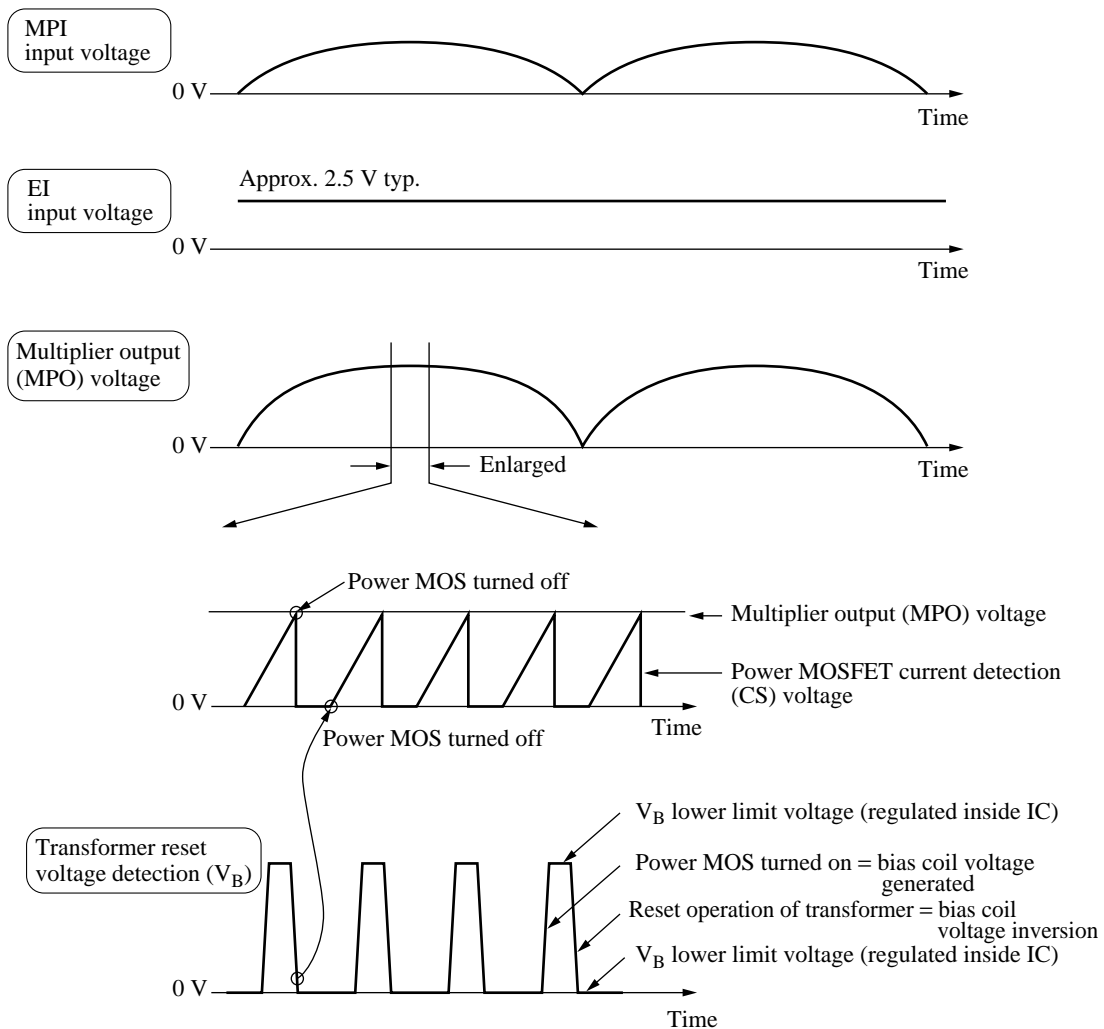

Figure 2. Explanation of normal control operation

■ Application Notes (continued)

[2] Operation descriptions (continued)

1. Normal control (continued)

2) Control outline description (Refer to figure 2 and figure 3.) (continued)

(4) Switching device current

The voltage generated in the current detection resistor which is connected to the switching device (power MOSFET) is detected at the CS terminal. (for the above resistor, low resistance value is selected, considering the power dissipation).

(5) Switching device turn-off

The CS terminal voltage and the multiplier output voltage are compared by the current detection comparator. When the former value becomes larger than the latter one, the current detection comparator sends the reset signal to the RS latch circuit to turn off the switching device.

(6) Output current supply

When the switching device is turned off, the current flowing in the transformer is cut off. The diode is turned-on with inertia current of inductor, and supplies a current to the output of chopper circuit (E_{OUT}).

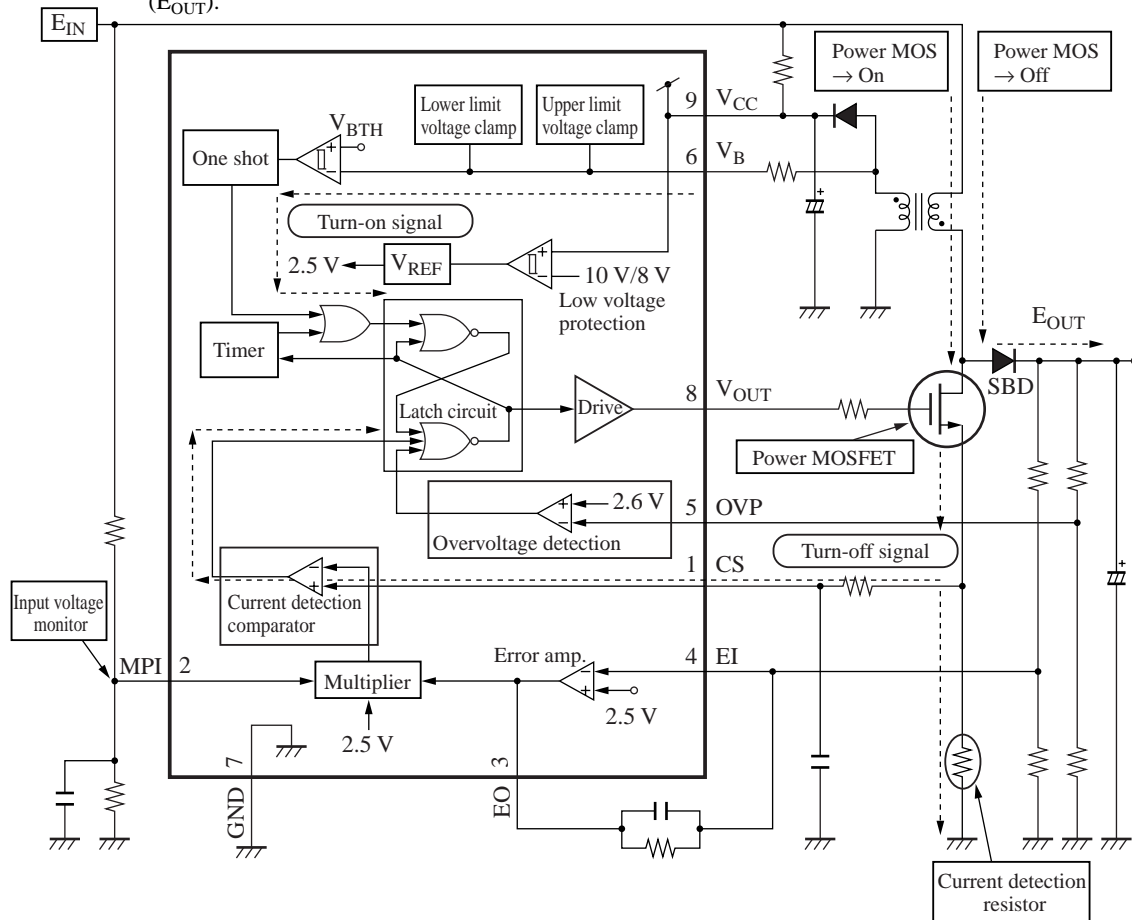

Figure 3. Explanation of block diagram and normal operation

(7) Transformer reset signal (V_B) detection

When the excitation energy has been discharged and the inertia current of the inductor has been lost, the transformer starts resonance with the frequency which depends on parasitic capacitance of the board or parts and inductance of the inductor. This operation is detected at the V_B terminal through sub-coil of the transformer.

■ Application Notes (continued)

[2] Operation descriptions (continued)

1. Normal control (continued)

2) Control outline description (Refer to figure 2 and figure 3.) (continued)

(8) Switching device turn-on

By resonance, the turn-on signal is sent to the switching device, timed with the sub-coil voltage when it swings from high to low.

(9) Continuation of operation

When the switching device is turned on, current flows in the inductor so that the above operation is repeated.

<Summary>

- When the excitation energy of inductor is lost and the free resonance is started, the switching device turns on.
- The switching device will turn off when the following two elements cross each other: The product of the input voltage (E_{IN}) and output one (E_{OUT}) of the chopper circuit, and the switching device current.
- The fluctuation of input voltage and load current is controlled by changing the peak value height of switching device current.
- The purposes of mixing two signals by using the multiplier are:
 - to stabilize the control system
 - to reduce the number of components required

3) Description of each function

(1) V_B

• Function

It detects the discharge of the excitation energy of the inductor (reset operation) and turns on the power MOSFET at the next cycle.

• Method

When the inductor is reset, the sub-coil provided on the inductor (bias winding) starts free resonance. It is difficult from the view point of withstanding voltage to input this voltage directly to the IC. For this reason, it is input to the V_B terminal through resistor.

• Function of upper limit voltage clamper

It prevents the damage when the V_B terminal voltage exceeds the withstanding voltage.

Function of lower limit voltage clamper

It prevents the malfunction when the V_B terminal voltage swings to negative voltage: generally, in the case of monolithic IC, malfunction (such as latch-up) occurs when the terminal voltage decreases to a value below $-V_{BE}$ and the parasitic device is activated.

• IC inside

The V_B terminal voltage is input to the comparator with hysteresis inside the IC. For this reason, if the V_B terminal voltage is under the threshold value, the power MOSFET is turned on.

However, if the off signal has been given to the power MOSFET by the overvoltage protection function, this function precedes the former.

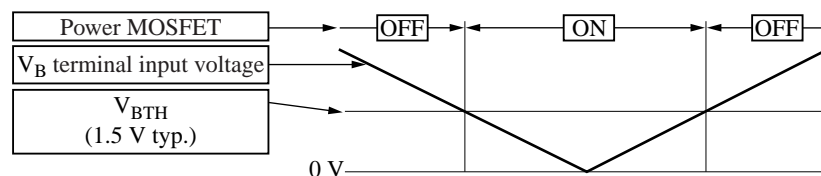

Figure 4. V_B terminal description

■ Application Notes (continued)

[2] Operation descriptions (continued)

1. Normal control (continued)
- 3) Description of each function (continued)
 - (1) V_B (continued)

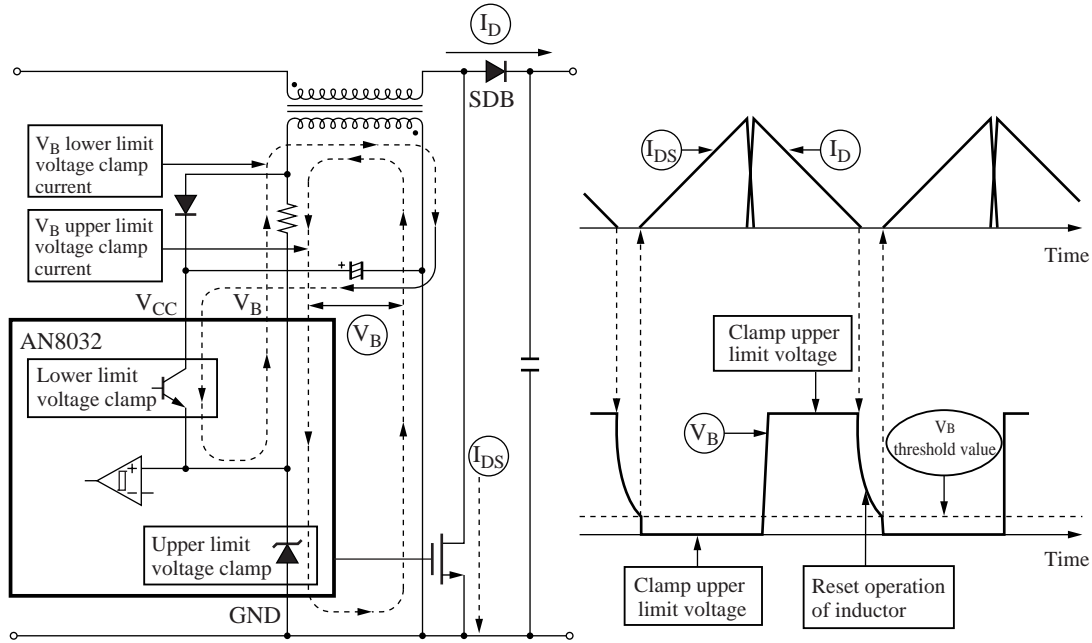
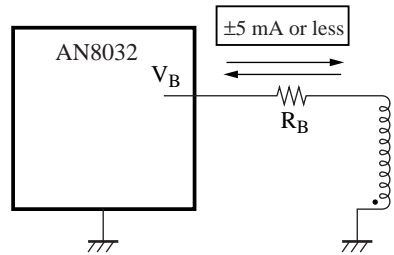

Figure 5. Explanation of V_B operation

<Setting the V_B terminal constant>

- Regulation by clamper in/out-current value

The allowable output current of the upper limit voltage clamper is -5 mA and the allowable input current of the lower limit voltage clamper is $+5\text{ mA}$. Either one of these allowable values is exceeded, the voltage clamp operation of the V_B terminal is not guaranteed. Therefore, R_B should be set so that these values are not exceeded.



- Consumption current and delay

When the R_B value is too large, the V_B threshold could be exceeded. When the R_B value is too small, the consumption current becomes too large.

In order to determine the R_B value properly, the input voltage range and the dispersion of components should be taken into consideration and it should be confirmed that a stable operation can be ensured under start/overload conditions or under a small load condition.

R_B too large: Consumption current becomes small, however, T_{OFF} is extended by the delay amount because of low speed.

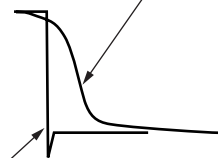

R_B too small: Speed is high, however, consumption current is small and undershoot tends to be generated easily.

■ Application Notes (continued)

[2] Operation descriptions (continued)

1. Normal control (continued)

3) Description of each function (continued)

(1) V_B (continued)

<Setting the V_B terminal constant> (continued)

• Zero-cross switching

Zero-cross switching can be realized by using the local resonance when turning on the power MOSFET in order to suppress the loss.

By connecting the resonance capacitor C_P between the drain and source of the power MOSFET, and using the inductance of the transformer's primary side L_P , the resonance is produced after discharging the accumulated energy of the transformer. The capacitor for delay should be connected to the V_B terminal so that the next turn-on could occur at the time when the resonance occurred and the drain voltage of the power MOSFET has reached around 0 V.

However, it is necessary to take care that the zero-cross conditions could deviate since the delay amount varies depending on the conditions such as the input voltage.

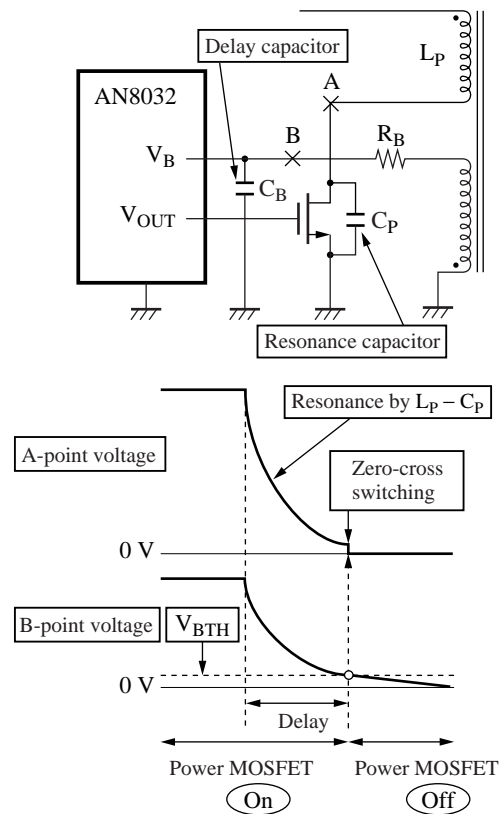

(2) CS

The terminal for detecting the current when the power MOSFET is turned on.

The current flow when the power MOSFET is turned on is equivalent to the current flow in the inductor. Therefore, the necessary power value can be controlled by controlling the peak value of the above current.

The input D-range of this terminal is from 0 V to 5 V. However, since dissipation becomes larger if the power MOSFET current detecting resistance is set at larger value. A value from 0.22 Ω to 0.47 Ω is the standard considering the relationship with the S/N.

The charge and discharge current to and from the parasitic capacitance of the power MOSFET, transformer or printed circuit wiring flow in the power MOSFET detection resistor at turning-on and off. Since such current generates noise and causes malfunction, it is necessary to incorporate a filter to remove such irregular element.

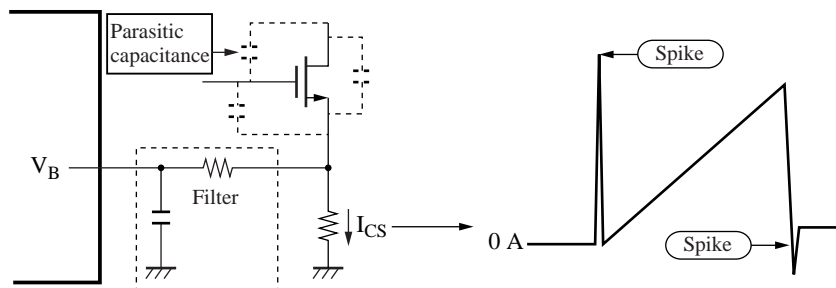

Figure 6. CS terminal explanation

(3) MPI

The MPI is the terminal for monitoring the AC input voltage. The voltage which is resistance-divided from the input voltage after full-wave rectification is input. The input D-range of the multiplier is from 0 V to 4.5 V typical and output D-range is from 0 V to 5.4 V typical.

■ Application Notes (continued)

[2] Operation description (continued)

1. Normal control (continued)
- 3) Description of each function (continued)
- (4) EI/EO

The resistance-divided voltage of the active filter output is input to the EI. The EI is the error amplifier's inverted input, and the temperature-compensated reference voltage (2.5 V typical) is input as the noninverted input. The error amplifier amplifies the error amount between the output voltage, and the reference voltage and outputs to the multiplier. The resistor between the EI and EO is used for determining the gain of error amplifier.

As for the resistance-dividing for decreasing the active filter's output voltage to the input D-range of EI, if an attempt is made to use a small-sized resistor for suppressing the dissipation, its resistance value becomes high because of the high output voltage. For this reason, note that if the capacitance inserted between the EI and EO for phase compensation is large, the delay element between it and the resistance-divider of high resistance becomes large, so that the characteristics at the time of sudden change of load (overshoot or undershoot) is degraded.

Therefore, as the value for phase compensation capacitor, select the minimum value with which the oscillation can be prevented.

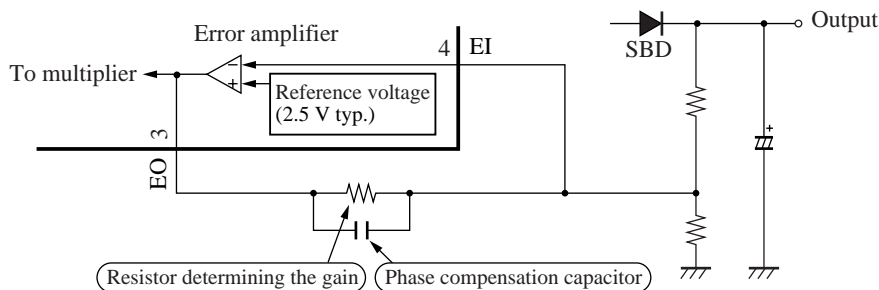

Figure 7. EI/EO terminal description

(5) V_{OUT}

For the drive circuit, the AN8032 employs the totem pole type by which the power MOSFET can be directly driven. Since the peak output current is ± 1 A, the TO-220 class power MOSFET can be driven. For the TOP-3 class, the buffer circuit should be added outside because its capability is not sufficient for that class.

The power MOSFET momentarily swings to minus due to the parasitic capacitance between the drain and gates at the time of turn-off and this causes malfunction in some cases. Therefore, the Schottky barrier diode should be inserted between the V_{OUT} and GND if necessary.

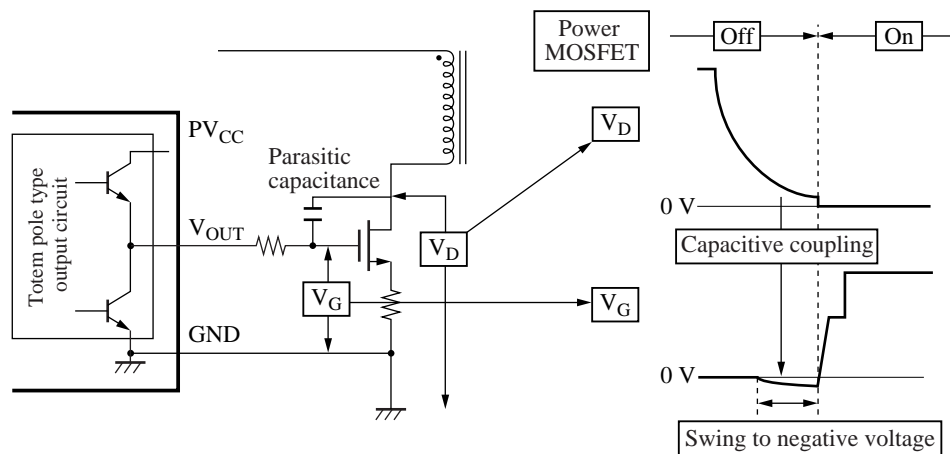

Figure 8. V_{OUT} terminal description

■ Application Notes (continued)

[2] Operation descriptions (continued)

1. Normal control (continued)

3) Description of each function (continued)

(6) V_{CC}

The supply voltage terminal other than the output. The U.V.L.O. depends on this V_{CC} voltage. (The characteristics of U.V.L.O. are shown in the right figure.)

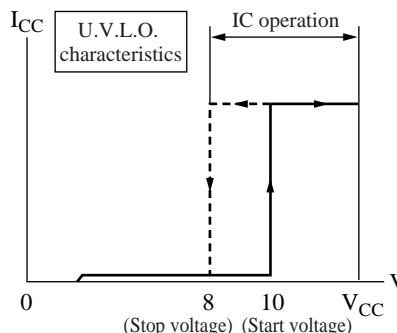

<Notes on the methods of providing V_{CC} >

- The method to give bias from sub-coil

There is only 2 V typical difference between the start voltage 10 V typical and the stop voltage 8 V typical. Be careful that the value for C1 shown in the right figure must be set at a large value, otherwise, the IC does not easily start.

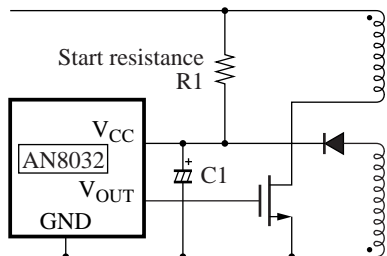

- Giving bias from power supply

In the case such as of fluorescent lamp inverter circuit, separate power supply is provided so as to give the bias from the separate power supply.

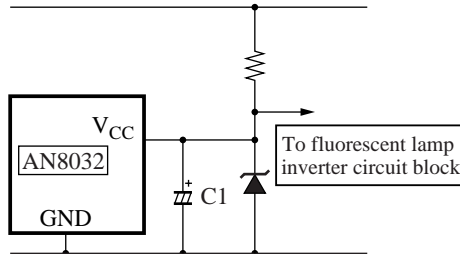

< V_{CC} interference>

For the AN8032, the following method is used to suppress the interference between the two power supply lines : The supply voltage supply line of the power system and that for the signal line are separately provided in the IC chip and they are put together when wired to the pin of the package. Thus the interference between 2 power supply lines is suppressed.

The same method is also used for the GND line. However, the above method can not prevent all the malfunctions due to noise. Therefore, in regard to the current pass in which the drive current of the power MOSFET flows, the pattern wiring should be provided as short as possible, in the same way as conventional practice to suppress the invasion of noise of the drive system.

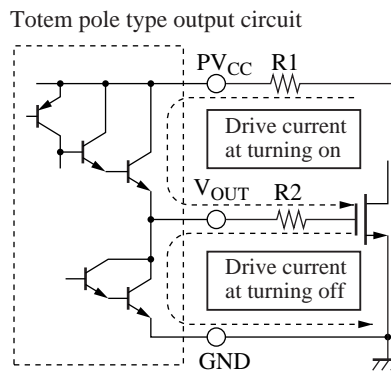

■ Application Notes (continued)

[2] Operation descriptions (continued)

2. Protection circuit

1) Timer

In control of this IC, the chopper circuit does not start unless the first on-signal is input to the switching device. The chopper circuit does not re-start, if the turn-on timing of switching device is missed due to some abnormality.

For the above reasons, this IC is incorporating the timer circuit and generating the start pulse once in every approx. 400 μs (typical) when the chopper circuit stops, eliminating the need for an external part to cope with this problem. (Refer to figure 9.) However, in order to prevent the output rise of the chopper circuit, the timer circuit does not operate as long as the overvoltage protector is operating.

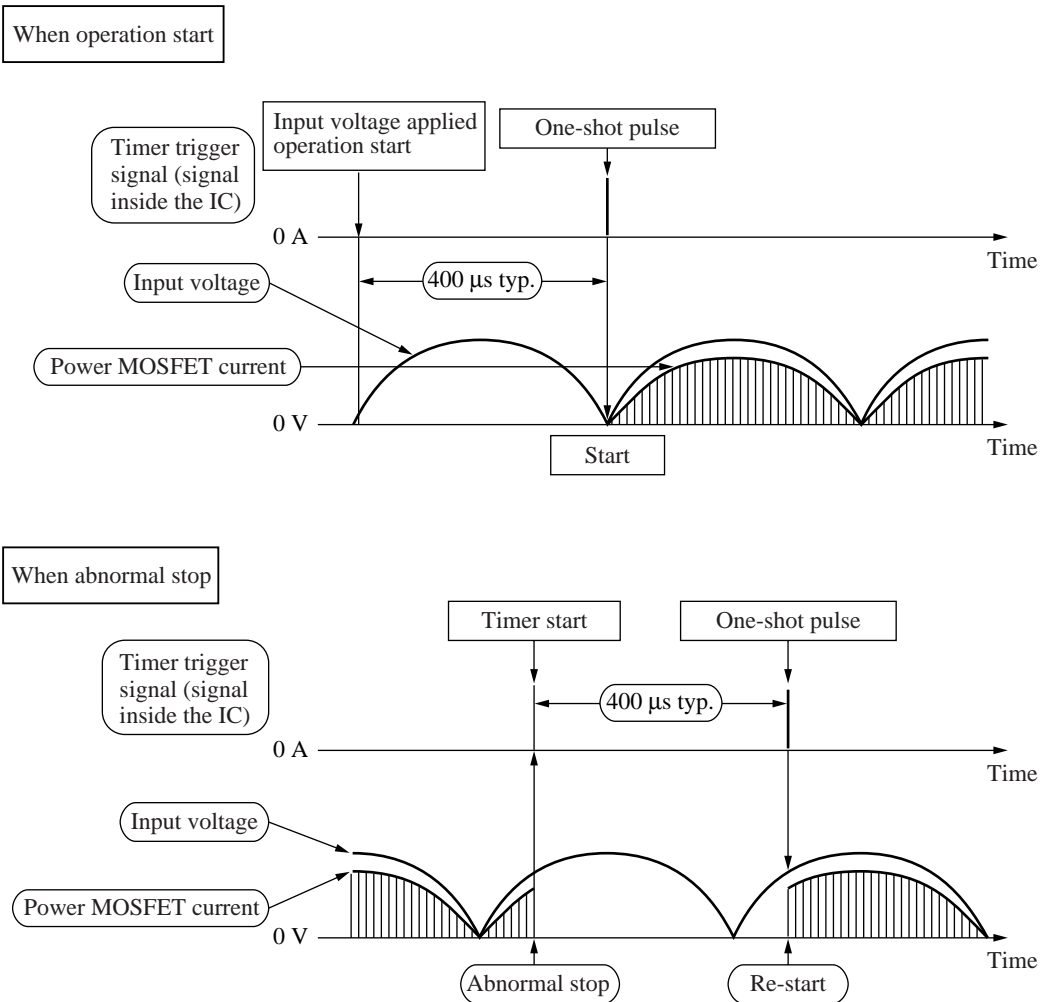

Figure 9. Explanation of timer operation

■ Application Notes (continued)

[2] Operation descriptions (continued)

2. Protection circuit (continued)

2) Overvoltage protection

(1) Cause of overvoltage

In the booster chopper circuit, control is carried out so that the input power becomes zero when the load current reaches zero. However, in the actual condition, the input power can not be decreased to zero. The output voltage is brought to out of control state, so that it rises.

The cause of the out-of-control condition is that there is a delay time from the turn-on to the turn-off of the switching device, so that the control to stop the operation of switching device becomes impossible. (Refer to figure 10.)

In order to prevent the occurrence of such problem, the AN8032 has the built-in overvoltage protection circuit, so that the number of component to be added to the external part is drastically reduced.

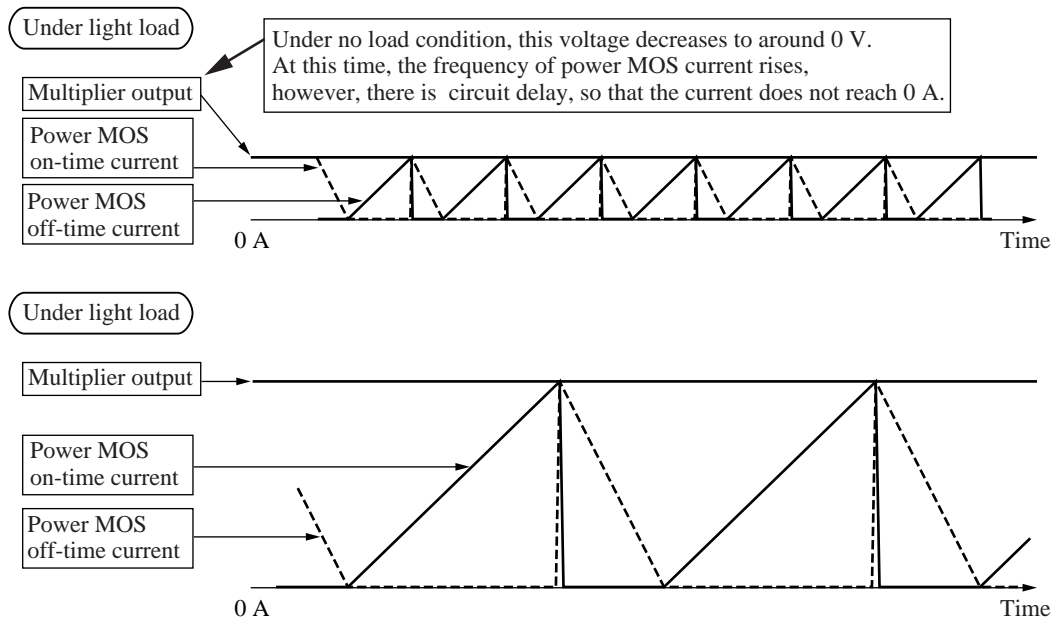
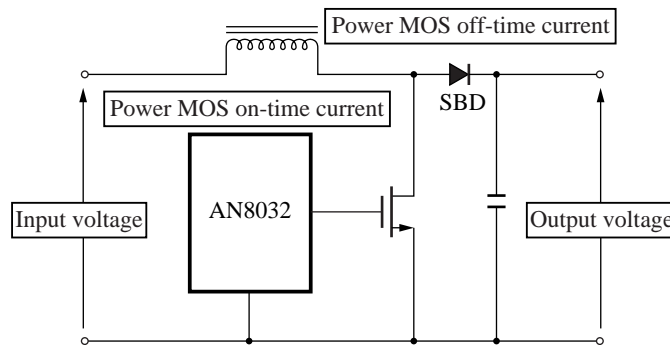

Figure 10. Explanation of operation

■ Application Notes (continued)

[2] Operation descriptions (continued)

2. Protection circuit (continued)

2) Overvoltage protection (continued)

(2) Description of overvoltage protector operation

With respect to the AN8032 IC, the input of the error amplifier which detects the output voltage is provided separately from the input of the overvoltage protection comparator. This is the point which differs from the AN8031.

Each setting is shown as follows:

- Control reference voltage of the error amplifier: 2.50 V typical
- Detection voltage of the overvoltage comparator: 2.63 V typical [Without hysteresis]

(Voltage of 5% higher than the control reference voltage of the error amplifier)

If the output voltage becomes more than 5% higher than the normal control voltage at the time of start up or abnormality occurrence, the overvoltage comparator operates to cut off the switching device.

The timer circuit is cut off when overvoltage is detected. This prevents the output voltage to increase further. Otherwise, the timer circuit will re-start the power MOSFET, and actuate it to increase the output voltage further at the time of the overvoltage detection.

Therefore, under no load condition, the output voltage of the chopper circuit is stabilized at the value which is 5% higher than the normal control voltage and does not exceed that value. (Refer to figure 11.)

The increase/decrease of the output voltage is created by the offset amount of the overvoltage comparator.

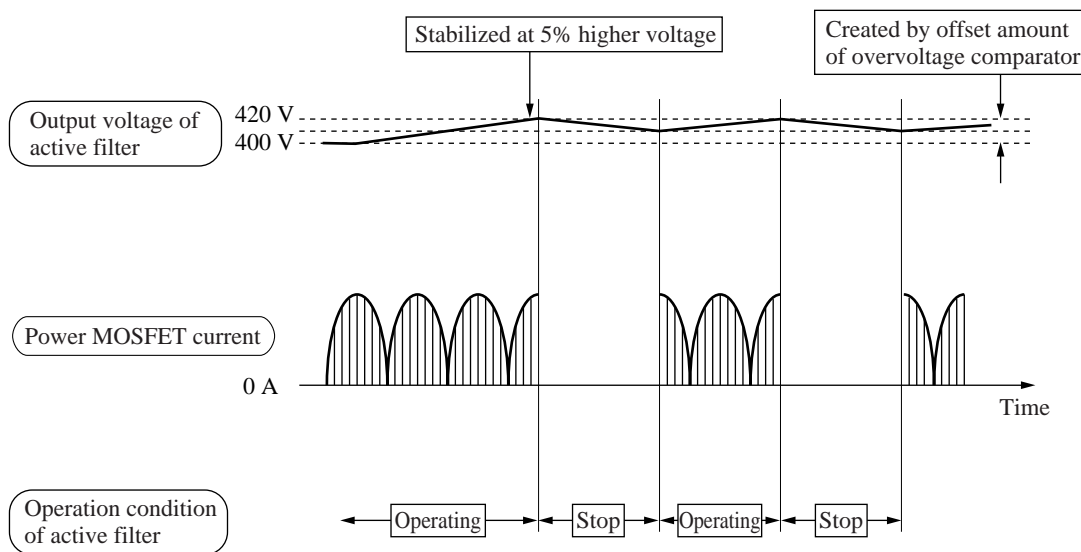

Figure 11. Protection of overvoltage protection operation

■ Application Notes (continued)

[2] Operation descriptions (continued)

2. Protection circuit (continued)

2) Overvoltage protection (continued)

(3) Output voltage overshoot at start

At operation start, the output overload condition is created because the smoothing capacitor which is connected to the output is charged. Under this condition the chopper circuit operates with full power. However, it does not immediately come out of the full-power-operation (due to control delay of the entire feedback system) even when the proper output voltage is obtained, causing the overshoot of output voltage.

The AN8032 overvoltage protector operates even at operation starts and prevents the worst cases such as damage of used parts. (Refer to figure 12.)

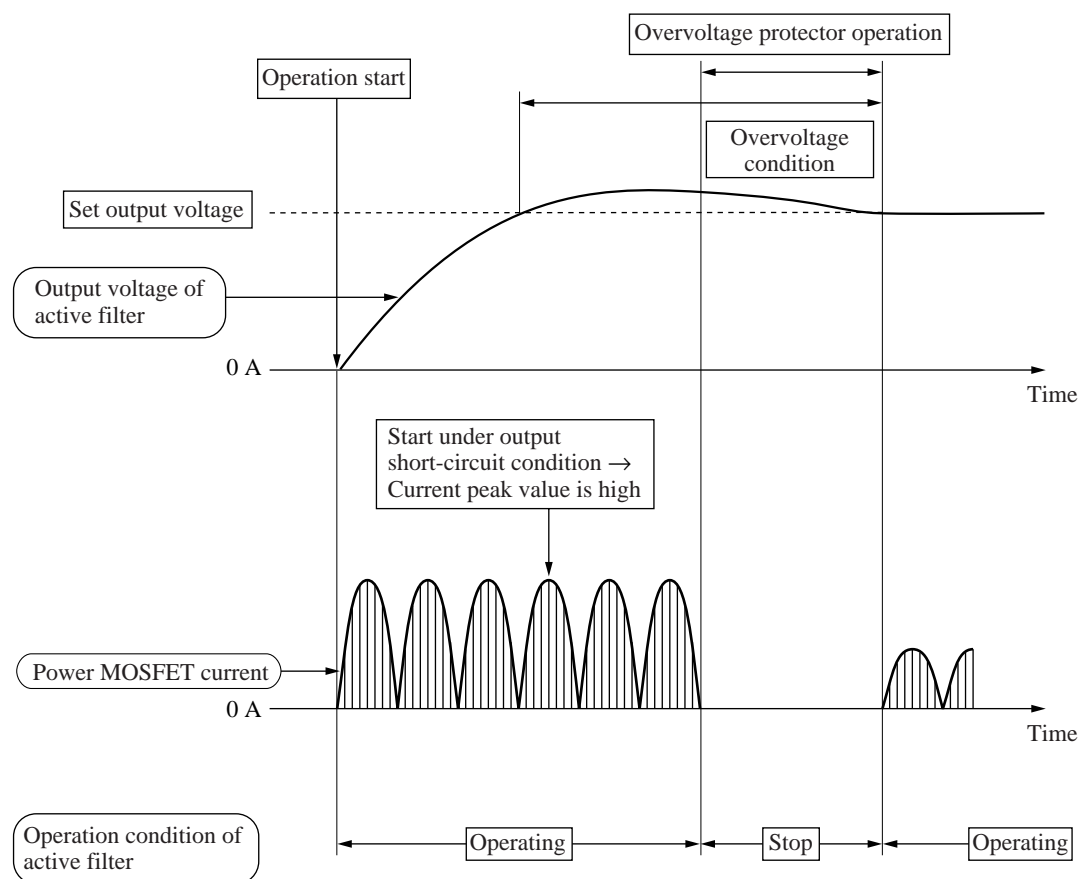

Figure 12. Output voltage overshoot when operation starts

■ Application Notes (continued)

[3] Difference between the AN8031 and the AN 8032

AN8031 → EI terminal is used in common for both the output voltage monitor function and the overvoltage detection function.

AN8032 → Exclusive-use terminal for each function (V_{CC} terminal is used in common for both PV_{CC} and V_{CC}).

EI terminal : Exclusively used for the output voltage monitor function.

OVP terminal: Exclusively used for the overvoltage detection function.

1) Reasons for change

The excessively large overvoltage, generated when the short-circuit test between the pins of the active filter output voltage monitoring resistor, can not be suppressed.

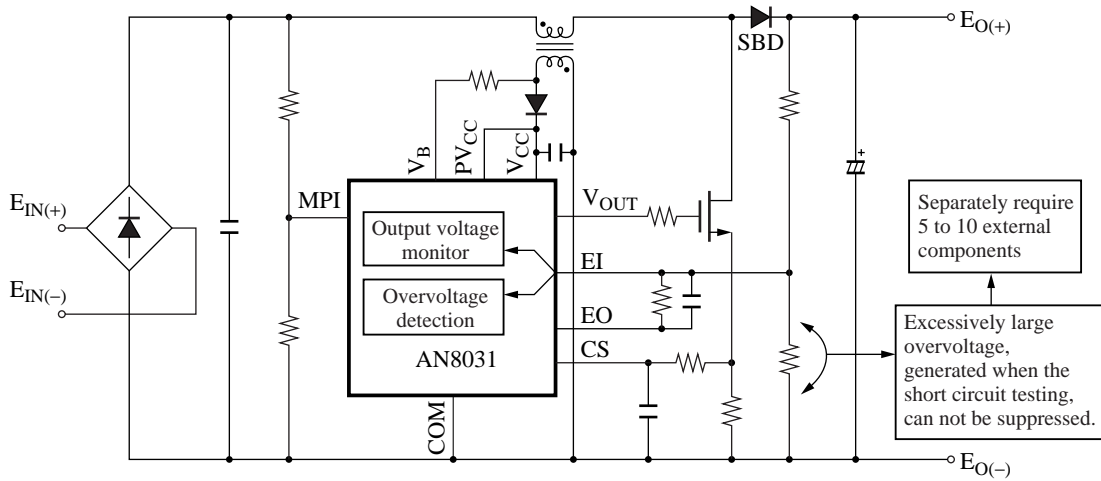

2) Countermeasures

The output voltage system and the overvoltage detection system are separated from each other.

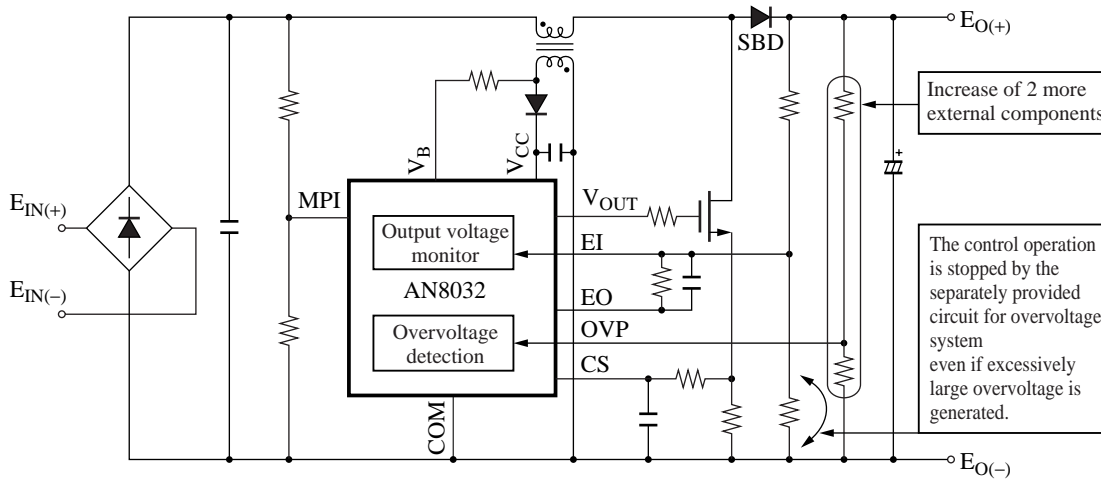

Note) The OVP terminal is arranged beside the EI terminal after taking the board pattern design into consideration.

■ Application Circuit Example

- Application circuit

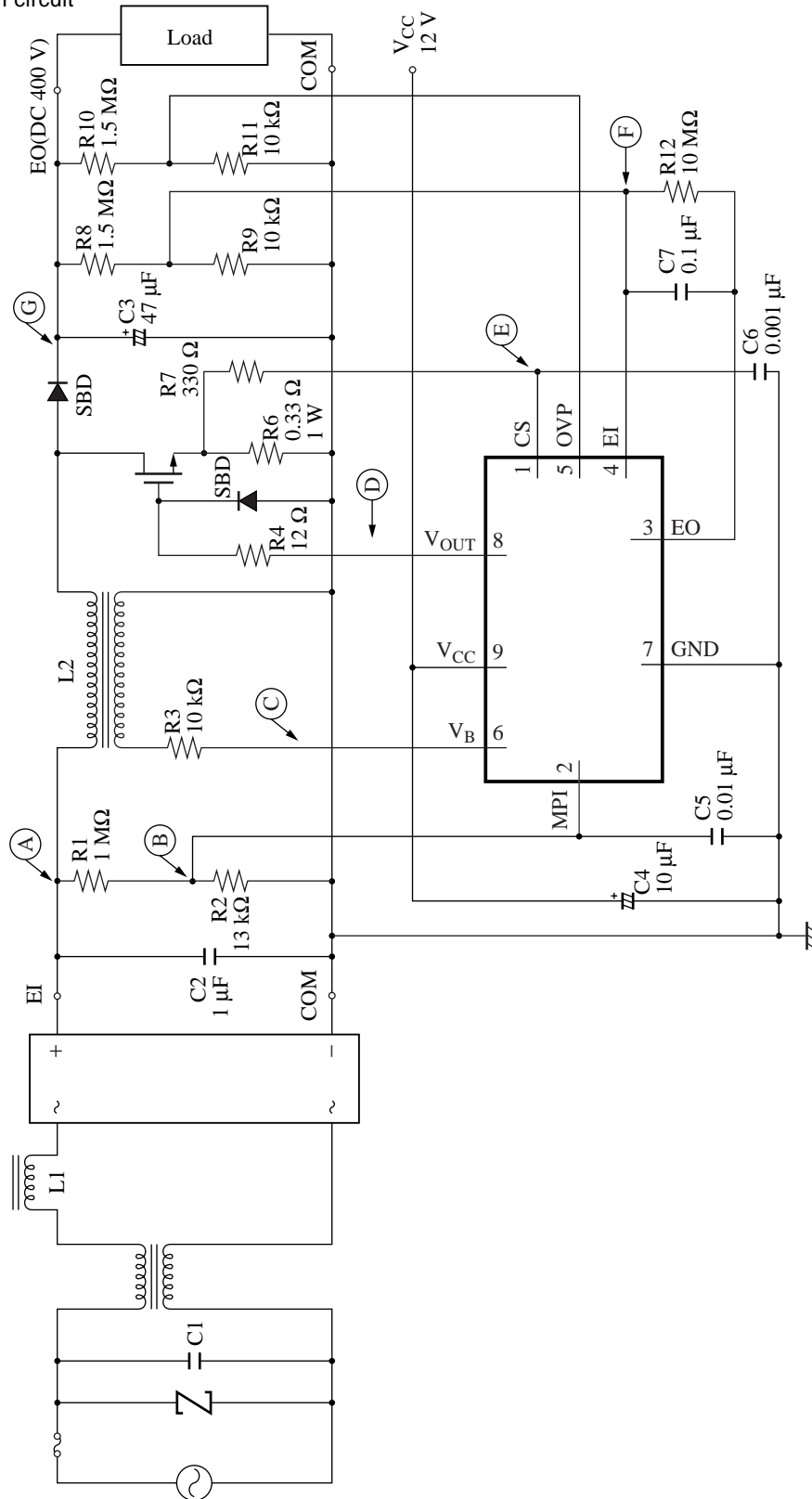

■ Application Circuit Example (continued)

- Normal operation waveforms

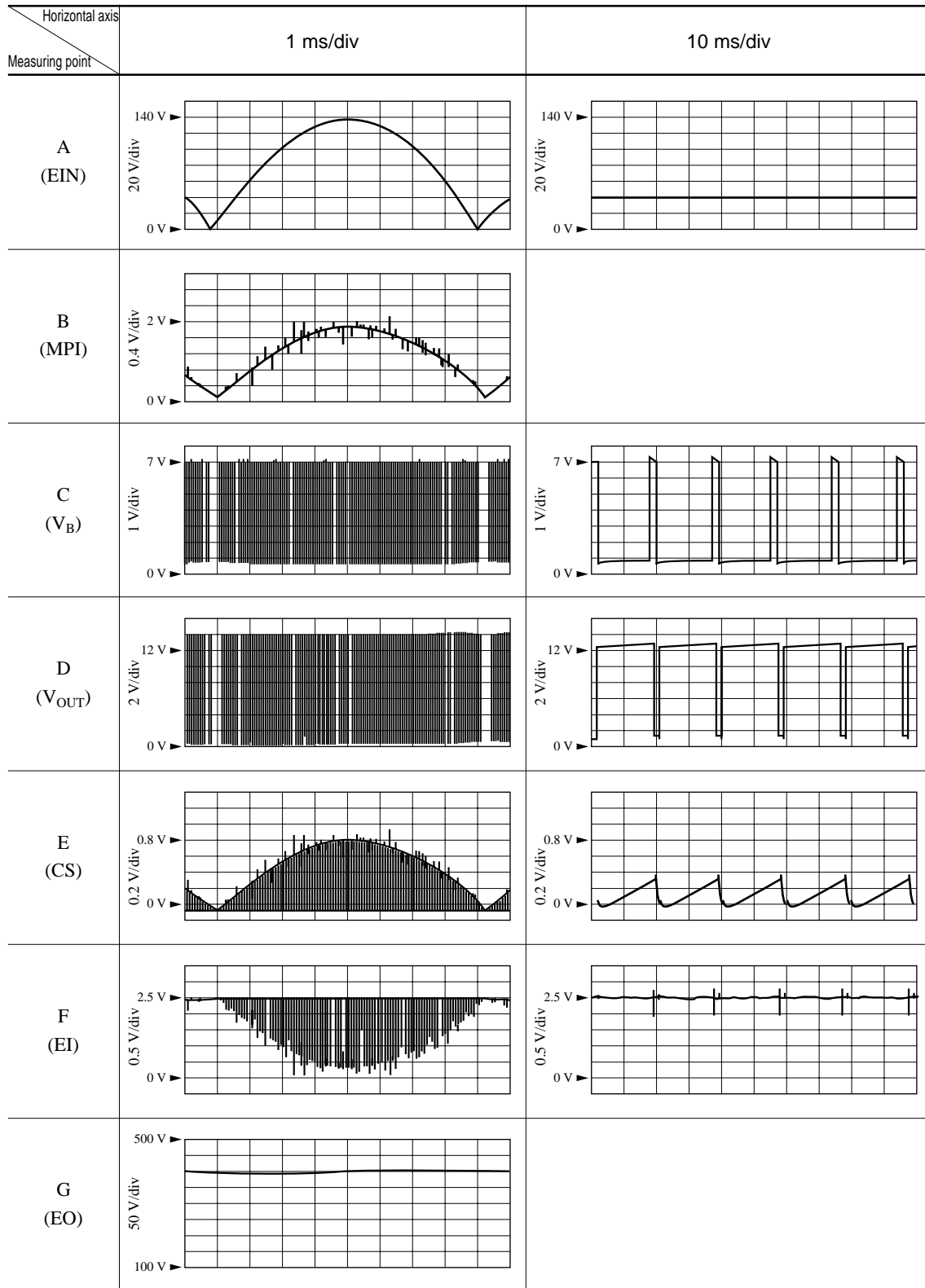

■ Application Circuit Example (continued)

• Waveforms at start

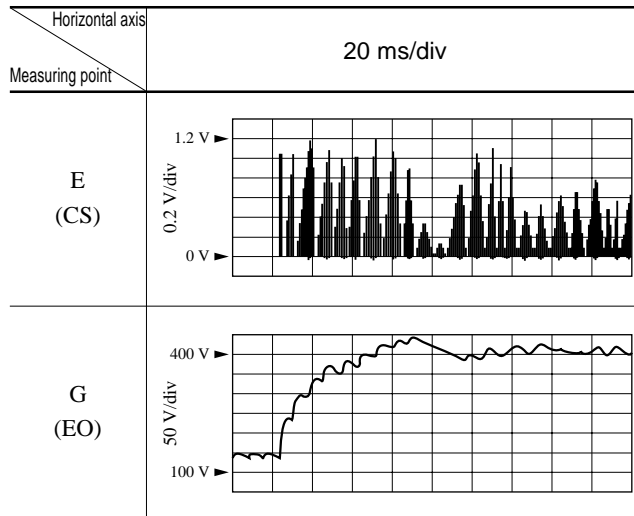

• Waveforms at stop

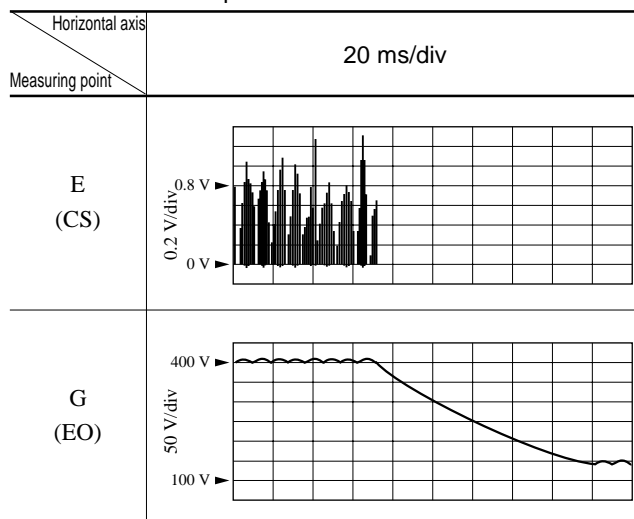

(Conditions)

- Input voltage : 100 V (AC)
- Output voltage : 400 V (DC)
- Output current : 200 mA (resistive load 2 k Ω)