

IC for Regulator+Reset Monolithic IC MM1478

September 9, 2003

Outline

This IC, developed for use in CD-ROM drives, combines a 3V regulator adapted to low power consumption with a much-sought reset function (regulator input monitoring), with internal delay circuit, set to detect 4.2V.

Features

1. Large output current 300mA max.
2. High ripple rejection rate 80dB typ.
3. Internal thermal shutdown circuit.
4. Internal current-limiting circuit.
5. Adjustment-free reset detection voltage 4.2V typ.
6. Easy to set delay time from voltage detection to reset release.

Rank table

Rnak	Regulator output voltage (V)	Detection voltage (V)
A	3.40±0.05	4.20±0.09
D	3.30±0.05	4.20±0.09
F	3.30±0.05	3.90±0.09
M	2.50±0.05	4.20±0.09

Package

SOP-8D

Applications

CD-ROM drive.

Pin Assignment

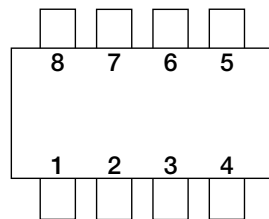

SOP-8D
(TOP VIEW)

1	N. C
2	RESET
3	CONT
4	V _{IN}
5	V _{OUT}
6	N. C
7	GND
8	Cd

Equivalent Circuit Diagram

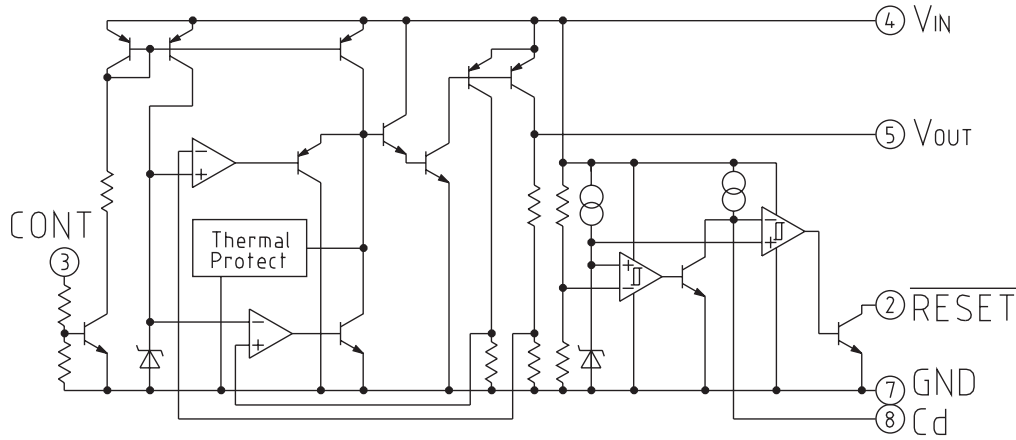

Pin Description

Pin No.	Pin name	Functions	Equivalent circuit diagram						
1	N. C								
2	RESET	Input voltage detection output Input voltage detection output pin RESET pin logic <table border="1" style="margin-left: 20px;"> <tr> <td></td> <td>RESET</td> </tr> <tr> <td>$V_{IN} < V_S$</td> <td>L</td> </tr> <tr> <td>$V_{IN} > V_S$</td> <td>H</td> </tr> </table>		RESET	$V_{IN} < V_S$	L	$V_{IN} > V_S$	H	
	RESET								
$V_{IN} < V_S$	L								
$V_{IN} > V_S$	H								
3	CONT	Output voltage on/off-control pin <table border="1" style="margin-left: 20px;"> <tr> <td>V_{CONT}</td> <td>Output</td> </tr> <tr> <td>L</td> <td>OFF</td> </tr> <tr> <td>H</td> <td>ON</td> </tr> </table> Connect cont-terminal with V_{IN} , when it is not used.	V_{CONT}	Output	L	OFF	H	ON	
V_{CONT}	Output								
L	OFF								
H	ON								
4	V_{IN}	Voltage supply input pin							
5	V_{OUT}	Regulator Output pin							
6	N. C								
7	GND	GND pin							
8	C_d	Delay time capacitor pin RESET pin output delay time can be set by the capacitance connected to the C_d pin. $t_{PLH} = 100000 \cdot C$ t_{PLH} : transmission delay time [s] C: capacitor value [F]							

Absolute Maximum Ratings

Item	Symbol	Ratings	Unit
Operating temperature	T _{OPR}	-30~+85	°C
Storage temperature	T _{STG}	-40~+125	°C
Supply voltage	V _{IN}	-0.3~+10	V
Output current	I _{OUT}	400	mA
Power dissipation	P _d	700*	mW

Note: * When mounted on a 25×40×1t mm glass epoxy board.

Recommended Operating Conditions

Item	Symbol	Ratings	Unit
Operating temperature	T _{OP}	-20~+85	°C
Output current	I _{OP}	0~300	mA
Operating voltage	V _{OP}	0~10	V

Electrical Characteristics (Typical model MM1478A) (Except where noted otherwise, T_a=25°C, V_{CONT}=1.6V) (Except where noted otherwise, resistance unit is Ω)

Item	Symbol	Measurement conditions	Min.	Typ.	Max.	Unit
No-load input current 1	I _{ccq1}	V _{IN} =5V, I _{OUT} =0mA		3	8	mA
No-load input current 2	I _{ccq2}	V _{IN} =4V, I _{OUT} =0mA		4		mA
Input current (OFF)	I _{ccq3}	V _{IN} =5V, V _{CONT} =0.4V		250		μA
Regulator						
Output Voltage	V _{OUT}	V _{IN} =5V, I _{OUT} =30mA	3.33	3.40	3.47	V
Input-Output differential Voltage	V _{i0}	V _{IN} =3.2V, I _{OUT} =150mA		0.15	0.3	V
Line regulation	ΔV ₁	V _{IN} =4.4~5.5V, I _{OUT} =30mA		10	20	mV
Load regulation	ΔV ₂	V _{IN} =5V, I _{OUT} =0~300mA		20	120	mV
V _{OUT} temperature coefficient *	ΔV _{OUT} / ΔT	T _j =-20~+80°C, V _{IN} =5V I _{OUT} =30mA		100		ppm/°C
Ripple rejection *	RR	V _{IN} =5V, f=120Hz V _{RIPPLE} =1V _{P-P} , I _{OUT} =30mA	50	80		dB
Output noise voltage *	V _n	V _{IN} =5V, f=20~80kHz I _{OUT} =30mA		40	120	μV _{rms}
CONT terminal current	I _{ON}	V _{CONT} =1.6V		5	10	μA
High threshold voltage	H		1.6		V _{IN} +0.3	V
Low threshold voltage	L		-0.3		0.4	V
Reset						
Detection voltage	V _S	V _{IN} =H→L	4.11	4.20	4.29	V
V _s temperature coefficient *	ΔV _S / ΔT	T _j =-20~+80°C		100		ppm/°C
Hysteresis voltage	ΔV _S	V _{IN} =H→L→H	100		200	mV
Low-level output voltage	V _{OL}	V _{IN} =3.9V, R _L =4.7k		100	200	mV
Output leakage current	I _{OH}	V _{IN} =5V			±0.1	μA
Output current 1	I _{oL1}	V _{IN} =3.9V, R _L =0	5			mA
Output current 2 *	I _{oL2}	V _{IN} =3.9V, R _L =0, T _a =-20~+80°C	3			mA
"H" transmission delay time *	t _{PLH}	C _d =0.0μF		30	90	μs
Reset delay time	t _{PLH1}	V _{IN} =4V→5V, C _d =0.1μF	5	10	20	ms
"L" transmission delay time *	t _{PHL}			30	90	μs
Threshold operating voltage	V _{OPL}	V _{OL} =0.4V		0.65	0.85	V

Note 1: design guaranteed

Measuring Circuit

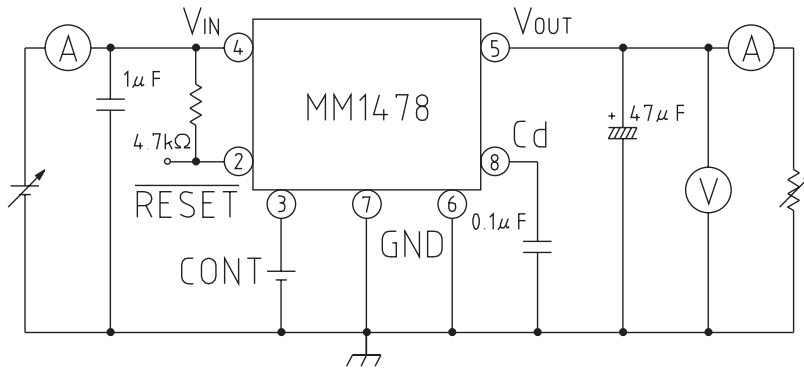

Application Circuit

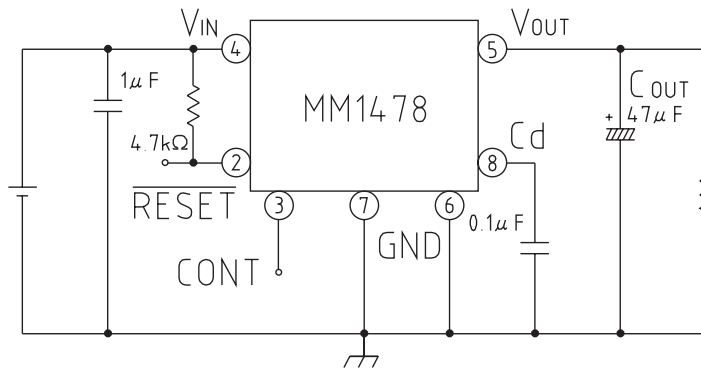

Note 1 : This regulator is not internally compensated and thus requires an external output-capacitor (C_{OUT}) for stability.

Timing Chart

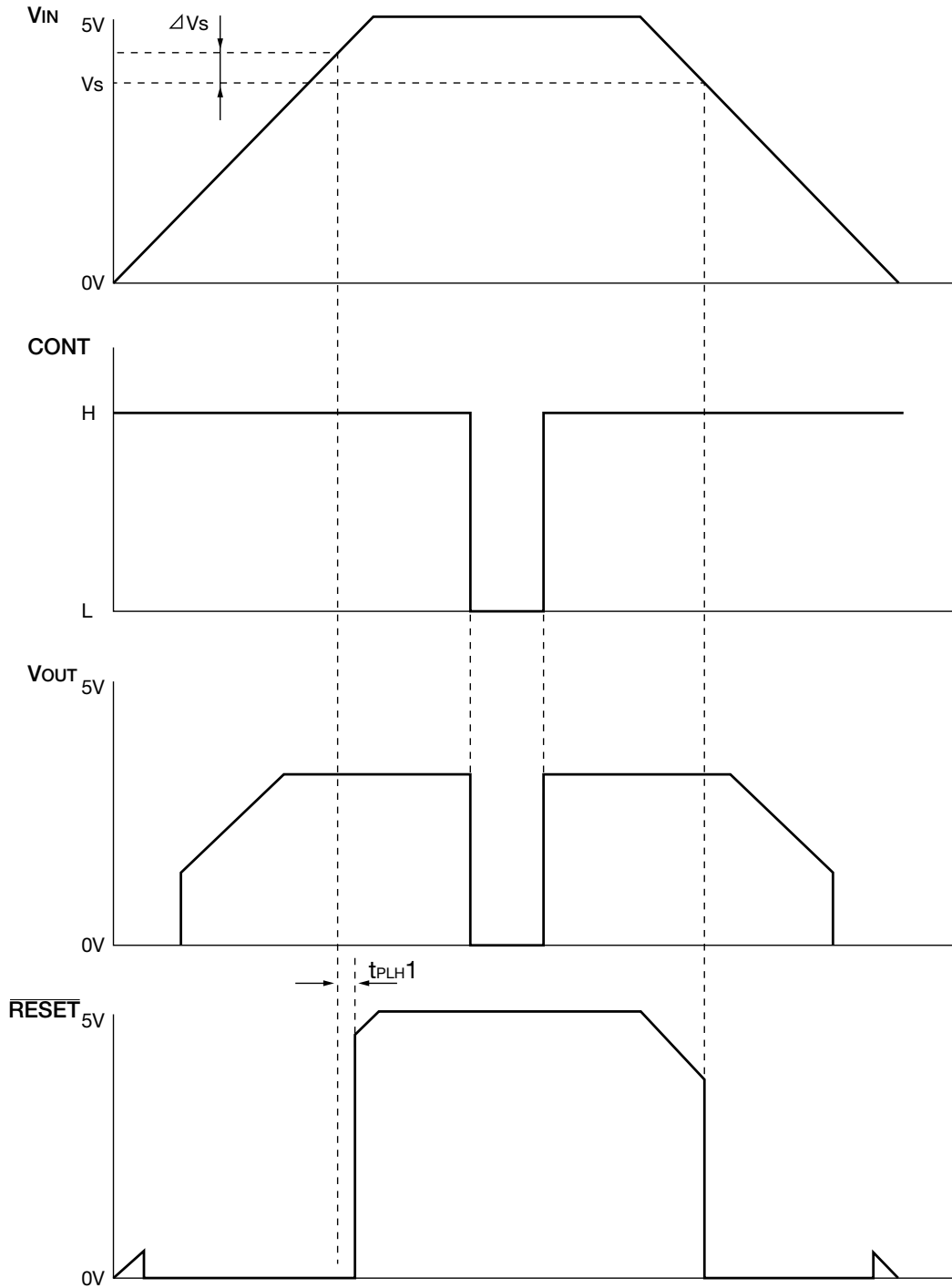

Characteristics (Typical model MM1478A)

■ Detection voltage ($I_{OUT}=0mA$)

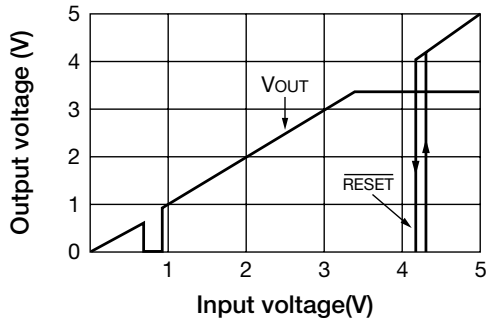

■ Output voltage vs temperature

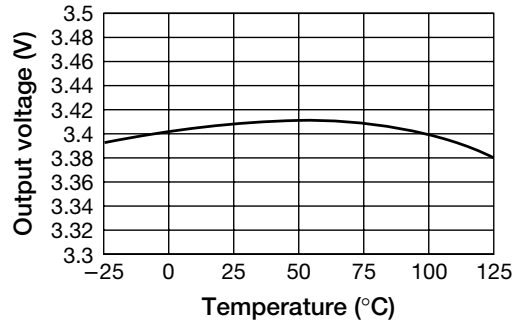

■ Line regulation

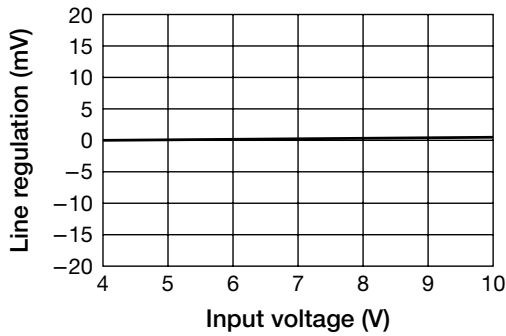

■ Load regulation

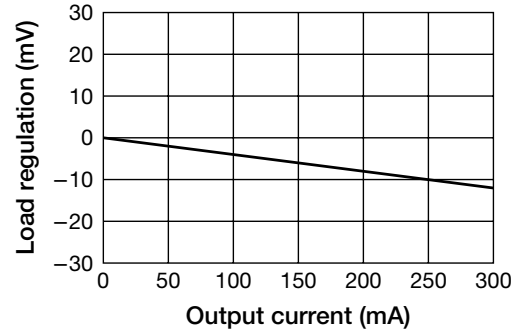

■ Ripple rejection

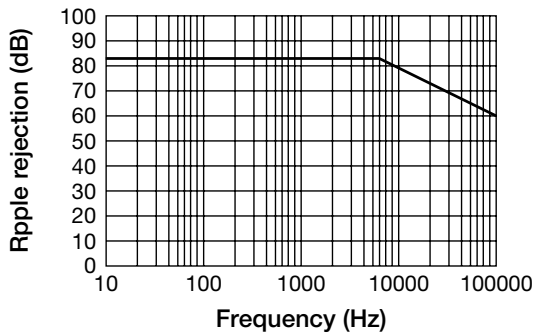

■ Detecting voltage vs temperature

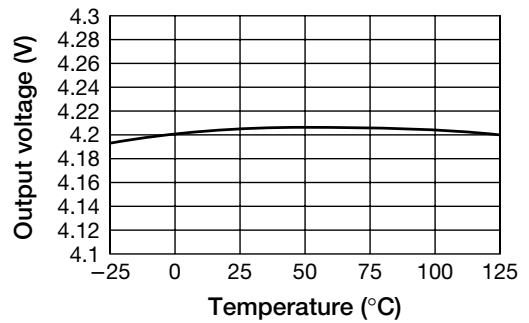

■ Allowable loss

