

Lithium-Ion Battery Charge Control Monolithic IC MM1485

Outline

This IC is a lithium-ion battery charge control IC. It is a one-chip charge control IC where the protection circuit incorporates constant-current/constant-voltage charge and precharge, and battery temperature detection functions. It was developed by eliminating the timer function from MM1475 (charge control IC) and is provided in the small package.

Features

1. Output voltage ($T_a = 0 \sim +50^\circ\text{C}$) $4.120 \pm 30\text{mV}$
2. Current consumption 1 1.5mA typ.
 Precharge function
 Adaptor (primary side) abnormality detection function
3. Battery temperature detection function

Package

TSOP-16A

Application

Lithium-ion battery charge control

Absolute Maximum Ratings ($T_a=25^\circ\text{C}$)

Item	Symbol	Ratings	Unit
Storage temperature	T_{STG}	$-40 \sim +125$	$^\circ\text{C}$
Operating temperature	T_{OPR}	$-20 \sim +70$	$^\circ\text{C}$
Power supply voltage	V_{CCMAX}	$-0.3 \sim +15$	V
Allowable loss	P_{D}	250	mW

Block Diagram

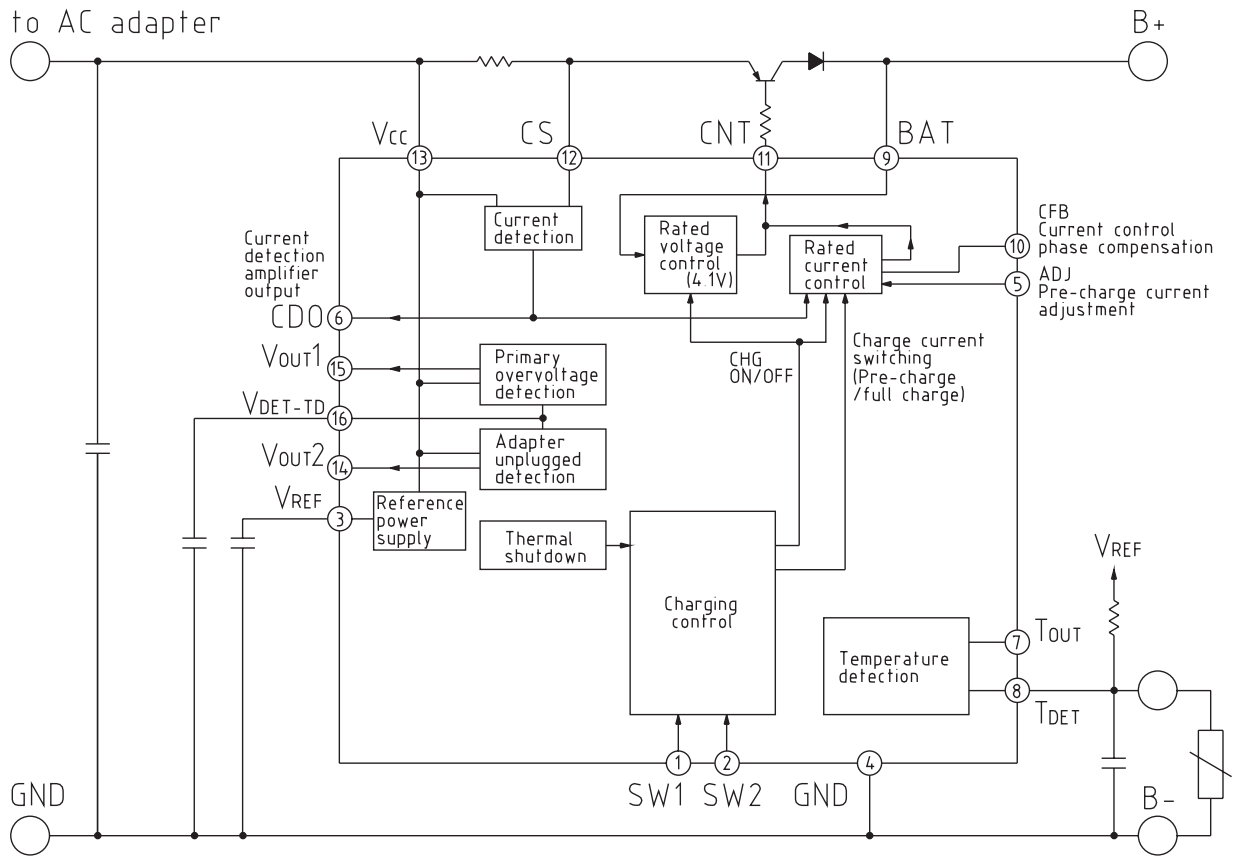

SW1 and SW2 Specifications

SW1	SW2	Charge	Current Limit
L	H	OFF	
H	H	ON	Controlled by the IC (current limit 2:25mV)
L	L	ON	Controlled by the adaptor (current limit 1:450mV)
H	L	ON	Controlled by the adaptor (current limit 1:450mV)

Pin Assignment

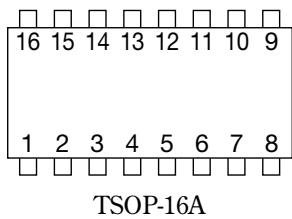



1	SW1	9	BAT
2	SW2	10	CFB
3	VREF	11	CNT
4	GND	12	CS
5	ADJ	13	Vcc
6	CDO	14	VOUT2
7	TOUT	15	VOUT1
8	TDET	16	VDET-TD

Pin Description

Pin No.	Pin Name	I/O	Function
1	SW1	Input	Charging control switching pin.
2	SW2	Input	Switches charging ON/OFF and charging current by combinations of SW1 and SW2 L and H.
3	V _{REF}	Output	Reference power supply output pin. Outputs 1.2V typ. reference voltage.
4	GND	Input	GND pin.
5	ADJ	Input	Pre-charge current adjustment pin. Pin voltage is set at 100mV typ. Pre-charge current can be adjusted by adjusting the pin voltage with an external resistor, etc. Pre-charge current is controlled by comparing the ADJ pin voltage and voltage drop value of 12dB between V _{CC} -CS.
6	C _{DO}	Output	Current detection output pin. Outputs current difference value of 18dB between V _{CC} -CS.
7	T _{OUT}	Output	Temperature detection output pin. Normal temperature: Output Tr OFF High temperature detection: Output Tr ON
8	T _{DET}	Input	Temperature detection input pin. Use external resistor and thermistor to apply resistance-divided potential from reference voltage.
9	BAT	Input	Battery voltage input pin. Detects battery voltage and controls charging.
10	CFB	Input	Constant-current control phase compensation pin. Connect an external capacitor (around 100pF) between CFB and CNT to perform phase compensation for improved oscillation.
11	CNT	Output	Charging control output pin. Controls external PNP-Tr base and performs constant-current, constant-voltage charging.
12	CS	Input	Current detection pin. Current is detected by voltage drop at external resistor between V _{CC} -CS and charging current is controlled.
13	V _{CC}	Input	Power supply input pin.
14	V _{OUT2}	Output	Adaptor unplugged detection output pin. V _{CC} low voltage input: Output Tr OFF V _{CC} recommended operating voltage: Output Tr ON
15	V _{OUT1}	Output	Overvoltage detection output pin. V _{CC} overvoltage input: Output Tr OFF V _{CC} recommended operating voltage: Output Tr ON
16	V _{DET-TD}	Input	Overvoltage detection delay time setting pin. Delay time can be set by connecting an external capacitor.

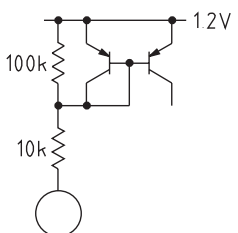
Pin Description The following valaeis typical

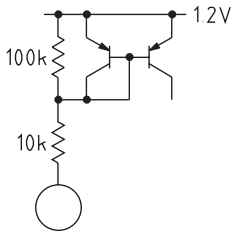
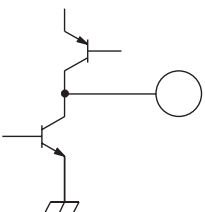
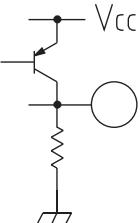
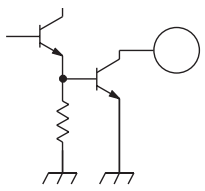
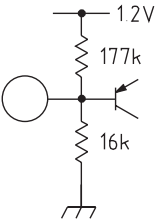
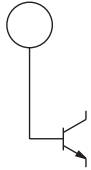
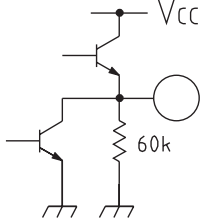
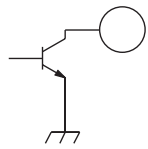
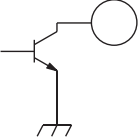
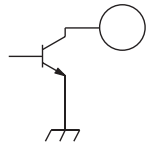
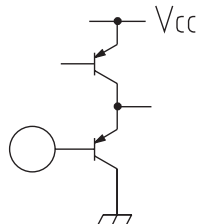
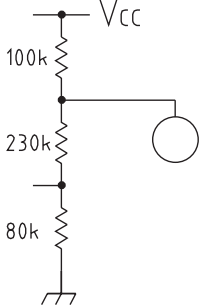
Pin No.	Pin name	Internal equivalent circuit diagram	Pin No.	Pin name	Internal equivalent circuit diagram
1	SW1		9	BAT	
2	SW2		10	CFB	
3	VREF		11	CNT	
5	ADJ		12	CS	
6	CDO		14	VOUT2	
7	TOUT		15	VOUT1	
8	TDET		16	VDET-TD	

Electrical Characteristics (Except where otherwise indicated Ta=25°C, Vcc=5V)

Item	Symbol	Conditions	Measurement pin	Min.	Typ.	Max.	Unit
Consumption current 1	ICC1	SW1, 2 : H	13		1.5	2.3	mA
Consumption current 2	ICC2	SW1, 2 : L	13		3.5	5.3	mA
Reference voltage	VREF		3		1.207		V
ADP detection voltage L	VADPL	VCC : H→L	14	2.70	2.80	2.90	V
ADP detection voltage L hysteresis voltage width	VADPLW		14	50	100	150	mV
ADP detection voltage H	VADPH	VCC : L→H	15	5.8	6.0	6.2	V
ADP detection voltage H hysteresis voltage width	VADPHW		15	50	100	150	mV
BAT pin leak current	IBAT		9			1	μA
BAT pin output voltage	VBAT	Ta=0~+50°C	9	4.090	4.120	4.150	V
CNT pin output voltage	VCNT	ICNT=20mA	11			0.5	V
SW1 pin input current	ISW1		1	40	60	80	μA
SW1 pin input voltage H	VSW1H		1	0.6		1.20	V
SW1 pin input voltage L	VSW1L		1			0.25	V
SW2 pin input current	ISW2		2	40	60	80	μA
SW2 pin input voltage H	VSW2H		2	0.6		1.20	V
SW2 pin input voltage L	VSW2L		2			0.25	V
Current limit 1	VL1	Quick charge	12,13	0.35	0.45	0.55	V
Current limit 2	VL2	Pre-charge	12,13	20	25	30	mV
Current detection amp gain	G1		6	17.5	18.0	18.5	dB
Current detection amp output offset voltage	VOFF		6	-4.5	0	4.5	mV
Current detection amp output current outflow	ICDO		6	0.5	1.0		mA
VOUT1 pin output voltage	VOUT1	IOUT1=0.12mA	15		0.2	0.4	V
VOUT2 pin output voltage	VOUT2	IOUT2=0.12mA	14		0.2	0.4	V
Battery temperature detection voltage	VTDET	VTDET : H→L	8	0.390	0.413	0.435	V
Battery temperature detection voltage hysteresis voltage width	VTDETW		8	30	60	90	mV
TOUT pin output voltage	VTOUT	ITOUT=0.12mA	7		0.2	0.4	V
TDET input bias current	IT		8		30	150	nA

* Current limits 1 and 2 are prescribed by the amount of current detection resistor voltage drop.

* Safety can not be guaranteed if this IC is damaged and control no longer is possible. Please protect with something other than this IC.

Measuring Circuit

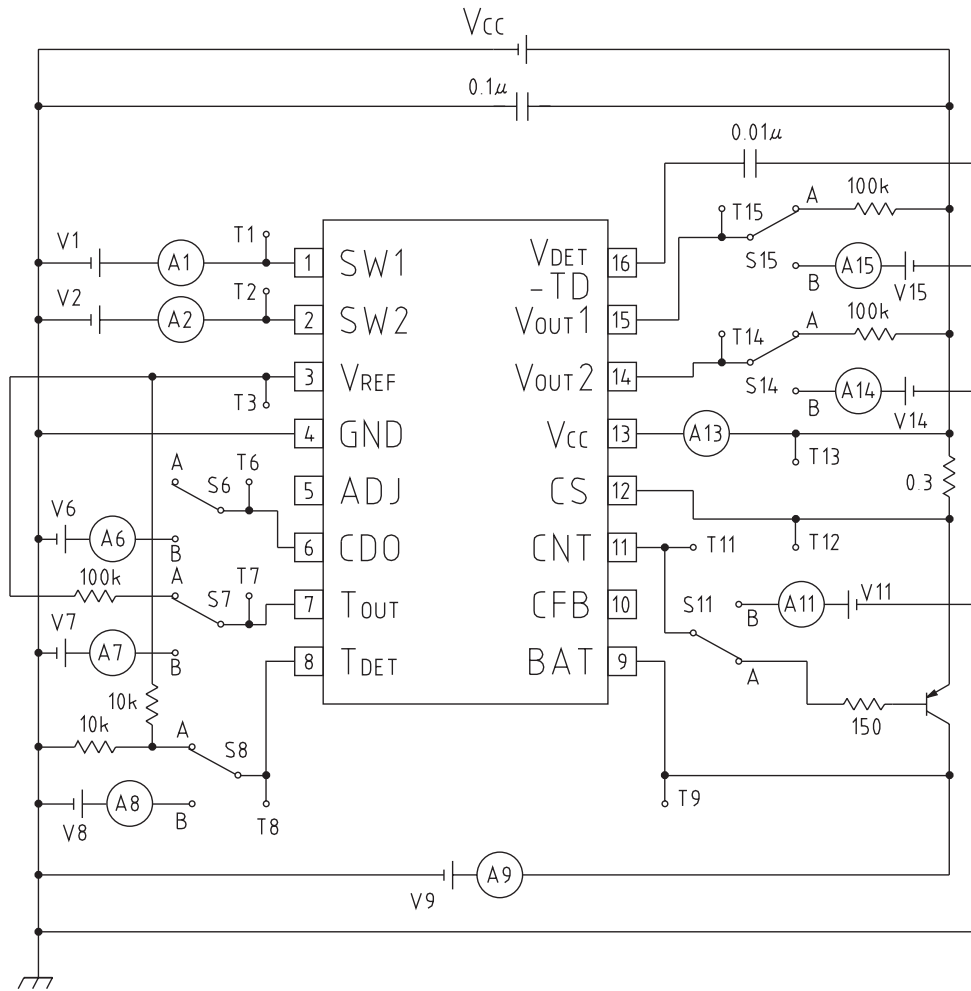

Measurement Procedures

(Except where otherwise indicated $T_a = 25^\circ\text{C}$, $V_{CC} = 5\text{V}$, V_{CC} : current limit 0.5A, $V_1 = V_2 = 0\text{V}$, $V_9 = 4.2\text{V}$, S6, 7, 8, 11, 14, 15: A)

Item	Measurement Procedure
Consumption current 1	Measure A13 current value I_{CC1} at $V_1 = V_2 = 1.2\text{V}$.
Consumption current 2	Measure A13 current value I_{CC2} .
Reference voltage	Measure T3 potential V_{REF} .
ADP detection voltage L	Gradually lower V_{CC} from 5V. V_{CC} potential is V_{ADPL} when T14 potential goes above $V_{CC} - 0.5\text{V}$.
ADP detection voltage L hysteresis voltage width	Gradually raise V_{CC} from 2V. V_{CC} potential is V_{ADPL2} when T14 potential goes under 0.5V. $V_{ADPLW} = V_{ADPL2} - V_{ADPL}$
ADP detection voltage H	Gradually raise V_{CC} from 5V. V_{CC} potential is V_{ADPH} when T15 potential goes above $V_{CC} - 0.5\text{V}$.
ADP detection voltage H hysteresis voltage width	Gradually lower V_{CC} from 7V. V_{CC} potential is V_{ADPH2} when T15 potential goes under 0.5V. $V_{ADPHW} = V_{ADPH} - V_{ADPH2}$.
BAT pin leak current	$V_{CC} = 0\text{V}$, S11: B, $V_{11} = 0\text{V}$. Measure A9 current value I_{BAT} .
BAT pin output voltage	Gradually raise V_9 from 3.5V. T9 potential is V_{BAT} when the potential difference between T13–T12 is 20mV or less.
CNT pin output voltage	$V_9 = 3.5\text{V}$, S11: B. Gradually raise V_{11} from 0V. T11 potential is V_{CNT} when A11 current value is 20mA.
SW1 pin input current	Measure A1 current value I_{SW1} .
SW1 pin input voltage H	$V_9 = 3.5\text{V}$, $V_2 = 1.2\text{V}$. Raise V_1 from 0V to 1.2V. Identify V_{SW1} H or L; when A9 is 50mA or higher, charging ON at current limit 2, and when A9 is 1mA or lower, charging is OFF.
SW1 pin input voltage L	
SW2 pin input current	Measure A2 current value I_{SW2} .
SW2 pin input voltage H	$V_9 = 3.5\text{V}$. Raise V_2 from 0V to 1.2V. Identify V_{SW2} H or L; when A9 is 450mA or higher, charging ON at current limit 1, and when A9 is 1mA or lower, charging is OFF.
SW2 pin input voltage L	
Current limit 1	$V_9 = 3.5\text{V}$. Gradually raise V_{CC} current limit value and measure the potential difference between T13–T12, V_{L1} .
Current limit 2	$V_9 = 2.5\text{V}$, $V_1 = V_2 = 1.2\text{V}$. Potential difference between T13–T12 is V_{L2} .
Current detection amp gain	$V_9 = 3.5\text{V}$. The potential difference fluctuation between T13–T12 when V_{CC} current limit value is changed from 100mA to 200mA is ΔV_a and the T6 potential fluctuation is ΔV_b . $G_1 = 20\log \Delta V_b / \Delta V_a $
Current detection amp output offset voltage	$V_9 = 4.0\text{V}$. T6 potential is V_{b2} when V_{CC} current limit is 100mA. $V_{OFF} = V_{b2}/8 - 30\text{mV}$
Current detection amp output current outflow	$V_9 = 3.5\text{V}$, V_{CC} current limit value is 300mA, S6: B, $V_6 = 0\text{V}$. Measure A6 current value.
V_{OUT1} pin output voltage	S15: B. Gradually raise V_{15} from 0V. T15 potential is V_{OUT1} when A15 current value is 0.12mA.
V_{OUT2} pin output voltage	S14: B. Gradually raise V_{14} from 0V. T14 potential is V_{OUT2} when A14 current value is 0.12mA.
Battery temperature detection voltage hysteresis voltage width	S8: B. Gradually lower V_8 from 0.6V. T8 potential is V_{TDET} when T7 potential is 0.3V or under.
Battery temperature detection voltage hysteresis voltage width	S8: B. Gradually raise V_8 from 0V. T8 potential is V_{TDET2} when T7 potential is 0.8V or higher. $V_{TDETW} = V_{TDET2} - V_{TDET}$.
T_{OUT} pin output voltage	S8: B, $V_8 = 0\text{V}$, S7: B. Gradually raise V_7 from 0V. T7 potential is V_{TOUT} when A7 current value is 0.12mA.
T_{DET} input bias current	S8: B, $V_8 = 0\text{V}$. Measure A8 potential value I_r .

Timing Chart

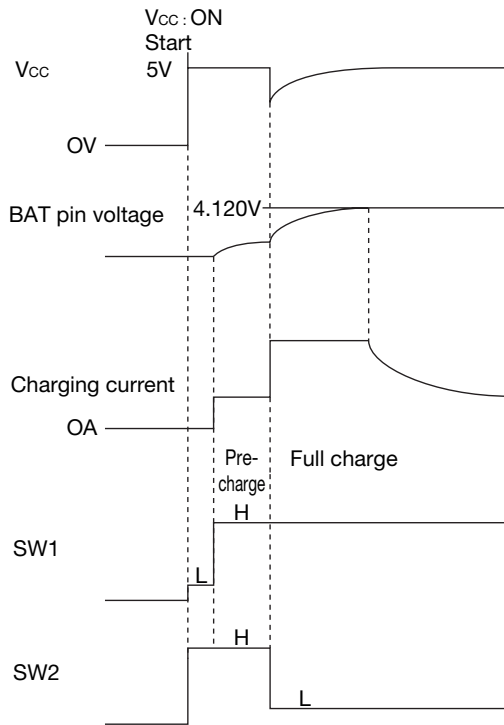

Application Circuits

