

General Description

The AOZ9004B is a battery protection IC with integrated dual common-drain N-channel MOSFET. The device includes accurate voltage detectors and delay circuits, and is suitable for protecting single-cell lithium-ion / lithium-polymer rechargeable battery packs from overcharge, over-discharge, and over-current conditions.

The AOZ9004B is available in an 8-pin TSSOP package and is rated over a -40°C to +85°C ambient temperature range.

Features

- Integrated common-drain N-channel MOSFET
- High-accuracy voltage detection circuit
 - ▶ Overcharge detection accuracy $\pm 25\text{mV}$ (+25°C), $\pm 30\text{mV}$ (-5°C to +55°C)
 - ▶ Overcharge release accuracy $\pm 50\text{mV}$
 - ▶ Over-discharge detection accuracy $\pm 50\text{mV}$
 - ▶ Over-discharge release accuracy $\pm 100\text{mV}$
 - ▶ Discharge over-current detection accuracy $\pm 15\text{mV}$
 - ▶ Load short-circuit detection accuracy $\pm 300\text{mV}$
- $\pm 20\%$ accurate internal detection delay times (external capacitors are unnecessary)
- Charger connection pin withstands up to 28V
- Wide operating temperature range -40°C to +85°C
- Low current consumption
 - ▶ 3.0mA (typ.), 5.5mA (max.) in operation mode at +25°C
- Small 8-pin TSSOP package

Applications

- Lithium-ion rechargeable battery packs
- Lithium-polymer rechargeable battery packs

Typical Application

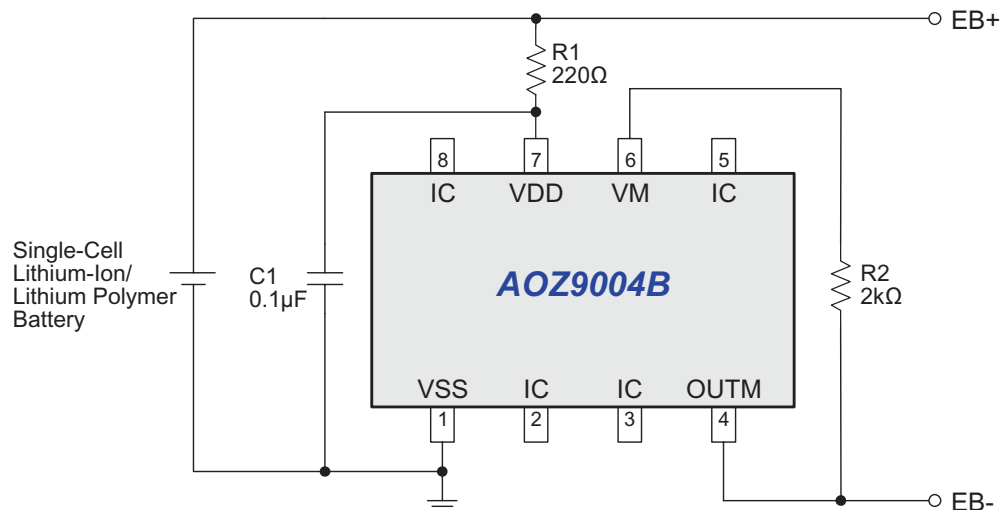

Figure 1. Typical Application

Ordering Information

Part Number	Overcharge Detection Voltage (V _{CU})	Overcharge Release Voltage (V _{CL})	Over-discharge Detection Voltage (V _{DL})	Over-discharge Release Voltage (V _{DU})	Discharge Over-current Threshold (I _{DIO})	Charge Over-current Threshold (I _{CIO})	0V Battery Charge Function	Shutdown Function
AOZ9004BI	4.250V	4.05V	2.6V	2.9V	2.4A	N/A	No	No
AOZ9004BI-01	4.275V	4.175V	2.3V	2.4V	2A	2A	Yes	Yes
AOZ9004BI-02	4.325V	4.075V	2.5V	2.9V	3A	2A	No	Yes
AOZ9004BI-03	4.280V	4.130V	2.8V	3.1V	3A	2A	No	Yes
AOZ9004BI-04	4.275V	4.075V	2.3V	2.3V	2.4A	2A	Yes	Yes

 All AOS Products are offered in packaging with Pb-free plating and compliant to RoHS standards. Please visit www.aosmd.com/web/rohs_compliant.jsp for additional information.

Table 1. Delay Time Combination⁽¹⁾

Delay Time Combination	Overcharge Detection Delay Time (t _{CU})	Over-discharge Detection Delay Time (t _{DL})	Discharge Over-current Detection Delay Time (t _{DIOV})	Charge Over-current Detection Delay Time (t _{CIOV})	Load Short-circuiting Detection Delay Time (t _{SHORT})
1 ⁽²⁾	1.2s	150ms	9ms	9ms	560μs
2 ⁽³⁾	1.2s	150ms	9ms	9ms	300μs
3	142ms	38ms	18ms	9ms	300μs
4	1.2s	150ms	18ms	9ms	300μs
5 ⁽⁴⁾	1.2s	38ms	9ms	9ms	300μs

Notes:

- The delay times can have the range specified in Table 2. Please contact our Sales department if you wish to order non-standard values and for additional information.
- Combination 1 is the default delay time combination for AOZ9004BI-02.
- Combination 2 is the default delay time combination for AOZ9004BI, AOZ9004BI-01, and AOZ9004BI-03.
- Combination 5 is the default delay time combination for AOZ9004BI-04.

Table 2. Delay Time Selection Range⁽⁵⁾

Symbol	Delay Time	Selection Range		
t _{CU}	Overcharge detection delay time	143ms	573ms	1.2s
t _{DL}	Over-discharge detection delay time	38ms	150ms	300ms
t _{DIOV}	Discharge over-current detection delay time	4.5ms	9ms	18ms
t _{CIOV}	Charge over-current detection delay time	4.5ms	9ms	18ms
t _{SHORT}	Load short-circuiting detection delay time	–	300μs	560μs

Note:

- The values in **Bold** are standard values. Please contact our Sales department if you wish to order non-standard values and for additional information.

Pin Configuration

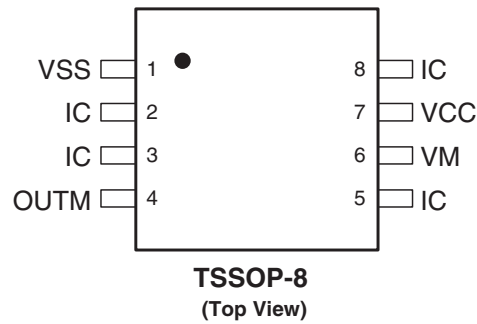

Pin Description

Pin Number	Pin Name	Pin Function
1	VSS	Ground. VSS is the source of the internal Discharge MOSFET N2 (Figure 1). Connect VSS directly to the cathode of lithium-ion/lithium polymer battery cell.
2	IC	Internally Connected Pin. This pin is for test purposes only. Always leave this pin unconnected.
3	IC	Internally Connected Pin. This pin is for test purposes only. Always leave this pin unconnected.
4	OUTM	Output Pin. OUTM is the source of the internal Charge MOSFET N1 (Figure 1). Connect OUTM directly to the negative terminal of the battery pack.
5	IC	Internally Connected Pin. This pin is for test purposes only. Always leave this pin unconnected.
6	VM	Over-current / Charger Detection Pin. Connect a 2kΩ resistor between VM and the negative terminal of the battery pack.
7	VDD	Input Supply Pin. Connect a 0.1μF capacitor between VDD and VSS.
8	IC	Internally Connected Pin. This pin is for test purposes only. Always leave this pin unconnected.

Block Diagram

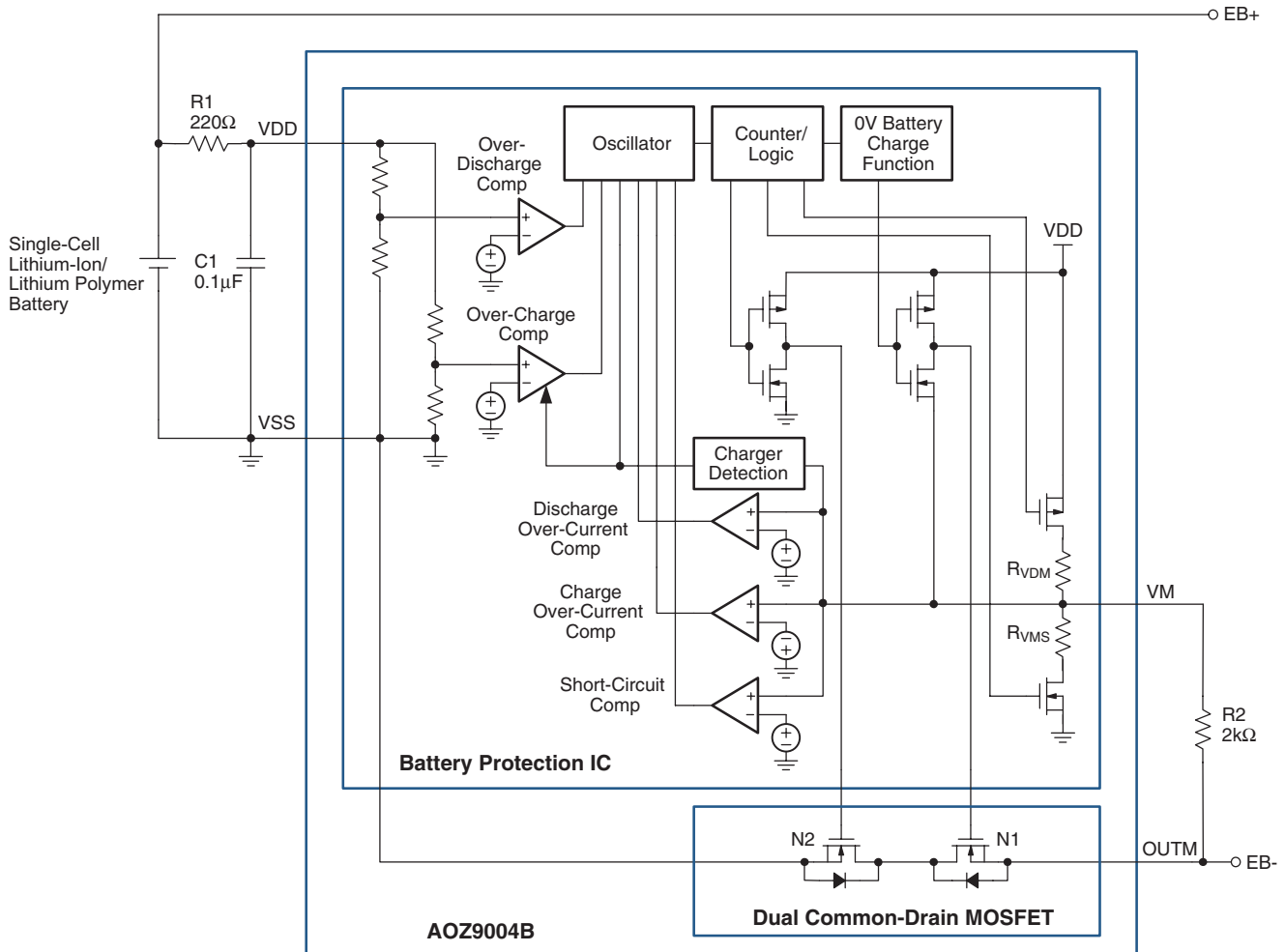

Figure 2. AOZ9004B Function Block Diagram

Absolute Maximum Ratings

Exceeding the Absolute Maximum ratings may damage the device.

Parameter	Rating
V _{DD} to V _{SS}	-0.3V to +12V
V _M to V _{DD}	-28V to +0.3V
MOSFET Gate-to-Source Voltage	-0.3V to +12V
Continuous Drain Current ⁽⁴⁾ (R _{θJA} = 95°C/W, T _A = 25°C) (R _{θJA} = 95°C/W, T _A = 85°C)	5A 3A
Pulsed Drain Current	30A
Storage Temperature (T _S)	-55°C to +125°C
Operating Temperature (T _A)	-40°C to +85°C
Power Dissipation ⁽⁶⁾ (R _{θJA} = 95°C/W, T _A = 25°C) (R _{θJA} = 95°C/W, T _A = 85°C)	1.1W 0.5W

Note:

6. The value of R_{θJA} is measured with the device mounted on 1-in² FR-4 board with 2-oz. copper, in a still air environment with T_A = 25°C. The value in any given application depends on the user's specific board design.

Electrical Characteristics

$T_A = 25^\circ\text{C}$ unless otherwise specified. Parameters specified over $T_A = -40^\circ\text{C}$ to $+85^\circ\text{C}$ are guaranteed by design only and not production tested.

Symbol	Parameter	Condition	Min.	Typ.	Max.	Unit	
DETECTION VOLTAGE							
V_{CU}	Overcharge Detection Voltage	$T_A = 25^\circ\text{C}$	$V_{CU}-0.025$	V_{CU}	$V_{CU}+0.025$	V	
		$T_A = -5^\circ\text{C}$ to $+55^\circ\text{C}$	$V_{CU}-0.03$	V_{CU}	$V_{CU}+0.03$		
		$T_A = -40^\circ\text{C}$ to $+85^\circ\text{C}$	$V_{CU}-0.060$	V_{CU}	$V_{CU}+0.040$		
V_{CL}	Overcharge Release Voltage	$V_{CL} \neq V_{CU}$	$T_A = 25^\circ\text{C}$	$V_{CL}-0.05$	V_{CL}	$V_{CL}+0.05$	V
			$T_A = -40^\circ\text{C}$ to $+85^\circ\text{C}$	$V_{CL}-0.08$	V_{CL}	$V_{CL}+0.065$	
		$V_{CL} = V_{CU}$	$T_A = 25^\circ\text{C}$	$V_{CL}-0.025$	V_{CL}	$V_{CL}+0.025$	
			$T_A = -40^\circ\text{C}$ to $+85^\circ\text{C}$	$V_{CL}-0.06$	V_{CL}	$V_{CL}+0.04$	
V_{DL}	Over-Discharge Detection Voltage (2.0 to 3.0V, Adjustable)	$T_A = 25^\circ\text{C}$	$V_{DL}-0.05$	V_{DL}	$V_{DL}+0.05$	V	
		$T_A = -40^\circ\text{C}$ to $+85^\circ\text{C}$	$V_{DL}-0.11$	V_{DL}	$V_{DL}+0.13$		
V_{DU}	Over-Discharge Release Voltage (2.0 to 3.40V, Adjustable)	$V_{DU} \neq V_{DL}$	$T_A = 25^\circ\text{C}$	$V_{DU}-0.10$	V_{DU}	$V_{DU}+0.10$	V
			$T_A = -40^\circ\text{C}$ to $+85^\circ\text{C}$	$V_{DU}-0.15$	V_{DU}	$V_{DU}+0.19$	
		$V_{DU} = V_{DL}$	$T_A = 25^\circ\text{C}$	$V_{DU}-0.05$	V_{DU}	$V_{DU}+0.05$	
			$T_A = -40^\circ\text{C}$ to $+85^\circ\text{C}$	$V_{DU}-0.11$	V_{DU}	$V_{DU}+0.13$	
V_{DIOV}	Discharge Over-Current Threshold	$T_A = 25^\circ\text{C}$	$V_{DIOV}-0.015$	V_{DIOV}	$V_{DIOV}+0.015$	V	
		$T_A = -40^\circ\text{C}$ to $+85^\circ\text{C}$	$V_{DIOV}-0.021$	V_{DIOV}	$V_{DIOV}+0.024$		
V_{SHORT}	Load Short-Circuiting Detection Voltage	AOZ9004BI, $T_A = 25^\circ\text{C}$	0.9	1.2	1.5	V	
		AOZ9004BI, $T_A = -40^\circ\text{C}$ to $+85^\circ\text{C}$	0.7	1.2	1.7		
		AOZ9004BI-01/02/03/04, $T_A = 25^\circ\text{C}$	0.35	0.50	0.65		
		AOZ9004BI-01/02/03/04, $T_A = -40^\circ\text{C}$ to $+85^\circ\text{C}$	0.3	0.5	0.7		
V_{CIOV}	Charge Over-Current Threshold	$T_A = 25^\circ\text{C}$	-0.13	-0.1	-0.07	V	
		$T_A = -40^\circ\text{C}$ to $+85^\circ\text{C}$	-0.14	-0.1	-0.06		
0V BATTERY CHARGE FUNCTION							
V_{0INH}	0V Battery Charge Inhibition Battery Voltage (0V battery charging function "unavailable")	$T_A = 25^\circ\text{C}$			0.5	V	
		$T_A = -40^\circ\text{C}$ to $+85^\circ\text{C}$			0.3		
V_{0CHA}	0V Battery Charge Starter Battery Voltage (0V battery charging function "available")	$T_A = 25^\circ\text{C}$	1.2			V	
		$T_A = -40^\circ\text{C}$ to $+85^\circ\text{C}$	1.7				
INPUT VOLTAGE							
V_{DSOP1}	Operating Voltage Between VDD Pin and VSS Pin	Internal Circuit Operating Voltage	1.5		8	V	
V_{DSOP2}	Operating Voltage Between VDD Pin and VM Pin	Internal Circuit Operating Voltage	1.5		28	V	
INPUT CURRENT (No Shutdown Function)							
I_{OPE}	Current Consumption During Operation	$V_{DD} = 3.5\text{V}, V_{VM} = 0\text{V}$	1.0	3.0	5.5	μA	
		$T_A = -40^\circ\text{C}$ to $+85^\circ\text{C}$	0.7	3.0	6.0		
I_{OPED}	Current Consumption During Over-Discharge	$V_{DD} = V_{VM} = 1.5\text{V}$	0.3	2.0	3.5	μA	
		$T_A = -40^\circ\text{C}$ to $+85^\circ\text{C}$	0.2	2.0	3.8		
INPUT CURRENT (Shutdown Function)							
I_{OPE}	Current Consumption During Operation	$V_{DD} = 3.5\text{V}, V_{VM} = 0\text{V}$	1.0	3.0	5.5	μA	
		$T_A = -40^\circ\text{C}$ to $+85^\circ\text{C}$	0.7	3.0	6.0		
I_{PDN}	Current Consumption at Shutdown	$V_{DD} = V_{VM} = 1.5\text{V}$			0.2	μA	
		$T_A = -40^\circ\text{C}$ to $+85^\circ\text{C}$			0.3		

Electrical Characteristics (Continued)

$T_A = 25^\circ\text{C}$ unless otherwise specified. Parameters specified over $T_A = -40^\circ\text{C}$ to $+85^\circ\text{C}$ are guaranteed by design only and not production tested.

Symbol	Parameter	Condition	Min.	Typ.	Max.	Unit
INTEGRATED MOSFET						
BV_{DS_C}	Charge Control MOSFET Drain-Source Breakdown Voltage	$V_{DD} = V_{CU}$	30			V
I_{LEAK_C}	Charge Control MOSFET Leakage Current	$V_{DD} = V_{CU}$			1	μA
BV_{DS_D}	Discharge Control MOSFET Drain-Source Breakdown Voltage	$V_{DD} = V_{DL}$	30			V
I_{LEAK_D}	Discharge Control MOSFET Leakage Current	$V_{DD} = V_{DL}$			1	μA
R_{SS}	Total Output Resistance (OUTM to VSS)	$V_{DD} = 3.5\text{V}, I_{OUT} = 1.5\text{A}$		40	48	$\text{m}\Omega$
DETECTION DELAY TIME (Combination 2 per Table 1)						
t_{CU}	Overcharge Detection Delay Time	$T_A = 25^\circ\text{C}$	0.96	1.2	1.4	s
		$T_A = -40^\circ\text{C}$ to $+85^\circ\text{C}$	0.7	1.2	2	
t_{DL}	Over-Discharge Detection Delay Time	$T_A = 25^\circ\text{C}$	120	150	180	ms
		$T_A = -40^\circ\text{C}$ to $+85^\circ\text{C}$	83	150	255	
t_{DIOV}	Discharge Over-Current Detection Delay Time	$T_A = 25^\circ\text{C}$	7.2	9	11	ms
		$T_A = -40^\circ\text{C}$ to $+85^\circ\text{C}$	5	9	15	
t_{CIOV}	Charge Over-Current Detection Delay Time	$T_A = 25^\circ\text{C}$	7.2	9	11	ms
		$T_A = -40^\circ\text{C}$ to $+85^\circ\text{C}$	5	9	15	
t_{SHORT}	Load Short-Circuiting Detection Delay Time	$T_A = 25^\circ\text{C}$	240	300	360	μs
		$T_A = -40^\circ\text{C}$ to $+85^\circ\text{C}$	150	300	540	

Typical Performance Characteristics

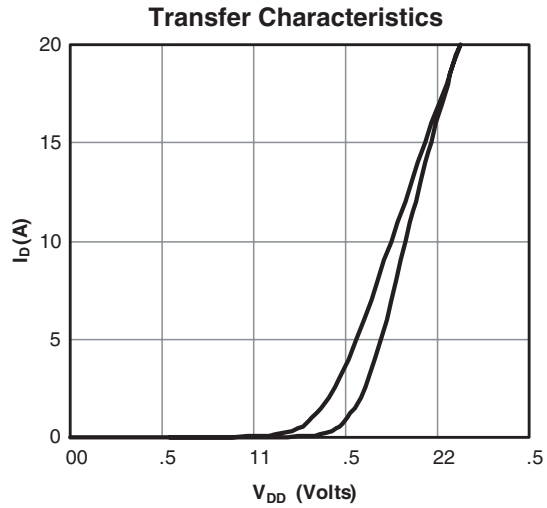
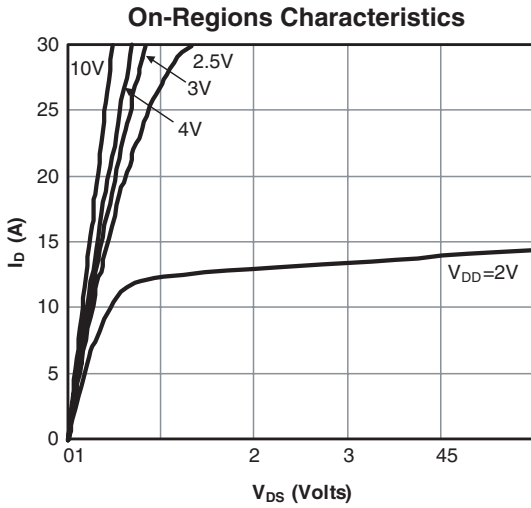

On-Resistance vs. Drain Current and Gate Voltage

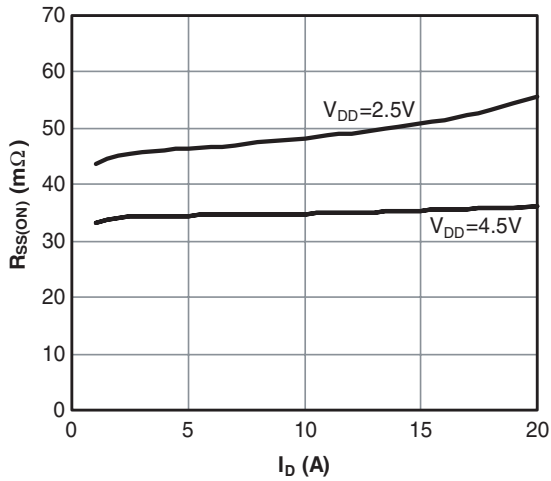

On-Resistance vs. Junction Temperature

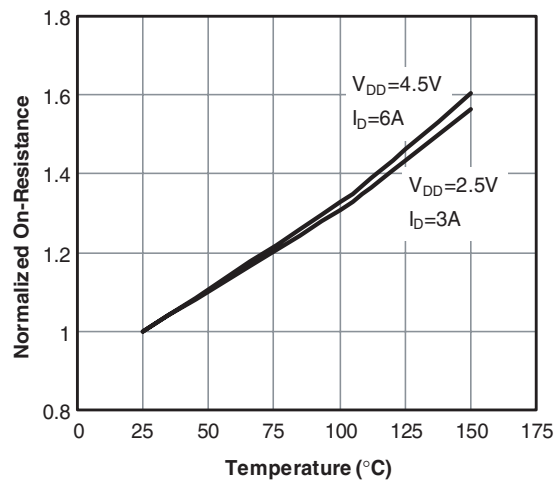

On-Resistance vs. Gate-Source Voltage

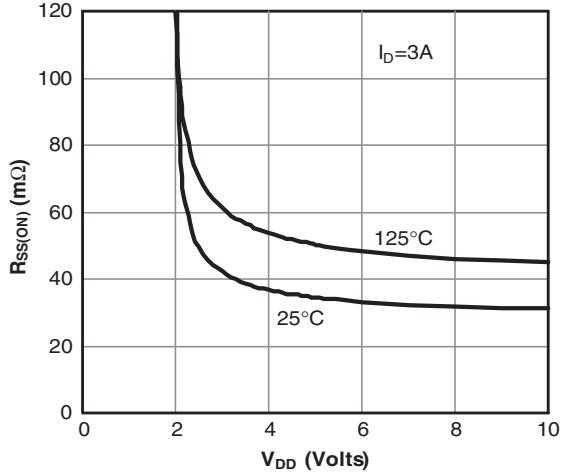

Body-Diode Characteristics

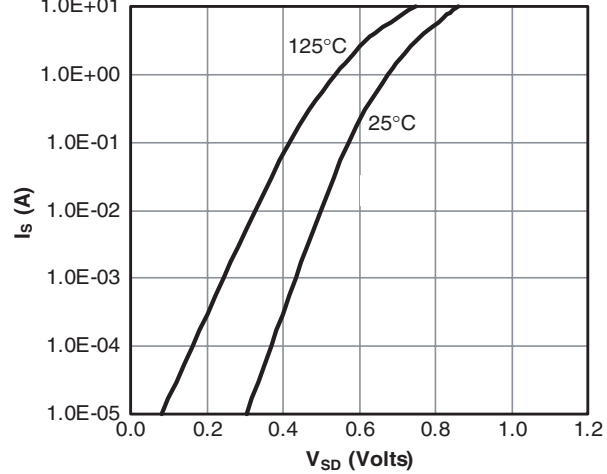

Theory of Operation

Please refer to the Timing Diagrams for more information.

Normal Status

The AOZ9004B monitors the voltage between the VDD pin and VSS pin and the voltage difference between the VM pin and VSS pin to control charging and discharging. Since the device only draws a few microamperes of current during operation and the voltage drop across the low-pass filter R1 is negligible, the voltage between VDD and VSS is equal to the battery voltage. When the battery voltage is in the range between over-discharge detection voltage (V_{DL}) and overcharge detection voltage (V_{CU}), and the VM pin voltage is in the range between the charge over-current detection voltage (V_{CIOV}) and discharge over-current detection voltage (V_{DIOV}), the IC turns both the charging and discharging control FETs on. In this normal status, charging and discharging can be carried out freely.

Caution: Products with “Shut-down Function Available” feature may not enable discharging when the battery is connected for the first time. Connect the charger or short VM pin to VSS can restore the normal status.

Overcharge Status

When the battery voltage rises higher than overcharge detection voltage (V_{CU}) for the overcharge detection delay time (t_{CU}) or longer in the normal status, the AOZ9004B turns off the charging control MOSFET to stop charging. This condition is the overcharge status. The resistance (R_{VMD}) between the VM pin and VDD pin, and the resistance (R_{VMS}) between the VM pin and VSS pin are not connected. The overcharge status is released in the following two cases:

1. When the battery voltage falls below overcharge release voltage (V_{CL}) and VM pin voltage is higher than -0.7V (Typ.) (charger is removed), the AOZ9004B turns on the charging control MOSFET and returns to the normal status.
2. When a load is connected and battery voltage is below overcharge detection voltage (V_{CU}), the AOZ9004B turns on the charging control MOSFET and returns to the normal status.

Caution: When both charger and load are connected after overcharge detection, charging control FET still remains off and a portion of the load current may flow through body diode of charging control FET if the charger can not supply the full load current. This condition may overheat the charging control FET. Please refer to the Typical Characteristics for more information.

Over-Discharge Status

When the battery voltage falls below over-discharge detection voltage (V_{DL}) for the over-discharge detection delay time (t_{DL}) or longer, the IC turns off the discharging control MOSFET to stop discharging. This condition is the over-discharge status. Under the over-discharge status, the VM pin voltage is pulled up by the resistor between the VM pin and VDD pin in the IC (R_{VMD}). The resistance (R_{VMS}) between the VM pin and VSS pin is not connected in the over-discharge status. When voltage difference between the VM pin and VDD pin is 1.3V (Typ.) or lower, the productions with “Shut-down Function Available” feature can enter the shut-down status to save power. At this status, the current consumption is reduced to the shut-down current consumption (IPON). The shut-down status is released when a charger is connected and the voltage difference between the VM pin and VDD pin becomes 1.3V (Typ.) or higher.

When a battery in the over-discharge status is connected to a charger and provides that the VM pin voltage is lower than -0.7V (Typ.), the AOZ9004B releases the over-discharge status and turns on the discharging MOSFET when the battery voltage reaches over-discharge detection voltage (V_{DL}) or higher. If VM pin voltage is not lower than -0.7V (Typ.), the AOZ9004B releases the over-discharge status and turns on the discharging MOSFET when the battery voltage reaches over-discharge detection voltage (V_{DU}) or higher.

Discharge Over-Current Status (Discharge Over-current, Load Short-circuiting)

When a battery is in the normal status, and the discharge current becomes higher than specified value and the status lasts for the discharge over-current detection delay time (t_{DIOV}), the IC turns off the discharge control MOSFET and stops discharging. This status is the discharge over-current status. In the discharge over-current status, the VM pin and VSS pin are shorted by the resistor between VM pin and VSS pin (R_{VMS}) in the IC. When the load is disconnected, the VM pin returns to the VSS potential. When the impedance between the EB+ pin and EB- pin (Refer to Figure 1) increases and is equal to the impedance that enables automatic restoration and the voltage at the VM pin returns to discharge over-current detection voltage (V_{DIOV}) or lower, the discharge over-current status is restored to the normal status. Even if the connected impedance is smaller than automatic restoration level, the AOZ9004B will be restored to the normal status from discharge over-current detection status when the voltage at the VM pin becomes the discharge over-current detection voltage (V_{DIOV}) or lower

by connecting the charger. The resistance (R_{VMD}) between the VM pin and VDD pin is not connected in the discharge over-current detection status.

When a battery is in the normal status, and the discharge current becomes abnormally higher (EB+ pin and EB- pin shorted), and thus the VM pin voltage is equal or higher than load short-circuiting detection voltage (V_{SHORT}) for load short-circuiting detection delay time (t_{SHORT}), the IC turns off the discharge control MOSFET and stops discharging. This status is the load shorting-circuiting status. In the load shorting-circuiting status, the VM pin and VSS pin are shorted by the resistor between VM pin and VSS pin (R_{VMS}) in the IC. When the short-circuiting condition is released, the VM pin returns to the VSS potential. The resistance (R_{VMD}) between the VM pin and VDD pin is not connected in the load shorting-circuiting status.

Charge Over-Current Status

When a battery in the normal status is in the status, and the charge current is higher than the specified value and the status lasts for the charge over-current detection delay time (t_{CIOV}), the charge control MOSFET is turned off and charging is stopped. This status is the charge over-current status. This IC will be restored to the normal status from the charge over-current status when, the voltage at the VM pin returns to charge over-current detection voltage (V_{CIOV}) or higher by removing the charger. The charge over-current detection function does not work in the over-discharge status. The resistance (R_{VMD}) between the VM pin and VDD pin, and the resistance (R_{VMS}) between the VM pin and VSS pin are not connected in the charge over-current status.

0V Battery Charging Function “Available”

This function is used to recharge a connected battery whose voltage is 0V due to self-discharge. When the 0V battery charge starting charger voltage (V_{0CHA}) or a higher voltage is applied between the EB+ and EB- pins by connecting a charger, the charging control MOSFET gate is fixed to the VDD pin voltage.

When the voltage between the gate and source of the charging control MOSFET becomes equal to or higher than the turn-on voltage due to the charger voltage, the charging control MOSFET is turned on to start charging. At this time, the discharging control MOSFET is off and the charging current flows through the internal parasitic diode in the discharging control MOSFET. When the battery voltage becomes equal to or higher than over-discharge release voltage (V_{DU}), the AOZ9004B enters the normal status.

Battery Charging Function “Unavailable”

This function inhibits recharging when a battery that is internally short-circuited (0V battery) is connected. When the battery voltage is the 0V battery charge inhibition battery voltage (V_{0INH}) or lower, the charging control MOSFET gate is fixed to the EB- pin voltage to inhibit charging. When the battery voltage is the 0V battery charge inhibition battery voltage (V_{0INH}) or higher, charging can be performed.

Timing Diagrams

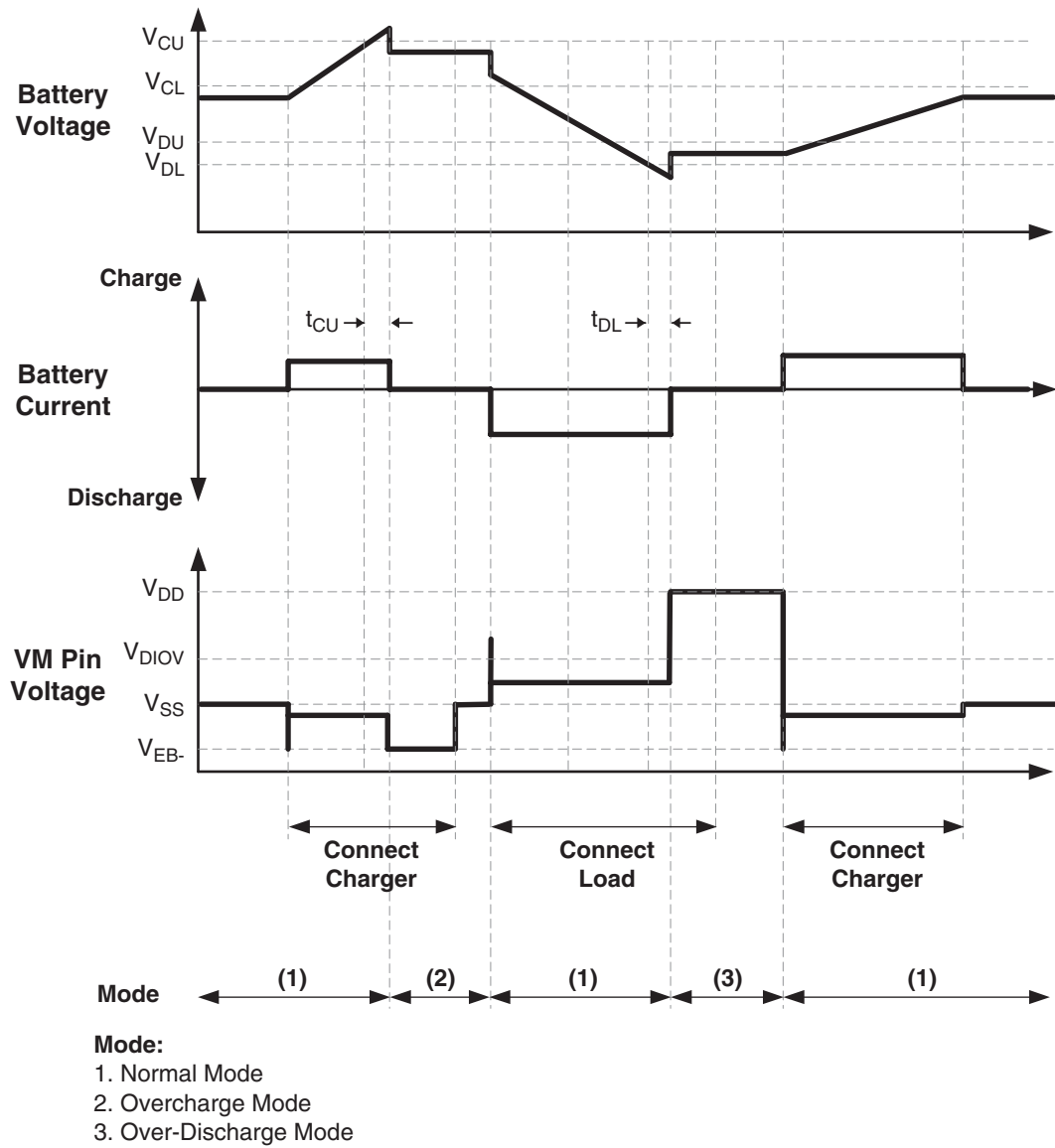

Figure 3. Overcharge and Over-discharge Detection Timing Diagram

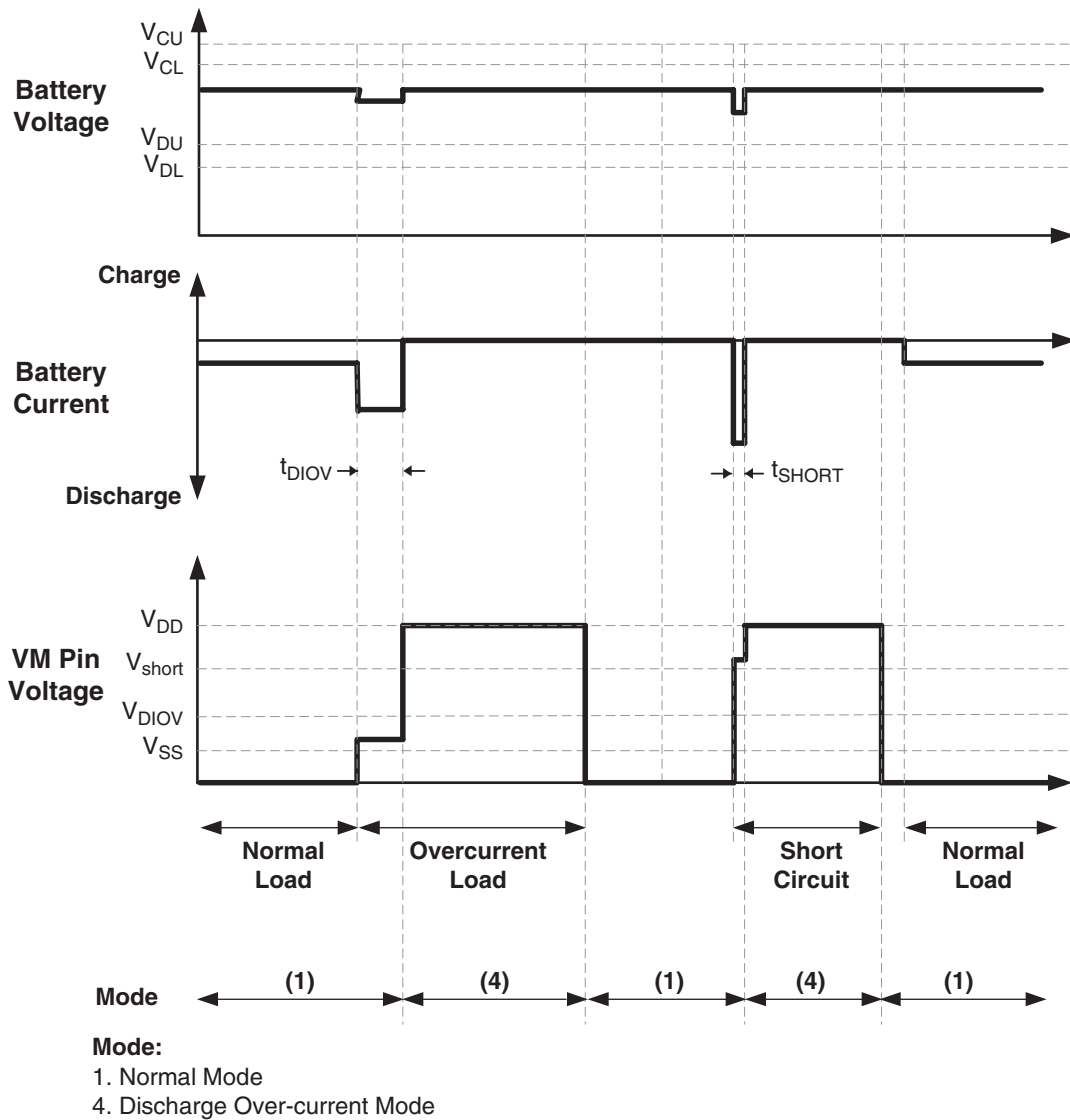

Figure 4. Discharging Over-current Detection Timing Diagram

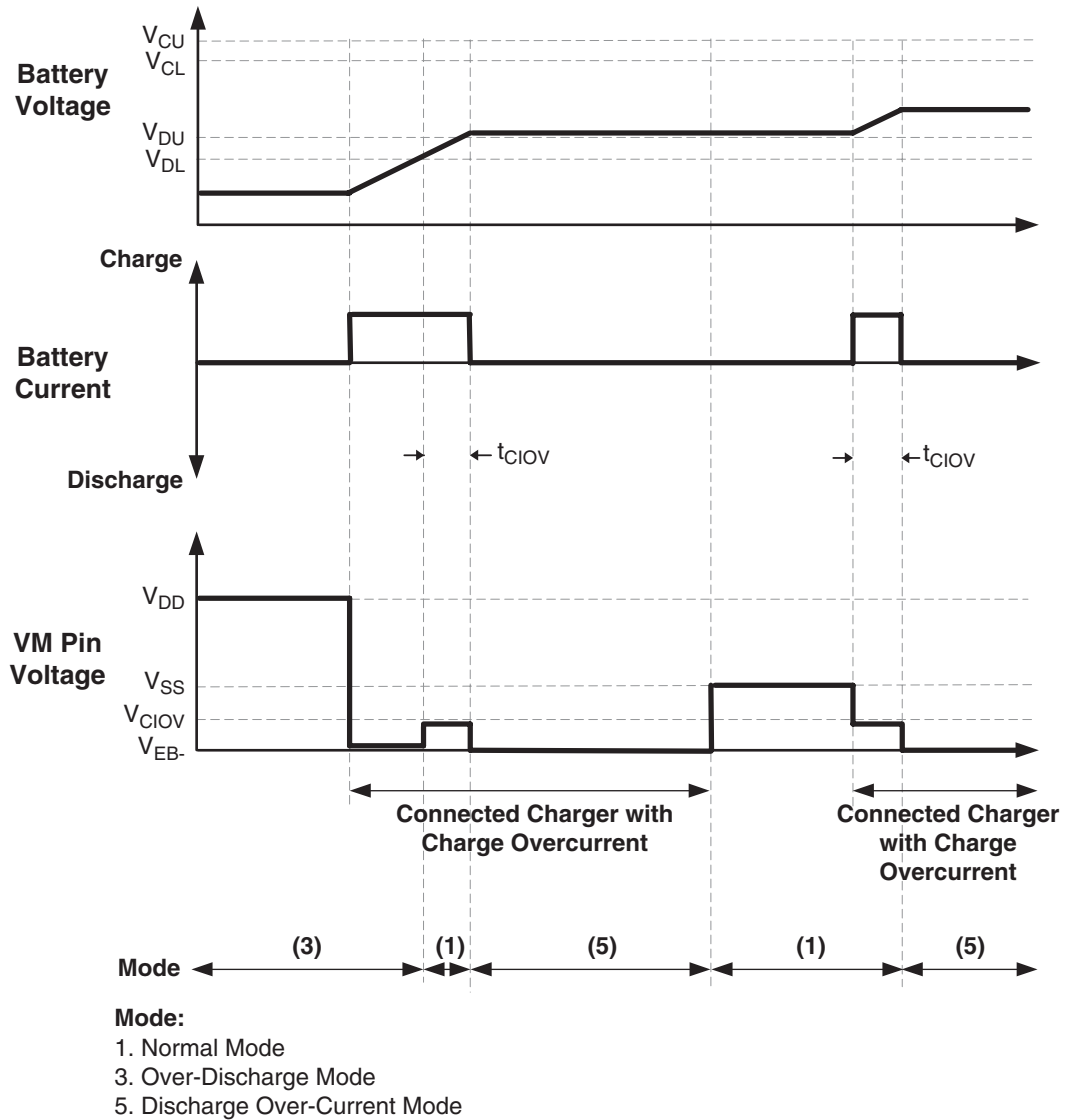

Figure 5. Charging Over-current Detection Timing Diagram

Applications Information

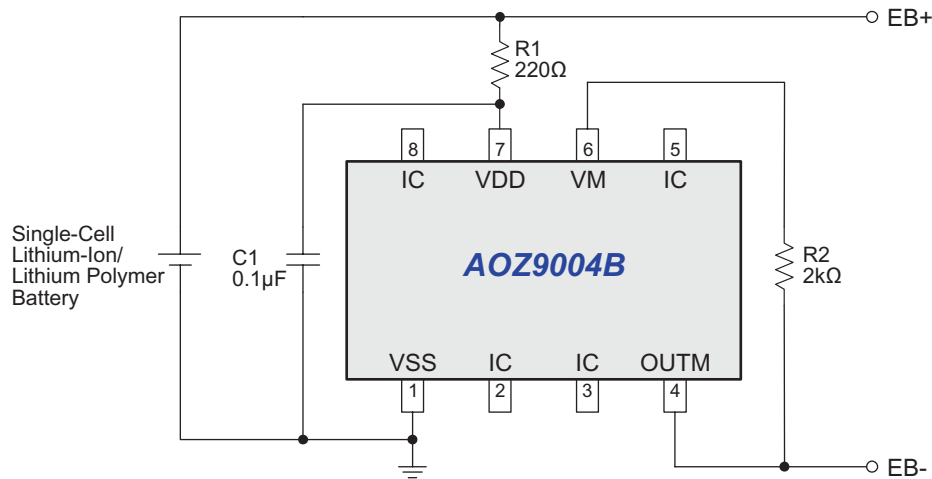

Figure 6. AOZ9004B Applications Circuit

A low-pass filter formed by R1 and C1 reduces supply voltage fluctuation on the VDD pin. R1 also provides ESD protection and serves as a current-limiting resistor in the event of charger reverse connection. The supply current of AOZ9004B has to flow through R1, so a small R1 should be chosen to guarantee detection accuracy of VDD voltage. Choose a resistor value between 100Ω and 330Ω for R1. Choose the value of C1 to be 0.022μF or higher. Both R1 and C1 should be placed as close as possible to AOZ9004B to minimize parasitic effect.

R2 provides ESD protection and serve as a current-limiting resistor in the event of charger reverse connection. A large value resistor should be chosen to limit power consumption during this condition. However, an extremely large value of R2, of course, will cause inaccuracy of VM pin voltage detection. Choose a resistor value between 300Ω and 4kΩ for R2.

Table 3. External Components Selection Range

Designator	Purpose	Min.	Typ.	Max.C
C1	Reduce supply voltage fluctuation, provide ESD protection, and limit current when a charger is reversely connected	0.022μF	0.1μF	1.0μF
R1	Reduce supply voltage fluctuation	100Ω	220Ω	330Ω
R2	Provide ESD protection and limit current when a charger is reversely connected	300Ω	2kΩ	4kΩ

Package Dimensions, TSSOP-8L

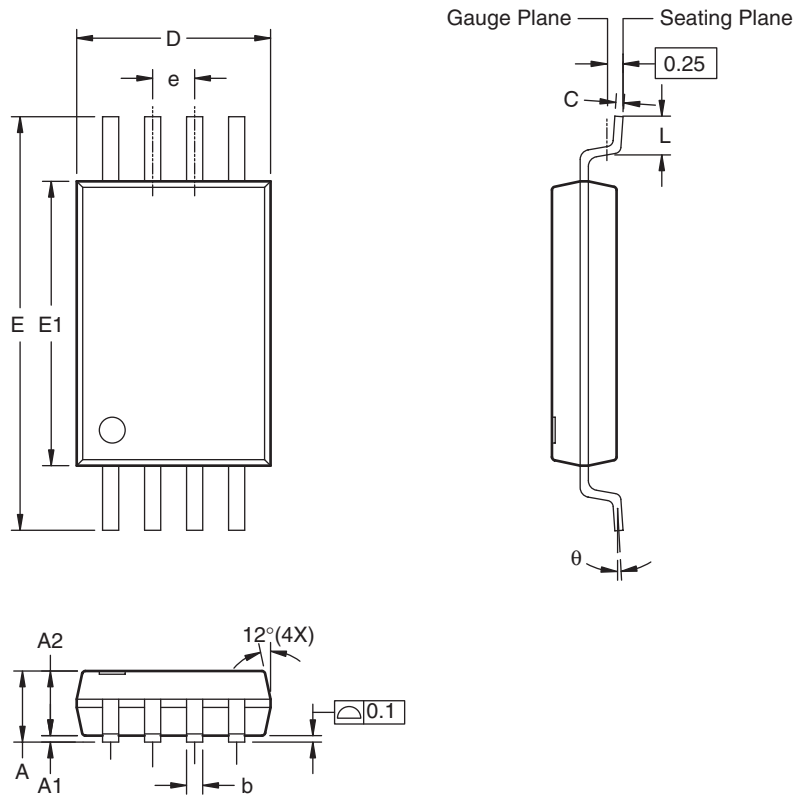

Recommended Land Pattern

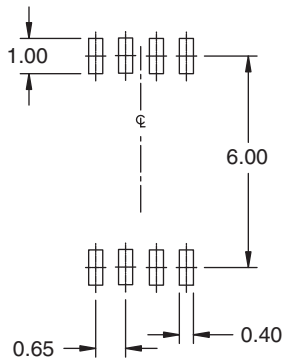

UNIT: mm

Dimensions in millimeters

Symbols	Min.	Nom.	Max.
A	—	—	1.20
A1	0.05	—	0.15
A2	0.80	1.00	1.05
b	0.19	—	0.30
C	0.09	—	0.20
D	2.90	3.00	3.10
E	6.40 BSC		
E1	4.30	4.40	4.50
e	0.65 BSC		
L	0.45	0.60	0.75
θ	0°	—	8°

Dimensions in inches

Symbols	Min.	Nom.	Max.
A	—	—	0.047
A1	0.002	—	0.006
A2	0.031	0.039	0.041
b	0.007	—	0.012
C	0.004	—	0.008
D	0.114	0.118	0.122
E	0.252 BSC		
E1	0.169	0.173	0.177
e	0.026 BSC		
L	0.018	0.024	0.030
θ	0°	—	8°

Notes:

- All dimensions are in millimeters.
- Dimensions are inclusive of plating
- Package body sizes exclude mold flash and gate burrs. Mold flash at the non-lead sides should be less than 6 mils.
- Dimension L is measured in gauge plane.
- Controlling dimension is millimeter, converted inch dimensions are not necessarily exact.
- Refer to JEDEC MO-153(AA).

Tape and Reel Dimensions, TSSOP-8L

TSSOP-8 Carrier Tape

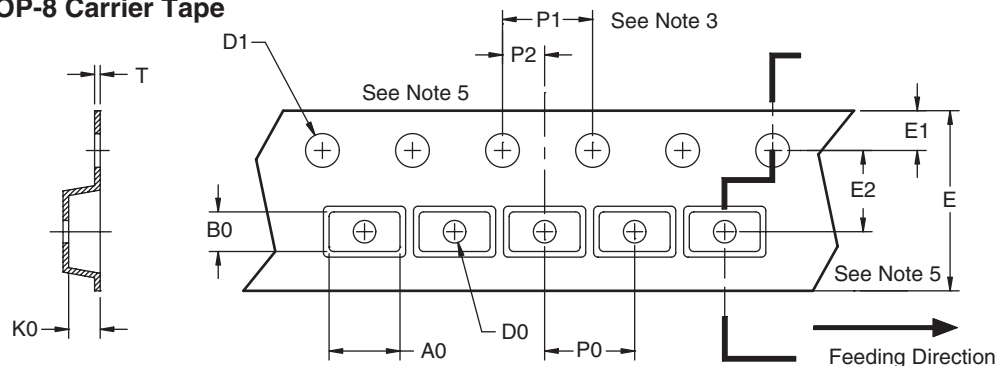

Unit: mm

Package	A0	B0	K0	D0	D1	E	E1	E2	P0	P1	P2	T
TSSOP-8 (12mm)	6.80 ±0.10	3.40 ±0.10	1.60 ±0.10	1.50 ±0.10	1.50 Min.	12.00 ±0.30	1.75 ±0.10	5.50 ±0.05	8.00 ±0.10	4.00 ±0.10	2.00 ±0.10	0.30 ±0.05

TSSOP-8 Reel

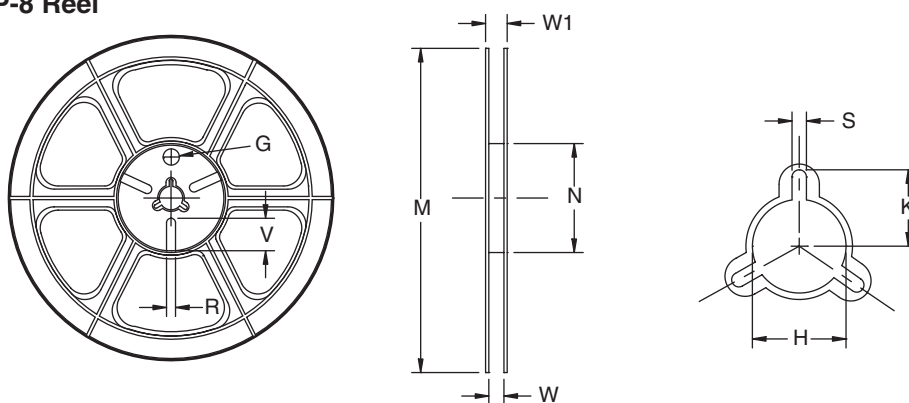

Tape Size	Reel Size	M	N	W	W1	H	K	S	G	R	V
12mm	ø330	ø178.00 ±0.50	ø60.00 ±0.10	13.00 +1.50/-0.00	16.00 ±1.00	ø13.50 ±0.50	10.60	2.00 ±0.50	—	—	—

TSSOP-8 Tape

Leader/Trailer
& Orientation

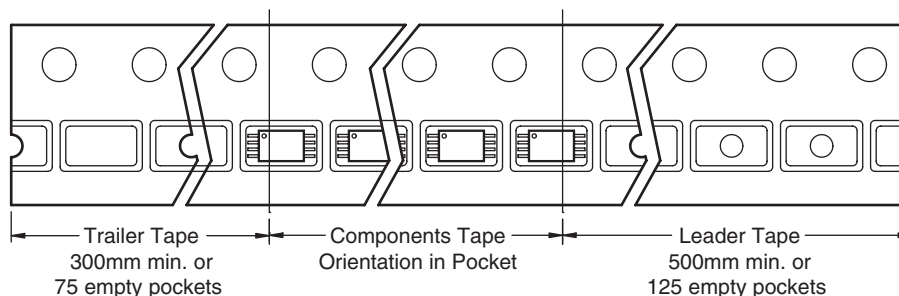

AOZ9004B Package Marking

