

DESCRIPTION

The Microsemi LX2203A is a tiny linear battery charger for Lithium Ion or Lithium Polymer batteries. The LX2203A includes built in MOSFET, accurate current and voltage regulation, reverse blocking protection, over temperature control, and charge status indicator. The accurate programmable charge current and independent termination current programming make it easy to logically reprogram the charge current limit at any time.

The LX2203A charges the battery in two phases: constant current and constant voltage. A reduced current conditioning mode is provided for deeply discharged batteries. The LX2203A automatically restarts if the battery voltage falls below the top-off threshold. The LX2203A enters a low quiescent current sleep mode when power is removed.

The LX2203A is backward compatible with the LX2203. The difference is the LX2203A can terminate charging while using CCP resistors ranging from 90k to 1.5M and the LX2203 from 90k to 400k.

IMPORTANT: For the most current data, consult MICROSEMI's website: <http://www.microsemi.com>

KEY FEATURES

- Up to 1A Charge Current
- Low Drop Out Design
- Reverse Leakage Protection
- Linear Thermal Control Loop
- Pre-Charge Conditioning
- Programmable Termination Current
- Short Circuit Protected
- Small 3x3mm MLP Package

APPLICATIONS

- PDAs, MP3 Players
- Cell Phones
- Charging Cradles
- Digital Cameras

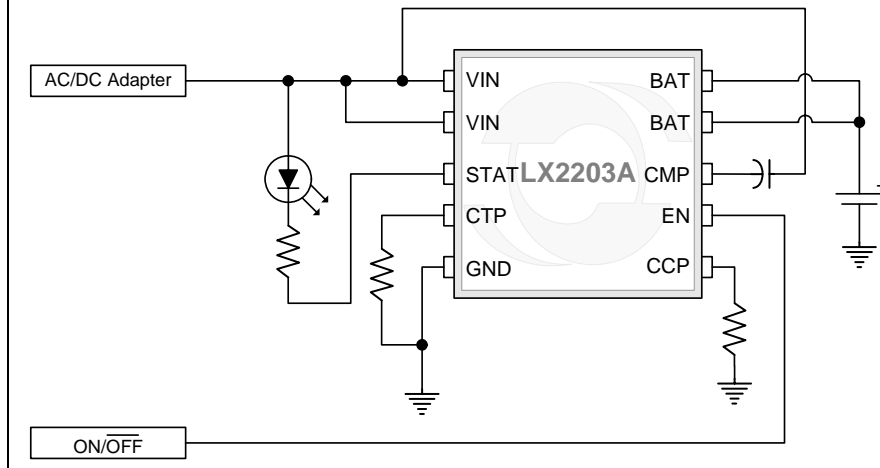
PRODUCT HIGHLIGHT

EN	MODE
0	Sleep mode – charge disabled
1	Charge enabled.

PACKAGE ORDER INFO

T_A (°C)	LD Plastic MLP 10-Pin
	RoHS Compliant / Pb-free
-40 to 85	LX2203AILD

Note: Available in Tape & Reel. Append the letters "TR" to the part number. (i.e. LX2203AILD-TR)

ABSOLUTE MAXIMUM RATINGS

Supply Voltage (VIN).....	-0.3V to 7V
Input Signals (SHDN, EN,CMP)	-0.3V to 7V
Battery Charging Current (I _{BAT}).....	1.2A
Operating Junction Temperature.....	-40C to 150°C
Storage Temperature Range.....	-65°C to 150°C
Peak Package Solder Reflow Temp(40 seconds max. exposure)	260°C (+0 -5)

Note: Exceeding these ratings could cause damage to the device. All voltages are with respect to Ground. Currents are positive into, negative out of specified terminal.

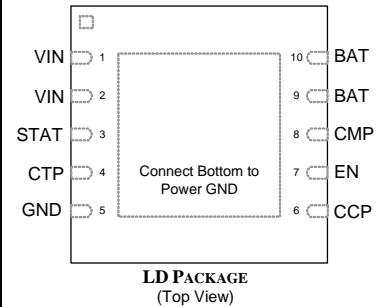
PACKAGE PIN OUT

RoHS / Pb-free 100% Matte Tin Lead Finish

THERMAL DATA
LD Plastic Micro Leadframe Package 10-Pin

THERMAL RESISTANCE-JUNCTION TO AMBIENT, θ_{JA}

49°C/W

Junction Temperature Calculation: $T_J = T_A + (P_D \times \theta_{JA})$.

The θ_{JA} numbers are guidelines for the thermal performance of the device/pc-board system. All of the above assume no ambient airflow.

FUNCTIONAL PIN DESCRIPTION

Name	Description
BAT	Charging Output - This pin is wired to the positive terminal of the battery. (The negative battery terminal is wired to GND.)
CCP	Charge Current Programming Pin - A resistor (R _{ccp}) is connected between this pin and GND. See application section for programming information.
CMP	Compensation Pin – Apply a 0.01 μ F capacitor between CMP and VIN pins.
CTP	Charge Termination Programming Pin – A resistor (R _{ctp}) is connected between this pin and GND See application section for programming information.
EN	Enable - Applying a TTL compatible Hi signal enables the charger, a Low signal disables the charger and puts it in sleep mode.
GND	Common Ground.
STAT	Status - This pin is a logic low level when the battery is being charged. Pin can sink up to 5mA.
VIN	Voltage Input – Supply Voltage. Must be greater than V _{BAT} to charge.

ELECTRICAL CHARACTERISTICS

Unless otherwise specified, the following specifications apply over the ambient temperature $0^{\circ}\text{C} \leq T_A \leq 70^{\circ}\text{C}$ except where otherwise noted and the following test conditions: $V_{VIN} = 5\text{V}$, $V_{BAT} = 3.8\text{V}$, $R_{CCP} = 90.9\text{k}$, $R_{CTP} = 150\text{k}$.

Parameter	Symbol	Test Conditions	LX2203A			Units
			Min	Typ	Max	
MAIN CIRCUITRY						
Input Voltage	V_{VIN}		4.35		6	V
Quiescent Current	I_{GND}	$V_{EN} = \text{Hi}$		3	5	mA
		$V_{EN} = \text{Lo}$		7		μA
CTP Bias Voltage	V_{CTP}			1.25		V
CCP Bias Voltage	V_{CCP}			1.25		V
CONSTANT VOLTAGE MODE						
BAT Output Voltage	$V_{BAT(\text{MAX})}$		4.16	4.2	4.24	V
Top Off Charge Droop Threshold	V_{DRP}	$V_{DRP} / V_{BAT(\text{MAX})}$	96	97	98	%
Charge Termination Taper Current		$V_{BAT} = V_{BAT(\text{MAX})}$	42	51	60	mA
Taper Current @ Low Charge Level		$V_{BAT} = V_{BAT(\text{MAX})}$; $R_{CCP} = 1.2\text{M}$	37	48	60	mA
CONSTANT CURRENT MODE						
BAT Constant Current			0.9	1.0	1.1	A
Conditioning Current	I_{COND}	$V_{BAT} < V_{BAT(\text{COND})}$	4%	5%	6%	$\frac{I_{COND}}{I_{BAT}}$
Conditioning Current Mode Threshold Voltage	$V_{BAT(\text{COND})}$	$V_{BAT(\text{COND})} / V_{BAT(\text{MAX})}$	60	63	66	%
LOGIC						
STAT Logic High Output	V_{STAT}	$I_{STAT} = -100\mu\text{A}$	4.5			V
STAT Logic Low Output	V_{STAT}	$I_{STAT} = 5\text{mA}$			0.5	V
EN Select Threshold	V_{EN}	Logic Hi	2.0			
		Logic Lo			0.8	
EN bias current	I_{EN}	$V_{EN} = \text{Hi}$		8		μA
THERMAL SHUTDOWN						
Maximum Junction Temperature	T_J			150		$^{\circ}\text{C}$
PASS ELEMENT						
Reverse mode current	$-I_{BAT}$	$V_{VIN} < V_{BAT}$		5		μA
UNDER VOLTAGE LOCKOUT						
Rising Threshold Voltage	V_{UVLO+}			4.2		V
Falling Threshold Voltage	V_{UVLO-}			3.9		V

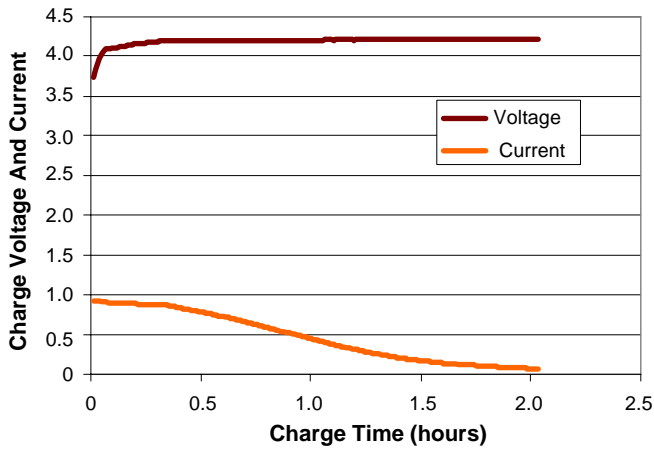
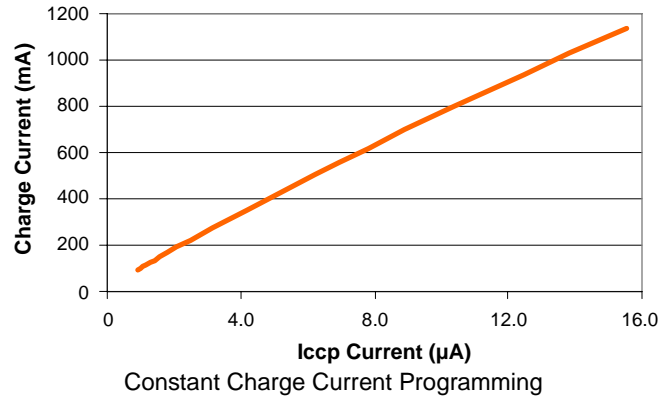
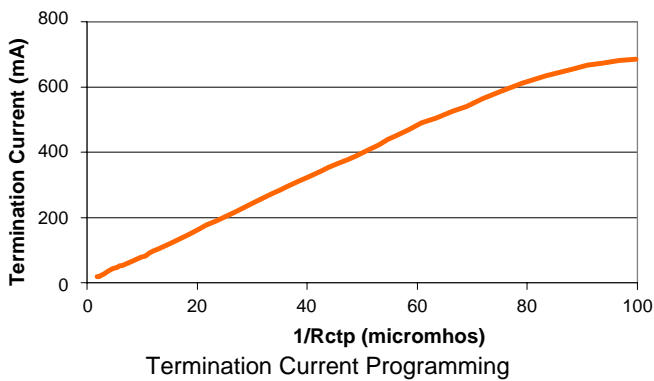
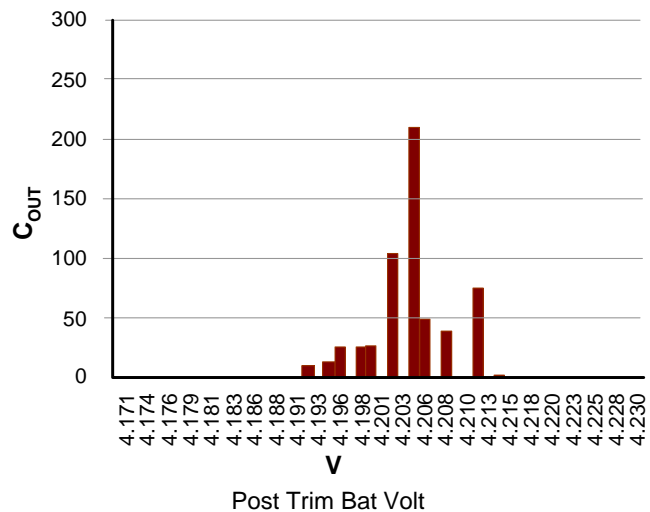
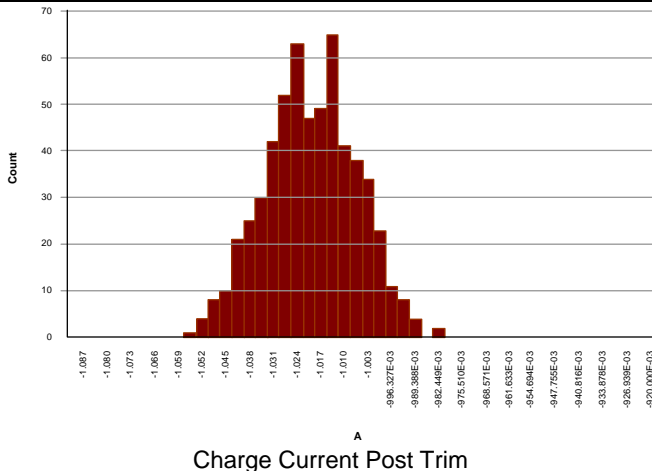
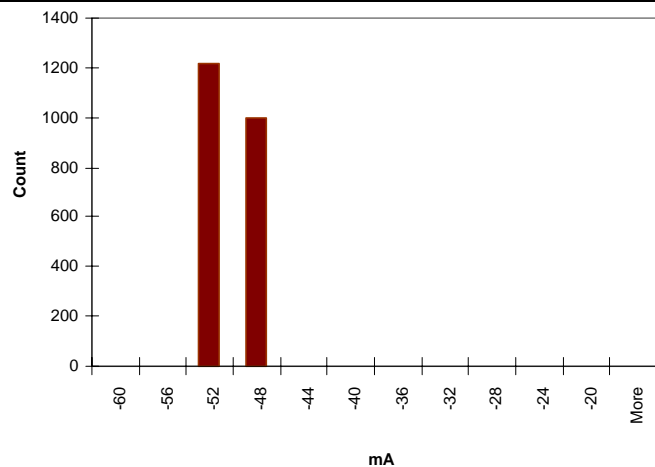
CHARGING PROFILE

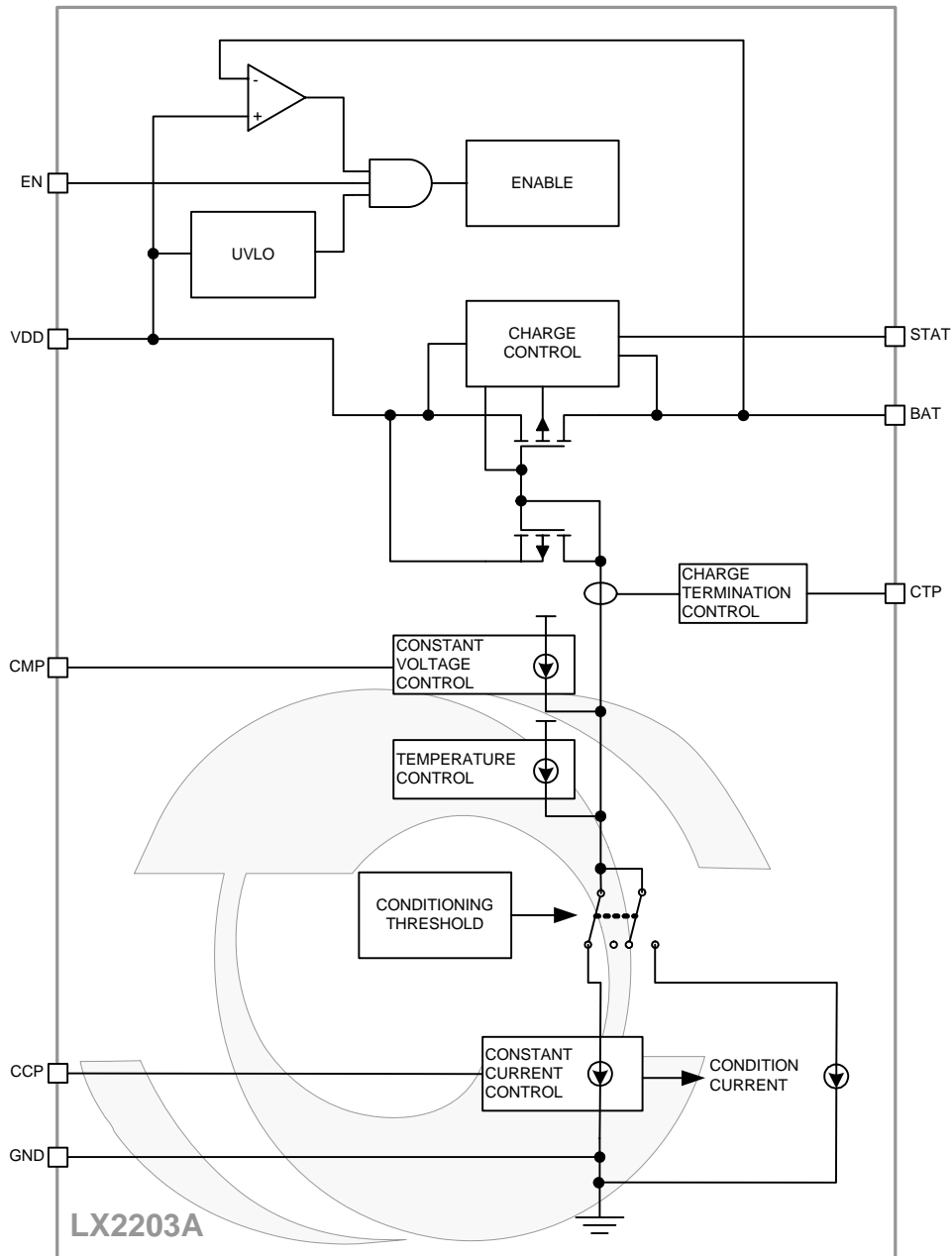
CHARGE CURRENT PROGRAMMING

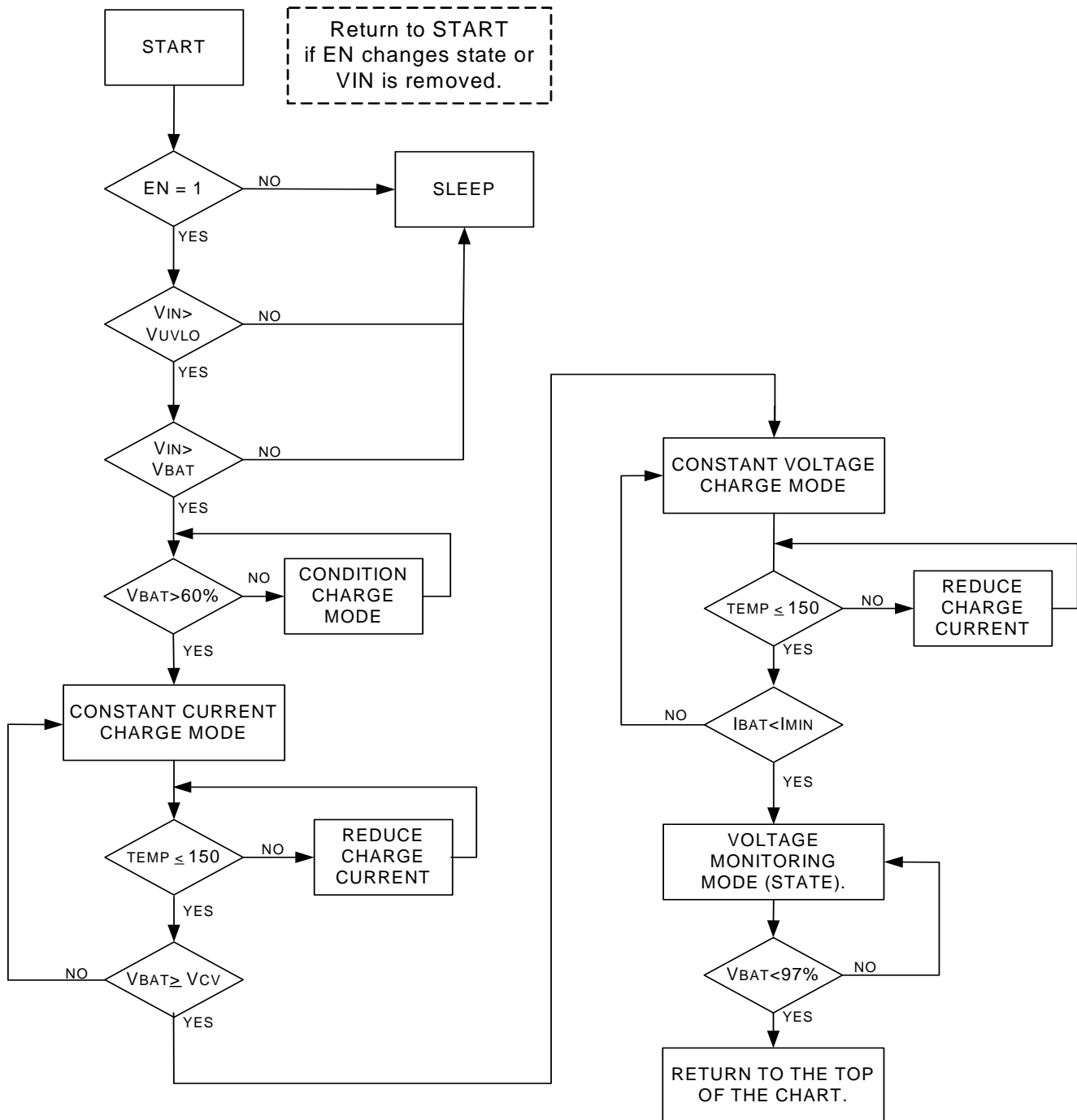
TERMINATION CURRENT PROGRAMMING

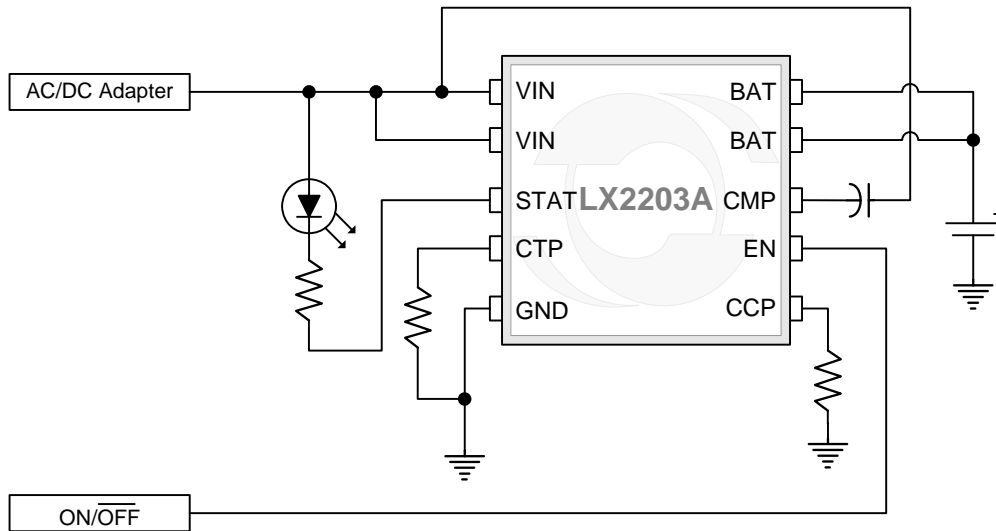
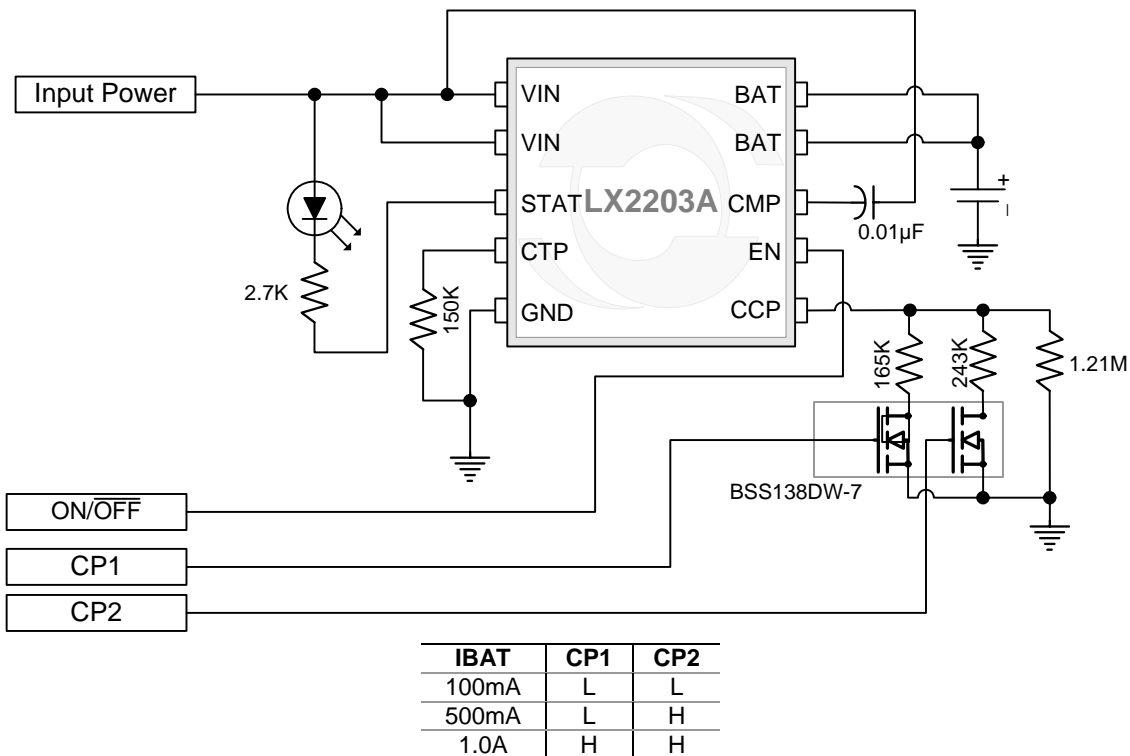
CHARGE VOLTAGE DISTRIBUTION

1.0A CHARGE CURRENT DISTRIBUTION

50mA TERMINATION DISTRIBUTION

SIMPLIFIED BLOCK DIAGRAM

Figure 1 – Simplified Block Diagram

THEORY OF OPERATION
LX2203 CONTROL FLOW DIAGRAM

Figure 2 – Control Flow Diagram

TYPICAL APPLICATIONS

Figure 3 –Basic charger from Wall Adapter with 1A constant current and 50mA termination current

Figure 4 – Wall adapter and USB Charger (1A, 500mA, 100mA, selectable)

APPLICATION NOTE
GENERAL DESCRIPTION

The LX2203A is designed to charge a single cell Lithium Ion (Li-ion) battery using two modes: a constant current mode, where the charge current is held constant and the battery terminal voltage rises to 4.2V; this is followed by constant voltage mode, where the battery voltage is held at 4.2V and the charge current starts to taper off. Once the taper current reaches the charge termination current level the charge cycle is ended and the STAT indicator turns off. If the fully charged battery terminal voltage drops to 4.07V, the battery charge cycle will be restarted.

PROTECTION FEATURES

Conditioning Current Mode – If the battery terminal voltage is less than 2.65V, the battery charger will reduce the charge current to 5%. This also protects the appliance from overheating by trying to drive the full charging current into a damaged battery.

Under Voltage Lockout – The charge cycle will not start until the VIN voltage rises above 4.2V. Hysteresis prevents chattering on and off.

Thermal Control loop – If the power dissipation of the charger becomes excessive, the charge current will be reduced to prevent the die temperature from getting above 150°C. This does not cause the charge cycle to stop.

Reverse current blocking – If VIN is grounded, current will not flow from the battery through the charger. No external blocking diode is required on the input.

Sleep Mode – If the EN pin is logic low or if VIN is removed, the charger enters a sleep mode where a very low quiescent current prevents drain from the battery.

LAYOUT GUIDELINES

- It is important when laying out the LX2203A to place 10µF ceramic capacitors close to the VIN and V_{BAT} IC terminals to filter switching transients.
- It is important to provide a low thermal impedance path from the thermal pad on the bottom of the LX2203A package to the ground plane of the circuit board to maximize the heat dissipation. To minimize charge time it is best not to rely on the thermal control feature as this feature will extend the charging time when activated.

TERMINATION CURRENT PROGRAMMING

The charge termination current (or minimum taper current) is set by selecting a value for the CTP resistor using the following formula:

$$R_{CTP} = \frac{7500}{I_{TERM}}$$

For example, for a termination current of 50mA set R_{CTP} = 150k. This formula applies to termination currents ranging from 20mA to 500mA.

It is possible to change the termination current to different levels for different charge rates. For a “quick charge”, the termination current can be set to about 50% of the constant current level; this charges the battery to about 75% capacity. For a full charge (taking several hours) the termination current can be set to 5% of the constant current level. The circuit below allows switching between the two levels:

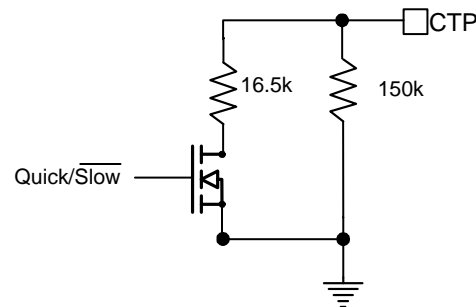

Figure 5 – 500mA or 50mA termination current

CONSTANT CHARGE CURRENT PROGRAMMING

The charge current during the constant current charge mode is programmable by controlling the current flowing from the CCP pin. A graph showing this relationship is included in this specification. The CCP pin is regulated to 1.25V when the charger is active. Connecting a resistor from the CTP to ground will produce a CTP current of:

$$I_{CTP} = \frac{1.25}{R_{CCP}}$$

(Continued on next page)

APPLICATION NOTE (CONTINUED)
**CONSTANT CHARGE CURRENT PROGRAMMING
(CONTINUED)**

The table below lists some popular Constant Current Settings along with the associated CCP pin current and programming resistor:

Charge Current	I _{CCP} Current	R _{CCP} Value
1.0A	13.75μA	90.9K
500mA	6.22μA	200K
100mA	1.00μA	1200K

It is possible to change the constant current setting by changing the R_{CCP} resistor while in charge mode. Since the termination current is independent of the charge current, lowering the constant charge current will increase the charge time, but will not reduce the stored charge in the battery at the charge termination point.

The circuit in **Figure 4** is an example of a battery charger configured to charge at 1A, 500mA or 100mA. The switches are logically controlled and reduce the resistance at the CCP pin when switched in. It is possible to eliminate the MOSFET devices if open drain logic is available.

The logic for the CP1 and CP2 would normally come from the appliance processor which would need to have the capability to communicate over the USB interface. If there is only one power connector and the USB interface is active, the logic could assume the power was coming from the USB bus and not the wall adapter. If the USB interface is active, the USB application will know if the appliance has been enumerated as a high or low load and would set CP1 and CP2 appropriately.

It is possible to change the current programming circuit to drive it directly with CMOS logic, but this requires that the CMOS logic power supply be well regulated (±2%). Each switch resistor leg in Figure 4 can be replaced with a two resistor network tied to the output of a CMOS gate.

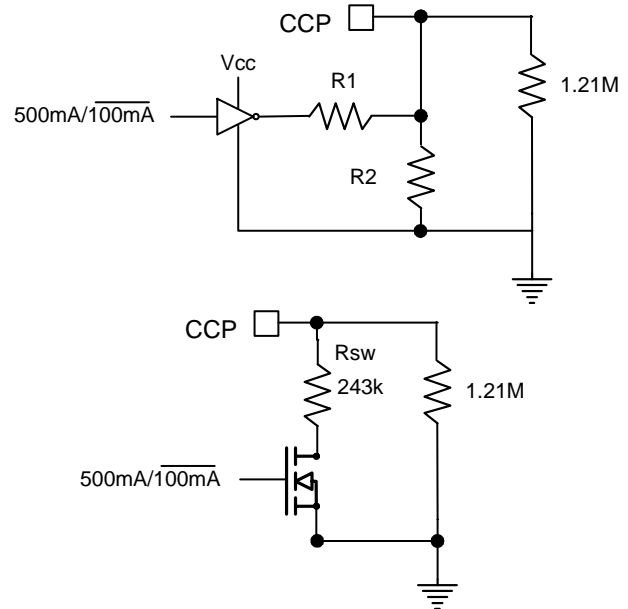

Figure 6 – Circuits to provide 100mA and 500mA constant charge currents.

The values of R₁ and R₂ are selected such that:

$$V_{CC} \times \frac{R_2}{R_1 + R_2} = 1.25 \quad \& \quad \frac{R_1 \times R_2}{R_1 + R_2} = R_{SW}$$

Solving these equations:

$$R_1 = \frac{V_{CC} \times R_{SW}}{1.25} \quad \& \quad R_2 = \frac{R_1 \times R_{SW}}{R_1 - R_{SW}}$$

For V_{CC} = 3.3V and R_{SW} = 243k; R₁ = 649k; R₂ = 392k. These values should provide charge currents of 100mA and 500mA.

COMPENSATION CAPACITOR

A compensation capacitor of value 0.01μF is required between the CMP pin and V_{IN}.

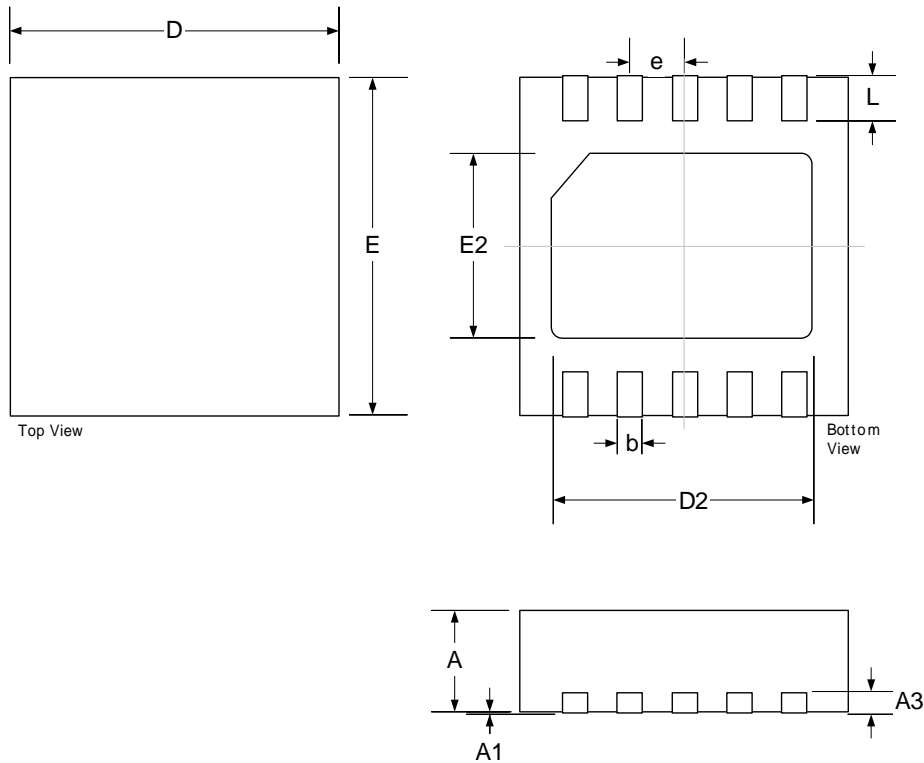
PACKAGE DIMENSIONS
LD 10-Pin Plastic MLP Dual Exposed Pad

Dim	MILLIMETERS		INCHES	
	MIN	MAX	MIN	MAX
A	0.80	1.00	0.0315	0.0394
A1	0	0.05	0	0.0019
A3	0.20 REF		0.0079 REF	
b	0.18	0.30	0.0071	0.0118
D	3.00 BSC		0.1181 BSC	
D2	2.23	2.48	0.0878	0.0976
e	0.50 BSC		0.0197 BSC	
E	3.00 BSC		0.1181 BSC	
E2	1.49	1.74	0.0587	0.0685
L	0.30	0.50	0.0071	0.0197

Note:

- Dimensions do not include mold flash or protrusions; these shall not exceed 0.155mm (.006") on any side. Lead dimension shall not include solder coverage.



Microsemi[®]

LX2203A

Li-Ion Battery Charger

PRODUCTION DATA SHEET

NOTES

PRODUCTION DATA – Information contained in this document is proprietary to Microsemi and is current as of publication date. This document may not be modified in any way without the express written consent of Microsemi. Product processing does not necessarily include testing of all parameters. Microsemi reserves the right to change the configuration and performance of the product and to discontinue product at any time.