

BATTERY PROTECTION IC FOR 1-CELL PACK

S-8211C Series

The S-8211C Series are protection ICs for single-cell lithium-ion / lithium polymer rechargeable batteries and include high-accuracy voltage detectors and delay circuits.

These ICs are suitable for protecting single-cell rechargeable lithium-ion / lithium polymer battery packs from overcharge, overdischarge, and overcurrent.

Features

- (1) High-accuracy voltage detection circuit
 - Overcharge detection voltage 3.9 V to 4.4 V (5 mV steps) Accuracy ± 25 mV (+25°C)
Accuracy ± 30 mV (−5°C to +55°C)
 - Overcharge release voltage 3.8 V to 4.4 V*¹ Accuracy ± 50 mV
 - Overdischarge detection voltage 2.0 V to 3.0 V (10 mV steps) Accuracy ± 50 mV
 - Overdischarge release voltage 2.0 V to 3.4 V*² Accuracy ± 100 mV
 - Discharge overcurrent detection voltage 0.05 V to 0.30 V (10 mV steps) Accuracy ± 15 mV
 - Load short-circuiting detection voltage 0.5 V (fixed) Accuracy ± 200 mV
 - Charge overcurrent detection voltage −0.1 V (fixed) Accuracy ± 30 mV
 - (2) Detection delay times are generated by an internal circuit (external capacitors are unnecessary). Accuracy $\pm 20\%$
 - (3) High-withstanding-voltage device is used for charger connection pins (VM pin and CO pin : Absolute maximum rating = 28 V)
 - (4) 0 V battery charge function available / unavailable are selectable.
 - (5) Wide operating temperature range −40°C to +85°C
 - (6) Low current consumption
 - Operation mode 3.0 μ A typ., 5.5 μ A max. (+25°C)
 - Power-down mode 0.2 μ A max. (+25°C)
 - (7) Small package SOT-23-5, SNT-6A
 - (8) Lead-free product
- *1. Overcharge release voltage = Overcharge detection voltage – Overcharge hysteresis voltage
(Overcharge hysteresis voltage can be selected as 0 V or from a range of 0.1 V to 0.4 V in 50 mV steps.)
- *2. Overdischarge release voltage = Overdischarge detection voltage + Overdischarge hysteresis voltage
(Overdischarge hysteresis voltage can be selected as 0 V or from a range of 0.1 V to 0.7 V in 100 mV steps.)

Applications

- Lithium-ion rechargeable battery packs
- Lithium polymer rechargeable battery packs

Packages

Package Name	Drawing Code			
	Package	Tape	Reel	Land
SOT-23-5	MP005-A	MP005-A	MP005-A	–
SNT-6A	PG006-A	PG006-A	PG006-A	PG006-A

■ **Block Diagram**

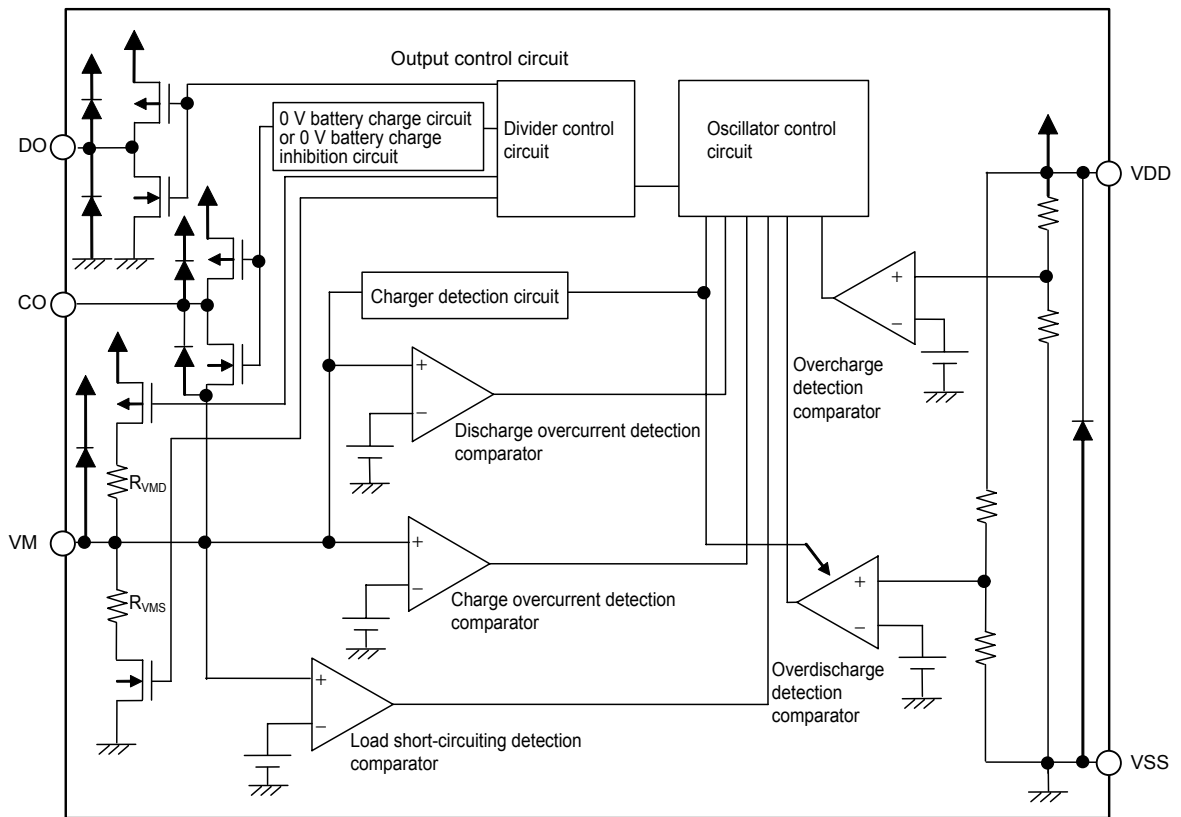

Remark All diodes shown in figure are parasitic diodes.

Figure 1

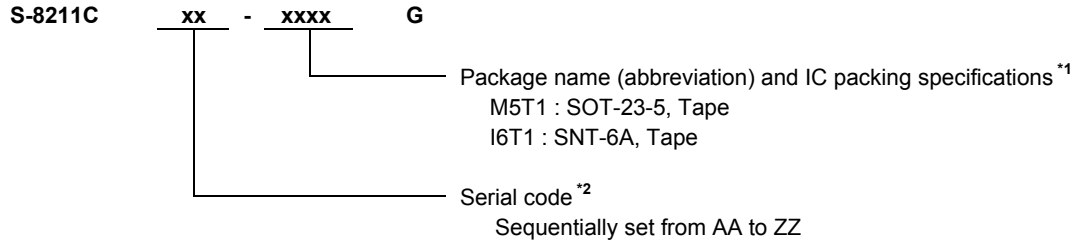
■ Product Name Structure**1. Product Name**

*1. Refer to the tape specifications.

*2. Refer to the "2. Product Name List".

2. Product Name List

(1) SOT-23-5

Table 1

Product Name / Item	Overcharge Detection Voltage [V _{CU}]	Overcharge Release Voltage [V _{CL}]	Over-discharge Detection Voltage [V _{DL}]	Over-discharge Release Voltage [V _{DU}]	Discharge Overcurrent Detection Voltage [V _{DIOV}]	0 V Battery Charge Function	Delay Time Combination*1
S-8211CAA-M5T1G	4.275 V	4.175 V	2.30 V	2.40 V	0.10 V	Available	(1)
S-8211CAB-M5T1G	4.325 V	4.075 V	2.50 V	2.90 V	0.15 V	Unavailable	(2)
S-8211CAD-M5T1G	4.350 V	4.150 V	2.30 V	3.00 V	0.20 V	Available	(3)
S-8211CAE-M5T1G	4.280 V	4.180 V	2.30 V	2.30 V	0.12 V	Available	(4)
S-8211CAF-M5T1G	4.275 V	4.275 V	2.30 V	2.30 V	0.10 V	Available	(5)
S-8211CAH-M5T1G	4.280 V	4.080 V	2.30 V	2.30 V	0.08 V	Available	(1)
S-8211CAI-M5T1G	4.280 V	4.080 V	2.30 V	2.30 V	0.10 V	Available	(1)
S-8211CAJ-M5T1G	4.280 V	4.080 V	2.30 V	2.30 V	0.10 V	Unavailable	(1)
S-8211CAK-M5T1G	4.280 V	4.080 V	2.30 V	2.30 V	0.13 V	Unavailable	(1)
S-8211CAL-M5T1G	4.280 V	4.130 V	2.60 V	3.10 V	0.15 V	Unavailable	(1)
S-8211CAM-M5T1G	4.280 V	4.130 V	2.80 V	3.10 V	0.15 V	Unavailable	(1)
S-8211CAN-M5T1G	4.200 V	4.100 V	2.80 V	2.90 V	0.15 V	Unavailable	(1)
S-8211CAO-M5T1G	4.275 V	4.075 V	2.30 V	2.30 V	0.12 V	Available	(5)
S-8211CAP-M5T1G	4.275 V	4.075 V	2.30 V	2.30 V	0.13 V	Available	(5)
S-8211CAQ-M5T1G	4.275 V	4.075 V	2.30 V	2.30 V	0.15 V	Available	(5)
S-8211CAR-M5T1G	4.275 V	4.075 V	2.30 V	2.30 V	0.15 V	Available	(1)
S-8211CAS-M5T1G	4.280 V	4.130 V	2.80 V	3.10 V	0.10 V	Unavailable	(1)
S-8211CAT-M5T1G	4.275 V	4.075 V	2.80 V	3.10 V	0.10 V	Available	(4)
S-8211CAU-M5T1G	4.280 V	4.130 V	2.80 V	3.10 V	0.05 V	Unavailable	(1)
S-8211CAV-M5T1G	4.325 V	4.075 V	2.50 V	2.90 V	0.15 V	Available	(2)
S-8211CAY-M5T1G	4.280 V	4.280 V	2.80 V	2.80 V	0.05 V	Available	(1)
S-8211CAZ-M5T1G	4.280 V	4.280 V	3.00 V	3.00 V	0.075 V	Available	(1)
S-8211CBV-M5T1G	4.280 V	4.080 V	2.80 V	2.80 V	0.15 V	Available	(4)

*1. Refer to the **Table 3** about the details of the delay time combinations (1) to (7).

Remark Please contact our sales office for the products with detection voltage value other than those specified above.

BATTERY PROTECTION IC FOR 1-CELL PACK
S-8211C Series

Rev.5.4_00

(2) SNT-6A

Table 2

Product Name / Item	Overcharge Detection Voltage [V _{CU}]	Overcharge Release Voltage [V _{CL}]	Over-discharge Detection Voltage [V _{DL}]	Over-discharge Release Voltage [V _{DU}]	Discharge Overcurrent Detection Voltage [V _{DIOV}]	0 V Battery Charge Function	Delay Time Combination*1
S-8211CAA-I6T1G	4.275 V	4.175 V	2.30 V	2.40 V	0.10 V	Available	(1)
S-8211CAB-I6T1G	4.325 V	4.075 V	2.50 V	2.90 V	0.15 V	Unavailable	(2)
S-8211CAD-I6T1G	4.350 V	4.150 V	2.30 V	3.00 V	0.20 V	Available	(3)
S-8211CAE-I6T1G	4.280 V	4.180 V	2.30 V	2.30 V	0.12 V	Available	(4)
S-8211CAF-I6T1G	4.275 V	4.275 V	2.30 V	2.30 V	0.10 V	Available	(5)
S-8211CAH-I6T1G	4.280 V	4.080 V	2.30 V	2.30 V	0.08 V	Available	(1)
S-8211CAI-I6T1G	4.280 V	4.080 V	2.30 V	2.30 V	0.10 V	Available	(1)
S-8211CAJ-I6T1G	4.280 V	4.080 V	2.30 V	2.30 V	0.10 V	Unavailable	(1)
S-8211CAK-I6T1G	4.280 V	4.080 V	2.30 V	2.30 V	0.13 V	Unavailable	(1)
S-8211CAL-I6T1G	4.280 V	4.130 V	2.60 V	3.10 V	0.15 V	Unavailable	(1)
S-8211CAM-I6T1G	4.280 V	4.130 V	2.80 V	3.10 V	0.15 V	Unavailable	(1)
S-8211CAN-I6T1G	4.200 V	4.100 V	2.80 V	2.90 V	0.15 V	Unavailable	(1)
S-8211CAO-I6T1G	4.275 V	4.075 V	2.30 V	2.30 V	0.12 V	Available	(5)
S-8211CAP-I6T1G	4.275 V	4.075 V	2.30 V	2.30 V	0.13 V	Available	(5)
S-8211CAQ-I6T1G	4.275 V	4.075 V	2.30 V	2.30 V	0.15 V	Available	(5)
S-8211CAR-I6T1G	4.275 V	4.075 V	2.30 V	2.30 V	0.15 V	Available	(1)
S-8211CAS-I6T1G	4.280 V	4.130 V	2.80 V	3.10 V	0.10 V	Unavailable	(1)
S-8211CAT-I6T1G	4.275 V	4.075 V	2.80 V	3.10 V	0.10 V	Available	(4)
S-8211CAU-I6T1G	4.280 V	4.130 V	2.80 V	3.10 V	0.05 V	Unavailable	(1)
S-8211CAV-I6T1G	4.325 V	4.075 V	2.50 V	2.90 V	0.15 V	Available	(2)
S-8211CAW-I6T1G	4.280 V	4.080 V	2.40 V	2.40 V	0.05 V	Unavailable	(6)
S-8211CAX-I6T1G	4.275 V	4.175 V	2.30 V	2.30 V	0.12 V	Available	(4)
S-8211CAY-I6T1G	4.280 V	4.280 V	2.80 V	2.80 V	0.05 V	Available	(1)
S-8211CAZ-I6T1G	4.280 V	4.280 V	3.00 V	3.00 V	0.075 V	Available	(1)
S-8211CBA-I6T1G	4.275 V	4.175 V	2.30 V	2.40 V	0.05 V	Available	(1)
S-8211CBB-I6T1G	4.300 V	4.100 V	2.30 V	2.30 V	0.13 V	Available	(1)
S-8211CBD-I6T1G	4.275 V	4.275 V	2.30 V	2.30 V	0.05 V	Available	(5)
S-8211CBN-I6T1G	4.225 V	4.125 V	2.00 V	2.00 V	0.20 V	Unavailable	(7)
S-8211CBO-I6T1G	4.270 V	4.070 V	2.30 V	2.30 V	0.10 V	Available	(5)
S-8211CBR-I6T1G	4.280 V	4.180 V	2.30 V	2.30 V	0.12 V	Unavailable	(4)
S-8211CBW-I6T1G	4.280 V	4.180 V	2.50 V	2.70 V	0.19 V	Unavailable	(1)
S-8211CCB-I6T1G	4.250 V	4.050 V	3.00 V	3.20 V	0.10 V	Available	(1)

*1. Refer to the **Table 3** about the details of the delay time combinations (1) to (7).

Remark Please contact our sales office for the products with detection voltage value other than those specified above.

Table 3

Delay Time Combination	Overcharge Detection Delay Time [t _{CU}]	Overdischarge Detection Delay Time [t _{DL}]	Discharge Overcurrent Detection Delay Time [t _{DIOV}]	Load Short-circuiting Detection Delay Time [t _{SHORT}]	Charge Overcurrent Detection Delay Time [t _{CIOV}]
(1)	1.2 s	150 ms	9 ms	300 μs	9 ms
(2)	1.2 s	150 ms	9 ms	560 μs	9 ms
(3)	143 ms	38 ms	18 ms	300 μs	9 ms
(4)	1.2 s	150 ms	18 ms	300 μs	9 ms
(5)	1.2 s	38 ms	9 ms	300 μs	9 ms
(6)	1.2 s	150 ms	4.5 ms	300 μs	9 ms
(7)	573 ms	150 ms	4.5 ms	300 μs	4.5 ms

Remark The delay times can be changed within the range listed **Table 4**. For details, please contact our sales office.

Table 4

Delay Time	Symbol	Selection Range			Remark
Overcharge detection delay time	t _{CU}	143 ms	573 ms	1.2 s	Select a value from the left.
Overdischarge detection delay time	t _{DL}	38 ms	150 ms	300 ms	Select a value from the left.
Discharge overcurrent detection delay time	t _{DIOV}	4.5 ms	9 ms	18 ms	Select a value from the left.
Load short-circuiting detection delay Time	t _{SHORT}	–	300 μs	560 μs	Select a value from the left.
Charge overcurrent detection delay time	t _{CIOV}	4.5 ms	9 ms	18 ms	Select a value from the left.

Remark The value surrounded by bold lines is the delay time of the standard products.

■ Pin Configurations

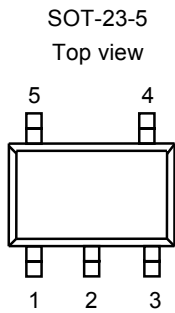

Figure 2

Table 5

Pin No.	Symbol	Description
1	VM	Voltage detection between VM pin and VSS pin (Overcurrent / charger detection pin)
2	VDD	Connection for positive power supply input
3	VSS	Connection for negative power supply input
4	DO	Connection of discharge control FET gate (CMOS output)
5	CO	Connection of charge control FET gate (CMOS output)

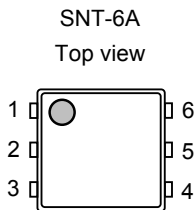

Figure 3

Table 6

Pin No.	Symbol	Description
1	NC ^{*1}	No connection
2	CO	Connection of charge control FET gate (CMOS output)
3	DO	Connection of discharge control FET gate (CMOS output)
4	VSS	Connection for negative power supply input
5	VDD	Connection for positive power supply input
6	VM	Voltage detection between VM pin and VSS pin (Overcurrent / charger detection pin)

*1. The NC pin is electrically open.
The NC pin can be connected to VDD or VSS.

■ **Absolute Maximum Ratings**

Table 7

(Ta = 25°C unless otherwise specified)

Item	Symbol	Applied pin	Absolute Maximum Ratings	Unit	
Input voltage between VDD pin and VSS pin	V _{DS}	VDD	V _{SS} - 0.3 to V _{SS} + 12	V	
VM pin input voltage	V _{VM}	VM	V _{DD} - 28 to V _{DD} + 0.3	V	
DO pin output voltage	V _{DO}	DO	V _{SS} - 0.3 to V _{DD} + 0.3	V	
CO pin output voltage	V _{CO}	CO	V _{VM} - 0.3 to V _{DD} + 0.3	V	
Power dissipation	SOT-23-5 SNT-6A	P _D	-	250 (When not mounted on board)	mW
			-	600 ^{*1}	mW
			-	400 ^{*1}	mW
Operating ambient temperature	T _{opr}	-	- 40 to + 85	°C	
Storage temperature	T _{stg}	-	- 55 to + 125	°C	

*1. When mounted on board
 [Mounted board]

- (1) Board size: 114.3 mm × 76.2 mm × t1.6 mm
- (2) Board name: JEDEC STANDARD51-7

Caution The absolute maximum ratings are rated values exceeding which the product could suffer physical damage. These values must therefore not be exceeded under any conditions.

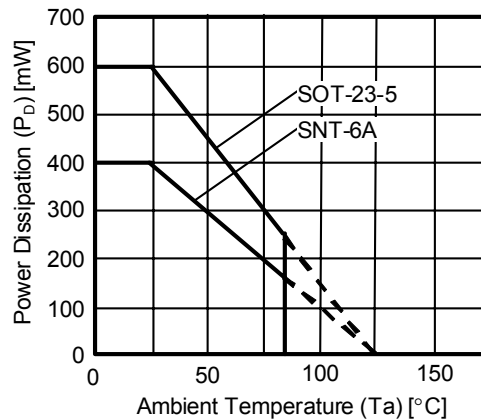

Figure 4 Power Dissipation of Package (When Mounted on Board)

BATTERY PROTECTION IC FOR 1-CELL PACK S-8211C Series

Rev.5.4_00

■ Electrical Characteristics

1. Except Detection Delay Time (25°C)

Table 8

(Ta = 25°C unless otherwise specified)

Item	Symbol	Condition	Min.	Typ.	Max.	Unit	Test Condition	Test Circuit
DETECTION VOLTAGE								
Overcharge detection voltage	V _{CU}	3.90 V to 4.40 V, Adjustable	V _{CU} -0.025	V _{CU}	V _{CU} +0.025	V	1	1
		3.90 V to 4.40 V, Adjustable, Ta = -5°C to +55°C*1	V _{CU} -0.03	V _{CU}	V _{CU} +0.03	V	1	1
Overcharge release voltage	V _{CL}	3.80 V to 4.40 V, Adjustable	V _{CL} ≠ V _{CU}	V _{CL} -0.05	V _{CL} +0.05	V	1	1
			V _{CL} = V _{CU}	V _{CL} -0.025	V _{CL} +0.025	V	1	1
Overdischarge detection voltage	V _{DL}	2.00 V to 3.00 V, Adjustable	V _{DL} -0.05	V _{DL}	V _{DL} +0.05	V	2	2
Overdischarge release voltage	V _{DU}	2.00 V to 3.40 V, Adjustable	V _{DU} ≠ V _{DL}	V _{DU} -0.10	V _{DU} +0.10	V	2	2
			V _{DU} = V _{DL}	V _{DU} -0.05	V _{DU} +0.05	V	2	2
Discharge overcurrent detection voltage	V _{DIOV}	0.05 V to 0.30 V, Adjustable	V _{DIOV} -0.015	V _{DIOV}	V _{DIOV} +0.015	V	3	2
Load short-circuiting detection voltage*2	V _{SHORT}	-	0.30	0.50	0.70	V	3	2
Charge overcurrent detection voltage	V _{CIOV}	-	-0.13	-0.1	-0.07	V	4	2
0 V BATTERY CHARGE FUNCTION								
0 V battery charge starting charger voltage	V _{0CHA}	0 V battery charging function "available"	1.2	-	-	V	11	2
0 V battery charge inhibition battery voltage	V _{0INH}	0 V battery charging function "unavailable"	-	-	0.5	V	12	2
INTERNAL RESISTANCE								
Resistance between VM pin and VDD pin	R _{VMD}	V _{DD} = 1.8 V, V _{VM} = 0 V	100	300	900	kΩ	6	3
Resistance between VM pin and VSS pin	R _{VMS}	V _{DD} = 3.5 V, V _{VM} = 1.0 V	10	20	40	kΩ	6	3
INPUT VOLTAGE								
Operating voltage between VDD pin and VSS pin	V _{DSOP1}	-	1.5	-	8	V	-	-
Operating voltage between VDD pin and VM pin	V _{DSOP2}	-	1.5	-	28	V	-	-
INPUT CURRENT								
Current consumption during operation	I _{OPE}	V _{DD} = 3.5 V, V _{VM} = 0 V	1.0	3.0	5.5	μA	5	2
Current consumption at power-down	I _{PDN}	V _{DD} = V _{VM} = 1.5 V	-	-	0.2	μA	5	2
OUTPUT RESISTANCE								
CO pin resistance "H"	R _{COH}	V _{CO} = 3.0 V, V _{DD} = 3.5 V, V _{VM} = 0 V	2.5	5	10	kΩ	7	4
CO pin resistance "L"	R _{COL}	V _{CO} = 0.5 V, V _{DD} = 4.5 V, V _{VM} = 0 V	2.5	5	10	kΩ	7	4
DO pin resistance "H"	R _{DOH}	V _{DO} = 3.0 V, V _{DD} = 3.5 V, V _{VM} = 0 V	2.5	5	10	kΩ	8	4
DO pin resistance "L"	R _{DOL}	V _{DO} = 0.5 V, V _{DD} = V _{VM} = 1.8 V	2.5	5	10	kΩ	8	4

*1. Since products are not screened at high and low temperature, the specification for this temperature range is guaranteed by design, not tested in production.

*2. In any conditions, Load short-circuiting detection voltage (V_{SHORT}) is higher than discharge overcurrent detection voltage (V_{DIOV}).

2. Except Detection Delay Time (–40°C to +85°C*1)

Table 9

(Ta = –40°C to +85°C*1 unless otherwise specified)

Item	Symbol	Condition	Min.	Typ.	Max.	Unit	Test Condition	Test Circuit
DETECTION VOLTAGE								
Overcharge detection voltage	V _{CU}	3.90 V to 4.40 V, Adjustable	V _{CU} – 0.060	V _{CU}	V _{CU} + 0.040	V	1	1
Overcharge release voltage	V _{CL}	3.80 V to 4.40 V, Adjustable	V _{CL} ≠ V _{CU}	V _{CL} – 0.08	V _{CL} + 0.065	V	1	1
			V _{CL} = V _{CU}	V _{CL} – 0.06	V _{CL} + 0.04	V	1	1
Overdischarge detection voltage	V _{DL}	2.00 V to 3.00 V, Adjustable	V _{DL} – 0.11	V _{DL}	V _{DL} + 0.13	V	2	2
Overdischarge release voltage	V _{DU}	2.00 V to 3.40 V, Adjustable	V _{DU} ≠ V _{DL}	V _{DU} – 0.15	V _{DU} + 0.19	V	2	2
			V _{DU} = V _{DL}	V _{DU} – 0.11	V _{DU} + 0.13	V	2	2
Discharge overcurrent detection voltage	V _{DIOV}	0.05 V to 0.30 V, Adjustable	V _{DIOV} – 0.021	V _{DIOV}	V _{DIOV} + 0.024	V	3	2
Load short-circuiting detection voltage*2	V _{SHORT}	–	0.16	0.50	0.84	V	3	2
Charge overcurrent detection voltage	V _{CIOV}	–	– 0.14	– 0.1	– 0.06	V	4	2
0 V BATTERY CHARGE FUNCTION								
0 V battery charge starting charger voltage	V _{0CHA}	0 V battery charging function "available"	1.7	–	–	V	11	2
0 V battery charge inhibition battery voltage	V _{0INH}	0 V battery charging function "unavailable"	–	–	0.3	V	12	2
INTERNAL RESISTANCE								
Resistance between VM pin and VDD pin	R _{VMD}	V _{DD} = 1.8 V, V _{VM} = 0 V	78	300	1310	kΩ	6	3
Resistance between VM pin and VSS pin	R _{VMS}	V _{DD} = 3.5 V, V _{VM} = 1.0 V	7.2	20	44	kΩ	6	3
INPUT VOLTAGE								
Operating voltage between VDD pin and VSS pin	V _{DSOP1}	–	1.5	–	8	V	–	–
Operating voltage between VDD pin and VM pin	V _{DSOP2}	–	1.5	–	28	V	–	–
INPUT CURRENT								
Current consumption during operation	I _{OP}	V _{DD} = 3.5 V, V _{VM} = 0 V	0.7	3.0	6.0	μA	5	2
Current consumption at power-down	I _{PDN}	V _{DD} = V _{VM} = 1.5 V	–	–	0.3	μA	5	2
OUTPUT RESISTANCE								
CO pin resistance "H"	R _{COH}	V _{CO} = 3.0 V, V _{DD} = 3.5 V, V _{VM} = 0 V	1.2	5	15	kΩ	7	4
CO pin resistance "L"	R _{COL}	V _{CO} = 0.5 V, V _{DD} = 4.5 V, V _{VM} = 0 V	1.2	5	15	kΩ	7	4
DO pin resistance "H"	R _{DOH}	V _{DO} = 3.0 V, V _{DD} = 3.5 V, V _{VM} = 0 V	1.2	5	15	kΩ	8	4
DO pin resistance "L"	R _{DOL}	V _{DO} = 0.5 V, V _{DD} = V _{VM} = 1.8 V	1.2	5	15	kΩ	8	4

*1. Since products are not screened at high and low temperature, the specification for this temperature range is guaranteed by design, not tested in production.

*2. In any conditions, Load short-circuiting detection voltage (V_{SHORT}) is higher than discharge overcurrent detection voltage (V_{DIOV}).

3. Detection Delay Time

- (1) S-8211CAA, S-8211CAH, S-8211CAI, S-8211CAJ, S-8211CAK, S-8211CAL, S-8211CAM, S-8211CAN, S-8211CAR, S-8211CAS, S-8211CAU, S-8211CAY, S-8211CAZ, S-8211CBA, S-8211CBB, S-8211CBW, S-8211CCB

Table 10

Item	Symbol	Condition	Min.	Typ.	Max.	Unit	Test Condition	Test Circuit
DELAY TIME (Ta = 25°C)								
Overcharge detection delay time	t _{CU}	–	0.96	1.2	1.4	s	9	5
Overdischarge detection delay time	t _{DL}	–	120	150	180	ms	9	5
Discharge overcurrent detection delay time	t _{DIOV}	–	7.2	9	11	ms	10	5
Load short-circuiting detection delay time	t _{SHORT}	–	240	300	360	μs	10	5
Charge overcurrent detection delay time	t _{CIOV}	–	7.2	9	11	ms	10	5
DELAY TIME (Ta = -40°C to +85°C) **1								
Overcharge detection delay time	t _{CU}	–	0.7	1.2	2.0	s	9	5
Overdischarge detection delay time	t _{DL}	–	83	150	255	ms	9	5
Discharge overcurrent detection delay time	t _{DIOV}	–	5	9	15	ms	10	5
Load short-circuiting detection delay time	t _{SHORT}	–	150	300	540	μs	10	5
Charge overcurrent detection delay time	t _{CIOV}	–	5	9	15	ms	10	5

*1. Since products are not screened at high and low temperature, the specification for this temperature range is guaranteed by design, not tested in production.

- (2) S-8211CAB, S-8211CAV

Table 11

Item	Symbol	Condition	Min.	Typ.	Max.	Unit	Test Condition	Test Circuit
DELAY TIME (Ta = 25°C)								
Overcharge detection delay time	t _{CU}	–	0.96	1.2	1.4	s	9	5
Overdischarge detection delay time	t _{DL}	–	120	150	180	ms	9	5
Discharge overcurrent detection delay time	t _{DIOV}	–	7.2	9	11	ms	10	5
Load short-circuiting detection delay time	t _{SHORT}	–	450	560	670	μs	10	5
Charge overcurrent detection delay time	t _{CIOV}	–	7.2	9	11	ms	10	5
DELAY TIME (Ta = -40°C to +85°C) **1								
Overcharge detection delay time	t _{CU}	–	0.7	1.2	2.0	s	9	5
Overdischarge detection delay time	t _{DL}	–	83	150	255	ms	9	5
Discharge overcurrent detection delay time	t _{DIOV}	–	5	9	15	ms	10	5
Load short-circuiting detection delay time	t _{SHORT}	–	260	560	940	μs	10	5
Charge overcurrent detection delay time	t _{CIOV}	–	5	9	15	ms	10	5

*1. Since products are not screened at high and low temperature, the specification for this temperature range is guaranteed by design, not tested in production.

(3) S-8211CAD

Table 12

Item	Symbol	Condition	Min.	Typ.	Max.	Unit	Test Condition	Test Circuit
DELAY TIME (Ta = 25°C)								
Overcharge detection delay time	t _{CU}	–	115	143	172	ms	9	5
Overdischarge detection delay time	t _{DL}	–	30	38	46	ms	9	5
Discharge overcurrent detection delay time	t _{DIOV}	–	14.5	18	22	ms	10	5
Load short-circuiting detection delay time	t _{SHORT}	–	240	300	360	μs	10	5
Charge overcurrent detection delay time	t _{CIOV}	–	7.2	9	11	ms	10	5
DELAY TIME (Ta = –40°C to +85°C) *1								
Overcharge detection delay time	t _{CU}	–	82	143	240	ms	9	5
Overdischarge detection delay time	t _{DL}	–	20	38	65	ms	9	5
Discharge overcurrent detection delay time	t _{DIOV}	–	10	18	30	ms	10	5
Load short-circuiting detection delay time	t _{SHORT}	–	150	300	540	μs	10	5
Charge overcurrent detection delay time	t _{CIOV}	–	5	9	15	ms	10	5

*1. Since products are not screened at high and low temperature, the specification for this temperature range is guaranteed by design, not tested in production.

(4) S-8211CAE, S-8211CAT, S-8211CAX, S-8211CBR, S-8211CBV

Table 13

Item	Symbol	Condition	Min.	Typ.	Max.	Unit	Test Condition	Test Circuit
DELAY TIME (Ta = 25°C)								
Overcharge detection delay time	t _{CU}	–	0.96	1.2	1.4	s	9	5
Overdischarge detection delay time	t _{DL}	–	120	150	180	ms	9	5
Discharge overcurrent detection delay time	t _{DIOV}	–	14.5	18	22	ms	10	5
Load short-circuiting detection delay time	t _{SHORT}	–	240	300	360	μs	10	5
Charge overcurrent detection delay time	t _{CIOV}	–	7.2	9	11	ms	10	5
DELAY TIME (Ta = –40°C to +85°C) *1								
Overcharge detection delay time	t _{CU}	–	0.7	1.2	2.0	s	9	5
Overdischarge detection delay time	t _{DL}	–	83	150	255	ms	9	5
Discharge overcurrent detection delay time	t _{DIOV}	–	10	18	30	ms	10	5
Load short-circuiting detection delay time	t _{SHORT}	–	150	300	540	μs	10	5
Charge overcurrent detection delay time	t _{CIOV}	–	5	9	15	ms	10	5

*1. Since products are not screened at high and low temperature, the specification for this temperature range is guaranteed by design, not tested in production.

**BATTERY PROTECTION IC FOR 1-CELL PACK
S-8211C Series**

Rev.5.4_00

(5) S-8211CAF, S-8211CAO, S-8211CAP, S-8211CAQ, S-8211CBD, S-8211CBO

Table 14

Item	Symbol	Condition	Min.	Typ.	Max.	Unit	Test Condition	Test Circuit
DELAY TIME (Ta = 25°C)								
Overcharge detection delay time	t _{CU}	–	0.96	1.2	1.4	s	9	5
Overdischarge detection delay time	t _{DL}	–	30	38	46	ms	9	5
Discharge overcurrent detection delay time	t _{DIOV}	–	7.2	9	11	ms	10	5
Load short-circuiting detection delay time	t _{SHORT}	–	240	300	360	μs	10	5
Charge overcurrent detection delay time	t _{CIOV}	–	7.2	9	11	ms	10	5
DELAY TIME (Ta = -40°C to +85°C) *1								
Overcharge detection delay time	t _{CU}	–	0.7	1.2	2.0	s	9	5
Overdischarge detection delay time	t _{DL}	–	20	38	65	ms	9	5
Discharge overcurrent detection delay time	t _{DIOV}	–	5	9	15	ms	10	5
Load short-circuiting detection delay time	t _{SHORT}	–	150	300	540	μs	10	5
Charge overcurrent detection delay time	t _{CIOV}	–	5	9	15	ms	10	5

*1. Since products are not screened at high and low temperature, the specification for this temperature range is guaranteed by design, not tested in production.

(6) S-8211CAW

Table 15

Item	Symbol	Condition	Min.	Typ.	Max.	Unit	Test Condition	Test Circuit
DELAY TIME (Ta = 25°C)								
Overcharge detection delay time	t _{CU}	–	0.96	1.2	1.4	s	9	5
Overdischarge detection delay time	t _{DL}	–	120	150	180	ms	9	5
Discharge overcurrent detection delay time	t _{DIOV}	–	3.6	4.5	5.4	ms	10	5
Load short-circuiting detection delay time	t _{SHORT}	–	240	300	360	μs	10	5
Charge overcurrent detection delay time	t _{CIOV}	–	7.2	9	11	ms	10	5
DELAY TIME (Ta = -40°C to +85°C) *1								
Overcharge detection delay time	t _{CU}	–	0.7	1.2	2.0	s	9	5
Overdischarge detection delay time	t _{DL}	–	83	150	255	ms	9	5
Discharge overcurrent detection delay time	t _{DIOV}	–	2.5	4.5	7.7	ms	10	5
Load short-circuiting detection delay time	t _{SHORT}	–	150	300	540	μs	10	5
Charge overcurrent detection delay time	t _{CIOV}	–	5	9	15	ms	10	5

*1. Since products are not screened at high and low temperature, the specification for this temperature range is guaranteed by design, not tested in production.

(7) S-8211CBN

Table 16

Item	Symbol	Condition	Min.	Typ.	Max.	Unit	Test Condition	Test Circuit
DELAY TIME (Ta = 25°C)								
Overcharge detection delay time	t _{CU}	–	458	573	687	ms	9	5
Overdischarge detection delay time	t _{DL}	–	120	150	180	ms	9	5
Discharge overcurrent detection delay time	t _{DIOV}	–	3.6	4.5	5.4	ms	10	5
Load short-circuiting detection delay time	t _{SHORT}	–	240	300	360	μs	10	5
Charge overcurrent detection delay time	t _{CIOV}	–	3.6	4.5	5.4	ms	10	5
DELAY TIME (Ta = -40°C to +85°C) *1								
Overcharge detection delay time	t _{CU}	–	334	573	955	ms	9	5
Overdischarge detection delay time	t _{DL}	–	83	150	255	ms	9	5
Discharge overcurrent detection delay time	t _{DIOV}	–	2.5	4.5	7.7	ms	10	5
Load short-circuiting detection delay time	t _{SHORT}	–	150	300	540	μs	10	5
Charge overcurrent detection delay time	t _{CIOV}	–	2.5	4.5	7.7	ms	10	5

*1. Since products are not screened at high and low temperature, the specification for this temperature range is guaranteed by design, not tested in production.

■ Test Circuits

Caution Unless otherwise specified, the output voltage levels “H” and “L” at CO pin (V_{CO}) and DO pin (V_{DO}) are judged by the threshold voltage (1.0 V) of the N-channel FET. Judge the CO pin level with respect to V_{VM} and the DO pin level with respect to V_{SS} .

(1) Overcharge Detection Voltage, Overcharge Release Voltage (Test Condition 1, Test Circuit 1)

Overcharge detection voltage (V_{CU}) is defined as the voltage between the VDD pin and VSS pin at which V_{CO} goes from “H” to “L” when the voltage V_1 is gradually increased from the starting condition of $V_1 = 3.5$ V. Overcharge release voltage (V_{CL}) is defined as the voltage between the VDD pin and VSS pin at which V_{CO} goes from “L” to “H” when the voltage V_1 is then gradually decreased. Overcharge hysteresis voltage (V_{HC}) is defined as the difference between overcharge detection voltage (V_{CU}) and overcharge release voltage (V_{CL}).

(2) Overdischarge Detection Voltage, Overdischarge Release Voltage (Test Condition 2, Test Circuit 2)

Overdischarge detection voltage (V_{DL}) is defined as the voltage between the VDD pin and VSS pin at which V_{DO} goes from “H” to “L” when the voltage V_1 is gradually decreased from the starting condition of $V_1 = 3.5$ V, $V_2 = 0$ V. Overdischarge release voltage (V_{DU}) is defined as the voltage between the VDD pin and VSS pin at which V_{DO} goes from “L” to “H” when the voltage V_1 is then gradually increased. Overdischarge hysteresis voltage (V_{HD}) is defined as the difference between overdischarge release voltage (V_{DU}) and overdischarge detection voltage (V_{DL}).

(3) Discharge Overcurrent Detection Voltage (Test Condition 3, Test Circuit 2)

Discharge overcurrent detection voltage (V_{DIOV}) is defined as the voltage between the VM pin and VSS pin whose delay time for changing V_{DO} from “H” to “L” lies between the minimum and the maximum value of discharge overcurrent delay time when the voltage V_2 is increased rapidly (within 10 μ s) from the starting condition of $V_1 = 3.5$ V, $V_2 = 0$ V.

(4) Load Short-circuiting Detection Voltage (Test Condition 3, Test Circuit 2)

Load short-circuiting detection voltage (V_{SHORT}) is defined as the voltage between the VM pin and VSS pin whose delay time for changing V_{DO} from “H” to “L” lies between the minimum and the maximum value of load short-circuiting delay time when the voltage V_2 is increased rapidly (within 10 μ s) from the starting condition of $V_1 = 3.5$ V, $V_2 = 0$ V.

(5) Charge Overcurrent Detection Voltage (Test Condition 4, Test Circuit 2)

Charge overcurrent detection voltage (V_{CIOV}) is defined as the voltage between the VM pin and VSS pin whose delay time for changing V_{CO} from “H” to “L” lies between the minimum and the maximum value of charge overcurrent delay time when the voltage V_2 is decreased rapidly (within 10 μ s) from the starting condition of $V_1 = 3.5$ V, $V_2 = 0$ V.

(6) Operating Current Consumption (Test Condition 5, Test Circuit 2)

The operating current consumption (I_{OPE}) is the current that flows through the VDD pin (I_{DD}) under the set conditions of $V_1 = 3.5$ V and $V_2 = 0$ V (normal status).

(7) Power-down Current Consumption
(Test Condition 5, Test Circuit 2)

The power-down current consumption (I_{PDN}) is the current that flows through the VDD pin (I_{DD}) under the set condition of $V1 = V2 = 1.5$ V (overdischarge status).

(8) Resistance between VM Pin and VDD Pin
(Test Condition 6, Test Circuit 3)

The resistance between VM pin and VDD pin (R_{VMD}) is the resistance between VM pin and VDD pin under the set conditions of $V1 = 1.8$ V, $V2 = 0$ V.

(9) Resistance between VM Pin and VSS Pin
(Test Condition 6, Test Circuit 3)

The resistance between VM pin and VSS pin (R_{VMS}) is the resistance between VM pin and VSS pin under the set conditions of $V1 = 3.5$ V, $V2 = 1.0$ V.

(10) CO Pin Resistance “H”
(Test Condition 7, Test Circuit 4)

The CO pin resistance “H” (R_{COH}) is the resistance at the CO pin under the set conditions of $V1 = 3.5$ V, $V2 = 0$ V, $V3 = 3.0$ V.

(11) CO Pin Resistance “L”
(Test Condition 7, Test Circuit 4)

The CO pin resistance “L” (R_{COL}) is the resistance at the CO pin under the set conditions of $V1 = 4.5$ V, $V2 = 0$ V, $V3 = 0.5$ V.

(12) DO Pin Resistance “H”
(Test Condition 8, Test Circuit 4)

The DO pin H resistance (R_{DOH}) is the resistance at the DO pin under the set conditions of $V1 = 3.5$ V, $V2 = 0$ V, $V4 = 3.0$ V.

(13) DO Pin Resistance “L”
(Test Condition 8, Test Circuit 4)

The DO pin L resistance (R_{DOL}) is the resistance at the DO pin under the set conditions of $V1 = 1.8$ V, $V2 = 0$ V, $V4 = 0.5$ V.

(14) Overcharge Detection Delay Time
(Test Condition 9, Test Circuit 5)

The overcharge detection delay time (t_{CU}) is the time needed for V_{CO} to change from “H” to “L” just after the voltage $V1$ momentarily increases (within 10 μ s) from overcharge detection voltage (V_{CU}) -0.2 V to overcharge detection voltage (V_{CU}) $+0.2$ V under the set condition of $V2 = 0$ V.

(15) Overdischarge Detection Delay Time
(Test Condition 9, Test Circuit 5)

The overdischarge detection delay time (t_{DL}) is the time needed for V_{DO} to change from “H” to “L” just after the voltage $V1$ momentarily decreases (within 10 μ s) from overdischarge detection voltage (V_{DL}) $+0.2$ V to overdischarge detection voltage (V_{DL}) -0.2 V under the set condition of $V2 = 0$ V.

**(16) Discharge Overcurrent Detection Delay Time
(Test Condition 10, Test Circuit 5)**

Discharge overcurrent detection delay time (t_{DIOV}) is the time needed for V_{DO} to go to "L" after the voltage V_2 momentarily increases (within 10 μ s) from 0 V to 0.35 V under the set conditions of $V_1 = 3.5$ V, $V_2 = 0$ V.

**(17) Load Short-circuiting Detection Delay Time
(Test Condition 10, Test Circuit 5)**

Load short-circuiting detection delay time (t_{SHORT}) is the time needed for V_{DO} to go to "L" after the voltage V_2 momentarily increases (within 10 μ s) from 0 V to 1.6 V under the set conditions of $V_1 = 3.5$ V, $V_2 = 0$ V.

**(18) Charge Overcurrent Detection Delay Time
(Test Condition 10, Test Circuit 5)**

Charge overcurrent detection delay time (t_{CIOV}) is the time needed for V_{CO} to go to "L" after the voltage V_2 momentarily decreases (within 10 μ s) from 0 V to -0.3 V under the set conditions of $V_1 = 3.5$ V, $V_2 = 0$ V.

**(19) 0 V Battery Charge Starting Charger Voltage (Products with 0 V Battery Charging Function Is "Available")
(Test Condition 11, Test Circuit 2)**

The 0 V charge starting charger voltage (V_{0CHA}) is defined as the voltage between the VDD pin and VM pin at which V_{CO} goes to "H" ($V_{VM} + 0.1$ V or higher) when the voltage V_2 is gradually decreased from the starting condition of $V_1 = V_2 = 0$ V.

**(20) 0 V Battery Charge Inhibition Battery Voltage (Products with 0 V Battery Charging Function Is "Unavailable")
(Test Condition 12, Test Circuit 2)**

The 0 V charge inhibition charger voltage (V_{0INH}) is defined as the voltage between the VDD pin and VSS pin at which V_{CO} goes to "H" ($V_{VM} + 0.1$ V or higher) when the voltage V_1 is gradually increased from the starting conditions of $V_1 = 0$ V, $V_2 = -4$ V.

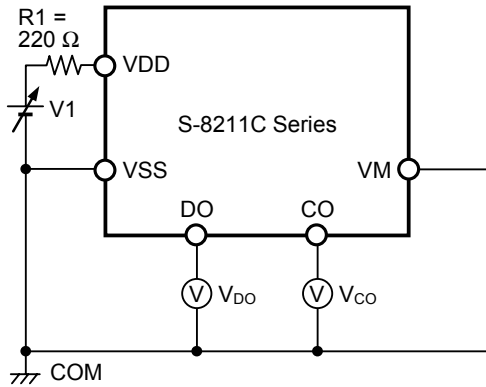

Figure 5 Test Circuit 1

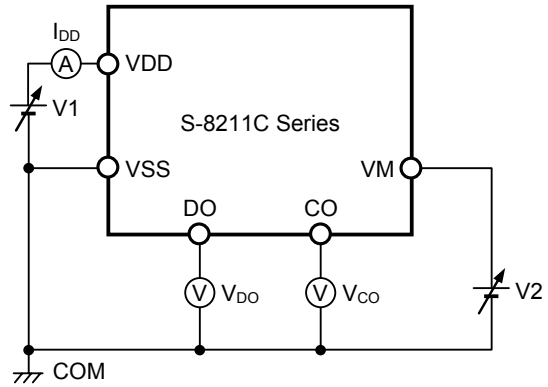

Figure 6 Test Circuit 2

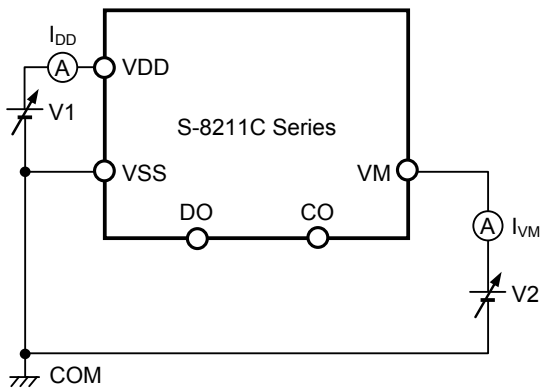

Figure 7 Test Circuit 3

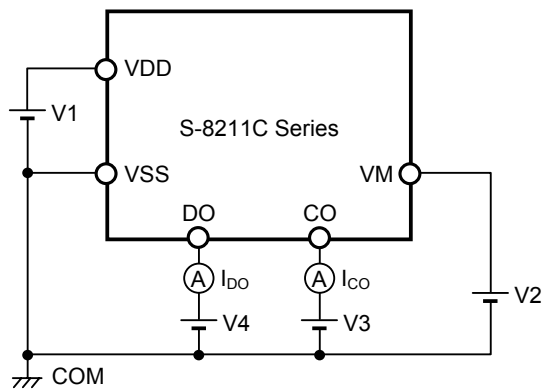

Figure 8 Test Circuit 4

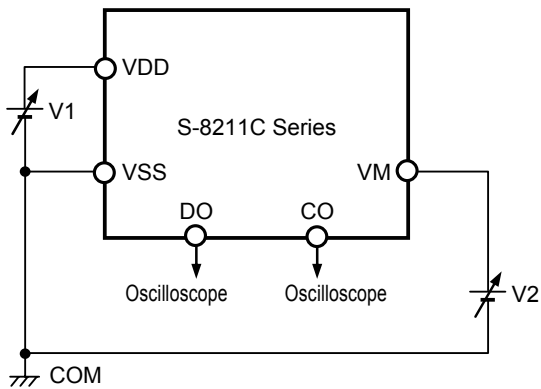

Figure 9 Test Circuit 5

■ Operation

Remark Refer to the “■ Battery Protection IC Connection Example”.

1. Normal Status

This IC monitors the voltage of the battery connected between the VDD pin and VSS pin and the voltage difference between the VM pin and VSS pin to control charging and discharging. When the battery voltage is in the range from overdischarge detection voltage (V_{DL}) to overcharge detection voltage (V_{CU}), and the VM pin voltage is in the range from the charge overcurrent detection voltage (V_{CIOV}) to discharge overcurrent detection voltage (V_{DIOV}), the IC turns both the charging and discharging control FETs on. This condition is called the normal status, and in this condition charging and discharging can be carried out freely.

The resistance (R_{VMD}) between the VM pin and VDD pin, and the resistance (R_{VMS}) between the VM pin and VSS pin are not connected in the normal status.

Caution When the battery is connected for the first time, discharging may not be enabled. In this case, Short the VM pin and VSS pin, or Set the VM pin's voltage at the level of the charge overcurrent detection voltage (V_{CIOV}) or more and the discharge overcurrent detection voltage (V_{DIOV}) or less by connecting the charger The IC returns to the normal status.

2. Overcharge Status

When the battery voltage becomes higher than overcharge detection voltage (V_{CU}) during charging in the normal status and detection continues for the overcharge detection delay time (t_{CU}) or longer, the S-8211C Series turns the charging control FET off to stop charging. This condition is called the overcharge status.

The resistance (R_{VMD}) between the VM pin and VDD pin, and the resistance (R_{VMS}) between the VM pin and VSS pin are not connected in the overcharge status.

The overcharge status is released in the following two cases ((1) and (2)).

- (1) In the case that the VM pin voltage is higher than or equal to the charge overcurrent detection voltage (V_{CIOV}), and is lower than the discharge overcurrent detection voltage (V_{DIOV}), S-8211C Series releases the overcharge status when the battery voltage falls below the overcharge release voltage (V_{CL}).
- (2) In the case that the VM pin voltage is higher than or equal to the discharge overcurrent detection voltage (V_{DIOV}), S-8211C Series releases the overcharge status when the battery voltage falls below the overcharge detection voltage (V_{CU}).

The discharge is started by connecting a load after the overcharge detection, the VM pin voltage rises more than the voltage at VSS pin due to the V_f voltage of the parasitic diode, because the discharge current flows through the parasitic diode in the charging control FET. If this VM pin voltage is higher than or equal to the discharge overcurrent detection voltage (V_{DIOV}), S-8211C Series releases the overcharge status when the battery voltage is lower than or equal to the overcharge detection voltage (V_{CU}).

For the actual application boards, changing the battery voltage and the charger voltage simultaneously enables to measure the overcharge release voltage (V_{CL}). In this case, the charger is always necessary to have the equivalent voltage level to the battery voltage. The charger keeps VM pin voltage higher than or equal to the charge overcurrent detection voltage (V_{CIOV}) and lower than or equal to the discharge overcurrent detection voltage (V_{DIOV}). S-8211C Series releases the overcharge status when the battery voltage falls below the overcharge release voltage (V_{CL}).

- Caution**
1. If the battery is charged to a voltage higher than overcharge detection voltage (V_{CU}) and the battery voltage does not fall below overcharge detection voltage (V_{CU}) even when a heavy load is connected, discharge overcurrent detection and load short-circuiting detection do not function until the battery voltage falls below overcharge detection voltage (V_{CU}). Since an actual battery has an internal impedance of tens of $m\Omega$, the battery voltage drops immediately after a heavy load that causes overcurrent is connected, and discharge overcurrent detection and load short-circuiting detection function.
 2. When a charger is connected after overcharge detection, the overcharge status is not released even if the battery voltage is below overcharge release voltage (V_{CL}). The overcharge status is released when the VM pin voltage goes over the charge overcurrent detection voltage (V_{CIOV}) by removing the charger.

3. Overdischarge Status

When the battery voltage falls below overdischarge detection voltage (V_{DL}) during discharging in the normal status and the detection continues for the overdischarge detection delay time (t_{DL}) or longer, the S-8211C Series turns the discharging control FET off to stop discharging. This condition is called the overdischarge status. Under the overdischarge status, the VM pin voltage is pulled up by the resistor between the VM pin and VDD pin in the IC (R_{VMD}). When voltage difference between the VM pin and VDD pin then is 1.3 V (Typ.) or lower, the current consumption is reduced to the power-down current consumption (I_{PDN}). This condition is called the power-down status.

The resistance (R_{VMS}) between the VM pin and VSS pin is not connected in the power-down status and the overdischarge status.

The power-down status is released when a charger is connected and the voltage difference between the VM pin and VDD pin becomes 1.3 V (typ.) or higher.

When a battery in the overdischarge status is connected to a charger and provided that the VM pin voltage is lower than -0.7 V (Typ.), the S-8211C Series releases the overdischarge status and turns the discharging FET on when the battery voltage reaches overdischarge detection voltage (V_{DL}) or higher.

When a battery in the overdischarge status is connected to a charger and provided that the VM pin voltage is not lower than -0.7 V (Typ.), the S-8211C Series releases the overdischarge status when the battery voltage reaches overdischarge release voltage (V_{DU}) or higher.

4. Discharge Overcurrent Status (Discharge Overcurrent, Load Short-circuiting)

When a battery in the normal status is in the status where the voltage of the VM pin is equal to or higher than the discharge overcurrent detection voltage because the discharge current is higher than the specified value and the status lasts for the discharge overcurrent detection delay time, the discharge control FET is turned off and discharging is stopped. This status is called the discharge overcurrent status.

In the discharge overcurrent status, the VM pin and VSS pin are shorted by the resistor between VM pin and VSS pin (R_{VMS}) in the IC. However, the voltage of the VM pin is at the V_{DD} potential due to the load as long as the load is connected. When the load is disconnected, the VM pin returns to the V_{SS} potential.

This IC detects the status when the impedance between the EB+ pin and EB- pin (Refer to the **Figure 14**) increases and is equal to the impedance that enables automatic restoration and the voltage at the VM pin returns to discharge overcurrent detection voltage (V_{DIOV}) or lower, the discharge overcurrent status is restored to the normal status.

Even if the connected impedance is smaller than automatic restoration level, the S-8211C Series will be restored to the normal status from discharge overcurrent detection status when the voltage at the VM pin becomes the discharge overcurrent detection voltage (V_{DIOV}) or lower by connecting the charger.

The resistance (R_{VMD}) between the VM pin and VDD pin is not connected in the discharge overcurrent detection status.

5. Charge Overcurrent Status

When a battery in the normal status is in the status where the voltage of the VM pin is lower than the charge overcurrent detection voltage because the charge current is higher than the specified value and the status lasts for the charge overcurrent detection delay time, the charge control FET is turned off and charging is stopped. This status is called the charge overcurrent status.

This IC will be restored to the normal status from the charge overcurrent status when, the voltage at the VM pin returns to charge overcurrent detection voltage (V_{CIOV}) or higher by removing the charger.

The charge overcurrent detection function does not work in the overdischarge status.

The resistance (R_{VMD}) between the VM pin and VDD pin, and the resistance (R_{VMS}) between the VM pin and VSS pin are not connected in the charge overcurrent status.

6. 0 V Battery Charging Function “Available”

This function is used to recharge a connected battery whose voltage is 0 V due to self-discharge. When the 0 V battery charge starting charger voltage (V_{0CHA}) or a higher voltage is applied between the EB+ and EB- pins by connecting a charger, the charging control FET gate is fixed to the VDD pin voltage.

When the voltage between the gate and source of the charging control FET becomes equal to or higher than the turn-on voltage due to the charger voltage, the charging control FET is turned on to start charging. At this time, the discharging control FET is off and the charging current flows through the internal parasitic diode in the discharging control FET. When the battery voltage becomes equal to or higher than overdischarge release voltage (V_{DU}), the S-8211C Series enters the normal status.

- Caution**
1. Some battery providers do not recommend charging for a completely self-discharged battery. Please ask the battery provider to determine whether to enable or inhibit the 0 V battery charging function.
 2. The 0 V battery charge function has higher priority than the charge overcurrent detection function. Consequently, a product in which use of the 0 V battery charging function is enabled charges a battery forcibly and the charge overcurrent cannot be detected when the battery voltage is lower than overdischarge detection voltage (V_{DL}).

7. 0 V Battery Charging Function “Unavailable”

This function inhibits recharging when a battery that is internally short-circuited (0 V battery) is connected. When the battery voltage is the 0 V battery charge inhibition battery voltage (V_{0INH}) or lower, the charging control FET gate is fixed to the EB- pin voltage to inhibit charging. When the battery voltage is the 0 V battery charge inhibition battery voltage (V_{0INH}) or higher, charging can be performed.

- Caution** Some battery providers do not recommend charging for a completely self-discharged battery. Please ask the battery provider to determine whether to enable or inhibit the 0 V battery charging function.

8. Delay Circuit

The detection delay times are determined by dividing a clock of approximately 3.5 kHz by the counter.

Remark 1. The discharge overcurrent detection delay time (t_{DIOV}) and the load short-circuiting detection delay time (t_{SHORT}) start when the discharge overcurrent detection voltage (V_{DIOV}) is detected. When the load short-circuiting detection voltage (V_{SHORT}) is detected over the load short-circuiting detection delay time (t_{SHORT}) after the detection of discharge overcurrent detection voltage (V_{DIOV}), the S-8211C turns the discharging control FET off within t_{SHORT} from the time of detecting V_{SHORT} .

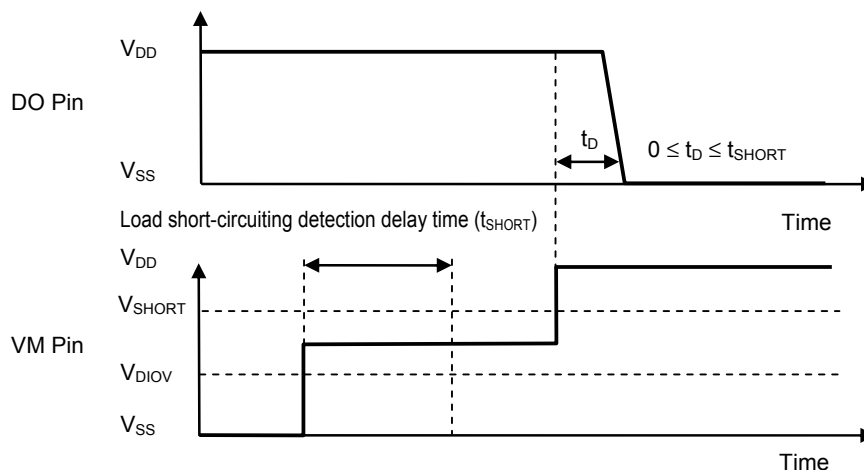
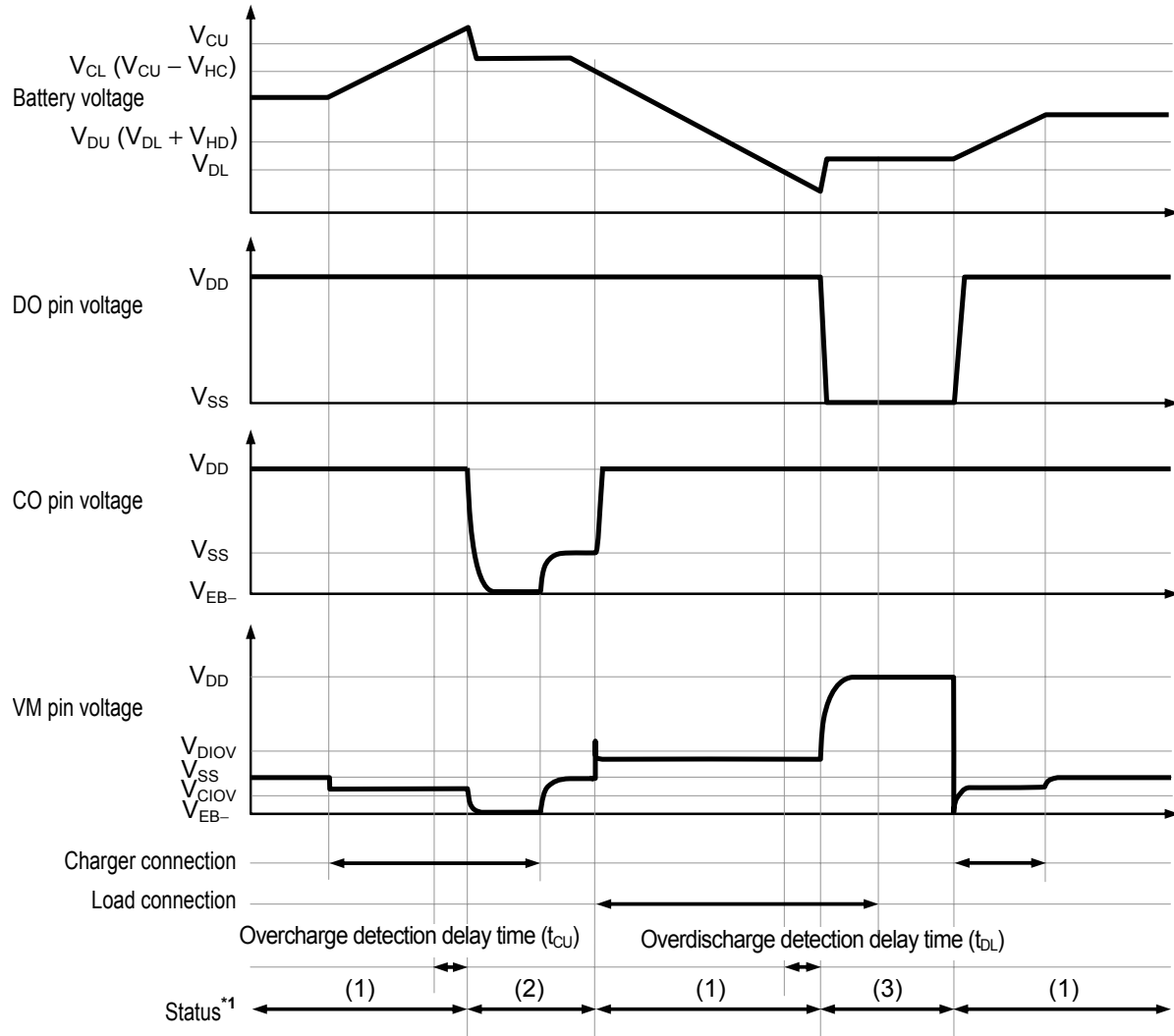

Figure 10

- When any overcurrent is detected and the overcurrent continues for longer than the overdischarge detection delay time (t_{DL}) without the load being released, the status changes to the power-down status at the point where the battery voltage falls below overdischarge detection voltage (V_{DL}).
 When the battery voltage falls below overdischarge detection voltage (V_{DL}) due to overcurrent, the S-8211C Series turns the discharging control FET off via overcurrent detection. In this case, if the recovery of the battery voltage is so slow that the battery voltage after the overdischarge detection delay time is still lower than the overdischarge detection voltage, S-8211C Series shifts to the power-down status.

■ Timing Chart

(1) Overcharge Detection, Overdischarge Detection



- *1. (1) : Normal status
 (2) : Overcharge status
 (3) : Overdischarge status

Remark The charger is assumed to charge with a constant current.

Figure 11

(2) Discharge Overcurrent Detection

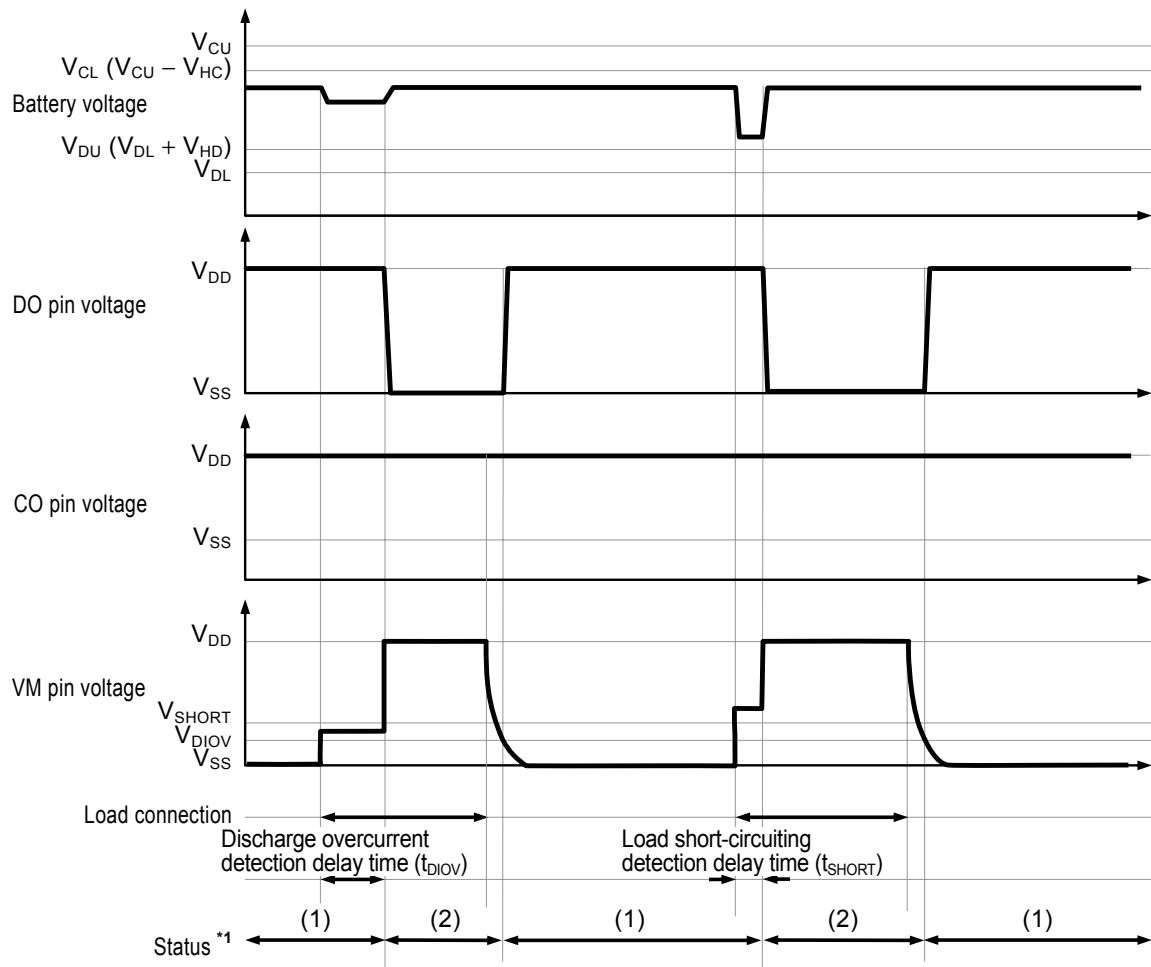

*1. (1) : Normal status
 (2) : Discharge overcurrent status

Remark The charger is assumed to charge with a constant current.

Figure 12

(3) Charge Overcurrent Detection

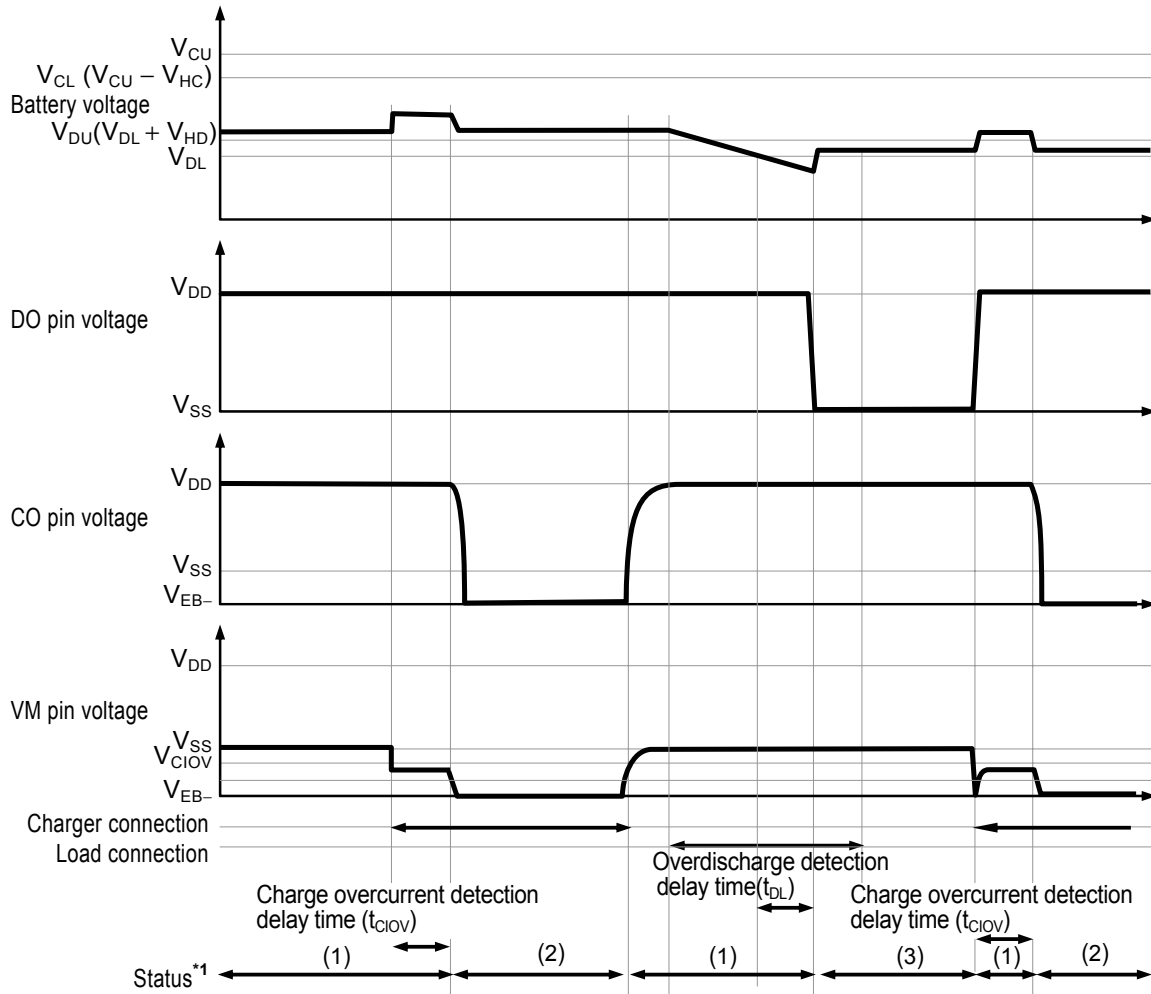

- *1. (1) : Normal status
 (2) : Charge overcurrent status
 (3) : Overdischarge status

Remark The charger is assumed to charge with a constant current.

Figure 13

■ **Battery Protection IC Connection Example**

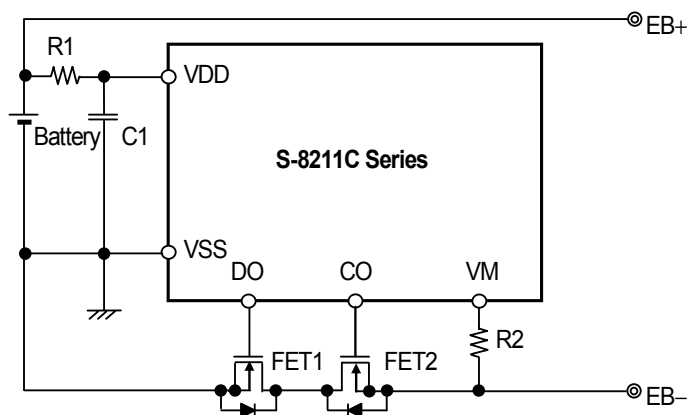

Figure 14

Table 17 Constants for External Components

Symbol	Part	Purpose	Typ.	Min.	Max.	Remark
FET1	N-channel MOS FET	Discharge control	-	-	-	Threshold voltage \leq Overdischarge detection voltage ^{*1} Gate to source withstanding voltage \geq Charger voltage ^{*2}
FET2	N-channel MOS FET	Charge control	-	-	-	Threshold voltage \leq Overdischarge detection voltage ^{*1} Gate to source withstanding voltage \geq Charger voltage ^{*2}
R1	Resistor	ESD protection, For power fluctuation	220 Ω	100 Ω	330 Ω	Resistance should be as small as possible to avoid lowering the overcharge detection accuracy due to current consumption. ^{*3}
C1	Capacitor	For power fluctuation	0.1 μF	0.022 μF	1.0 μF	Connect a capacitor of 0.022 μF or higher between VDD pin and VSS pin. ^{*4}
R2	Resistor	Protection for reverse connection of a charger	2 k Ω	300 Ω	2 k Ω	Select as large a resistance as possible to prevent current when a charger is connected in reverse. ^{*5}

- *1. If the threshold voltage of an FET is low, the FET may not cut the charging current. If an FET with a threshold voltage equal to or higher than the overdischarge detection voltage is used, discharging may be stopped before overdischarge is detected.
- *2. If the withstanding voltage between the gate and source is lower than the charger voltage, the FET may be destroyed.
- *3. If R1 has a high resistance, the voltage between VDD pin and VSS pin may exceed the absolute maximum rating when a charger is connected in reverse since the current flows from the charger to the IC. Insert a resistor of 100 Ω or higher as R1 for ESD protection.
- *4. If a capacitor of less than 0.022 μF is connected to C1, DO pin may oscillate when load short-circuiting is detected. Be sure to connect a capacitor of 0.022 μF or higher to C1.
- *5. If R2 has a resistance higher than 2 k Ω , the charging current may not be cut when a high-voltage charger is connected.

Caution 1. The above constants may be changed without notice.

- 2. It has not been confirmed whether the operation is normal or not in circuits other than the above example of connection. In addition, the example of connection shown above and the constant do not guarantee proper operation. Perform thorough evaluation using the actual application to set the constant.

■ Precautions

- The application conditions for the input voltage, output voltage, and load current should not exceed the package power dissipation.
- Do not apply an electrostatic discharge to this IC that exceeds the performance ratings of the built-in electrostatic protection circuit.
- SII claims no responsibility for any and all disputes arising out of or in connection with any infringement by products including this IC of patents owned by a third party.

■ **Characteristics (Typical Data)**

1. Current Consumption

(1) I_{OPE} vs. T_a

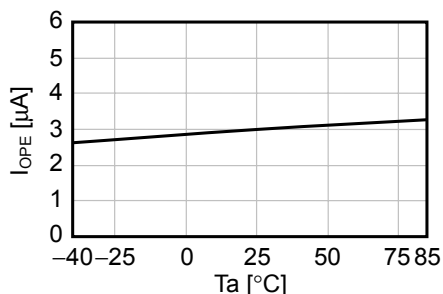

(2) I_{PDN} vs. T_a

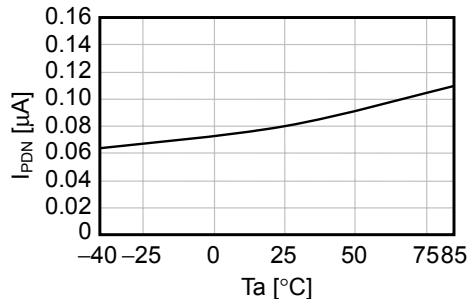

(3) I_{OPE} vs. V_{DD}

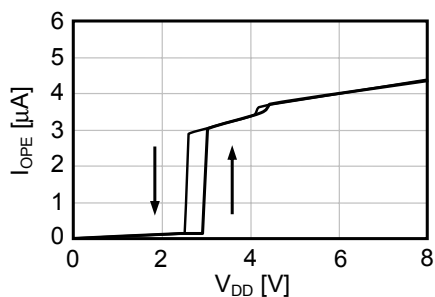

2. Overcharge Detection / Release Voltage, Overdischarge Detection / Release Voltage, Overcurrent Detection Voltage, and Delay Time

(1) V_{CU} vs. T_a

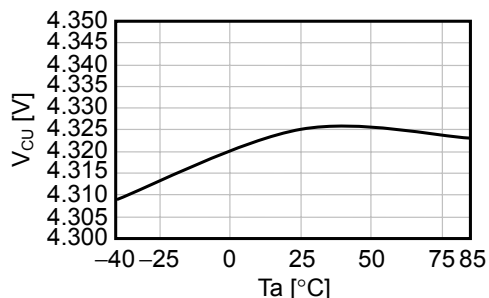

(2) V_{CL} vs. T_a

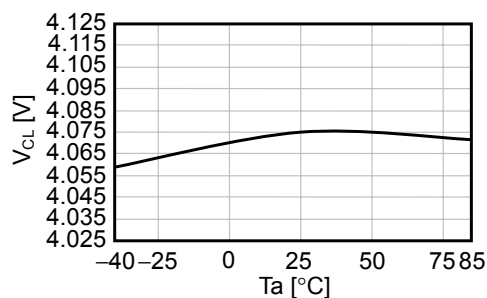

(3) V_{DU} vs. T_a

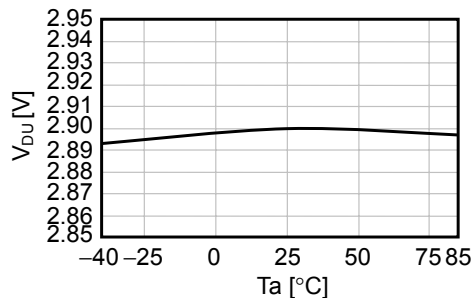

(4) V_{DL} vs. T_a

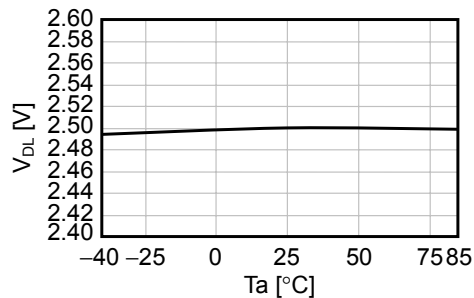

(5) t_{CU} vs. T_a

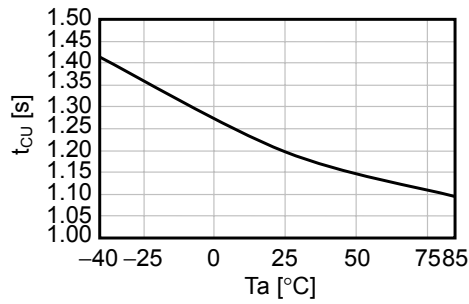

(6) t_{DL} vs. T_a

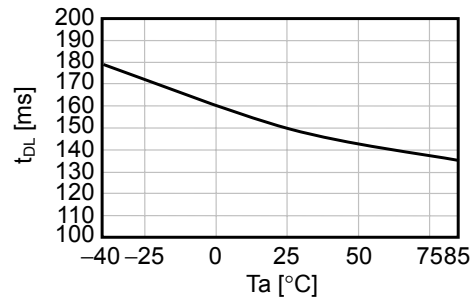

(7) V_{DIOV} vs. T_a

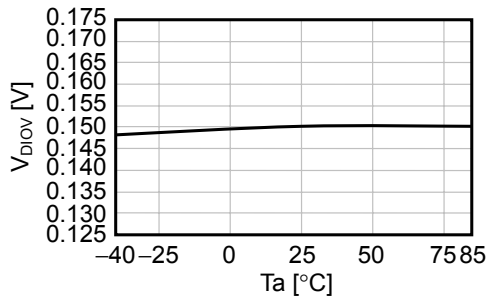

(8) t_{DIOV} vs. V_{DD}

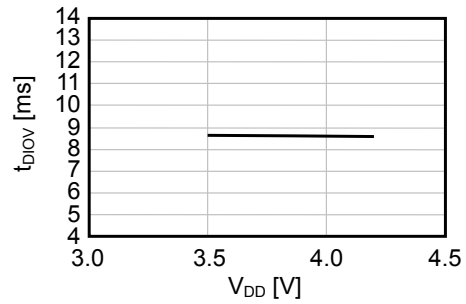

(9) t_{DIOV} vs. T_a

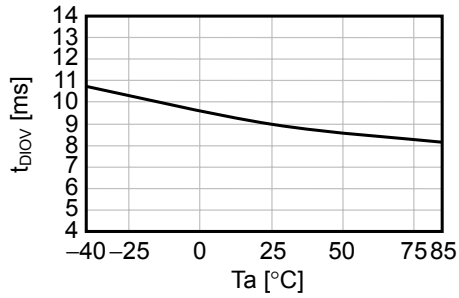

(10) V_{CIOV} vs. T_a

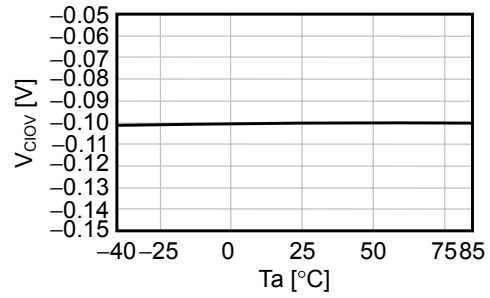

(11) t_{CIOV} vs. V_{DD}

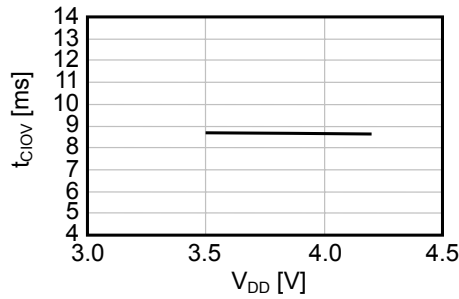

(12) t_{CIOV} vs. T_a

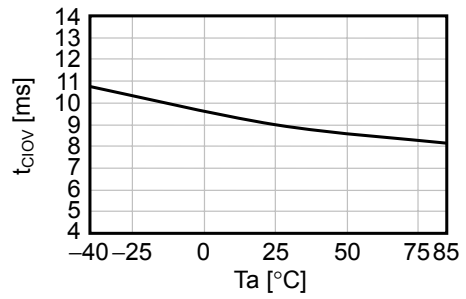

(13) V_{SHORT} vs. T_a

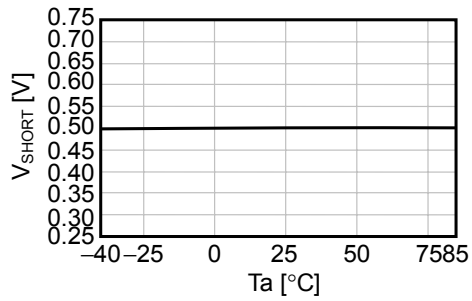

(14) t_{SHORT} vs. V_{DD}

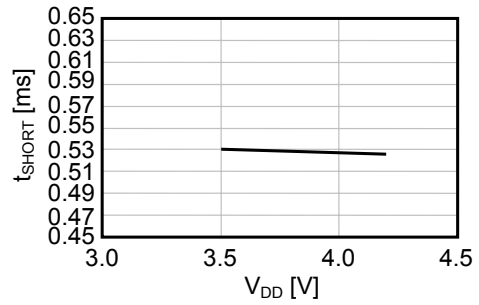

(15) t_{SHORT} vs. T_a

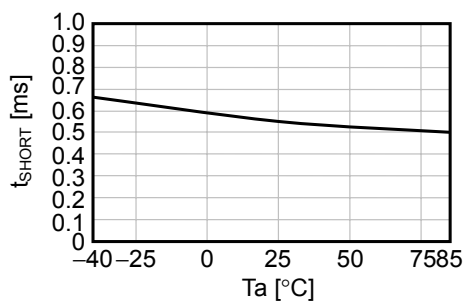

3. CO pin / DO pin

(1) I_{COH} vs. V_{CO}

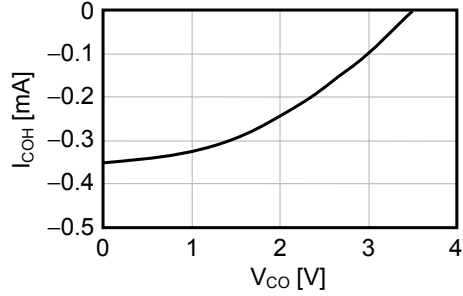

(2) I_{COL} vs. V_{CO}

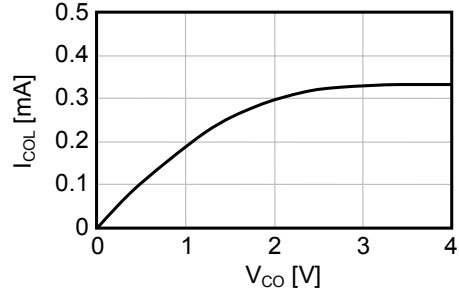

(3) I_{DOH} vs. V_{DO}

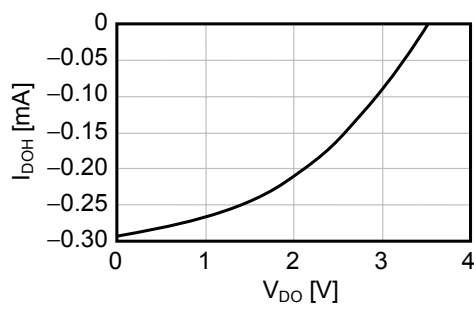

(4) I_{DOL} vs. V_{DO}

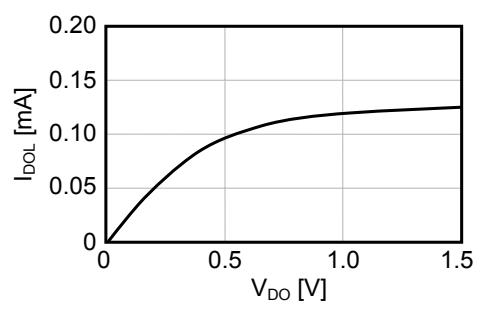

■ **Marking Specifications**

(1) SOT-23-5

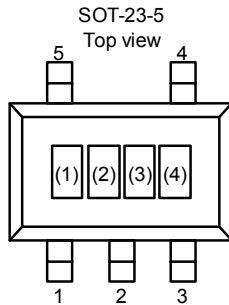

(1) to (3): Product Code (refer to **Product Name vs. Product Code**)
 (4) : Lot number

Product Name vs. Product Code

Product Name	Product Code		
	(1)	(2)	(3)
S-8211CAA-M5T1G	R	Z	A
S-8211CAB-M5T1G	R	Z	B
S-8211CAD-M5T1G	R	Z	D
S-8211CAE-M5T1G	R	Z	E
S-8211CAF-M5T1G	R	Z	F
S-8211CAH-M5T1G	R	Z	H
S-8211CAI-M5T1G	R	Z	I
S-8211CAJ-M5T1G	R	Z	J
S-8211CAK-M5T1G	R	Z	K
S-8211CAL-M5T1G	R	Z	L
S-8211CAM-M5T1G	R	Z	M
S-8211CAN-M5T1G	R	Z	N
S-8211CAO-M5T1G	R	Z	O
S-8211CAP-M5T1G	R	Z	P
S-8211CAQ-M5T1G	R	Z	Q
S-8211CAR-M5T1G	R	Z	R
S-8211CAS-M5T1G	R	Z	S
S-8211CAT-M5T1G	R	Z	T
S-8211CAU-M5T1G	R	Z	U
S-8211CAV-M5T1G	R	Z	V
S-8211CAY-M5T1G	R	Z	Y
S-8211CAZ-M5T1G	R	Z	Z
S-8211CBV-M5T1G	R	7	V

Remark Please contact our sales office for the products other than those specified above.

(2) SNT-6A

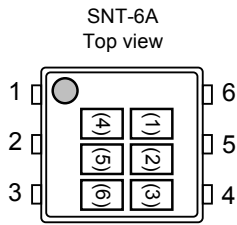

(1) to (3): Product Code (refer to **Product Name vs. Product Code**)
(4) to (6): Lot number

Product Name vs. Product Code

Product Name	Product Code		
	(1)	(2)	(3)
S-8211CAA-I6T1G	R	Z	A
S-8211CAB-I6T1G	R	Z	B
S-8211CAD-I6T1G	R	Z	D
S-8211CAE-I6T1G	R	Z	E
S-8211CAF-I6T1G	R	Z	F
S-8211CAH-I6T1G	R	Z	H
S-8211CAI-I6T1G	R	Z	I
S-8211CAJ-I6T1G	R	Z	J
S-8211CAK-I6T1G	R	Z	K
S-8211CAL-I6T1G	R	Z	L
S-8211CAM-I6T1G	R	Z	M
S-8211CAN-I6T1G	R	Z	N
S-8211CAO-I6T1G	R	Z	O
S-8211CAP-I6T1G	R	Z	P
S-8211CAQ-I6T1G	R	Z	Q
S-8211CAR-I6T1G	R	Z	R
S-8211CAS-I6T1G	R	Z	S
S-8211CAT-I6T1G	R	Z	T
S-8211CAU-I6T1G	R	Z	U
S-8211CAV-I6T1G	R	Z	V
S-8211CAW-I6T1G	R	Z	W
S-8211CAX-I6T1G	R	Z	X
S-8211CAY-I6T1G	R	Z	Y
S-8211CAZ-I6T1G	R	Z	Z
S-8211CBA-I6T1G	R	7	A
S-8211CBB-I6T1G	R	7	B
S-8211CBD-I6T1G	R	7	D
S-8211CBN-I6T1G	R	7	N
S-8211CBO-I6T1G	R	7	O
S-8211CBR-I6T1G	R	7	R
S-8211CBW-I6T1G	R	7	W
S-8211CCB-I6T1G	R	8	B

Remark Please contact our sales office for the products other than those specified above.

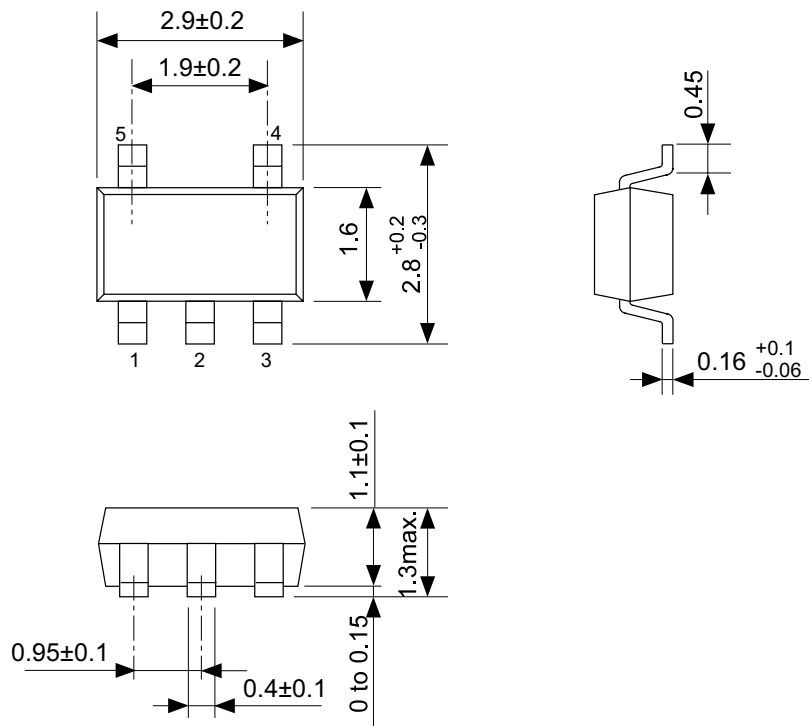

No. MP005-A-P-SD-1.2

TITLE	SOT235-A-PKG Dimensions
No.	MP005-A-P-SD-1.2
SCALE	
UNIT	mm
Seiko Instruments Inc.	

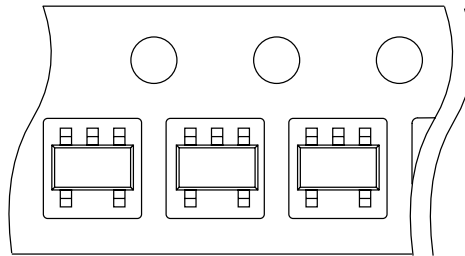
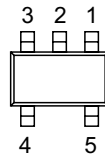
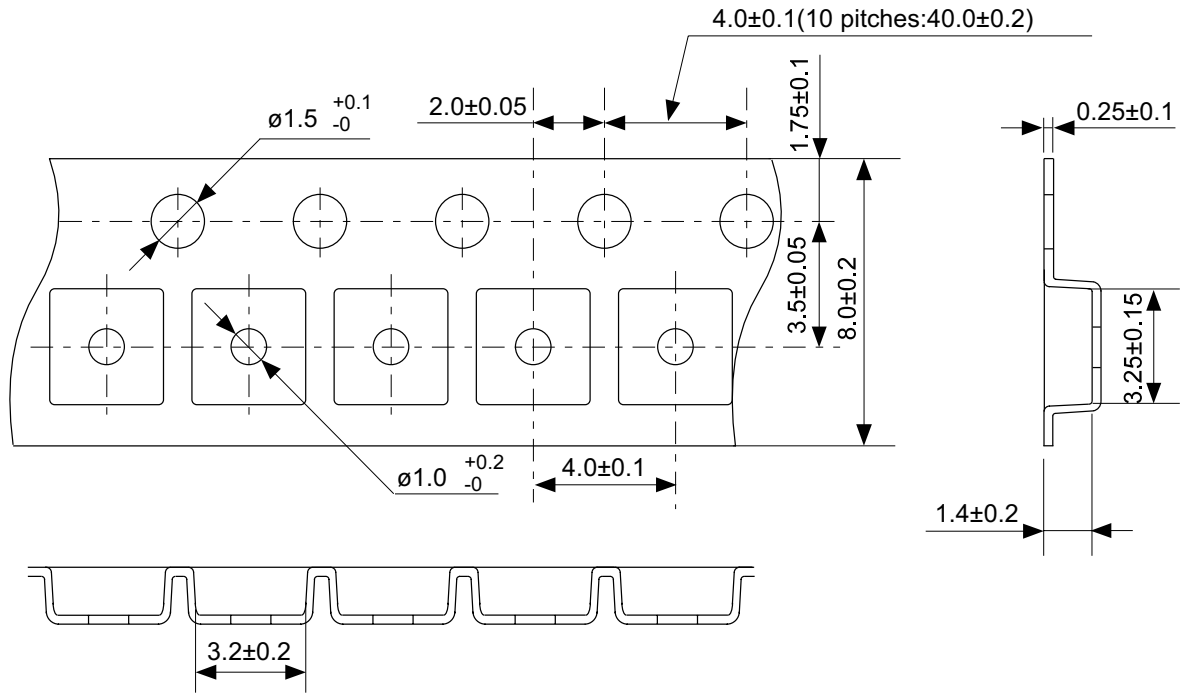

→
Feed direction

No. MP005-A-C-SD-2.1

TITLE	SOT235-A-Carrier Tape
No.	MP005-A-C-SD-2.1
SCALE	
UNIT	mm
Seiko Instruments Inc.	

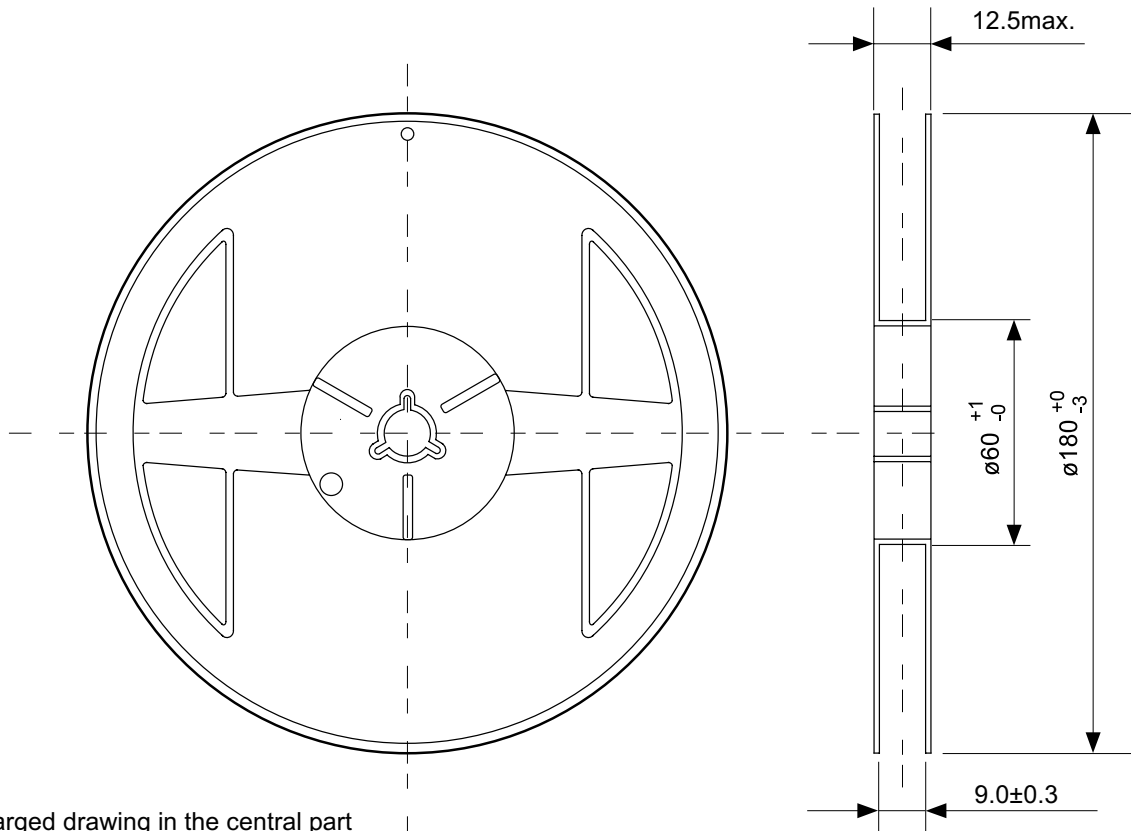

Enlarged drawing in the central part

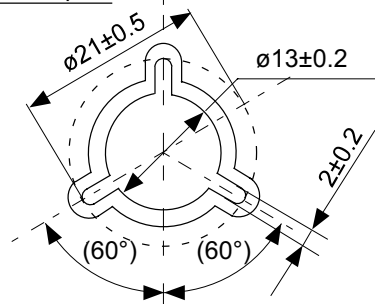

No. MP005-A-R-SD-1.1

TITLE	SOT235-A-Reel		
No.	MP005-A-R-SD-1.1		
SCALE		QTY.	3,000
UNIT	mm		
Seiko Instruments Inc.			

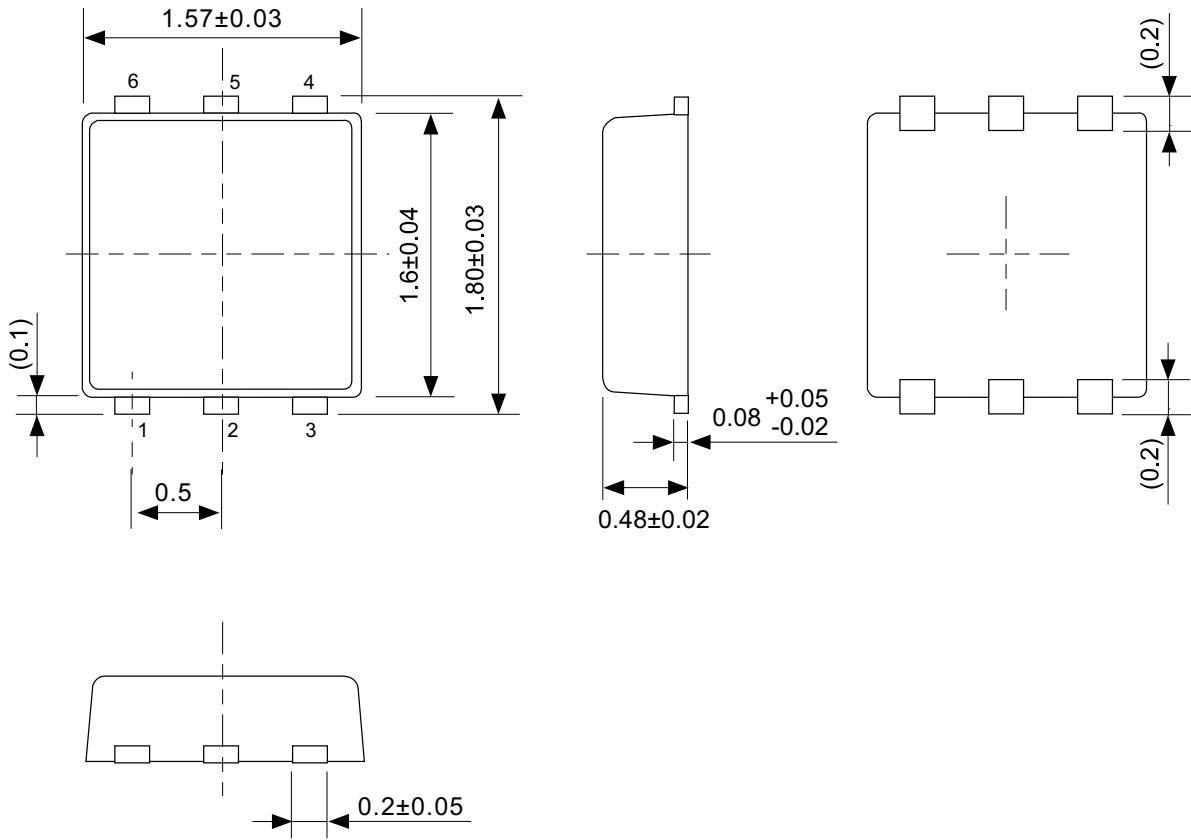

No. PG006-A-P-SD-2.0

TITLE	SNT-6A-A-PKG Dimensions
No.	PG006-A-P-SD-2.0
SCALE	
UNIT	mm
Seiko Instruments Inc.	

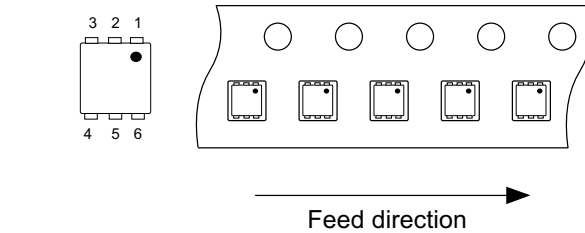
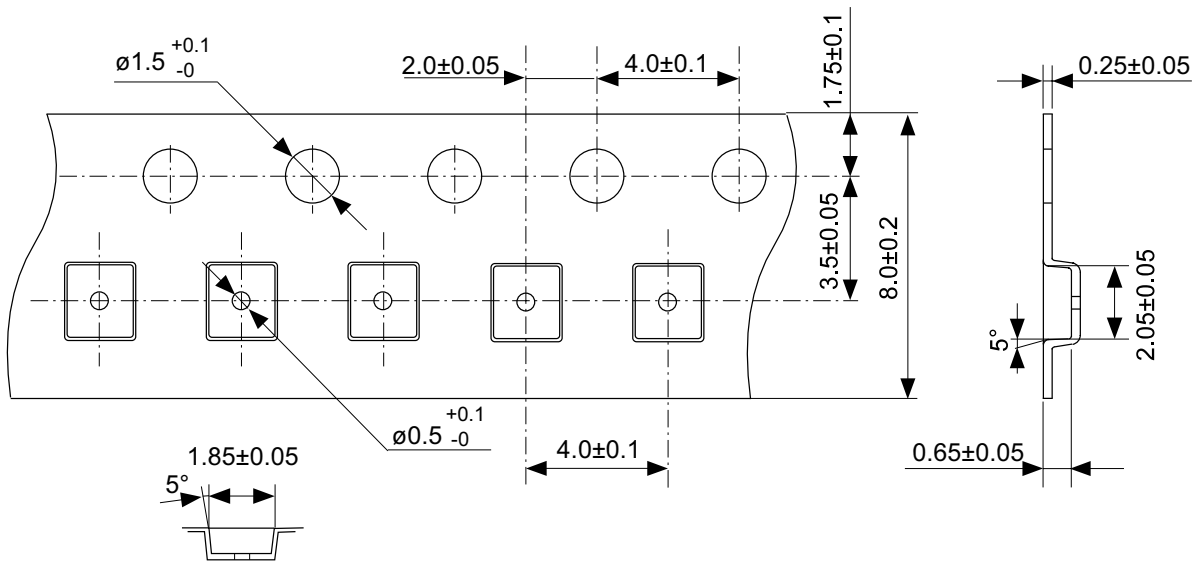

No. PG006-A-C-SD-1.0

TITLE	SNT-6A-A-Carrier Tape
No.	PG006-A-C-SD-1.0
SCALE	
UNIT	mm
Seiko Instruments Inc.	

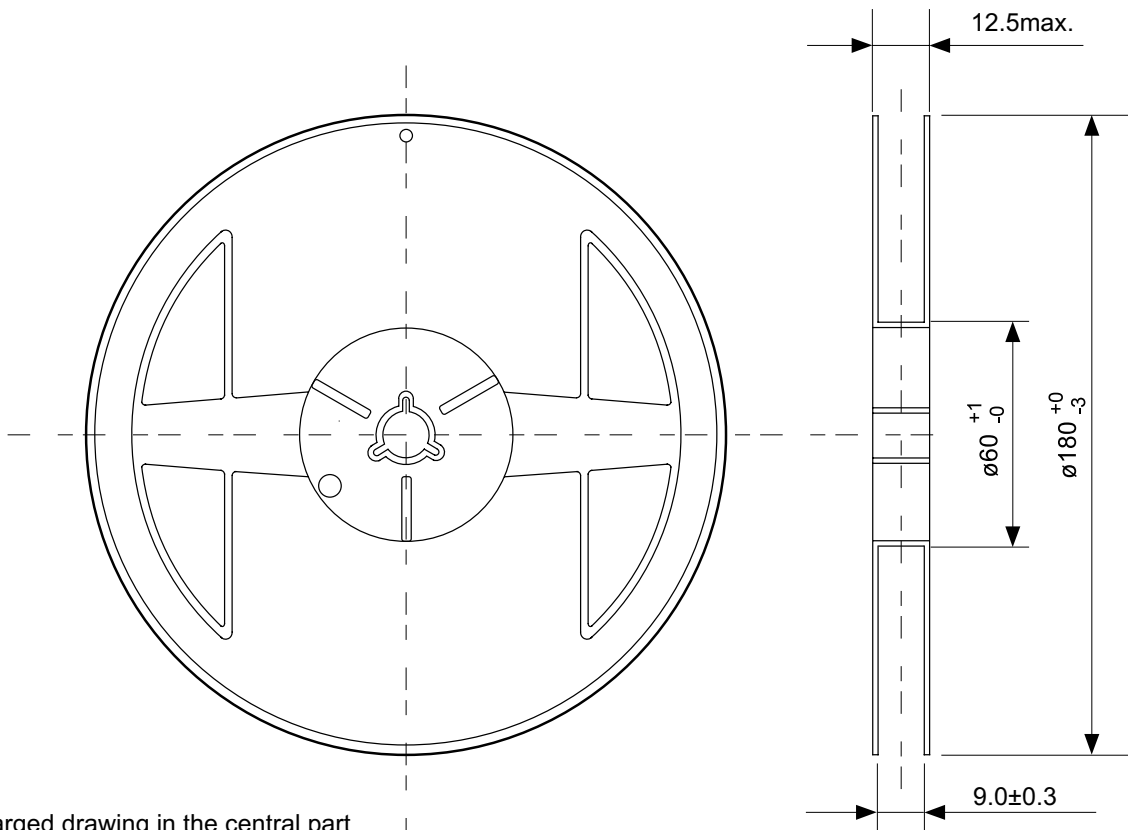

Enlarged drawing in the central part

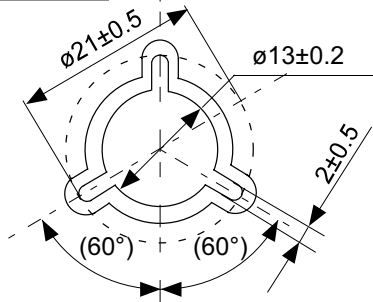

No. PG006-A-R-SD-1.0

TITLE	SNT-6A-A-Reel		
No.	PG006-A-R-SD-1.0		
SCALE		QTY.	5,000
UNIT	mm		
Seiko Instruments Inc.			

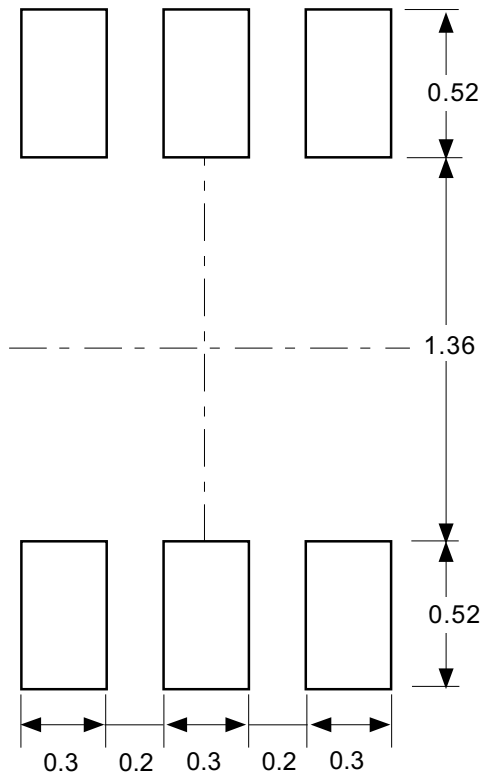

Caution Making the wire pattern under the package is possible. However, note that the package may be upraised due to the thickness made by the silk screen printing and of a solder resist on the pattern because this package does not have the standoff.

注意 パッケージ下への配線パターン形成は可能ですが、本パッケージはスタンドオフが無いので、パターン上のレジスト厚み、シルク印刷の厚みによってパッケージが持ち上がる場合がありますのでご配慮ください。

No. PG006-A-L-SD-3.0

TITLE	SNT-6A-A-Land Recommendation
No.	PG006-A-L-SD-3.0
SCALE	
UNIT	mm
Seiko Instruments Inc.	

- The information described herein is subject to change without notice.
- Seiko Instruments Inc. is not responsible for any problems caused by circuits or diagrams described herein whose related industrial properties, patents, or other rights belong to third parties. The application circuit examples explain typical applications of the products, and do not guarantee the success of any specific mass-production design.
- When the products described herein are regulated products subject to the Wassenaar Arrangement or other agreements, they may not be exported without authorization from the appropriate governmental authority.
- Use of the information described herein for other purposes and/or reproduction or copying without the express permission of Seiko Instruments Inc. is strictly prohibited.
- The products described herein cannot be used as part of any device or equipment affecting the human body, such as exercise equipment, medical equipment, security systems, gas equipment, or any apparatus installed in airplanes and other vehicles, without prior written permission of Seiko Instruments Inc.
- Although Seiko Instruments Inc. exerts the greatest possible effort to ensure high quality and reliability, the failure or malfunction of semiconductor products may occur. The user of these products should therefore give thorough consideration to safety design, including redundancy, fire-prevention measures, and malfunction prevention, to prevent any accidents, fires, or community damage that may ensue.