

NCP1232

Microprocessor Monitor

The NCP1232 is a fully-integrated processor supervisor. It provides three important functions to safeguard processor functionality: precision power on/off reset control, watchdog timer and external reset override.

On power-up, the NCP1232 holds the processor in the reset state for a minimum of 250 msec after V_{CC} is within tolerance to ensure a stable system start-up.

Microprocessor functionality is monitored by the on-board watchdog circuit. The microprocessor must provide a periodic low-going signal on the \overline{ST} input. Should the processor fail to supply this signal within the selected time-out period (150 msec, 600 msec or 1200 msec), an out-of-control processor is indicated and the NCP1232 issues a processor reset as a result.

The outputs of the NCP1232 are immediately driven active when the PB input is brought low by an external push-button switch or other electronic signal. When connected to a push-button switch, the NCP1232 provides contact debounce.

The NCP1232 is packaged in a space-saving 8-pin plastic SOIC package and requires no external components.

Features

- Precision Voltage Monitor
(Adjustable +4.5 V or +4.75 V)
- Reset Pulse Width (250 msec Min)
- No External Components
- Adjustable Watchdog Timer
(150 msec, 600 msec or 1.2 sec)
- Debounced Manual Reset Input for External Override

Applications

- Computers
- Controllers
- Intelligent Instruments
- Automotive Systems
- Critical μ P Power Monitoring



ON Semiconductor

<http://onsemi.com>



SO-8
D SUFFIX
CASE 751

MARKING DIAGRAM

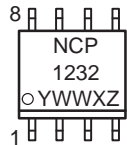

YY, Y = Year
WW = Work Week
X = Assembly ID Code
Z = Subcontractor ID Code

PIN CONNECTIONS

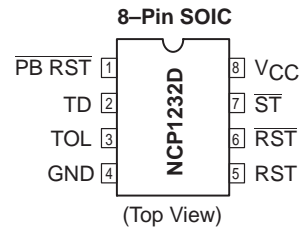

ORDERING INFORMATION

Device	Package	Shipping
NCP1232DR2	SO-8	2500 Tape & Reel

NCP1232

FUNCTIONAL BLOCK DIAGRAM

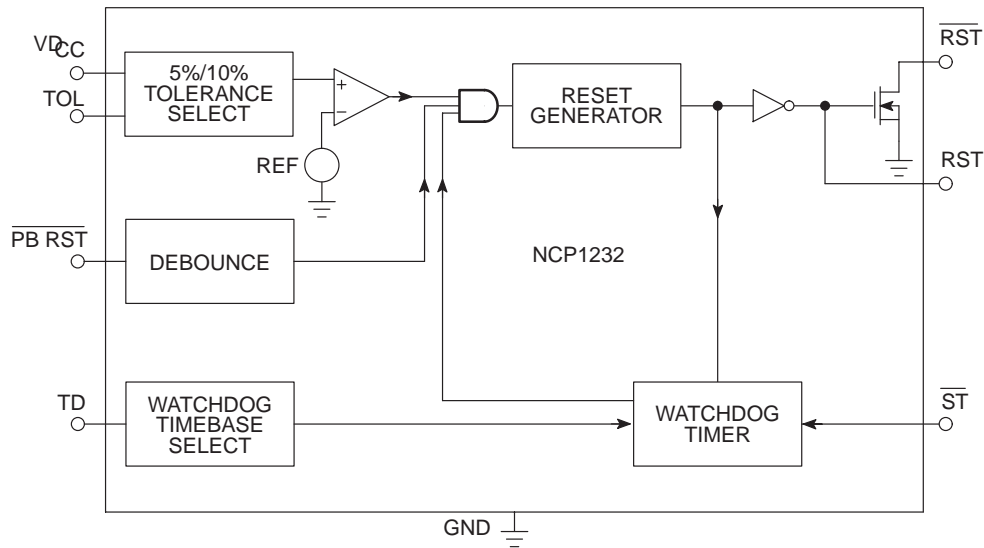

PIN DESCRIPTION

Pin No. (8-Pin SOIC)	Symbol	Description
1	$\overline{PB\ RST}$	Push-button Reset Input. A debounced active-low input that ignores pulses less than 1 msec in duration and is guaranteed to recognize inputs of 20 msec or greater.
2	TD	Time Delay Set. The watchdog time-out select input ($t_{TD} = 150$ msec for TD = 0 V, $t_{TD} = 600$ msec for TD = open, $t_{TD} = 1.2$ sec for TD = V_{CC} .)
3	TOL	Tolerance Input. Connect to GND for 5% tolerance or to V_{CC} for 10% tolerance.
4	GND	Ground.
5	RST	Reset Output (Active High) – goes active: 1. If V_{CC} falls below the selected reset voltage threshold 2. If $\overline{PB\ RST}$ is forced low 3. If \overline{ST} is not strobed within the minimum time-out period 4. During power-up
6	\overline{RST}	Reset Output (Active Low, Open Drain) – see RST.
7	\overline{ST}	Strobe Input. Input for watchdog timer.
8	V_{CC}	The +5 V Power Supply Input.

NCP1232

ABSOLUTE MAXIMUM RATINGS* Voltage on any pin (with respect to GND) –0.3 V to +5.8 V

Rating	Value	Unit
Operating Temperature Range	–40 to +85	°C
Storage Temperature Range, T_{stg}	–65 to +150	°C
Lead Temperature (Soldering, 10 sec)	+300	°C

*Stresses beyond those listed under “Absolute Maximum Ratings” may cause permanent damage to the device. These are stress ratings only, and functional operation of the device at these or any other conditions beyond those indicated in the operational sections of the specifications is not implied. Exposure to absolute maximum rating conditions for extended periods may affect device reliability.

DC ELECTRICAL CHARACTERISTICS ($T_A = T_{MIN}$ to T_{MAX} ; $V_{CC} = +4.5$ V to 5.5 V, unless otherwise specified.)

Characteristic	Symbol	Test Conditions	Min	Typ	Max	Unit
Supply Voltage	V_{CC}	–	4.5	5.0	5.5	V
\overline{ST} and $\overline{PB RST}$ Input High Level	V_{IH}	Note 1.	2.0	–	$V_{CC} + 0.3$	V
\overline{ST} and $\overline{PB RST}$ Input Low Level	V_{IL}	–	–0.3	–	+0.8	V
Input Leakage \overline{ST} , TOL	I_L	–	–1.0	–	+1.0	μ A
Output Current RST	I_{OH}	$V_{OH} = 2.4$ V	–1.0	–12	–	mA
Current RST , \overline{RST}	I_{OL}	$V_{OL} = 0.4$ V	2.0	10	–	mA
Operating Current	I_{CC}	Note 2.	–	50	200	μ A
V_{CC} 5% Trip Point (Note 3.)	V_{CCTP}	TOL = GND	4.50	4.62	4.74	V
V_{CC} 10% Trip Point (Note 3.)	V_{CCTP}	TOL = V_{CC}	4.25	4.37	4.49	V

CAPACITANCE (Note 4.) ($T_A = +25^\circ\text{C}$)

Characteristic	Symbol	Test Conditions	Min	Typ	Max	Unit
Input Capacitance \overline{ST} , TOL	C_{IN}	–	–	–	5.0	pF
Output Capacitance RST , \overline{RST}	C_{OUT}	–	–	–	7.0	pF

AC ELECTRICAL CHARACTERISTICS ($T_A = T_{MIN}$ to T_{MAX} ; $V_{CC} = +5.0$ V to $\pm 10\%$, unless otherwise specified.)

Characteristic	Symbol	Test Conditions	Min	Typ	Max	Unit
$\overline{PB RST}$ (Note 5.)	t_{PB}	Figure 3	20	–	–	msec
$\overline{PB RST}$ Delay	t_{PBD}	Figure 3	1.0	4.0	20	msec
Reset Active Time	t_{RST}	–	250	610	1000	msec
\overline{ST} Pulse Width	t_{ST}	Figure 4	20	–	–	nsec
\overline{ST} Time–out Period	t_{TD}	Figure 4 TD Pin = 0 V TD Pin = Open TD Pin = V_{CC}	62.5 250 500	150 600 1200	250 1000 2000	msec
V_{CC} Fall Time (Note 4.)	t_F	Figure 5	10	–	–	μ sec
V_{CC} Rise Time (Note 4.)	t_R	Figure 6	0	–	–	μ sec
V_{CC} Detect to RST High and \overline{RST} Low	t_{RPD}	Figure 7, V_{CC} Falling	–	–	100	nsec
V_{CC} Detect to RST High and \overline{RST} Open (Note 6.)	t_{RPU}	Figure 8, V_{CC} Rising	250	610	1000	msec

1. $\overline{PB RST}$ is internally pulled up to V_{CC} with an internal impedance of typically 40 k Ω .
2. Measured with outputs open.
3. All voltages references to GND.
4. Guaranteed by design.
5. $\overline{PB RST}$ must be held low for a minimum of 20 msec to guarantee a reset.
6. $t_R = 5 \mu$ sec.

Power Monitor

The NCP1232 detects out-of-tolerance power supply conditions and warns a processor-based system of an impending power failure. When V_{CC} is detected as below the preset level defined by TOL , the V_{CC} comparator outputs the signals RST and \overline{RST} . If TOL is connected to ground, the RST and \overline{RST} signals become active as V_{CC} falls below 4.75 volts. If TOL is connected to V_{CC} , the RST and \overline{RST} become active as V_{CC} falls below 4.5 volts. Because the processing is stopped at the last possible moment of valid V_{CC} , the RST and \overline{RST} are excellent control signals for a μP . The reset outputs will remain in their active states until V_{CC} has been continuously in-tolerance for a minimum of 250 msec allowing the power supply and μP to stabilize before \overline{RST} is released.

Push-button Reset Input

The debounced manual reset input ($\overline{PB RST}$) manually forces the reset outputs into their active states. Once $\overline{PB RST}$ has been low for a time, t_{PBD} , the push-button delay time, the reset outputs go active. The reset outputs remain in their active states for a minimum of 250 msec after $\overline{PB RST}$ rises above V_{IH} (Figure 3).

A mechanical push-button or active logic signal can drive the $\overline{PB RST}$ input. The debounced input ignores input pulses less than 1 msec and is guaranteed to recognize pulses of 20 msec or greater. No external pull-up resistor is required because the $\overline{PB RST}$ input has an internal pull-up to V_{CC} of approximately 100 μA .

Watchdog Timer

When the \overline{ST} input is not stimulated for a preset time period, the watchdog timer function forces RST and \overline{RST} signals to the active state. The preset time period is determined by the TD inputs to be 150 msec with TD connected to ground, 600 msec with TD open, or 1200 msec with TD connected to V_{CC} , typical. The watchdog timer starts timing out from the set time period as soon as RST and \overline{RST} are inactive. If a high-to-low transition occurs on the \overline{ST} input pin prior to time-out, the watchdog timer is reset and begins to time-out again. If the watchdog timer is allowed to time-out, then the RST and \overline{RST} signals are driven to the active state for 250 msec minimum (Figure 2).

The software routine that strobes \overline{ST} is critical. The code must be in a section of software that is executed regularly so the time between toggles is less than the watchdog time-out period. One common technique controls the μP I/O line from two sections of the program. The software might set the

I/O line high while operating in the foreground mode and set it low while in the background or interrupt mode. If both modes do not execute correctly, the watchdog timer issues reset pulses.

Supply Monitor Noise Sensitivity

The NCP1232 is optimized for fast response to negative-going changes in V_{DD} . Systems with an inordinate amount of electrical noise on V_{DD} (such as systems using relays), may require a 0.01 μF or 0.1 μF bypass capacitor to reduce detection sensitivity. This capacitor should be installed as close to the NCP1232 as possible to keep the capacitor lead length short.

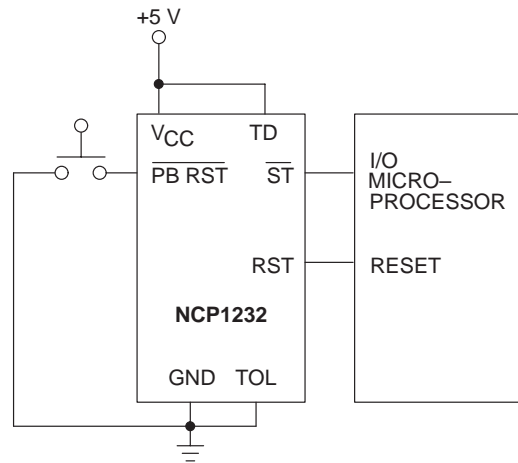

Figure 1. Push-button Reset

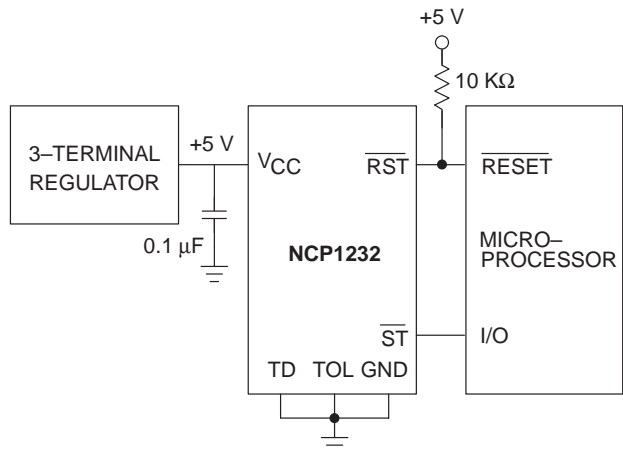

Figure 2. Watchdog Timer

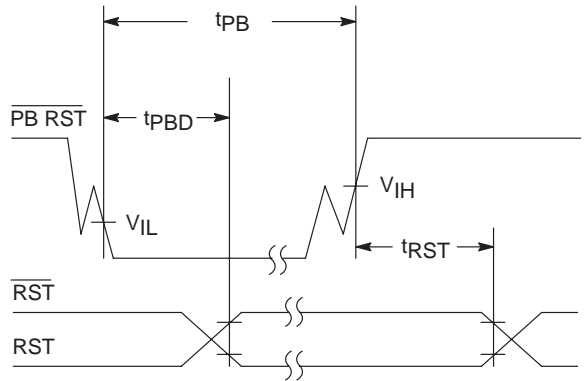

Figure 3. Push-button Reset. The debounced $\overline{\text{PB RST}}$ input ignores input pulses less than 1 msec and is guaranteed to recognized pulses of 20 msec or greater

PUSH-BUTTON RESET

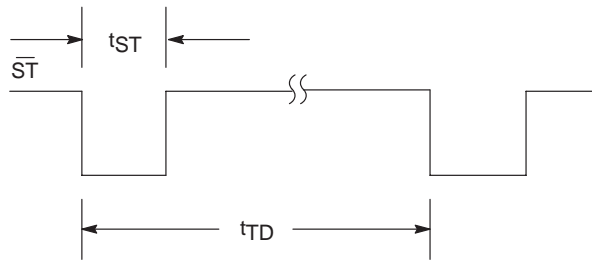

Figure 4. Strobe Input

NOTE: t_{TD} is the maximum elapsed time between $\overline{\text{ST}}$ high-to-low transitions ($\overline{\text{ST}}$ is activated by falling edges only) which will keep the watchdog timer from forcing the reset outputs active for a time of t_{RST} . t_{TD} is a function of the voltage at the TD pin, as tabulated below.

CONDITION	MIN	t_{TD} TYP	MAX
TD PIN = 0 V	62.5 msec	150 msec	250 msec
TD PIN = OPEN	250 msec	600 msec	1000 msec
TD PIN = V_{CC}	500 msec	1200 msec	2000 msec

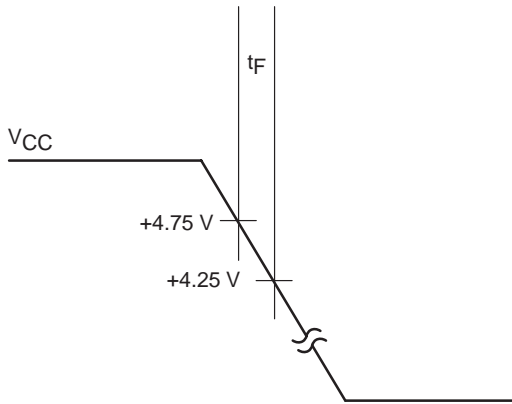

Figure 5. Power-Down Slew Rate

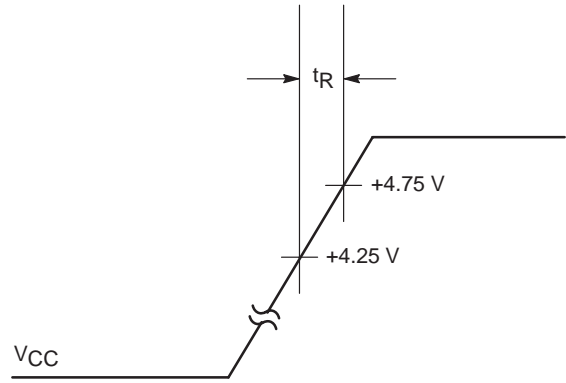

Figure 6. Power-Up Slew Rate

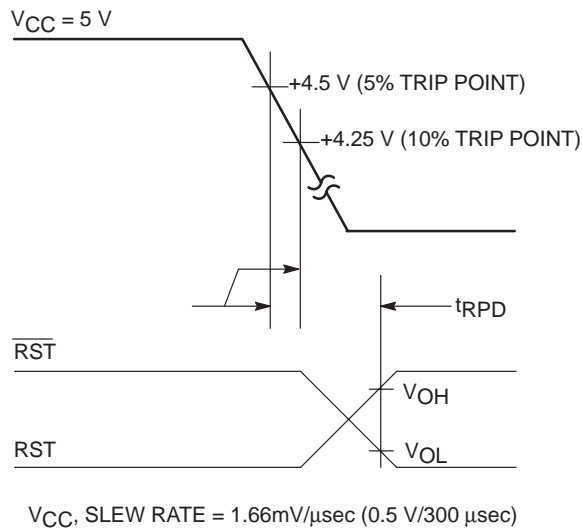

Figure 7. V_{CC} Detect Reset Output Delay (Power-Down)

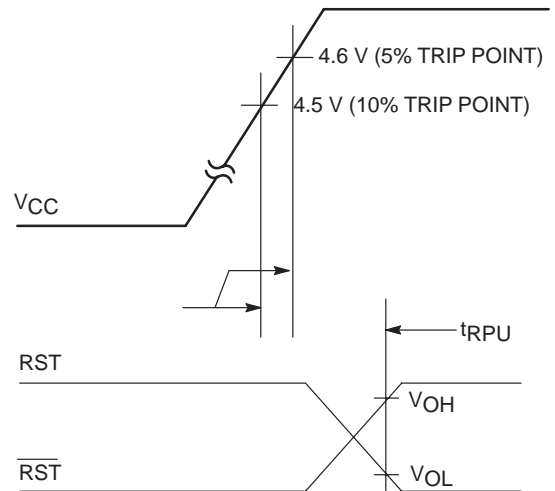
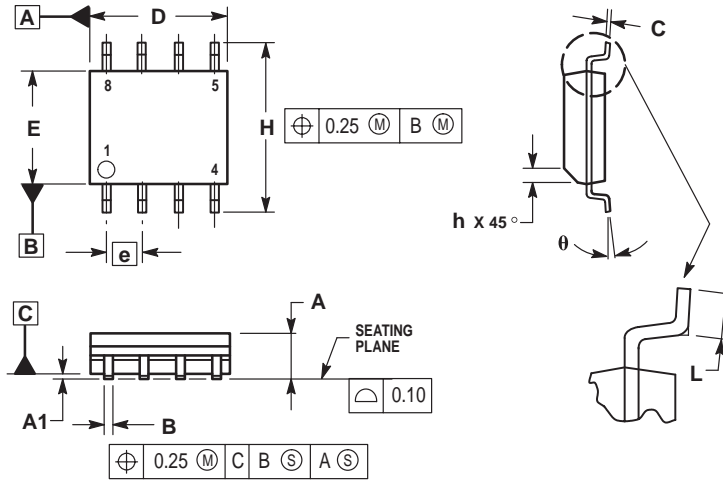

Figure 8. V_{CC} Detect Reset Output Delay (Power-Up)

NCP1232

PACKAGE DIMENSIONS

SO-8
D SUFFIX
CASE 751-06
ISSUE T



NOTES:

1. DIMENSIONING AND TOLERANCING PER ASME Y14.5M, 1994.
2. DIMENSIONS ARE IN MILLIMETER.
3. DIMENSION D AND E DO NOT INCLUDE MOLD PROTRUSION.
4. MAXIMUM MOLD PROTRUSION 0.15 PER SIDE.
5. DIMENSION B DOES NOT INCLUDE DAMBAR PROTRUSION. ALLOWABLE DAMBAR PROTRUSION SHALL BE 0.127 TOTAL IN EXCESS OF THE B DIMENSION AT MAXIMUM MATERIAL CONDITION.

DIM	MILLIMETERS	
	MIN	MAX
A	1.35	1.75
A1	0.10	0.25
B	0.35	0.49
C	0.19	0.25
D	4.80	5.00
E	3.80	4.00
e	1.27 BSC	
H	5.80	6.20
h	0.25	0.50
L	0.40	1.25
θ	0°	7°

ON Semiconductor and  are trademarks of Semiconductor Components Industries, LLC (SCILLC). SCILLC reserves the right to make changes without further notice to any products herein. SCILLC makes no warranty, representation or guarantee regarding the suitability of its products for any particular purpose, nor does SCILLC assume any liability arising out of the application or use of any product or circuit, and specifically disclaims any and all liability, including without limitation special, consequential or incidental damages. "Typical" parameters which may be provided in SCILLC data sheets and/or specifications can and do vary in different applications and actual performance may vary over time. All operating parameters, including "Typicals" must be validated for each customer application by customer's technical experts. SCILLC does not convey any license under its patent rights nor the rights of others. SCILLC products are not designed, intended, or authorized for use as components in systems intended for surgical implant into the body, or other applications intended to support or sustain life, or for any other application in which the failure of the SCILLC product could create a situation where personal injury or death may occur. Should Buyer purchase or use SCILLC products for any such unintended or unauthorized application, Buyer shall indemnify and hold SCILLC and its officers, employees, subsidiaries, affiliates, and distributors harmless against all claims, costs, damages, and expenses, and reasonable attorney fees arising out of, directly or indirectly, any claim of personal injury or death associated with such unintended or unauthorized use, even if such claim alleges that SCILLC was negligent regarding the design or manufacture of the part. SCILLC is an Equal Opportunity/Affirmative Action Employer.

PUBLICATION ORDERING INFORMATION

NORTH AMERICA Literature Fulfillment:

Literature Distribution Center for ON Semiconductor
 P.O. Box 5163, Denver, Colorado 80217 USA
Phone: 303-675-2175 or 800-344-3860 Toll Free USA/Canada
Fax: 303-675-2176 or 800-344-3867 Toll Free USA/Canada
Email: ONlit@hibbertco.com
 Fax Response Line: 303-675-2167 or 800-344-3810 Toll Free USA/Canada

N. American Technical Support: 800-282-9855 Toll Free USA/Canada

EUROPE: LDC for ON Semiconductor – European Support

German Phone: (+1) 303-308-7140 (M-F 1:00pm to 5:00pm Munich Time)
Email: ONlit-german@hibbertco.com
French Phone: (+1) 303-308-7141 (M-F 1:00pm to 5:00pm Toulouse Time)
Email: ONlit-french@hibbertco.com
English Phone: (+1) 303-308-7142 (M-F 12:00pm to 5:00pm UK Time)
Email: ONlit@hibbertco.com

EUROPEAN TOLL-FREE ACCESS*: 00-800-4422-3781

*Available from Germany, France, Italy, England, Ireland

CENTRAL/SOUTH AMERICA:

Spanish Phone: 303-308-7143 (Mon-Fri 8:00am to 5:00pm MST)
Email: ONlit-spanish@hibbertco.com

ASIA/PACIFIC: LDC for ON Semiconductor – Asia Support

Phone: 303-675-2121 (Tue-Fri 9:00am to 1:00pm, Hong Kong Time)
 Toll Free from Hong Kong & Singapore:
001-800-4422-3781
Email: ONlit-asia@hibbertco.com

JAPAN: ON Semiconductor, Japan Customer Focus Center
 4-32-1 Nishi-Gotanda, Shinagawa-ku, Tokyo, Japan 141-0031

Phone: 81-3-5740-2745
Email: r14525@onsemi.com

ON Semiconductor Website: <http://onsemi.com>

For additional information, please contact your local Sales Representative.