

FEATURES

Operating frequency 100 MHz to 4000 MHz
Digitally controlled variable gain amplifier
Supports both serial and parallel interfaces
6-bit, 0.5 dB digital step attenuator
31.5 dB gain control range with ± 0.25 dB step accuracy

Amplifier 1:

Gain: 20.0 dB @ 900 MHz
OIP3: 38.2 dBm @ 900 MHz
P1dB: 20.0 dBm @ 900 MHz
Noise figure: 2.9 dB @ 900 MHz

Amplifier 2 :

Gain: 16.9 dB @ 880 MHz
OIP3: 45.0 dBm @ 880 MHz
P1dB: 25.4 dBm @ 880 MHz
Noise figure: 4.1 dB @ 880 MHz

Single supply operation from 4.75 V to 5.25 V

Low quiescent current 195 mA

Thermally efficient 5 x 5 mm 32-Lead LFCSP

GENERAL DESCRIPTION

The ADL5243 is a high performance digitally controlled variable gain amplifier operating from 100 MHz to 4000 MHz. The VGA integrates two high performance amplifiers and a digital step attenuator (DSA). Amplifier 1 is a 20 dB gain internally matched amplifier, and amplifier 2 is a broadband $\frac{1}{4}$ W driver amplifier. The DSA is 6-bit with 31.5 dB gain control range, 0.5 dB steps, and ± 0.25 dB step accuracy. The attenuation of the DSA can be controlled using a serial or parallel interface.

The ADL5243 consumes just 195 mA and operates off a single supply ranging from 4.75 V to 5.25 V. The VGA is packaged in a thermally enhanced 5 x 5 mm 32-lead LFCSP, and is fully

FUNCTIONAL BLOCK DIAGRAM

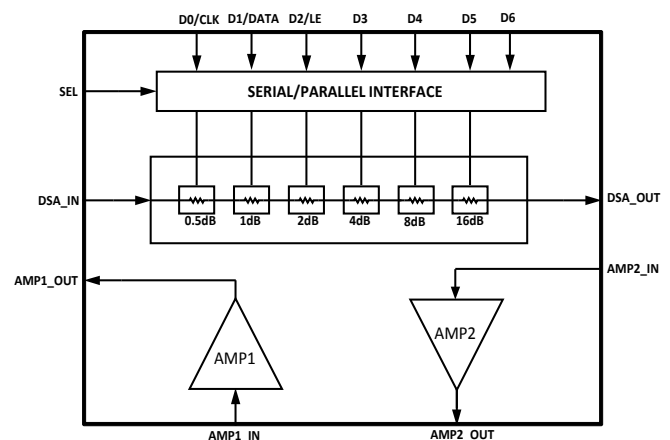

Figure 1

specified for operation from -40°C to $+85^{\circ}\text{C}$. A fully populated evaluation board is available.

Rev. PrB

Information furnished by Analog Devices is believed to be accurate and reliable. However, no responsibility is assumed by Analog Devices for its use, nor for any infringements of patents or other rights of third parties that may result from its use. Specifications subject to change without notice. No license is granted by implication or otherwise under any patent or patent rights of Analog Devices. Trademarks and registered trademarks are the property of their respective owners.

SPECIFICATIONS

VDD = 5V, VCC1 = 5V, VCC2 = 5V, T_A = 25°C

Table 1.

Parameter	Conditions	Min	Typ	Max	Unit
OVERALL FUNCTION					
Frequency Range		100		4000	MHz
Amplifier 1					
Pins AMP1_IN, AMP1_OUT					
FREQUENCY = 140MHz					
Gain			17.0		dB
vs. Frequency	±50 MHz		±1.2		dB
vs. Temperature	-40°C ≤ T _A ≤ +85°C		±0.03		dB
vs. Supply	4.75 V to 5.25 V		±0.04		dB
Output 1 dB Compression Point			17.2		dBm
Output Third-Order Intercept	Δf = 1 MHz, P _{OUT} = 0 dBm per tone		25		dBm
Noise Figure			3.4		dB
FREQUENCY = 400MHz					
Gain			19.5		dB
vs. Frequency	±50 MHz		±0.2		dB
vs. Temperature	-40°C ≤ T _A ≤ +85°C		±0.3		dB
vs. Supply	4.75 V to 5.25 V		±0.01		dB
Output 1 dB Compression Point			20.0		dBm
Output Third-Order Intercept	Δf = 1 MHz, P _{OUT} = 0 dBm per tone		36.5		dBm
Noise Figure			3.0		dB
FREQUENCY = 900MHz					
Gain			20.0		dB
vs. Frequency	±50 MHz		±0.01		dB
vs. Temperature	-40°C ≤ T _A ≤ +85°C		±0.28		dB
vs. Supply	4.75 V to 5.25 V		±0.01		dB
Output 1 dB Compression Point			20.0		dBm
Output Third-Order Intercept	Δf = 1 MHz, P _{OUT} = 0 dBm per tone		38.2		dBm
Noise Figure			2.9		dB
FREQUENCY = 2000MHz					
Gain			18.2		dB
vs. Frequency	±50 MHz		±0.04		dB
vs. Temperature	-40°C ≤ T _A ≤ +85°C		±0.35		dB
vs. Supply	4.75 V to 5.25 V		±0.04		dB
Output 1 dB Compression Point			19.0		dBm
Output Third-Order Intercept	Δf = 1 MHz, P _{OUT} = 0 dBm per tone		37.6		dBm
Noise Figure			3.1		dB
FREQUENCY = 2600MHz					
Gain			17.8		dB
vs. Frequency	±50 MHz		±0.01		dB
vs. Temperature	-40°C ≤ T _A ≤ +85°C		±0.28		dB
vs. Supply	4.75 V to 5.25 V		±0.05		dB
Output 1 dB Compression Point			18.7		dBm
Output Third-Order Intercept	Δf = 1 MHz, P _{OUT} = 0 dBm per tone		34.8		dBm
Noise Figure			3.4		dB

Parameter	Conditions	Min	Typ	Max	Unit
FREQUENCY = 3500MHz					
Gain			16.7		dB
vs. Frequency	± 50 MHz		± 0.03		dB
vs. Temperature	$-40^{\circ}\text{C} \leq T_A \leq +85^{\circ}\text{C}$		± 0.37		dB
vs. Supply	4.75 V to 5.25 V		± 0.07		dB
Output 1 dB Compression Point			18.2		dBm
Output Third-Order Intercept	$\Delta f = 1$ MHz, $P_{\text{OUT}} = 0$ dBm per tone		32.5		dBm
Noise Figure			3.8		dB
FREQUENCY = 4000MHz					
Gain			15.5		dB
vs. Frequency	± 50 MHz		± 0.19		dB
vs. Temperature	$-40^{\circ}\text{C} \leq T_A \leq +85^{\circ}\text{C}$		± 0.73		dB
vs. Supply	4.75 V to 5.25 V		± 0.08		dB
Output 1 dB Compression Point			17.5		dBm
Output Third-Order Intercept	$\Delta f = 1$ MHz, $P_{\text{OUT}} = 0$ dBm per tone		28		dBm
Noise Figure			3.7		dB

Parameter	Conditions	Min	Typ	Max	Unit
Amplifier 2	Pins AMP2_IN, AMP2_OUT				
FREQUENCY = 880MHz					
Gain			16.9		dB
vs. Frequency	±50 MHz		±0.3		dB
vs. Temperature	-40°C ≤ T _A ≤ +85°C		±0.6		dB
vs. Supply	4.75 V to 5.25 V		±0.1		dB
Output 1 dB Compression Point			25.4		dBm
Output Third-Order Intercept	Δf = 1 MHz, P _{OUT} = 10 dBm per tone		45		dBm
Noise Figure			4.1		dB
FREQUENCY = 2100MHz					
Gain			13.2		dB
vs. Frequency	±50 MHz		±0.33		dB
vs. Temperature	-40°C ≤ T _A ≤ +85°C		±0.8		dB
vs. Supply	4.75 V to 5.25 V		±0.06		dB
Output 1 dB Compression Point			25.7		dBm
Output Third-Order Intercept	Δf = 1 MHz, P _{OUT} = 10 dBm per tone		42		dBm
Noise Figure			4.4		dB
FREQUENCY = 2600MHz					
Gain			12.6		dB
vs. Frequency	±50 MHz		±0.4		dB
vs. Temperature	-40°C ≤ T _A ≤ +85°C		±0.7		dB
vs. Supply	4.75 V to 5.25 V		±0.07		dB
Output 1 dB Compression Point			25.7		dBm
Output Third-Order Intercept	Δf = 1 MHz, P _{OUT} = 10 dBm per tone		41		dBm
Noise Figure			4.0		dB
FREQUENCY = 3500MHz					
Gain			12.0		dB
vs. Frequency	±50 MHz		±0.05		dB
vs. Temperature	-40°C ≤ T _A ≤ +85°C		±0.8		dB
vs. Supply	4.75 V to 5.25 V		±0.07		dB
Output 1 dB Compression Point			25.7		dBm
Output Third-Order Intercept	Δf = 1 MHz, P _{OUT} = 10 dBm per tone		38		dBm
Noise Figure			4.9		dB

Parameter	Conditions	Min	Typ	Max	Unit
Digital Step Attenuator	Pins DSA_IN, DSA_OUT				
FREQUENCY = 400 - 1000MHz					
Insertion Loss	Minimum Attenuation		1.7		dB
Attenuation Range			31.5		dB
Step Size			0.5		dB
Input Return Loss			15		dB
Output Return Loss			13		dB
Input 1 dB Compression Point			28		dBm
Input Third-Order Intercept	$\Delta f = 1 \text{ MHz}$, $P_{\text{OUT}} = 8 \text{ dBm/tone}$, Minimum Attenuation		51		dBm
FREQUENCY = 1400 - 2200MHz					
Insertion Loss	Minimum Attenuation		2.4		dB
Attenuation Range			31.5		dB
Step Size			0.5		dB
Input Return Loss			12		dB
Output Return Loss			12		dB
Input 1 dB Compression Point			28		dBm
Input Third-Order Intercept	$\Delta f = 1 \text{ MHz}$, $P_{\text{OUT}} = 16 \text{ dBm/tone}$, Minimum Attenuation		50		dBm
FREQUENCY = 2200 - 2700MHz					
Insertion Loss	Minimum Attenuation		3.4		dB
Attenuation Range			31.5		dB
Step Size			0.5		dB
Input Return Loss			10		dB
Output Return Loss			10		dB
Input 1 dB Compression Point			28		dBm
Input Third-Order Intercept	$\Delta f = 1 \text{ MHz}$, $P_{\text{OUT}} = 15 \text{ dBm/tone}$, Minimum Attenuation		49		dBm
POWER SUPPLIES	Pin VDD				
Voltage		4.75	5.0	5.25	V
Supply Current			195		mA

ABSOLUTE MAXIMUM RATINGS

Table 2.

Parameter	Rating
Supply Voltage, VDD	TBD V
Lead Temperature (Soldering, 60 sec)	TBD °C
Internal Power Dissipation	TBD W
θ_{JA} (Exposed Paddle Soldered Down)	TBD °C/W
Maximum Junction Temperature	150°C
Operating Temperature Range	-40°C to +85°C
Storage Temperature Range	-65°C to +150°C

Stresses above those listed under Absolute Maximum Ratings may cause permanent damage to the device. This is a stress rating only; functional operation of the device at these or any other conditions above those indicated in the operational section of this specification is not implied. Exposure to absolute maximum rating conditions for extended periods may affect device reliability.

ESD CAUTION



ESD (electrostatic discharge) sensitive device. Charged devices and circuit boards can discharge without detection. Although this product features patented or proprietary protection circuitry, damage may occur on devices subjected to high energy ESD. Therefore, proper ESD precautions should be taken to avoid performance degradation or loss of functionality.

PIN CONFIGURATION AND FUNCTION DESCRIPTIONS

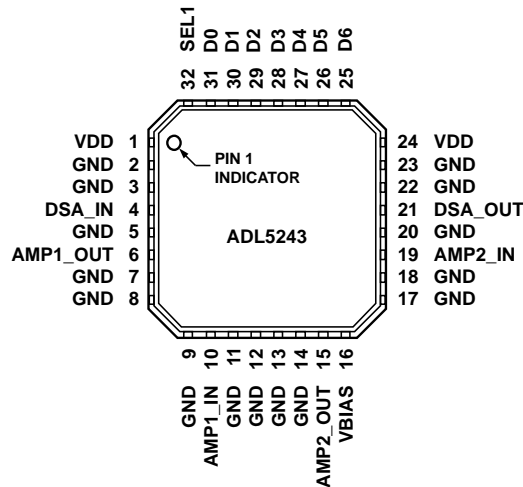

Figure 2. Pin Configuration

Table 3. Pin Function Descriptions

Pin No.	Mnemonic	Description
1, 24	VDD	Supply voltage for DSA, Connect to 5V supply
2, 3, 5, 7, 8, 9, 11, 12, 13, 14, 17, 18, 20, 22, 23	GND	Ground connection, connect to low impedance ground plane
4	DSA_IN	RF Input to DSA
6	AMP1_OUT	RF Output from Amplifier 1
10	AMP1_IN	RF Input to Amplifier 1
15	AMP2_OUT	RF Output from Amplifier 2
16	VBIAS	Bias for Amplifier 2
19	AMP2_IN	RF Input to Amplifier 2
21	DSA_OUT	RF Output from DSA
25	D6	Data bit in Parallel Mode (LSB), Connect to supply in Serial Mode
26	D5	Data bit in Parallel Mode, Connect to ground in Serial Mode
27	D4	Data bit in Parallel Mode, Connect to ground in Serial Mode
28	D3	Data bit in Parallel Mode, Connect to ground in Serial Mode
29	D2	Data bit in Parallel Mode and Latch Enable in Serial Mode
30	D1	Data bit in Parallel Mode (MSB) and Data in Serial Mode
31	D0	Connect to ground in Parallel Mode and Clock in Serial Mode
32	SEL1	Connect to supply for Parallel mode operation, connect to ground for serial mode operation

TYPICAL PERFORMANCE CHARACTERISTICS

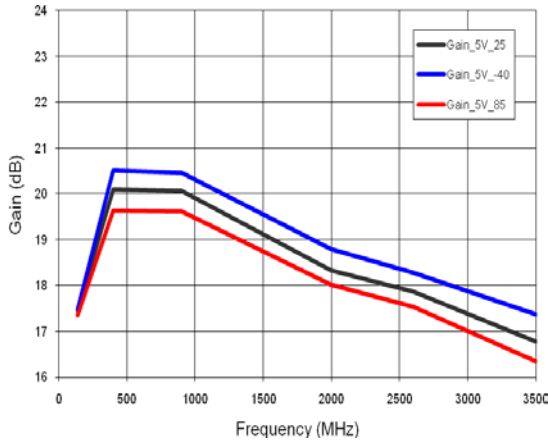

Figure 3 Amp1: Gain vs. Freq and Temp

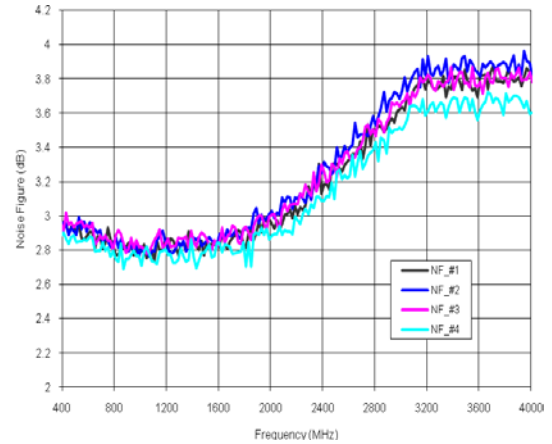

Figure 6 Amp1: Noise Figure vs. Freq

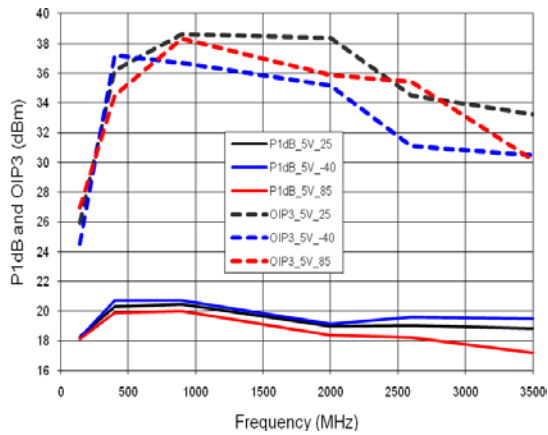

Figure 4 Amp1: P1dB and OIP3 vs. Freq and Temp

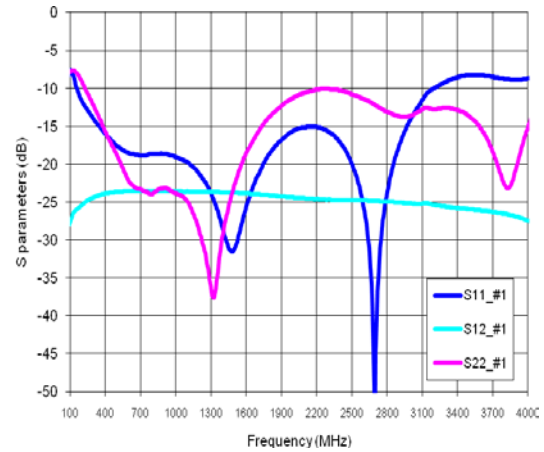

Figure 7 Amp1: S parameters vs. Freq

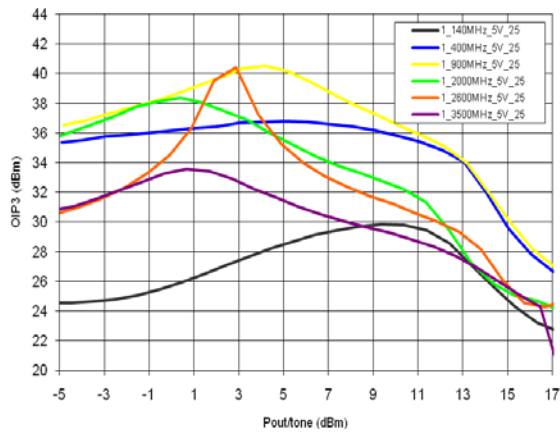

Figure 5 Amp1: OIP3 vs Pout and Freq

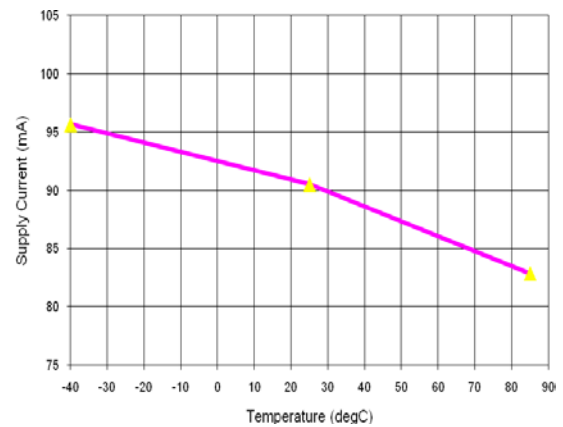

Figure 8 Amp1: Supply Current vs. Temp

TYPICAL PERFORMANCE CHARACTERISTICS

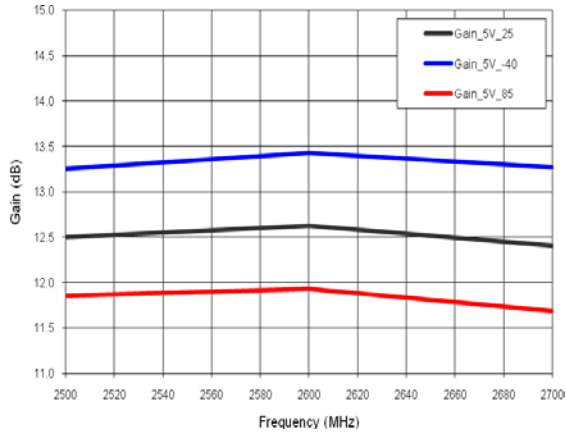

Figure 9 Amp2: Gain vs. Freq and Temp

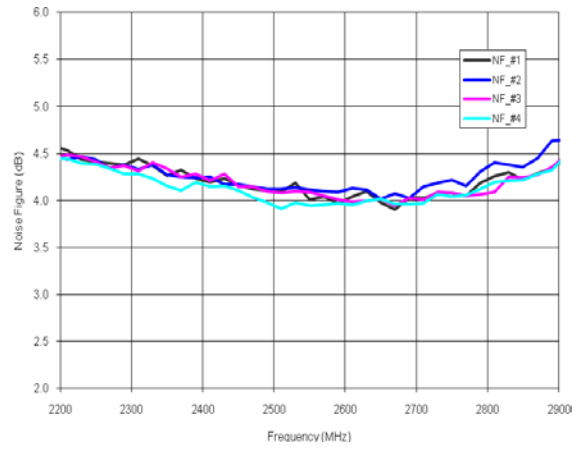

Figure 12 Amp2: Noise Figure vs. Freq

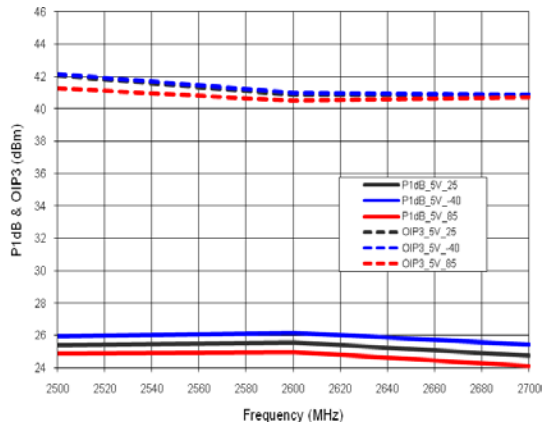

Figure 10 Amp2: P1dB and OIP3 vs. Freq and Temp

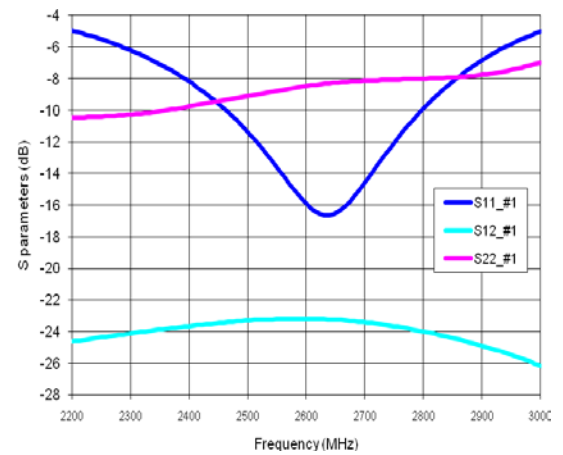

Figure 13 Amp2: S parameters vs. Freq

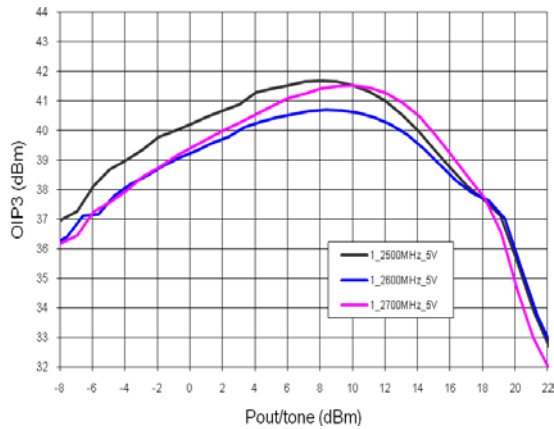

Figure 11 Amp2: OIP3 vs Pout and Freq

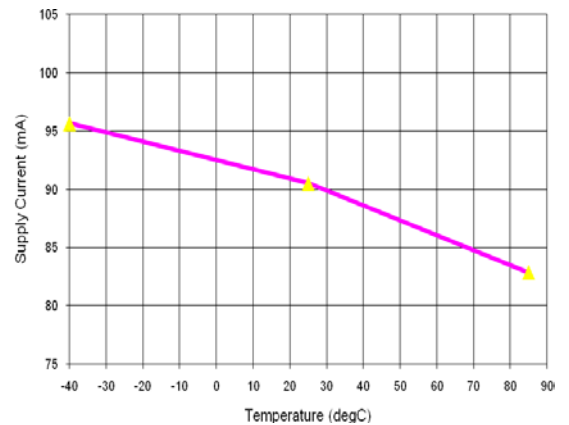

Figure 14 Amp2: Supply Current vs Temp

TYPICAL PERFORMANCE CHARACTERISTICS

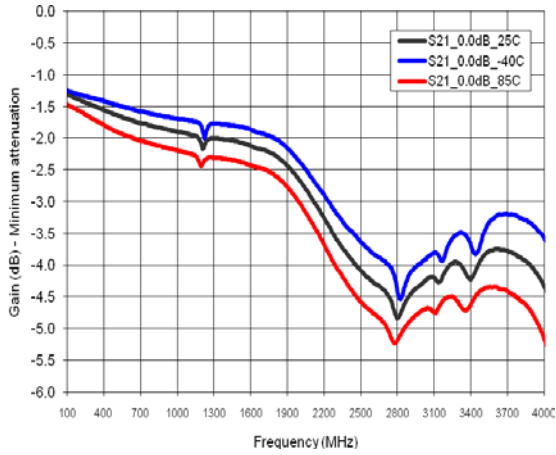

Figure 15 DSA: Gain vs Freq and Temp (minimum attenuation)

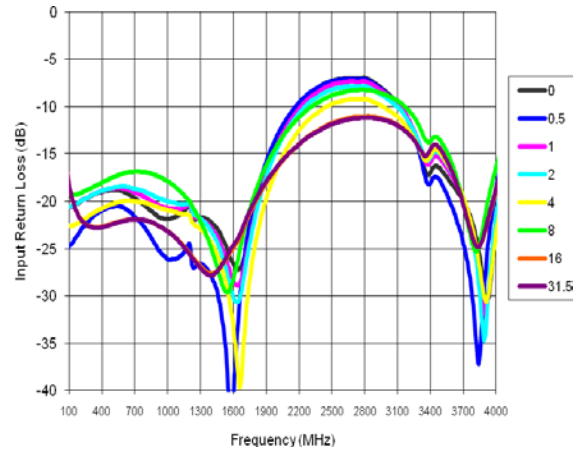

Figure 17 DSA: S11 vs Freq

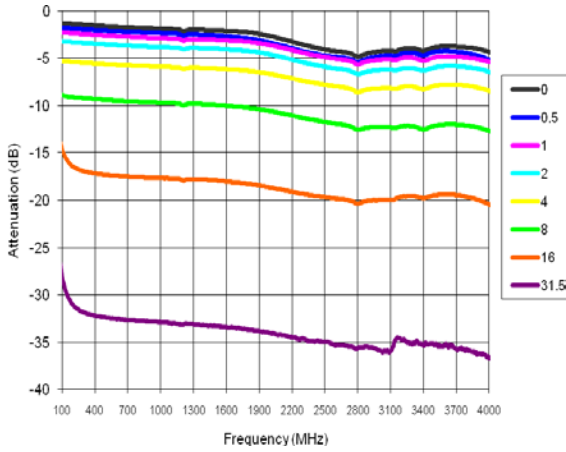

Figure 16 DSA: Attenuation vs. Freq

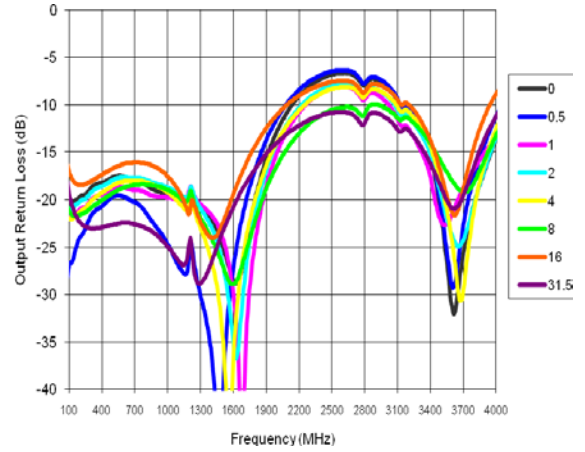

Figure 18 DSA: S22 vs Freq

SPI TIMING SEQUENCE

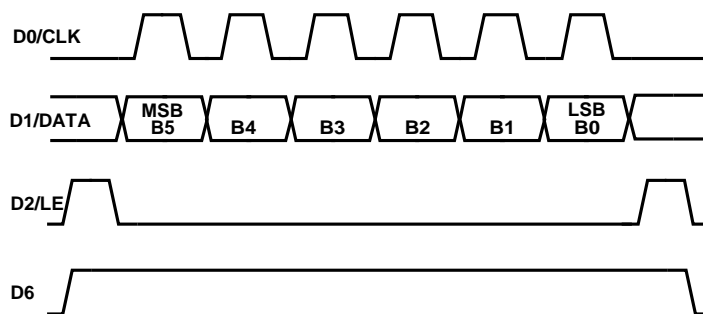

Figure 19. SPI Timing Sequence

Figure 19 is the timing sequence for the SPI function using a 6-bit operation. The clock can be as fast as 20MHz. In serial mode operation register B5 (MSB) comes in first and register B0 (LSB) comes in last.

Table 4. Mode Selection Table

Pin SEL 1	Functionality
Ground	Serial Mode
Supply	Parallel Mode

Table 5. DSA Attenuation Truth Table – Serial Mode

Attenuation State	B5 (MSB)	B4	B3	B2	B1	B0 (LSB)
0 dB (reference)	1	1	1	1	1	1
0.5 dB	1	1	1	1	1	0
1.0 dB	1	1	1	1	0	1
2.0 dB	1	1	1	0	1	1
4.0 dB	1	1	0	1	1	1
8.0 dB	1	0	1	1	1	1
16.0 dB	0	1	1	1	1	1
31.5 dB	0	0	0	0	0	0

Table 6. DSA Attenuation Truth Table – Parallel Mode

Attenuation State	D1 (MSB)	D2	D3	D4	D5	D6 (LSB)
0 dB (reference)	1	1	1	1	1	1
0.5 dB	1	1	1	1	1	0
1.0 dB	1	1	1	1	0	1
2.0 dB	1	1	1	0	1	1
4.0 dB	1	1	0	1	1	1
8.0 dB	1	0	1	1	1	1
16.0 dB	0	1	1	1	1	1
31.5 dB	0	0	0	0	0	0

OUTLINE DIMENSIONS

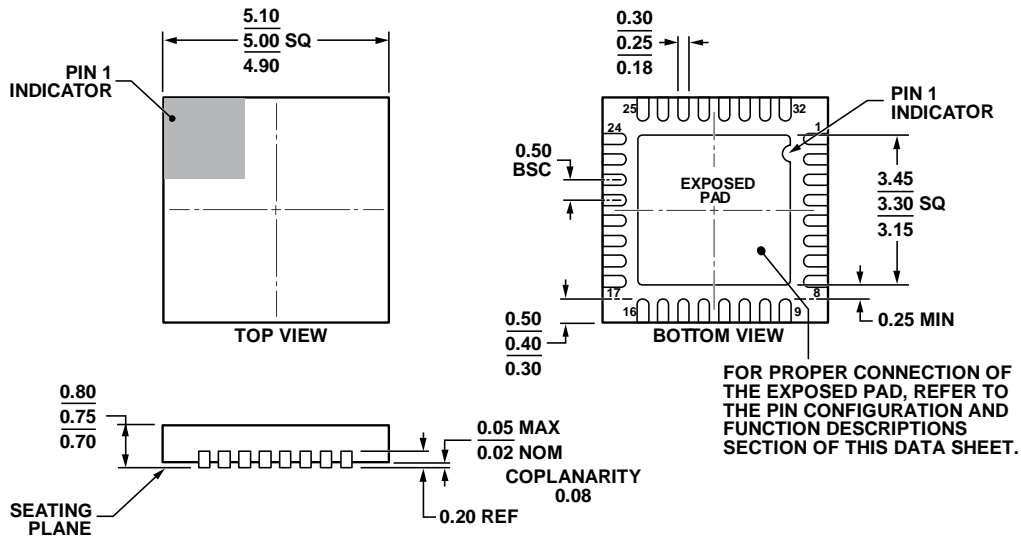

COMPLIANT TO JEDEC STANDARDS MO-220-WHHD.

Figure 20. 2-Lead Lead Frame Chip Scale Package [LFCSP_WQ]
5 mm x 5 mm Body, Very Very Thin Quad
(CP-32-13)
Dimensions shown in millimeters

033005-A

ORDERING GUIDE

Model	Temperature Range	Package Description	Package Option
ADL5243ACPZ-R7 ADL5243-EVALZ	-40°C to +85°C	32 Lead Lead Frame Chip Scale Package LFCSP_WQ	CP-32-13