

FEATURES

- RF Frequency 1200MHz to 2500MHz**
- IF Range 40 to 450MHz**
- Power Conversion Gain of 8.1dB**
- SSB Noise Figure of 9.4dB**
- SSB Noise Figure with 10dBm Blocker of 18dB**
- Input IP3 of 29dBm**
- Input P_{1dB} of 11 dBm**
- Typical LO Drive of 0 dBm**
- Single-ended, 50Ω RF and LO Input Ports**
- High Isolation SPDT LO Input Switch**
- Single Supply Operation: 3.3 to 5 V**
- Exposed Paddle 5 x 5 mm, 20 Lead LFCSP Package**
- 2000V HBM / 500V FICDM ESD Performance**

APPLICATIONS

- Cellular Base Station Receivers**
- Transmit Observation Receivers**
- Radio Link Downconverters**

GENERAL DESCRIPTION

The ADL5355 utilizes a highly linear doubly balanced passive mixer core along with integrated RF and LO balancing circuitry to allow for single-ended operation. The ADL5355 incorporates an RF balun allowing for optimal performance over a 1200 to 2500 MHz RF input frequency range using low-side LO injection for RF frequencies between 1700-2500MHz, and high-side injection for frequencies between 1200-MHz and 1700MHz. (For a high side injection version for the 1700-2500MHz band, please contact the factory). The balanced passive mixer arrangement provides good LO to RF leakage, typically better than -25dBm, and excellent intermodulation performance. The balanced mixer core also provides extremely high input linearity allowing the device to be used in demanding cellular applications where in-band blocking signals may otherwise result in the degradation of dynamic performance. A high linearity IF buffer amp follows the passive mixer core, to yield a typical power conversion gain of 8.1dB, and can be utilized with a wide range of output impedances. (For a higher IIP3 version of the single mixer without the IF amplifiers, please contact the factory).

REV. PrD

Information furnished by Analog Devices is believed to be accurate and reliable. However, no responsibility is assumed by Analog Devices for its use, nor for any infringements of patents or other rights of third parties that may result from its use. Specifications subject to change without notice. No license is granted by implication or otherwise under any patent or patent rights of Analog Devices. Trademarks and registered trademarks are the property of their respective companies.

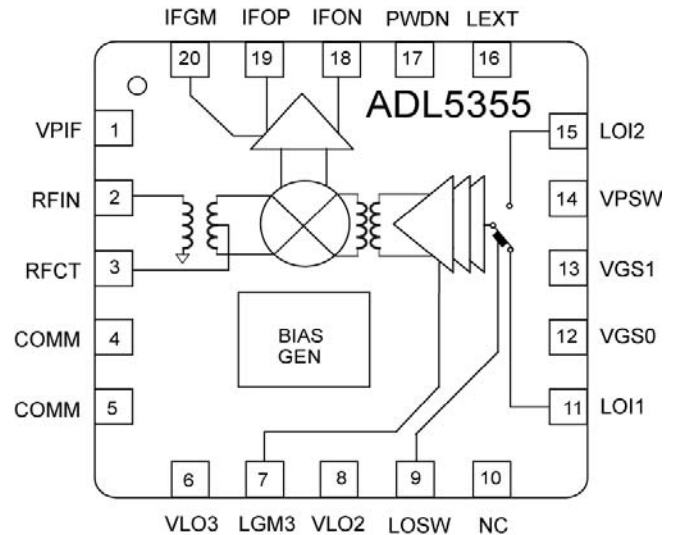

Figure 1. Functional Block Diagram

The ADL5355 provides two switched LO paths that can be utilized in TDD applications where it is desirable to ping-pong between two local oscillators. LO current can be externally set using a resistor to minimize DC current commensurate with the desired level of performance. An additional logic pin is provided to power down (<100uA) the circuit when desired.

For low voltage applications, the ADL5355 is capable of operation at voltages down to 3.3V with substantially reduced current.

The ADL5355 is fabricated using a BiCMOS high performance IC process. The device will be available in a 5mm x 5mm 20-lead LFCSP package and operates over a -40°C to +85°C temperature range. An evaluation board is also available.

RF Frequency	Single Mixer	Single Mixer + IF Amp	Dual Mixer + IF Amp
500MHz to 1700MHz	ADL5367	ADL5357	ADL5358
1200MHz to 2500MHz	ADL5365	ADL5355	ADL5356

ADL5355—Specifications

Table 1. $V_S = 5\text{ V}$, $T_A = 25^\circ\text{C}$, $f_{RF} = 1900\text{ MHz}$, $f_{LO} = 1697\text{ MHz}$, LO power = 0 dBm, $Z_o = 50\Omega$, unless otherwise noted

Parameter	Conditions	Min	Typ	Max	Unit	
RF INPUT INTERFACE						
Return Loss	Tunable to >20dB over a limited bandwidth		10		dB	
Input Impedance			50		Ω	
RF Frequency Range		1200		2500	MHz	
OUTPUT INTERFACE						
Output Impedance	Differential impedance, $f = 200\text{ MHz}$		200		Ω	
IF Frequency Range	Externally generated	40		450	MHz	
DC Bias Voltage ¹			V_S		V	
LO INTERFACE						
LO Power	Low or High Side LO injection	-3	0	+10	dBm	
Return Loss			14		dB	
Input Impedance			50		Ω	
LO Frequency Range		1300		2200	MHz	
DYNAMIC PERFORMANCE						
Power Conversion Gain	Including 4:1 IF port transformer and PCB loss		8.1		dB	
Voltage Conversion Gain	$Z_{SOURCE} = 50\Omega$, Differential $Z_{LOAD} = 200\Omega$ Differential		14.4		dB	
SSB Noise Figure	10dBm Blocker present +/-5MHz from wanted RF input, LO source filtered		9.4		dB	
SSB Noise Figure Under-Blocking			18		dB	
Input Third Order Intercept		$f_{RF1} = 1900\text{ MHz}$, $f_{RF2} = 1901\text{ MHz}$, $f_{LO} = 1697\text{ MHz}$, each RF tone at -10 dBm		29		dBm
Input Second Order Intercept		$f_{RF1} = 1900\text{ MHz}$, $f_{RF2} = 1950\text{ MHz}$, $f_{LO} = 1697\text{ MHz}$, each RF tone at -10 dBm		52.5		dBm
Input 1 dB Compression Point				11		dBm
LO to IF Output Leakage	Unfiltered IF Output		-17		dBm	
LO to RF Input Leakage			-38		dBm	
RF to IF Output Isolation			39		dB	
IF/2 Spurious	-10 dBm Input Power		-69		dBc	
IF/3 Spurious	-10dBm Input Power		-72		dBc	
POWER INTERFACE						
Supply Voltage	Resistor Programmable	3.3	5	5.5	V	
Quiescent Current			190		mA	

¹ Supply voltage must be applied from external circuit through choke inductors

ADL5355—Specifications at $V_S=3.3V$ **Table 2.** $V_S = 3.3 V$, $T_A = 25^\circ C$, $f_{RF} = 1900 MHz$, $f_{LO} = 1697 MHz$, LO power = 0 dBm, $Z_o = 50\Omega$, unless otherwise noted

Parameter	Conditions	Min	Typ	Max	Unit
DYNAMIC PERFORMANCE					
Power Conversion Gain	Including 4:1 IF port transformer and PCB loss		8.7		dB
Voltage Conversion Gain	$Z_{SOURCE} = 50\Omega$, Differential $Z_{LOAD} = 200\Omega$ Differential		15.2		dB
SSB Noise Figure	Including 4:1 IF port transformer and PCB loss		8.9		dB
Input Third Order Intercept	$f_{RF1} = 1899.5 MHz$, $f_{RF2} = 1900.5 MHz$, $f_{LO} = 1697 MHz$, each RF tone at -10 dBm		20		dBm
Input Second Order Intercept	$f_{RF1} = 1900 MHz$, $f_{RF2} = 1850 MHz$, $f_{LO} = 1697 MHz$, each RF tone at -10 dBm		50		dBm
Input 1 dB Compression Point			7		dBm
POWER INTERFACE					
Supply Voltage		3.0	3.3	3.6	V
Quiescent Current	Resistor Programmable		120		mA

ABSOLUTE MAXIMUM RATINGS

Table 2.

Parameter	Rating
Supply Voltage, V_{POS}	5.5 V
PWDN, LOSW, VGS0, VGS1	TBD
RF Input Power RFIN	TBD
Internal Power Dissipation	TBD
θ_{JA} (Exposed Paddle Soldered Down)	TBD
θ_{JC} (At Exposed Paddle)	TBD
Maximum Junction Temperature	TBD
Operating Temperature Range	-40°C to +85°C
Storage Temperature Range	-65°C to +150°C

Stresses above those listed under Absolute Maximum Ratings may cause permanent damage to the device. This is a stress rating only; functional operation of the device at these or any other conditions above those indicated in the operational section of this specification is not implied. Exposure to absolute maximum rating conditions for extended periods may affect device reliability.

ESD CAUTION



ESD (electrostatic discharge) sensitive device. Charged devices and circuit boards can discharge without detection. Although this product features patented or proprietary protection circuitry, damage may occur on devices subjected to high energy ESD. Therefore, proper ESD precautions should be taken to avoid performance degradation or loss of functionality.

PIN CONFIGURATION AND FUNCTION DESCRIPTIONS

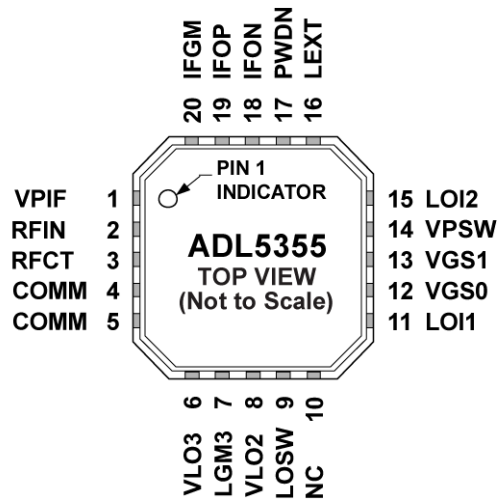

Figure 2. Pin Configuration

Table 3. Pin Function Descriptions

Pin No.	Mnemonic	Function
1	VPIF	Positive Supply Voltage for IF Amplifier: 5.00 V.
2	RFIN	RF Input. Must be ac-coupled.
3	RFCT	RF Balun Center Tap (AC Ground).
4, 5	COMM	Device Common (DC Ground).
6, 8	VLO3, VLO2	Positive Supply Voltage for LO Amplifier.
7	LGM3	LO Amplifier Bias Control.
9	LOSW	LO Switch.
10	NC	No Connect.
11, 15	LOI1, LOI2	LO Input. Must be ac-coupled.
12, 13	VGS0, VGS1	Mixer Gate Bias Control. Ground for nominal operation.
14	VPSW	Positive Supply Voltage for LO Switch.
16	LEXT	IF Return (Ground).
17	PWDN	Connect to Ground for Normal Operation. Connect pin to 3.3V for disable mode.
18, 19	IFON, IFOP	Differential IF output (Open Collectors). Each requires DC bias of 5.00 V (Nominal).
20	IFGM	IF Amplifier Bias Control.

TYPICAL PERFORMANCE CHARACTERISTICS

$V_S = 5\text{ V}$, $T_A = 25^\circ\text{C}$, as measured using typical circuit schematic with low-side LO unless otherwise noted.

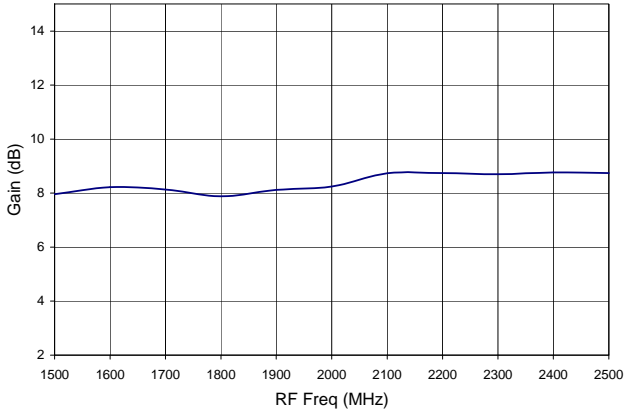

Figure 3. Conversion Gain versus RF Frequency

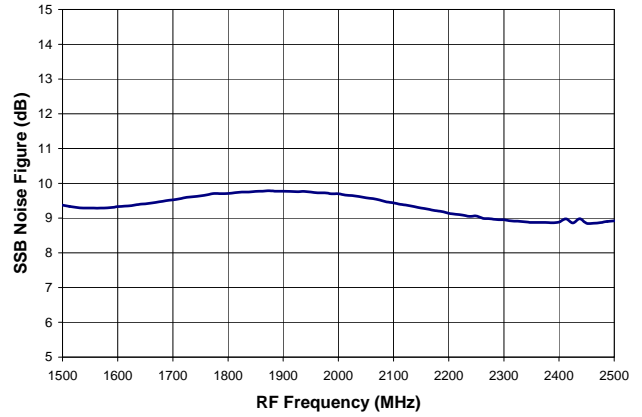

Figure 6. Single-Sideband NF versus RF Frequency

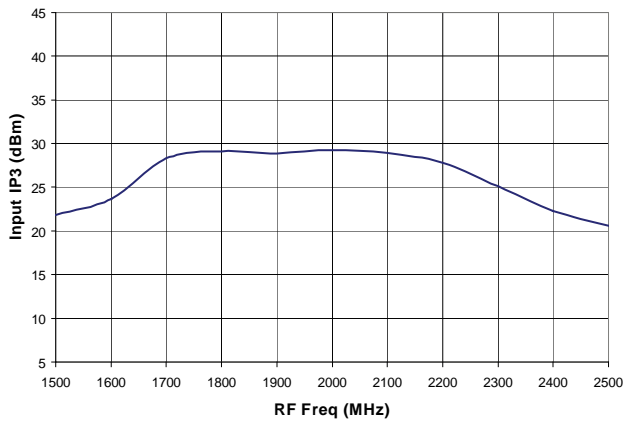

Figure 4. IIP3 versus RF Frequency

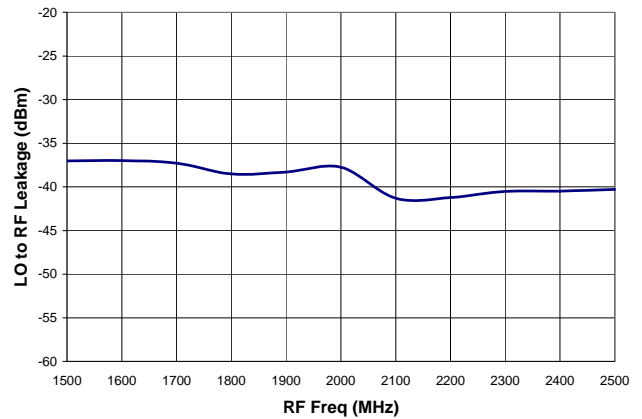

Figure 7. LO to RF Leakage versus LO Frequency

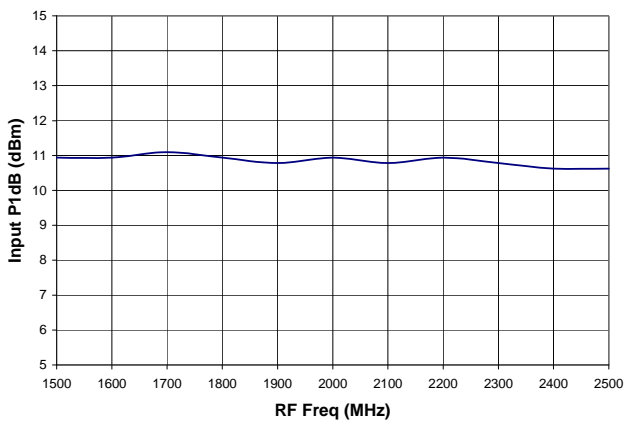

Figure 5. IP1dB versus RF Frequency

EVALUATION BOARD

An evaluation board is available for the family of double balanced mixers, including ADL5355 and ADL5357. The standard evaluation board schematic is presented in Figure 8. The evaluation board is fabricated on a multilayer Rogers board. Table 4 details the various configuration options of the evaluation board.

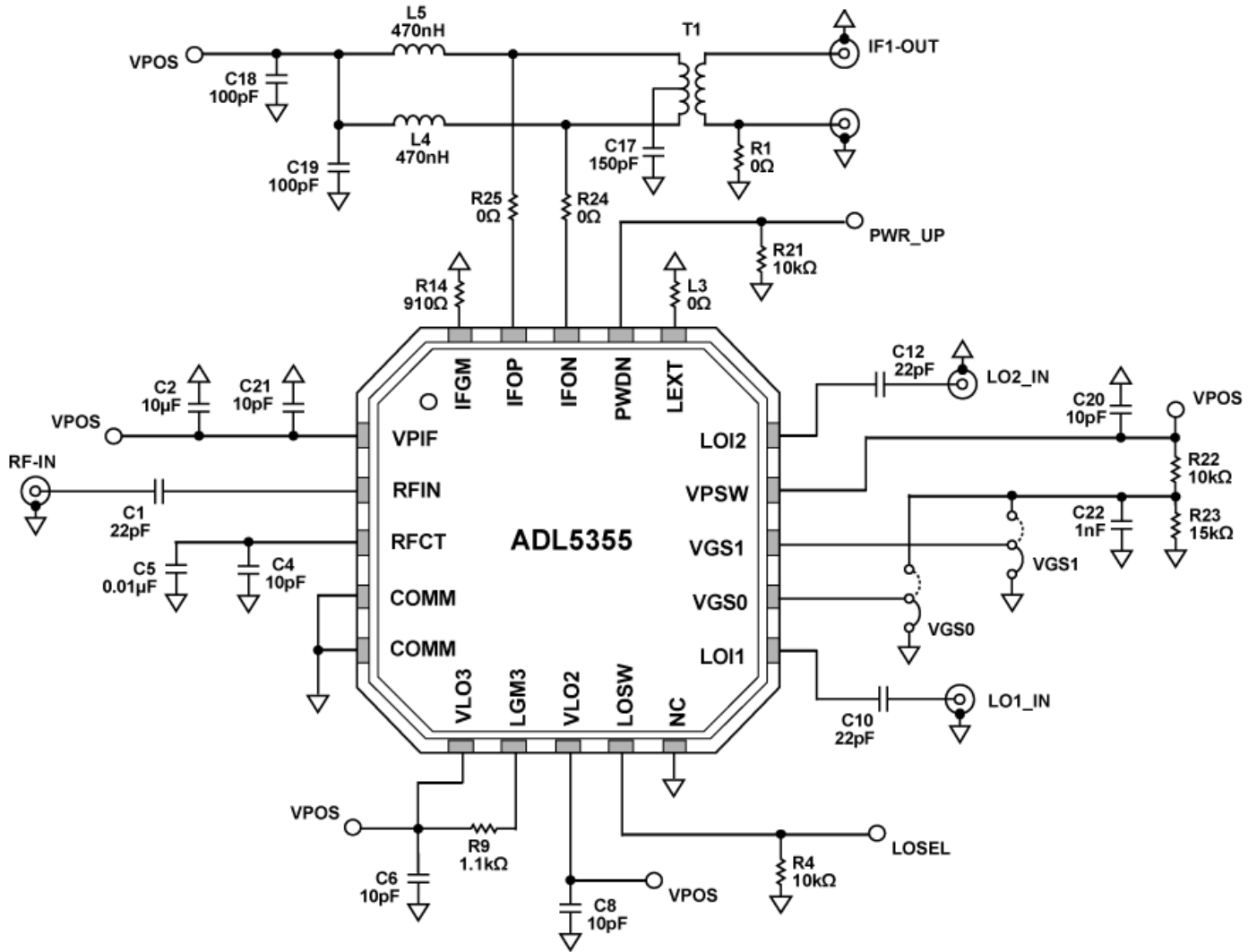

Figure 8. Evaluation Board Schematic.

Table 4. Eval Board Configuration

Components	Function	Default Conditions
C2, C6, C8, C18, C19, C20, C21	Power Supply Decoupling. Nominal supply decoupling consists a 10 μF capacitor to ground in parallel with 10pF capacitors to ground positioned as close to the device as possible.	C2 = 10 μF (size 0603) C6, C8, C20, C21 = 10 pF (size 0402) C18, C19 = 100 pF (size 0402)
C1, C4, C5	RF Input Interface. The input channels is ac-coupled through C1. C4 and C5 provide bypassing for the center taps of the RF input baluns.	C1 = 22 pF (size 0402) C4 = 10 pF (size 0402) C5 = 0.01 μF (size 0402)

T1, C17, L4, L5, R1, R24, R25	IF Output Interface. The open collector IF output interfaces are biased through pull-up choke inductors L4 and L5. T1 is a 4:1 impedance transformer used to provide a single ended IF output interface, with C17 providing center-tap bypassing. R1 should be removed for balanced output operation.	C17 = 150 pF (size 0402) T1 = TC4-1W+ (MiniCircuits) L4, L5 = 470 nH (size 1008) R1, R24, R25 = 0 Ω (size 0402)
C10, C12, R4	LO Interface. C10 and C12 provide ac-coupling for the LO1_IN and LO2_IN local oscillator inputs. LOSEL selects the appropriate LO input for both mixer cores. R4 provides a pull-down to ensure LO1_IN is enabled when the LOSEL test point has logic low. LO2_IN is enabled when LOSEL is pulled to logic high.	C10, C12 = 22pF (size 0402) R4 = 10k Ω (size 0402)
R21	PWDN Interface. R21 pulls the PWDN logic low and enables the device. PWR_UP test point allows PWDN interface to be exercised using external logic generator. It is permissible to ground the PWDN pin for nominal operation.	R21 = 10k Ω (size 0402)
C22, L3, R9, R14, R22, R23, VGS0, VGS1	Bias Control. R22 and R23 form a voltage divider to provide a 3V for logic control, bypassed to ground through C22. VGS0 and VGS1 jumpers provide programmability at pin VGS0 and VGS1. It is recommended to pull these two pins to ground for nominal operation. R9 sets the bias point for the internal LO buffers. R14 sets the bias point for the internal IF amplifiers.	C22 = 1 nF (size 0402) L3 = 0 Ω (size 0603) R9 = 1.1 k Ω (size 0402) R14 = 910 Ω (size 0402) R22 = 10k Ω (size 0402) R23 = 15k Ω (size 0402) VGS0 = VGS1 = 3-pin shunt

OUTLINE DIMENSIONS



20-Lead Lead Frame Chip Scale Package [LFCSP_VQ]
 5 x 5 mm Body, Very Thin Quad
 (CP-20-5)
 Dimensions shown in millimeters

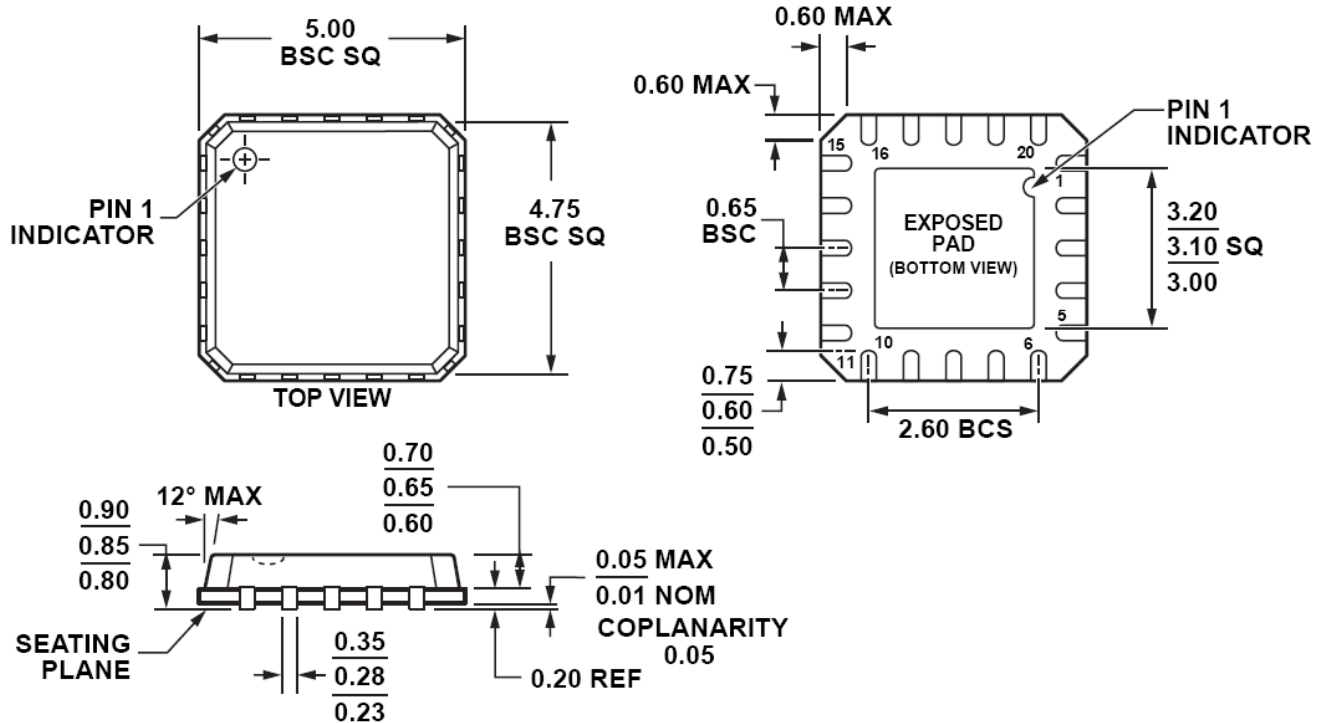

COMPLIANT TO JEDEC STANDARDS MO-220-VHHC

Figure 9. 20-Lead Lead Frame Chip Scale Package [LFCSP_VQ]
 5 mm x 5 mm Body, Very Thin Quad (CP-20-5)
 Dimensions shown in millimeters

110807-B

ORDERING GUIDE

Models	Temperature Range	Package Description	Package Option	Branding	Transport Media Quantity
ADL5355XCPZ-R7 ¹	-40°C to +85°C	20-Lead Lead Frame Chip Scale Package [LFCSP_VQ]	CP-20-5	TBD	TBD, Reel
ADL5355-EVALZ		Evaluation Board			1

¹ Z = Pb-free part.