

EPC1196G-X



- Unregulated DC/DC Converter
- Very High Efficiency : 80%-88% Typ.
- Operating Temperature : 0°C to +70°C
- Pri. & Sec. Wdg's : Double Insulated Wire
- Input/Output Isolation : 3000 Vrms
- UL94V-0 Recognized Materials

Electrical Specifications

PCA Part Numbers	V In Volts (± 10%)	V Out Volts	I Out (mA Max.)	Ripple & Noise (mV p-p)		Input Ripple Current (mA p-p)		Efficiency (% Typ.) @ Full Load	Input/Output Isolation (Vrms)
				Typ.	Max.	Typ.	Max.		
EPC1196G-1	5.0	5.0	100	16.5	25.0	8.0	15.0	80	3000
EPC1196G-2	5.0	6.5	77	16.5	25.0	9.0	15.0	84	3000
EPC1196G-3	5.0	9.0	56	14.5	25.0	8.0	15.0	87	3000
EPC1196G-4	5.0	12.0	42	13.5	25.0	8.0	15.0	88	3000
EPC1196G-5	5.0	15.0	33.33	12.0	25.0	9.0	15.0	88	3000

Notes :

1. Voltage Accuracy : ±1% Typ. @ Maximum Load
2. Input Filter : Capacitor
3. Line Voltage Regulation : 1%/ (Output Voltage Change Percentage/Input Voltage Change Percentage)
4. Load Voltage Regulation (10% to 100% Full Load) : +15% Max., -5% Max. for 5.0 V, 6.5 V, 9.0 V Out
+10% Max., -5% Max. for 12 V, 0.15 V Out
5. Short Circuit Duration : 1 Second
6. Output Ripple Filtering : Simple 33 KHz L/C Filter can be added to reduce Output Ripple & Noise to 2 mV p-p
7. Minimum Load Requirement : 10%
8. Absolute Maximum Rating : V In = 7.0 Volt Max.
9. Input Current @ 0 Load : 4.5 mA Typ.
10. Load Voltage Regulation @ 0% Load : +35% Max. for 5.0 V, 6.5 V Out
+ 25% Max. for 9.0 V Out
+ 20% Max. for 12 V, 15 V Out

Package

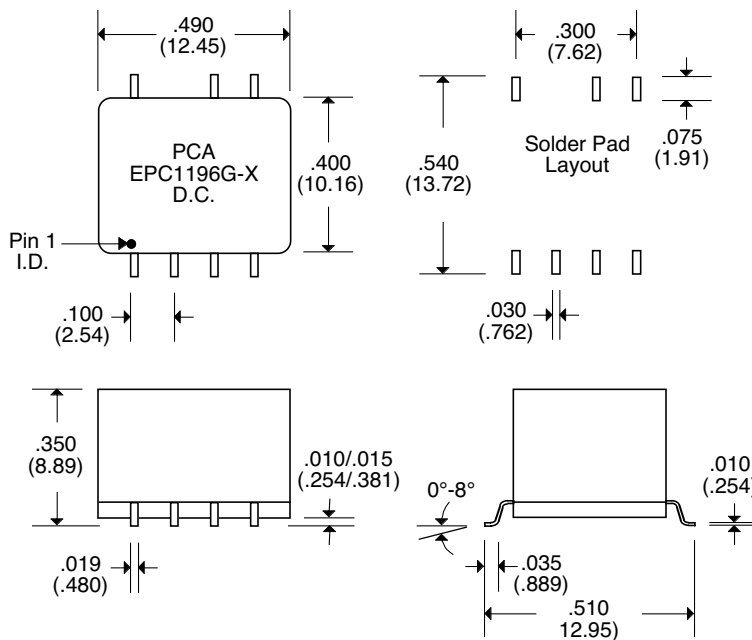

Pin Connections

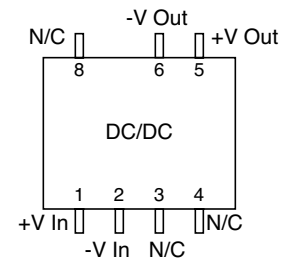

Unless Otherwise Specified Dimensions are in Inches /mm ± .010 / .25