

Features

- 1.6A, 0.21 Ω , 14V Power MOSFET
- Operating input voltage: +2.6V to +5.5V
- Adjustable Output from V_{IN} to 12V
- 640kHz / 1.2MHz pin selectable switching Frequency
- 0.1 μ A shutdown Current
- Built-in Soft-Start function
- Small 8-Pin MSOP Package

Applications

- LCD Displays
- Digital Cameras
- Portable Applications
- Hand-Held Devices

General Description

The AT1780 is a current-mode step-up DC/DC converter with a 1.6A, 0.21 Ω power MOSFET. The soft-start function is programmed with an external capacitor, which sets the input current ramp rate. It is ideal for generating bias voltages for LCD panels. Pin selectable frequency 640KHz or 1.2MHz operation results in a low noise output that is easy to filter and faster loop performance. An external compensation pin provides the user flexibility in determining loop dynamics, allowing the use of small, low equivalent series resistance (ESR) ceramic output capacitors.

**Protected by U.S. Patent # 6,791,368*

Block Diagram

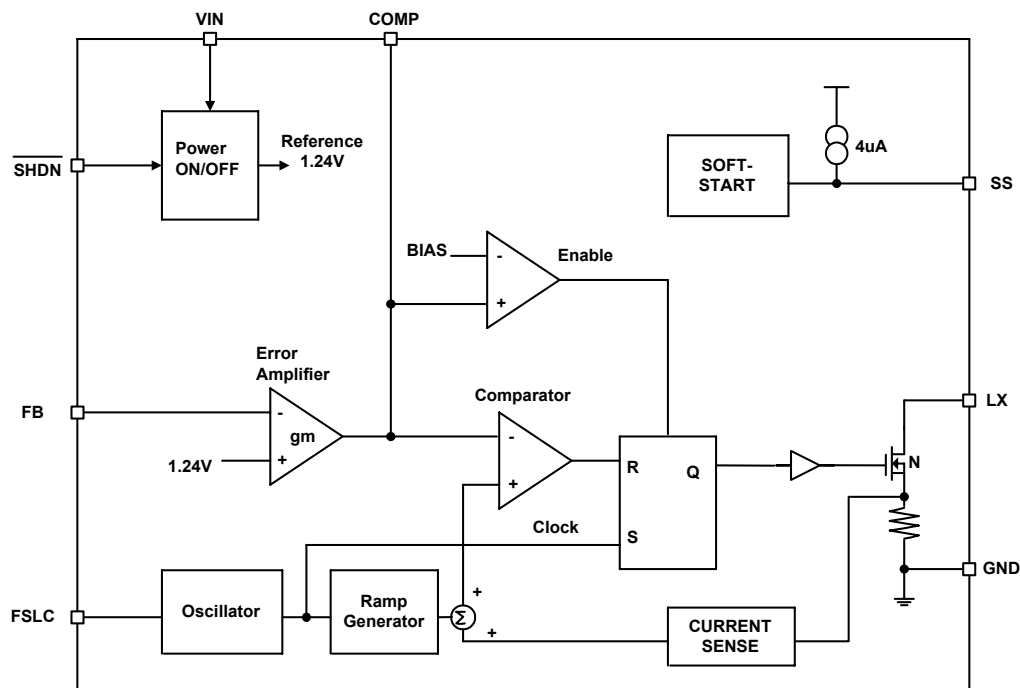

Aimtron reserves the right without notice to change this circuitry and specifications.

Pin Configuration

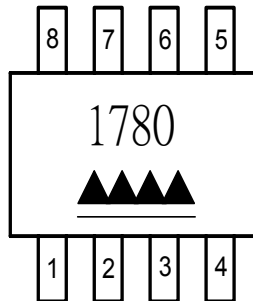

Ordering Information

Part number	Package	Marking
AT1780M GRE	MSOP8,Green	1780,data code with one bottom line

**For more marking information, contact our sales representative directly*

Pin Description

Pin No.	Symbol	I/O	Description
1	COMP	-	Compensation network connection.
2	FB	I	Output voltage feedback input
3	/SHDN	I	Shutdown control input, active low
4	GND	-	Ground
5	LX	O	Switch Pin.
6	VIN	-	Power supply pin.
7	FSLC	I	Frequency select input. Ground=640KHz, VIN=1.2MHz
8	SS	—	Soft-Start control pin.

Absolute Maximum Ratings

Parameter	Condition	Rated Value		Unit
		Min.	Max.	
LX to GND	—	-0.3	+14	V
IN, /SHDN, FREG, FB to GND	—	-0.3	+6	V
SS, COMP to GND	—	-0.3	V _{IN} +0.3	V
RMS LX pin current	—	—	1.2	A
Continuous power dissipation	8pin μ MAX (TA=+70°C)	—	330	mW
Operating temperature	—	-30	+85	°C
Junction temperature	—	—	+150	°C
Storage temperature	—	-40	+150	°C
Lead temperature	—	—	+300	°C

Stresses beyond those listed under “Absolute Maximum Ratings” may cause permanent damage to the device. These are stress ratings only, and functional operation of the device at these or any other conditions beyond those indicated in the operational sections of the specifications is not implied. Exposure to absolute maximum rating conditions for extended periods may affect device reliability.

Recommended Operating Conditions

(Ta=+25°C)

Parameter	Symbol	Values			Unit
		Min.	Typ.	Max.	
Power supply voltage	V _{IN}	2.6	--	5.5	V
SS pin capacitance	C _{PE}	--	0.033	--	μ F
Phase compensation capacitance	C _{COMP1}	--	470	--	pF
Phase compensation capacitance	C _{COMP2}	--	18	--	pF
Phase compensation resistance	R _{COMP}	--	30	--	K Ω
Oscillation frequency	f _{OSC1}	540	640	740	kHz
	f _{OSC2}	1000	1220	1500	
Operating temperature	T _{OP}	-30	+25	+85	°C

Electrical Characteristics

(VIN = SHDN = 3V, FREQ = GND, TA = 0°C to +85°C, unless otherwise noted. Typical values are at TA = +25°C.)

Parameter	Symbol	Condition	Values			Unit	
			Min.	Typ.	Max.		
Entire device	Input Supply Range	V _{IN}	2.6		5.5	V	
	V _{IN} Undervoltage Lockout	UVLO	V _{IN} rising, typical hysteresis is 40mV, LX remains off below this level		2.1 2.3 2.5	V	
	Quiescent Current	I _{IN}	V _{FB} = 1.3V, not switching		0.218	0.35	mA
			V _{FB} = 1.0V, switching		2.045	5	
Shutdown Supply Current	I _{IN}	/SHDN = GND		0.1	10	μA	
Error amplifier	Feedback Voltage	V _{FB}	Level to produce V _{COMP} = 1.24V		1.222 1.24 1.258	V	
	FB Input Bias Current	I _{FB}	V _{FB} = 1.25V			0 40	nA
	Feedback-Voltage Line Regulation		Level to produce V _{COMP} = 1.24V, 2.6V < V _{IN} < 5.5V			0.05 0.15	%/V
	Transconductance	gm	ΔI = 5μA			140	μmhos
	Voltage Gain	A _v	--			500	V/V
Sawtooth wave oscillator (OSC)	Frequency	f _{osc}	FSLC = GND	540	640	740	kHz
			FSLC = IN	1050	1200	1350	
	Maximum Duty Cycle	DC	FSLC = GND	79	91.3	92	%
FSLC = IN				82.1			
N-CHANNEL SWITCH	Current Limit	I _{LIM}	V _{FB} = 1V, duty cycle = 65%		1.2 1.6 2.3	A	
	On-Resistance	R _{ON}	I _{LX} = 1.2A			0.21 0.5	Ω
	Leakage Current	I _{LXOFF}	V _{LX} = 12V			0.01 20	μA
	Current-Sense Transresistance	R _{CS}		0.3	0.45	0.65	V/A
SOFT-START	Reset Switch Resistance					100	Ω
	Charge Current		V _{SS} = 1.2V		1.5 4 7	μA	
CONTROL INPUTS	Input Low Voltage	V _{IL}	/SHDN, FREQ; V _{IN} = 2.6V to 5.5V			0.4	V
	Input High Voltage	V _{IH}	/SHDN, FREQ; V _{IN} = 2.6V to 5.5V		1.6		V
	Hysteresis		SHDN, FREQ		100		mV
	FSLC Pull-Down Current	I _{FSLC}		1.5	5	9	μA
	/SHDN Input Current	I _{SHDN}			0.001	1	μA

Typical Characteristics

(VIN = 3.3V, FREQ = GND, TA=25°C, unless otherwise noted.)

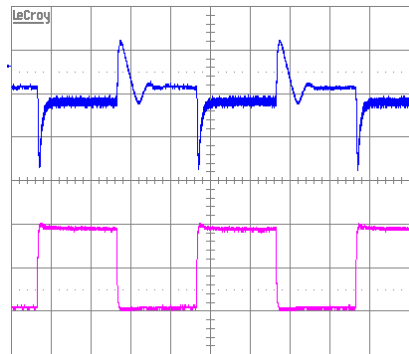
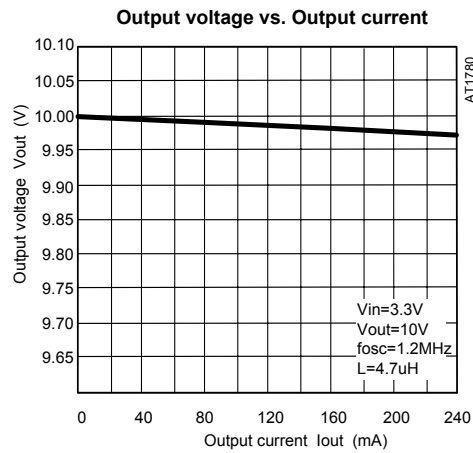
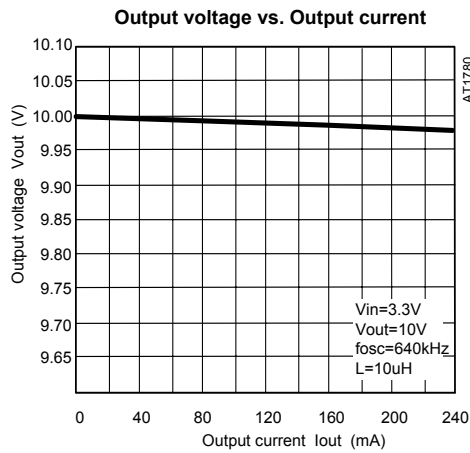
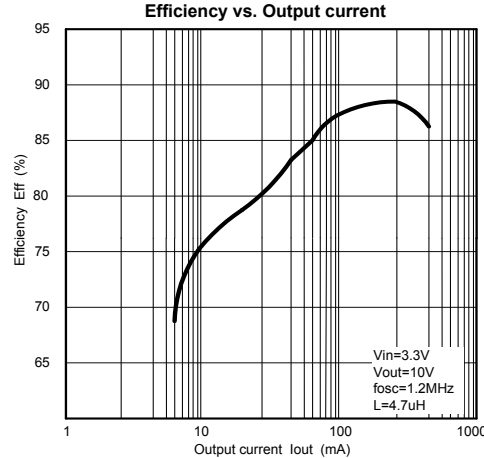
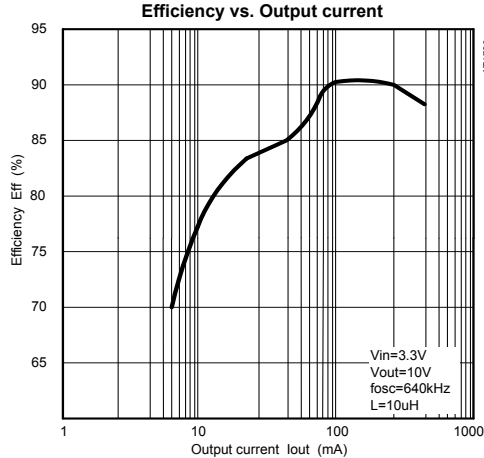

CH1: Output voltage, 100mV/div/AC
CH4: Output current, 100mA/div/DC
Vout=10V, fosc=640kHz, L=10uH
R1=100k, C1=470PF, C2=18PF

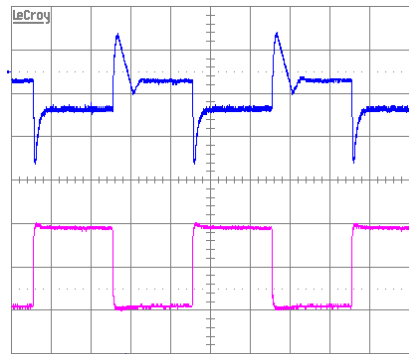

CH1: Output voltage, 100mV/div/AC
CH4: Output current, 100mA/div/DC
Vout=10V, fosc=1.2MHz, L=4.7uH
R1=100k, C1=470PF, C2=18PF

Typical Characteristics (continued)

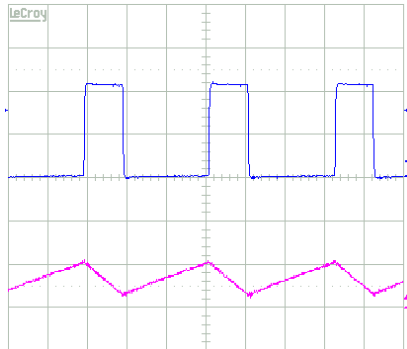

CH1:LX voltage,5V/div/DC
 CH4:Inductor current,500mA/div/DC
 Vout=10V,fosc=640kHz,L=10uH

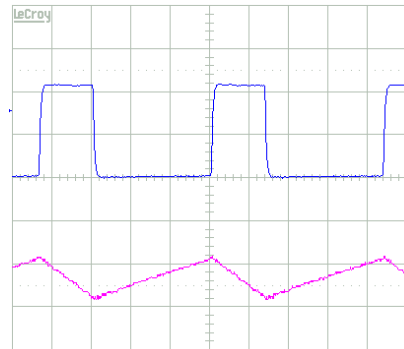

CH1:LX voltage,5V/div/DC
 CH4:Inductor current,500mA/div/DC
 Vout=10V,fosc=1.2MHz,L=4.7uH

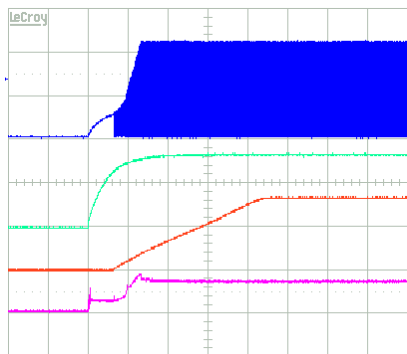

CH1:LX voltage,5V/div/DC
 CH2:Vin and /SHDN voltage,2V/div/DC
 CH3:SS voltage,2V/div/DC
 CH4:lin current,500mA/div/DC
 Vout=10V,Iout=100mA,
 fosc=640kHz,L=10uH

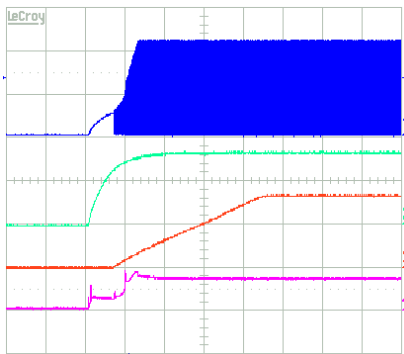

CH1:LX voltage,5V/div/DC
 CH2:Vin and /SHDN voltage,2V/div/DC
 CH3:SS voltage,2V/div/DC
 CH4:lin current,500mA/div/DC
 Vout=10V,Iout=100mA,
 fosc=1.2MHz,L=4.7uH

Typical Application Circuit

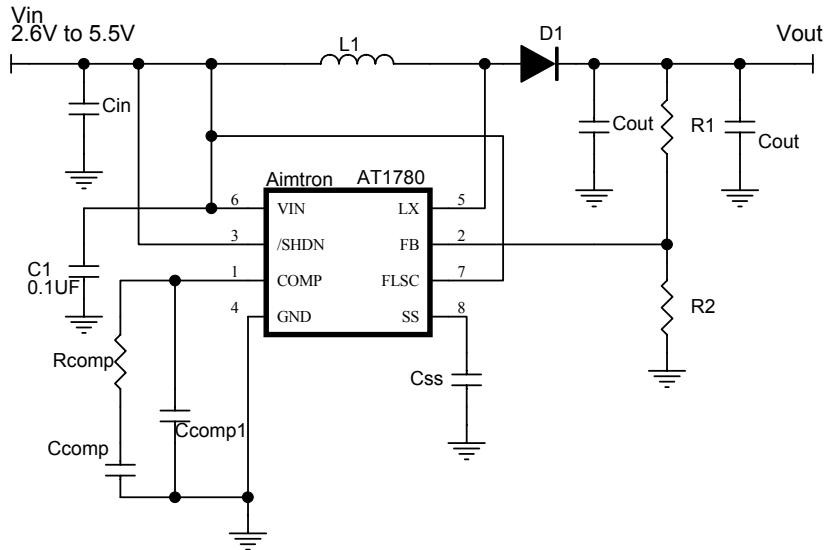

Figure 1. Typical application circuit

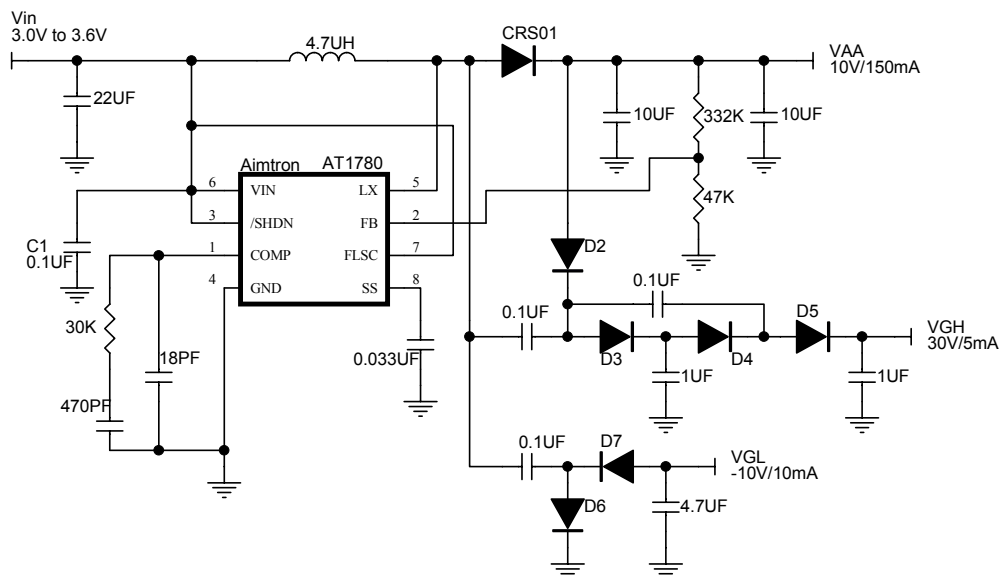
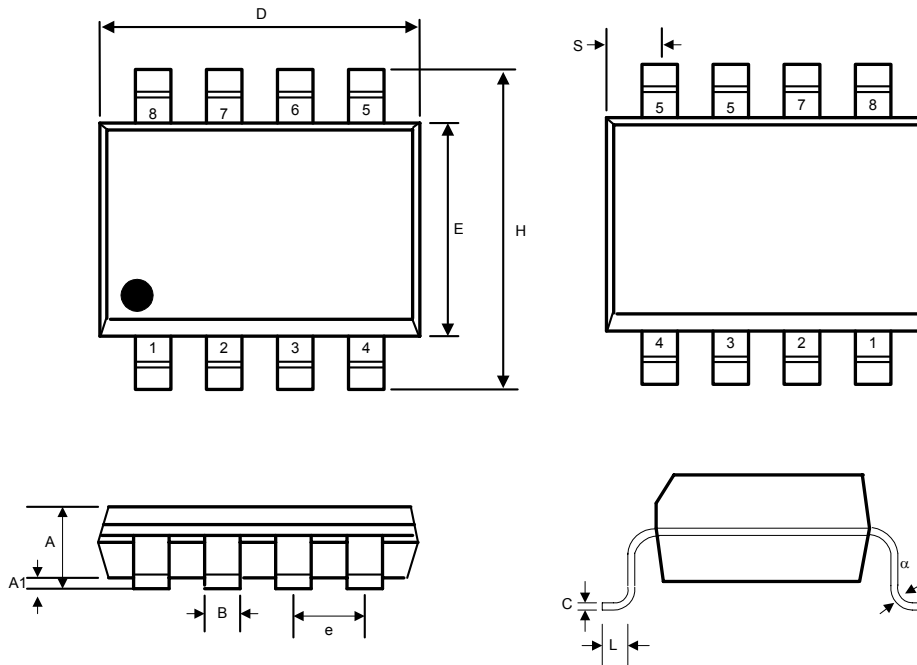

Figure 2. TFT panel power supply application circuit

Small Outline 8-pin Plastic μ MAX



SYMBOL	INCHES		MILLIMETERS		NOTES
	MIN	MAX	MIN	MAX	
A	0.037	0.043	0.94	1.10	-
A1	0.002	0.006	0.05	0.15	-
B	0.010	0.014	0.25	0.36	-
C	0.005	0.007	0.13	0.18	-
D	0.116	0.120	2.95	3.05	-
e	0.0256 BSC		0.65 BSC		-
E	0.116	0.120	2.95	3.05	-
H	0.188	0.198	4.78	5.03	-
L	0.016	0.026	0.41	0.66	-
α	0°	6°	0°	6°	-
S	0.207 BSC		0.525 BSC		-

Reflow Profiles

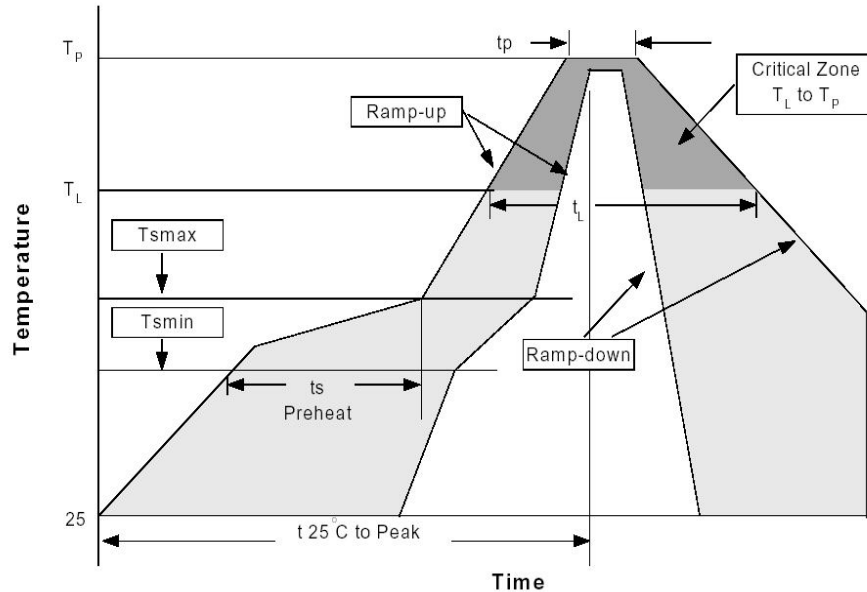

Profile Feature	Sn-Pb Eutectic Assembly		Pb-Free Assembly	
	Large Body Pkg. thickness ≥2.5mm or Pkg. volume ≥350mm ³	Small Body Pkg. thickness <2.5mm or Pkg. volume <350mm ³	Large Body Pkg. thickness ≥2.5mm or Pkg. volume ≥350mm ³	Small Body Pkg. thickness ≥2.5mm or Pkg. volume ≥350mm ³
Average ramp-up rate (T _L to T _P)	3°C/second max.		3°C/second max.	
Preheat -Temperature Min(T _{smin}) -Temperature Max (T _{smax}) -Time (min to max)(t _s)	100°C 150°C 60-120 seconds		150°C 200°C 60-180 seconds	
T _{smax} to T _L -Ramp-up Rate			3°C/second max.	
Time maintained above: -Temperature (T _L) -Time (t _L)	183°C 60-150 seconds		217°C 60-150 seconds	
Peak Temperature(T _P)	225+0/-5°C	240+0/-5°C	245+0/-5°C	250+0/-5°C
Time within 5°C of actual Peak Temperature (t _p)	10-30 seconds	10-30 seconds	10-30 seconds	20-40 seconds
Ramp-down Rate	6°C/second max.		3°C/second max.	
Time 25°C to Peak Temperature	6 minutes max.		8 minutes max.	

*All temperatures refer to topside of the package, measured on the package body surface.