

---

# HM628128B Series

1 M SRAM (128-kword × 8-bit)

# HITACHI

ADE-203-243E (Z)

Rev. 5.0

Nov. 1997

---

## Description

The Hitachi HM628128B is a CMOS static RAM organized 131,072-word × 8-bit. It realizes higher density, higher performance and low power consumption by employing 0.8 μm Hi-CMOS shrink process technology. It offers low power standby power dissipation, therefore, it is suitable for battery backup systems. The device, packaged in a 525 mil SOP or a 8 mm × 20 mm TSOP or a 600 mil plastic DIP is available.

## Features

- Single 5 V supply: 5.0 V ± 10%
- Access time: 70/75/85 ns (max)
- Power dissipation
  - Active: 50 mW/MHz (typ)
  - Standby: 10 μW (typ) (L/L-SL version)
- Completely static memory
  - No clock or timing strobe required
- Equal access and cycle times
- Common data input and output
  - Three state output
- Directly TTL compatible all inputs and outputs
- Capability of battery backup operation (L/L-SL version)
  - 2 chip selection for battery backup

---

## HM628128B Series

---

### Ordering Information

Type No.	Access time	Data retention current	Package
HM628128BLP-7	70 ns	50 $\mu$ A	600-mil 32-pin plastic DIP (DP-32)
HM628128BLP-8	85 ns	50 $\mu$ A	
HM628128BLP-7SL	70 ns	15 $\mu$ A	
HM628128BLP-8SL	85 ns	15 $\mu$ A	
HM628128BLFP-7	70 ns	50 $\mu$ A	525-mil 32-pin plastic SOP (FP-32D)
HM628128BLFP-75	75 ns	50 $\mu$ A	
HM628128BLFP-8	85 ns	50 $\mu$ A	
HM628128BLFP-7SL	70 ns	15 $\mu$ A	
HM628128BLFP-75SL	75 ns	15 $\mu$ A	
HM628128BLFP-8SL	85 ns	15 $\mu$ A	
HM628128BLT-7	70 ns	50 $\mu$ A	Normal-bend type 32-pin plastic 8 mm $\times$ 20 mm TSOP (TFP-32D)
HM628128BLT-75	75 ns	50 $\mu$ A	
HM628128BLT-8	85 ns	50 $\mu$ A	
HM628128BLT-7SL	70 ns	15 $\mu$ A	
HM628128BLT-75SL	75 ns	15 $\mu$ A	
HM628128BLT-8SL	85 ns	15 $\mu$ A	
HM628128BLR-7	70 ns	50 $\mu$ A	Reverse-bend type 32-pin plastic 8 mm $\times$ 20 mm TSOP (TFP-32DR)
HM628128BLR-8	85 ns	50 $\mu$ A	
HM628128BLR-7SL	70 ns	15 $\mu$ A	
HM628128BLR-8SL	85 ns	15 $\mu$ A	

## Pin Arrangement

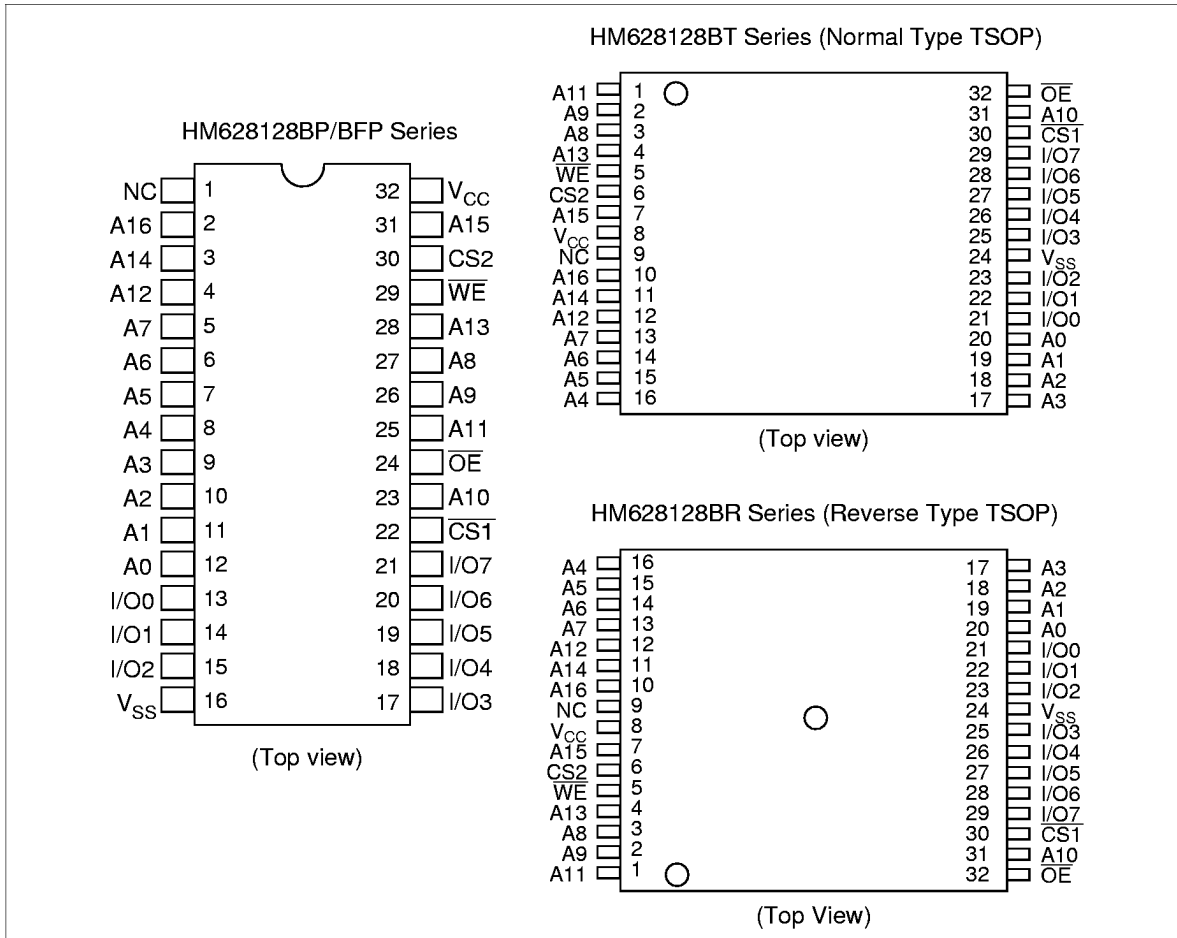

## Pin Description

Pin name	Function
A0 to A16	Address input
I/O0 to I/O7	Data input/output
CS1	Chip select 1
CS2	Chip select 2
WE	Write enable
OE	Output enable
NC	No connection
V <sub>CC</sub>	Power supply
V <sub>SS</sub>	Ground

# HM628128B Series

## Block Diagram

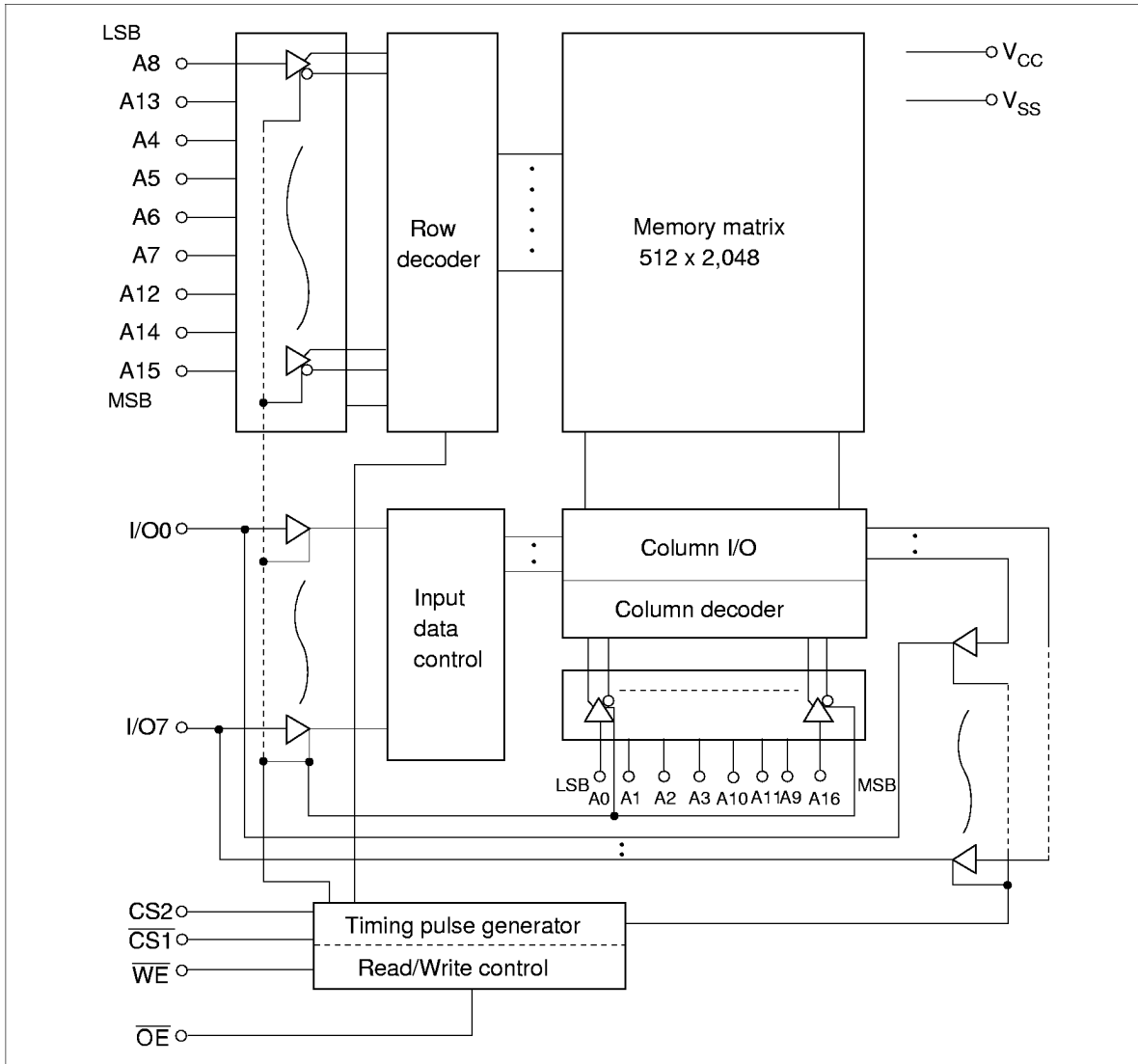

**Function Table**

$\overline{WE}$	$\overline{CS1}$	$\overline{CS2}$	$\overline{OE}$	Mode	$V_{CC}$ current	I/O pin	Ref. cycle
×	H	×	×	Standby	$I_{SB}, I_{SB1}$	High-Z	—
×	×	L	×	Standby	$I_{SB}, I_{SB1}$	High-Z	—
H	L	H	H	Output disable	$I_{CC}$	High-Z	—
H	L	H	L	Read	$I_{CC}$	Dout	Read cycle
L	L	H	H	Write	$I_{CC}$	Din	Write cycle (1)
L	L	H	L	Write	$I_{CC}$	Din	Write cycle (2)

Note: ×: H or L

**Absolute Maximum Ratings**

Parameter	Symbol	Value	Unit
Supply voltage relative to $V_{SS}$	$V_{CC}$	-0.5 to +7.0	V
Voltage on any pin relative to $V_{SS}$	$V_T$	-0.5* <sup>1</sup> to $V_{CC} + 0.3$ * <sup>2</sup>	V
Power dissipation	$P_T$	1.0	W
Operating temperature range	$T_{opr}$	0 to +70	°C
Storage temperature range	$T_{stg}$	-55 to +125	°C
Storage temperature under bias	$T_{bias}$	-10 to 85	°C

Notes: 1.  $V_T$  min: -3.0 V for pulse half-width ≤ 30 ns  
 2. Maximum voltage is 7.0 V

**Recommended DC Operating Conditions ( $T_a = 0$  to +70°C)**

Parameter	Symbol	Min	Typ	Max	Unit
Supply voltage	$V_{CC}$	4.5	5.0	5.5	V
	$V_{SS}$	0	0	0	V
Input high voltage	$V_{IH}$	2.2	—	$V_{CC} + 0.3$	V
Input low voltage	$V_{IL}$	-0.3* <sup>1</sup>	—	0.8	V

Note: 1.  $V_{IL}$  min: -3.0 V for pulse half-width ≤ 30 ns

## HM628128B Series

DC Characteristics (Ta = 0 to +70°C, V<sub>CC</sub> = 5 V ± 10%, V<sub>SS</sub> = 0 V)

Parameter	Symbol	Min	Typ* <sup>1</sup>	Max	Unit	Test conditions
Input leakage current	I <sub>Li</sub>	—	—	1	μA	V <sub>in</sub> = V <sub>SS</sub> to V <sub>CC</sub>
Output leakage current	I <sub>Lo</sub>	—	—	1	μA	$\overline{CS1} = V_{IH}$ or $CS2 = V_{IL}$ or $\overline{OE} = V_{IH}$ or $\overline{WE} = V_{IL}$ , V <sub>I/O</sub> = V <sub>SS</sub> to V <sub>CC</sub>
Operating current	I <sub>CC</sub>	—	15	25	mA	$\overline{CS1} = V_{IL}$ , CS2 = V <sub>IH</sub> , Others = V <sub>IH</sub> /V <sub>IL</sub> , I <sub>I/O</sub> = 0 mA
Average operating current	I <sub>CC1</sub>	—	35	70	mA	Min cycle, duty = 100%, $\overline{CS1} = V_{IL}$ , CS2 = V <sub>IH</sub> , Others = V <sub>IH</sub> /V <sub>IL</sub> , I <sub>I/O</sub> = 0 mA
	I <sub>CC2</sub>	—	10	20	mA	Cycle time = 1 μs, duty = 100%, I <sub>I/O</sub> = 0 mA, $\overline{CS1} \leq 0.2$ V, CS2 ≥ V <sub>CC</sub> - 0.2 V, Others = V <sub>IH</sub> /V <sub>IL</sub> , V <sub>IH</sub> ≥ V <sub>CC</sub> - 0.2 V, V <sub>IL</sub> ≤ 0.2 V
Standby current	I <sub>SB</sub>	—	1	2	mA	CS2 = V <sub>IL</sub> or $\overline{CS1} = V_{IH}$ , CS2 = V <sub>IH</sub>
	I <sub>SB1</sub>	—	2* <sup>2</sup>	100* <sup>2</sup>	μA	0 V ≤ V <sub>in</sub> ≤ V <sub>CC</sub> (1) 0 V ≤ CS2 ≤ 0.2 V or (2) $\overline{CS1} \geq V_{CC} - 0.2$ V, CS2 ≥ V <sub>CC</sub> - 0.2 V
	I <sub>SB1</sub>	—	2* <sup>3</sup>	50* <sup>3</sup>	μA	
Output high voltage	V <sub>OL</sub>	—	—	0.4	V	I <sub>OL</sub> = 2.1 mA
Output low voltage	V <sub>OH</sub>	2.4	—	—	V	I <sub>OH</sub> = -1.0 mA

Notes: 1. Typical values are at V<sub>CC</sub> = 5.0 V, Ta = +25°C and not guaranteed.

2. This characteristic is guaranteed only for L version.

3. This characteristic is guaranteed only for L-SL version.

Capacitance (Ta = 25°C, f = 1.0 MHz)

Parameter	Symbol	Min	Typ	Max	Unit	Test conditions
Input capacitance* <sup>1</sup>	C <sub>in</sub>	—	—	8	pF	V <sub>in</sub> = 0 V
Input/output capacitance* <sup>1</sup>	C <sub>I/O</sub>	—	—	10	pF	V <sub>I/O</sub> = 0 V

Note: 1. This parameter is sampled and not 100% tested.

## HM628128B Series

### AC Characteristics (Ta = 0 to +70°C, V<sub>CC</sub> = 5.0 V ±10%)

#### Test Conditions

- Input pulse levels: 0.8 V to 2.4 V
- Input rise and fall time: 5 ns
- Input and output timing reference levels: 1.5 V
- Output load: 1 TTL Gate and C<sub>L</sub> (100 pF) (Including scope and jig)

#### Read Cycle

Parameter	Symbol	HM628128B						Unit	Notes
		-7		-75		-8			
		Min	Max	Min	Max	Min	Max		
Read cycle time	t <sub>RC</sub>	70	—	75	—	85	—	ns	
Address access time	t <sub>AA</sub>	—	70	—	75	—	85	ns	
Chip selection to output valid	t <sub>CO1</sub>	—	70	—	75	—	85	ns	
	t <sub>CO2</sub>	—	70	—	75	—	85	ns	
Output enable to output valid	t <sub>OE</sub>	—	35	—	35	—	45	ns	
Chip selection to output in low-Z	t <sub>LZ1</sub>	10	—	10	—	10	—	ns	2, 3
	t <sub>LZ2</sub>	10	—	10	—	10	—	ns	
Output enable to output in low-Z	t <sub>OLZ</sub>	5	—	5	—	5	—	ns	2, 3
Chip deselection to output in high-Z	t <sub>HZ1</sub>	0	25	0	25	0	30	ns	1, 2, 3
	t <sub>HZ2</sub>	0	25	0	25	0	30	ns	
Output disable to output in high-Z	t <sub>OHZ</sub>	0	25	0	25	0	30	ns	1, 2, 3
Output hold from address change	t <sub>OH</sub>	10	—	10	—	10	—	ns	

## HM628128B Series

### Write Cycle

Parameter	Symbol	HM628128B						Unit	Notes
		-7		-75		-8			
		Min	Max	Min	Max	Min	Max		
Write cycle time	$t_{WC}$	70	—	75	—	85	—	ns	
Chip selection to end of write	$t_{CW}$	60	—	60	—	75	—	ns	5
Address setup time	$t_{AS}$	0	—	0	—	0	—	ns	6
Address valid to end of write	$t_{AW}$	60	—	60	—	75	—	ns	
Write pulse width	$t_{WP}$	50	—	50	—	55	—	ns	4, 13
Write recovery time	$t_{WR}$	0	—	0	—	0	—	ns	7
Write to output in high-Z	$t_{WHZ}$	0	25	0	25	0	30	ns	1, 2, 8
Data to write time overlap	$t_{DW}$	30	—	30	—	35	—	ns	
Data hold from write time	$t_{DH}$	0	—	0	—	0	—	ns	
Output active from end of write	$t_{OW}$	5	—	5	—	5	—	ns	2
Output disable to output in High-Z	$t_{OHZ}$	0	25	0	25	0	30	ns	1, 2, 8

Notes: 1.  $t_{HZ}$ ,  $t_{OHZ}$  and  $t_{WHZ}$  are defined as the time at which the outputs achieve the open circuit conditions and are not referred to output voltage levels.

2. This parameter is sampled and not 100% tested.
3. At any given temperature and voltage condition,  $t_{HZ}$  max is less than  $t_{LZ}$  min both for a given device and from device to device.
4. A write occurs during the overlap of a low  $\overline{CS1}$ , a high CS2, and a low  $\overline{WE}$ . A write begins at the latest transition among  $\overline{CS1}$  going low, CS2 going high, and  $\overline{WE}$  going low. A write ends at the earliest transition among  $\overline{CS1}$  going high, CS2 going low, and  $\overline{WE}$  going high.  $t_{WP}$  is measured from the beginning of write to the end of write.
5.  $t_{CW}$  is measured from the later of  $\overline{CS1}$  going low or CS2 going high to the end of write.
6.  $t_{AS}$  is measured from the address valid to the beginning of write.
7.  $t_{WR}$  is measured from the earliest of  $\overline{CS1}$  or  $\overline{WE}$  going high or CS2 going low to the end of write cycle.
8. During this period, I/O pins are in the output state; therefore, the input signals of the opposite phase to the outputs must not be applied.
9. If  $\overline{CS1}$  goes low simultaneously with  $\overline{WE}$  going low or after  $\overline{WE}$  going low, the outputs remain in a high impedance state.
10. Dout is the same phase of the latest written data in this write cycle.
11. Dout is the read data of next address.
12. If  $\overline{CS1}$  is low and CS2 high during this period, I/O pins are in the output state. Therefore, the input signals of the opposite phase to the outputs must not be applied to them.
13. In the write cycle with  $\overline{OE}$  low fixed,  $t_{WP}$  must satisfy the following equation to avoid a problem of data bus contention.
 
$$t_{WP} \geq t_{DW} \text{ min} + t_{WHZ} \text{ max}$$



Timing Waveform

Read Timing Waveform ( $\overline{WE} = V_{IH}$ )

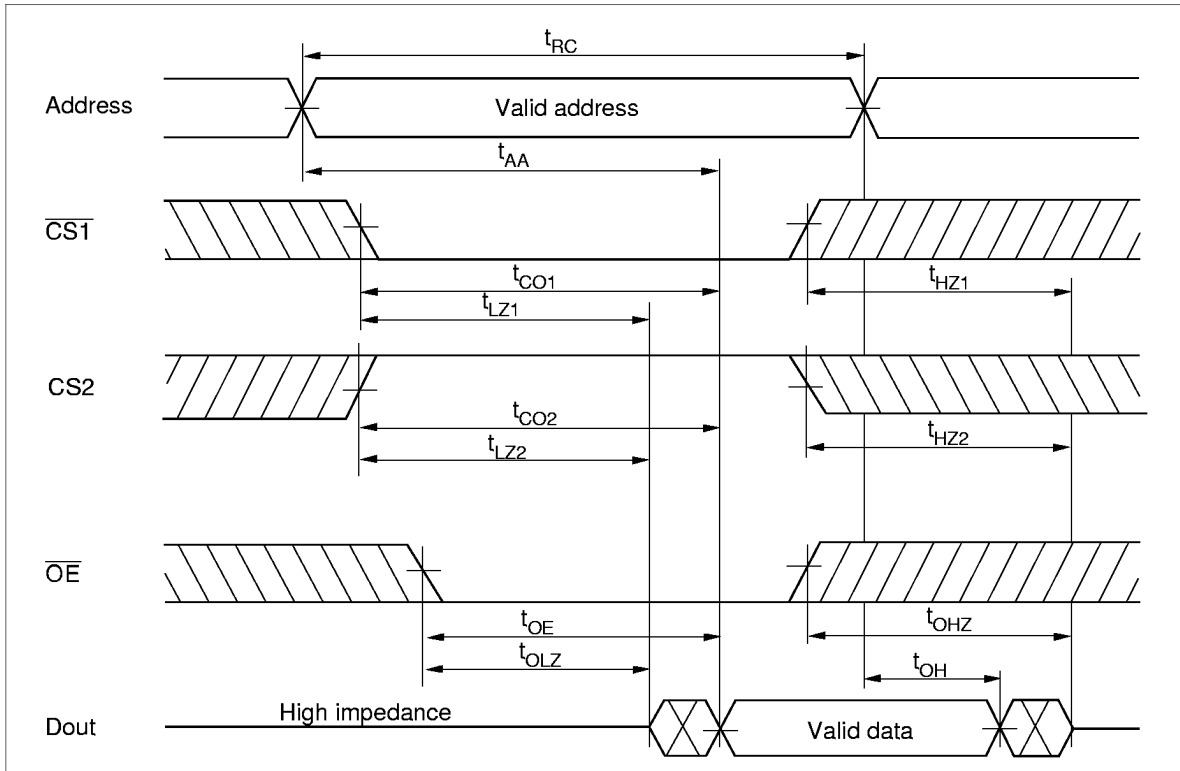

## HM628128B Series

### Write Timing Waveform (1) ( $\overline{\text{OE}}$ Clock)

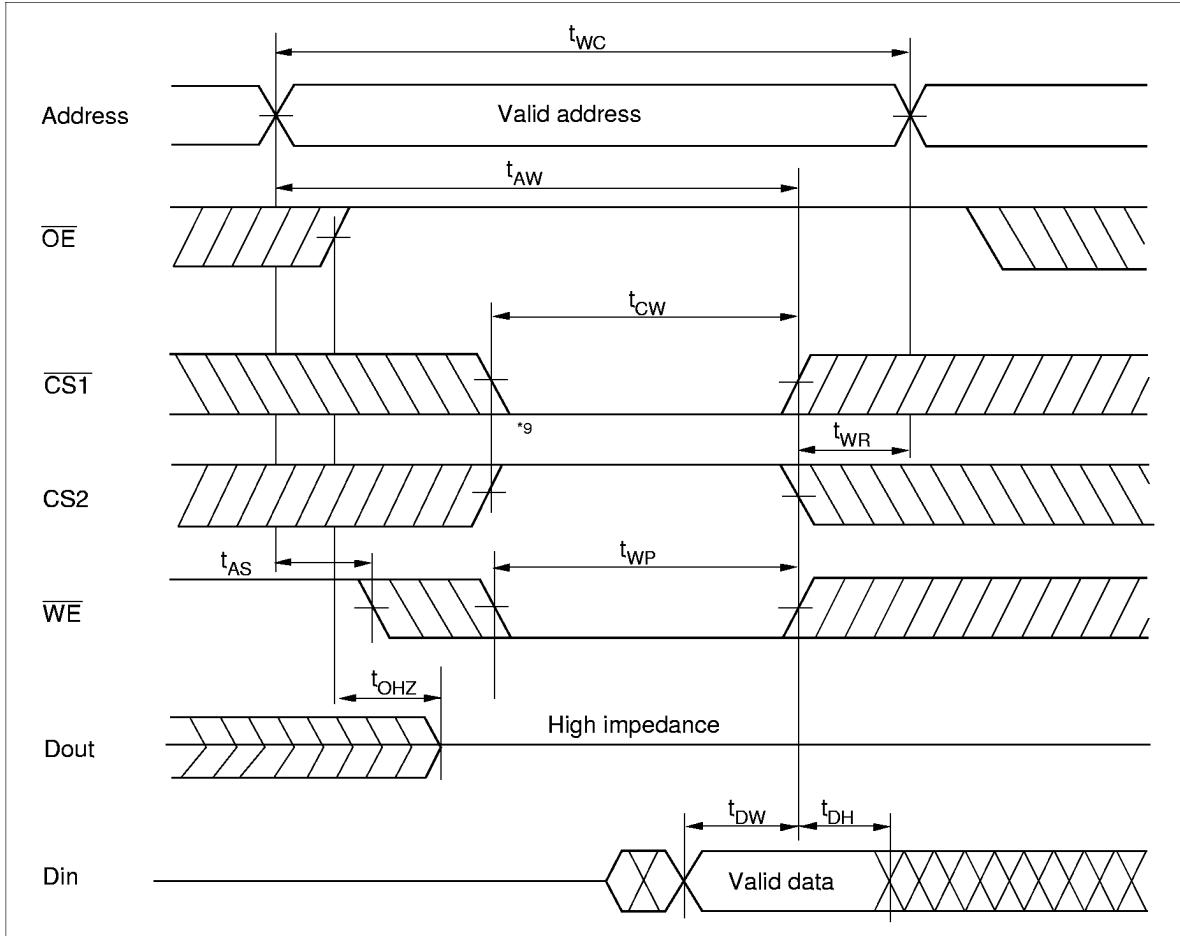

Write Timing Waveform (2) ( $\overline{OE}$  Low Fixed)

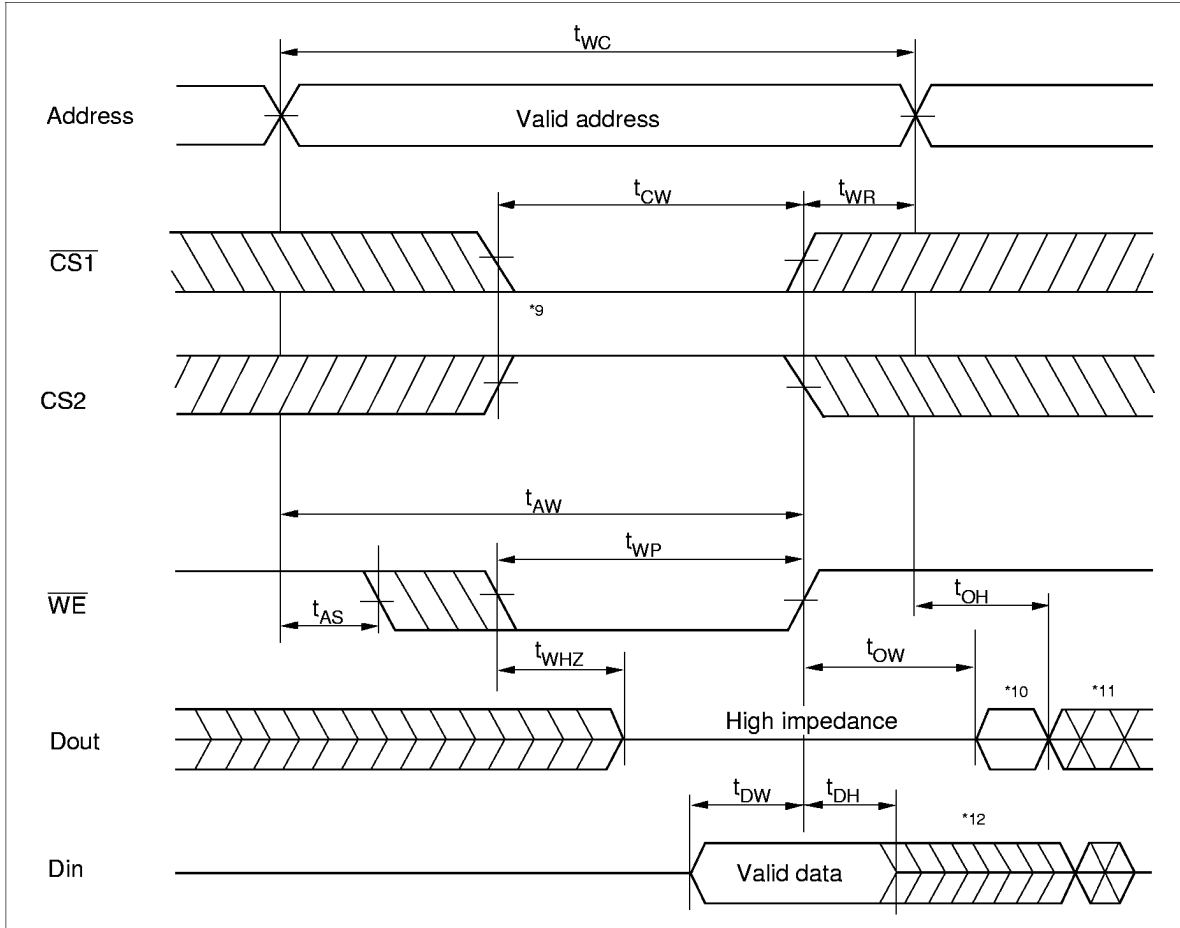

## HM628128B Series

### Low $V_{CC}$ Data Retention Characteristics ( $T_a = 0$ to $+70^\circ\text{C}$ )

Parameter	Symbol	Min	Typ <sup>*4</sup>	Max	Unit	Test conditions <sup>3</sup>
$V_{CC}$ for data retention	$V_{DR}$	2.0	—	—	V	$0\text{V} \leq V_{in} \leq V_{CC}$ (1) $0\text{V} \leq CS2 \leq 0.2\text{V}$ or (2) $CS2 \geq V_{CC} - 0.2\text{V}$ $\overline{CS1} \geq V_{CC} - 0.2\text{V}$
Data retention current	$I_{CCDR}$	—	1	$50^{*1}$	$\mu\text{A}$	$V_{CC} = 3.0\text{V}$ , $0\text{V} \leq V_{in} \leq V_{CC}$ (1) $0\text{V} \leq CS2 \leq 0.2\text{V}$ or (2) $CS2 \geq V_{CC} - 0.2\text{V}$ , $\overline{CS1} \geq V_{CC} - 0.2\text{V}$
	$I_{CCDR}$	—	1	$15^{*2}$	$\mu\text{A}$	
Chip deselect to data retention time	$t_{CDR}$	0	—	—	ns	See retention waveform
Operation recovery time	$t_R$	5	—	—	ms	

- Notes:
1. This characteristic is guaranteed only for L version,  $20\ \mu\text{A}$  max. at  $T_a = 0$  to  $40^\circ\text{C}$ .
  2. This characteristic is guaranteed only for L-SL version,  $3\ \mu\text{A}$  max. at  $T_a = 0$  to  $40^\circ\text{C}$ .
  3. CS2 controls address buffer,  $\overline{WE}$  buffer,  $\overline{CS1}$  buffer,  $\overline{OE}$  buffer, and Din buffer. If CS2 controls data retention mode,  $V_{in}$  levels (address,  $\overline{WE}$ ,  $\overline{OE}$ ,  $\overline{CS1}$ , I/O) can be in the high impedance state. If  $\overline{CS1}$  controls data retention mode, CS2 must be  $CS2 \geq V_{CC} - 0.2\text{V}$  or  $0\text{V} \leq CS2 \leq 0.2\text{V}$ . The other input levels (address,  $\overline{WE}$ ,  $\overline{OE}$ , I/O) can be in the high impedance state.
  4. Typical values are at  $V_{CC} = 3.0\text{V}$ ,  $T_a = +25^\circ\text{C}$  and not guaranteed.

**Low  $V_{CC}$  Data Retention Timing Waveform (1) ( $\overline{CS1}$  Controlled)**

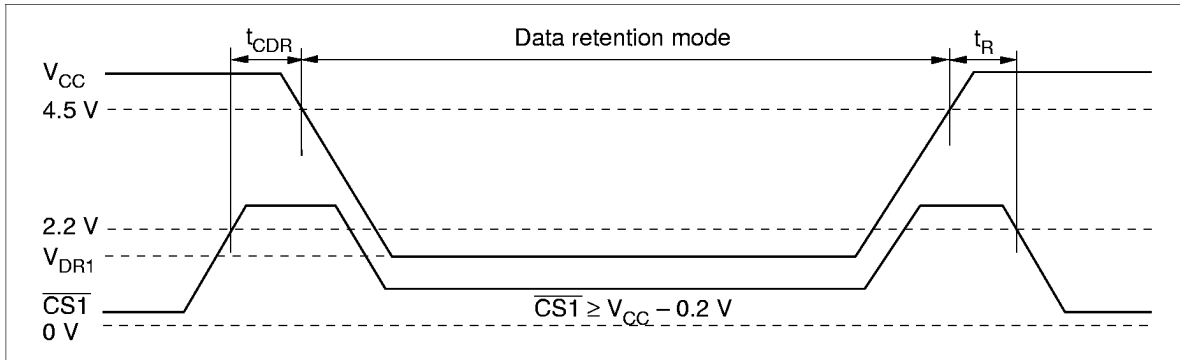

**Low  $V_{CC}$  Data Retention Timing Waveform (2) ( $CS2$  Controlled)**

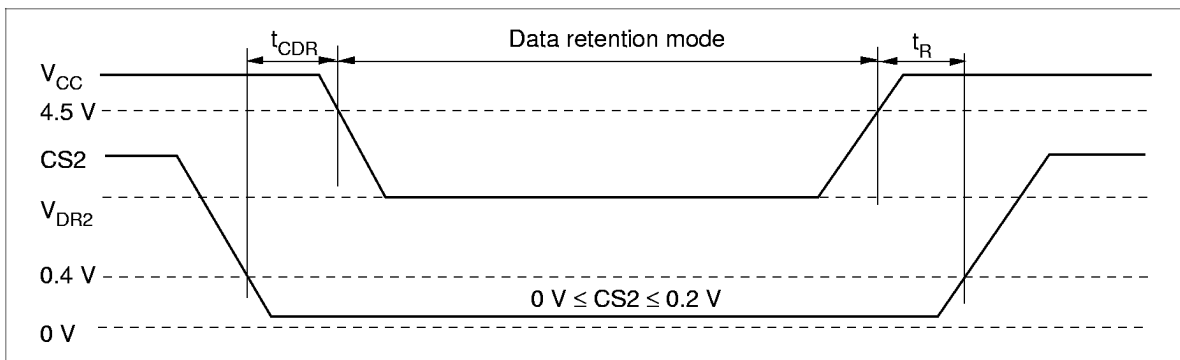

# HM628128B Series

## Package Dimensions

### HM628128BLP Series (DP-32)

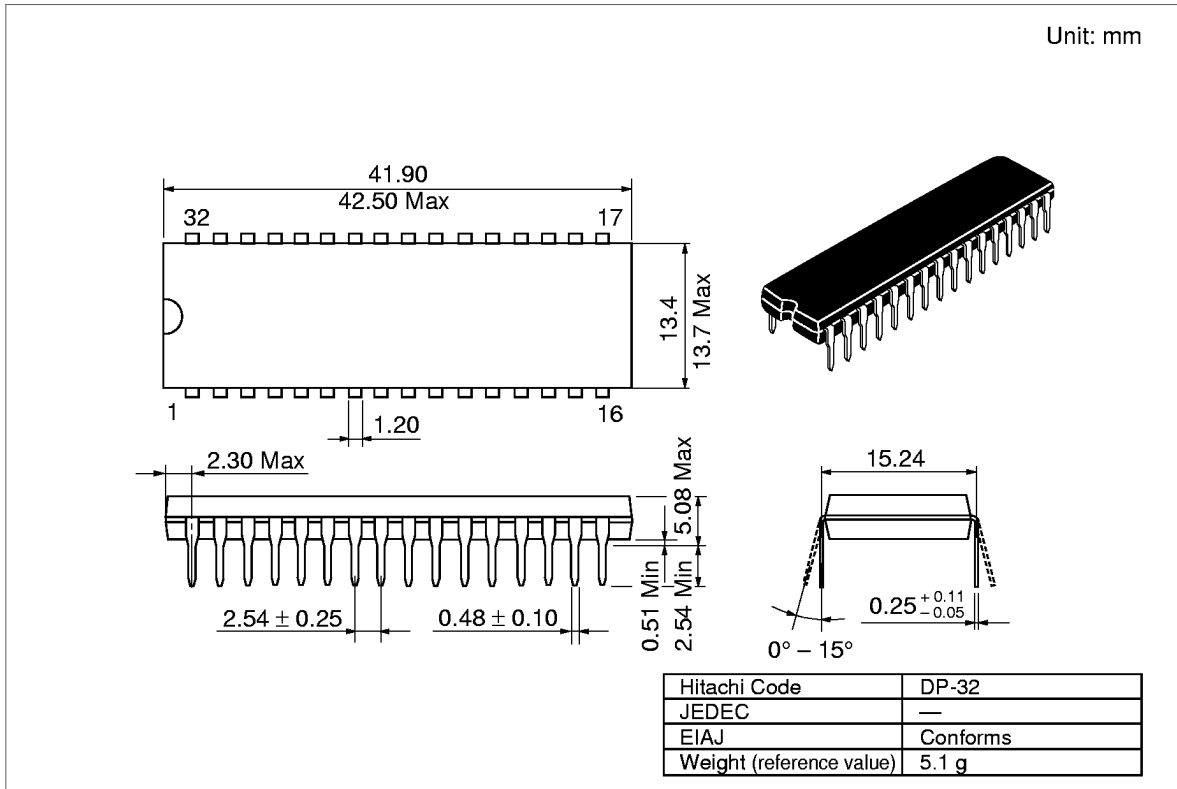

# HM628128B Series

## Package Dimensions (cont.)

### HM628128BLFP Series (FP-32D)

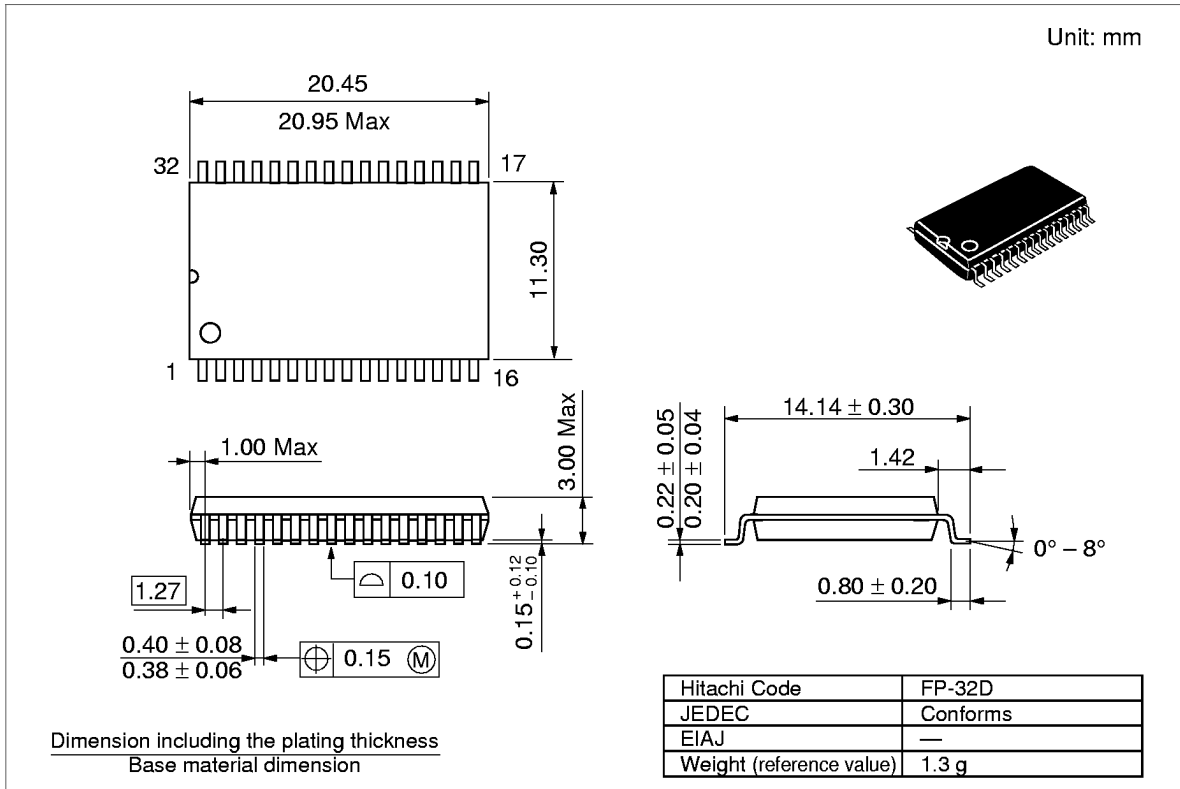

# HM628128B Series

## Package Dimensions (cont.)

### HM628128BLT Series (TFP-32D)

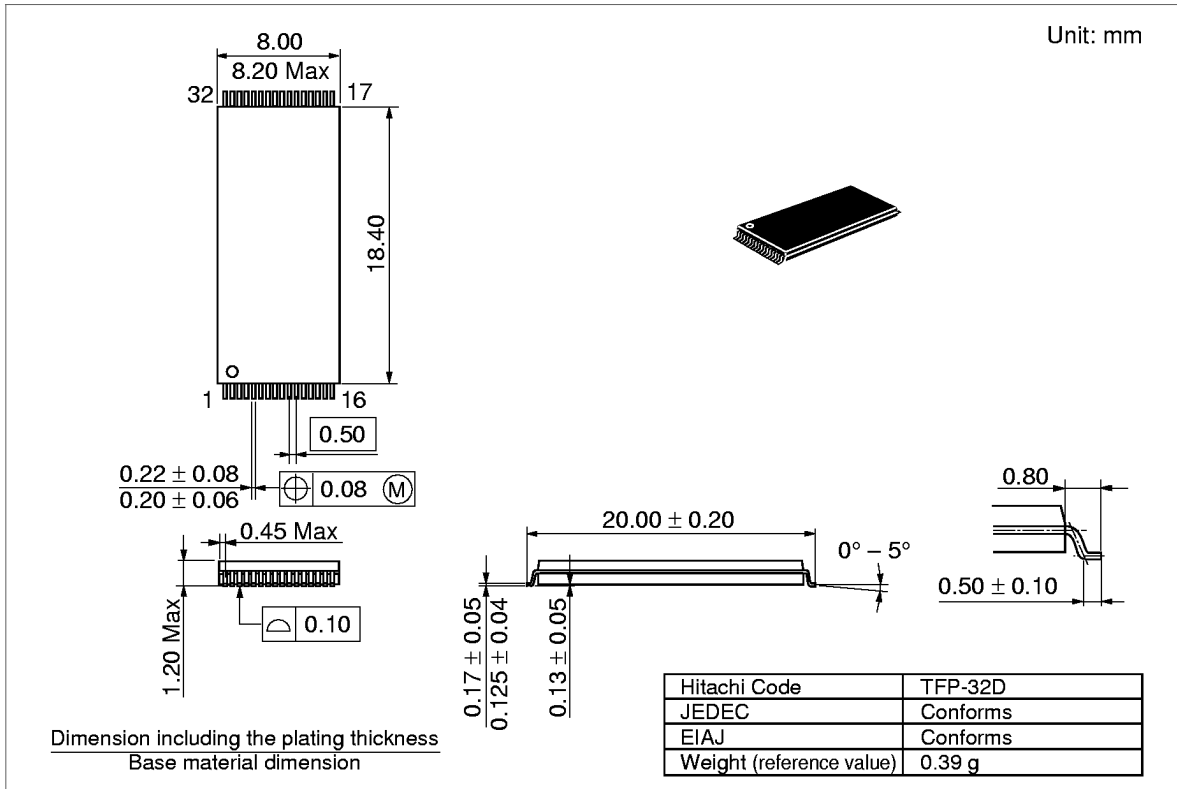



# HM628128B Series

## Package Dimensions (cont.)

### HM628128BLR Series (TFP-32DR)

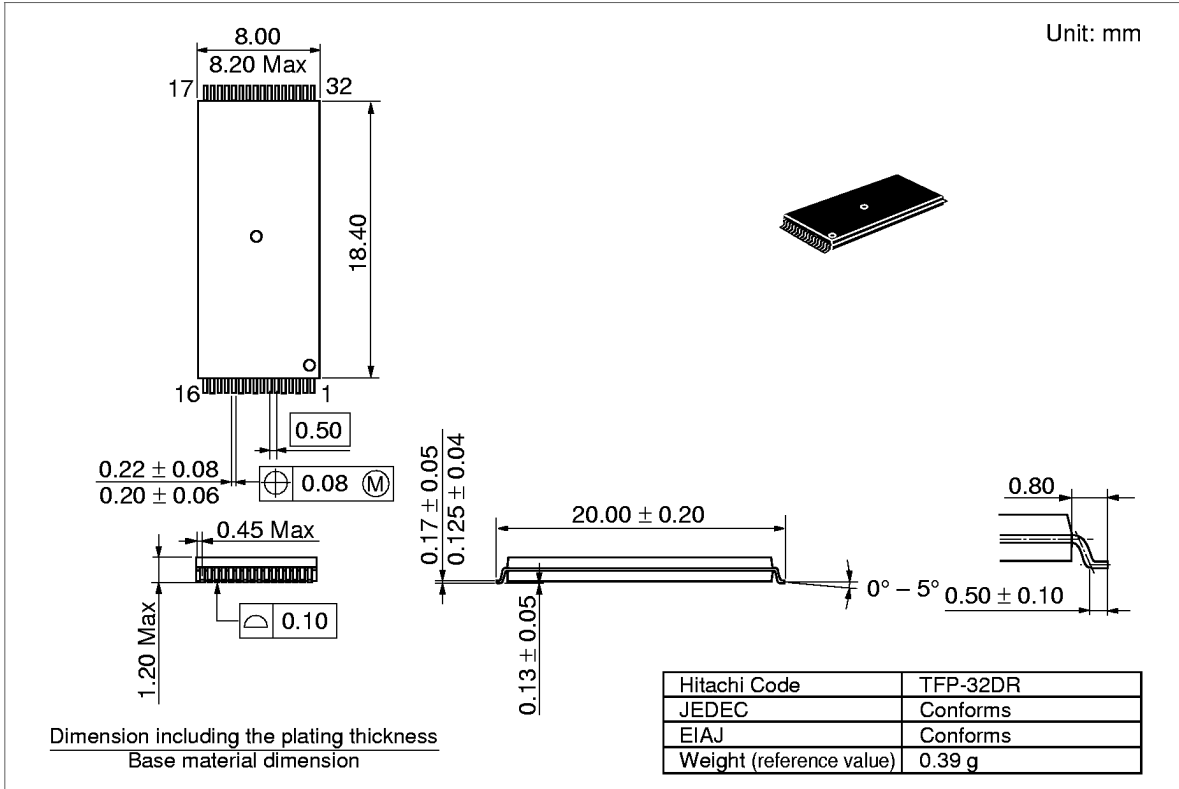

---

## HM628128B Series

---

When using this document, keep the following in mind:

1. This document may, wholly or partially, be subject to change without notice.
2. All rights are reserved: No one is permitted to reproduce or duplicate, in any form, the whole or part of this document without Hitachi's permission.
3. Hitachi will not be held responsible for any damage to the user that may result from accidents or any other reasons during operation of the user's unit according to this document.
4. Circuitry and other examples described herein are meant merely to indicate the characteristics and performance of Hitachi's semiconductor products. Hitachi assumes no responsibility for any intellectual property claims or other problems that may result from applications based on the examples described herein.
5. No license is granted by implication or otherwise under any patents or other rights of any third party or Hitachi, Ltd.
6. **MEDICAL APPLICATIONS:** Hitachi's products are not authorized for use in **MEDICAL APPLICATIONS** without the written consent of the appropriate officer of Hitachi's sales company. Such use includes, but is not limited to, use in life support systems. Buyers of Hitachi's products are requested to notify the relevant Hitachi sales offices when planning to use the products in **MEDICAL APPLICATIONS**.

---

---

# HITACHI

## Hitachi, Ltd.

Semiconductor & IC Div.  
Nippon Bldg., 2-6-2, Ohte-machi, Chiyoda-ku, Tokyo 100, Japan  
Tel: Tokyo (03) 3270-2111  
Fax: (03) 3270-5109

### For further information write to:

Hitachi America, Ltd.  
Semiconductor & IC Div.  
2000 Sierra Point Parkway  
Brisbane, CA. 94005-1835  
U S A  
Tel: 415-589-8300  
Fax: 415-583-4207

Hitachi Europe GmbH  
Continental Europe  
Dornacher Straße 3  
D-85622 Feldkirchen  
München  
Tel: 089-9 91 80-0  
Fax: 089-9 29 30-00

Hitachi Europe Ltd.  
Electronic Components Div.  
Northern Europe Headquarters  
Whitebrook Park  
Lower Cookham Road  
Maidenhead  
Berkshire SL6 8YA  
United Kingdom  
Tel: 01628-585000  
Fax: 01628-585160

Hitachi Asia Pte. Ltd.  
16 Collyer Quay #20-00  
Hitachi Tower  
Singapore 049318  
Tel: 535-2100  
Fax: 535-1533

Hitachi Asia (Hong Kong) Ltd.  
Unit 706, North Tower,  
World Finance Centre,  
Harbour City, Canton Road  
Tsim Sha Tsui, Kowloon  
Hong Kong  
Tel: 27359218  
Fax: 27306071

Copyright © Hitachi, Ltd., 1997. All rights reserved. Printed in Japan.

---

---

## HM628128B Series

---

### Revision Record

Rev.	Date	Contents of Modification	Drawn by	Approved by
0.0	Oct. 5, 1994	Initial issue	M. Higuchi	K. Yoshizaki
1.0	Dec. 20, 1994	DC Characteristics $I_{CC}$ max: 15 mA to 25 mA $I_{CC2}$ typ: 5 mA to 10 mA $I_{CC2}$ max: 10 mA to 20 mA	M. Higuchi	K. Yoshizaki
2.0	Mar. 20, 1995	Low Vcc Data Retention Characteristics Addition of note 3: typical values at $V_{CC} = 3.0$ V, $T_a = +25^\circ\text{C}$ and not guaranteed	M. Higuchi	K. Yoshizaki
3.0	Aug. 10, 1996	Change of format Addition of HM628128B-10/10SL Series AC Characteristics Change order of note.	M. Higuchi	K. Yoshizaki
4.0	Jul. 1, 1997	Addition of HM628128B-75 Series DC Characteristics $V_{OH}$ Test condition: $-0.1$ mA to $-1.0$ mA	M. Higuchi	K. Imato
5.0	Nov. 1997	Change of Subtitle		

---