

Preliminary

FEATURES

- 25, 45 ns Read Access and R/W Cycle Time
- Unlimited Read/Write Endurance
- Automatic Non-volatile STORE on Power Loss
- Non-Volatile STORE Under Hardware or Software Control
- Automatic RECALL to SRAM on Power Up
- Unlimited RECALL Cycles
- 1 Million STORE Endurance
- 20-Year Non-volatile Data Retention
- Single 3.0V +20%, -10% Operation
- Commercial, Industrial Temperatures
- 54-pin 400-mil TSOPII Package (RoHS-Compliant)
- 48-ball Fine Pitch Ball Grid Array (FBGA)

DESCRIPTION

The Simtek STK14EE16 is an 8MB fast static RAM with a non-volatile Quantum Trap storage element included with each memory cell.

The SRAM provides the fast access & cycle times, ease of use and unlimited read & write endurance of a normal SRAM.

Data transfers automatically to the non-volatile storage cells when power loss is detected (the *STORE* operation). On power up, data is automatically restored to the SRAM (the *RECALL* operation). Both *STORE* and *RECALL* operations are also available under software control.

The Simtek nvSRAM is the highest performance, most reliable non-volatile memory available.

BLOCK DIAGRAM

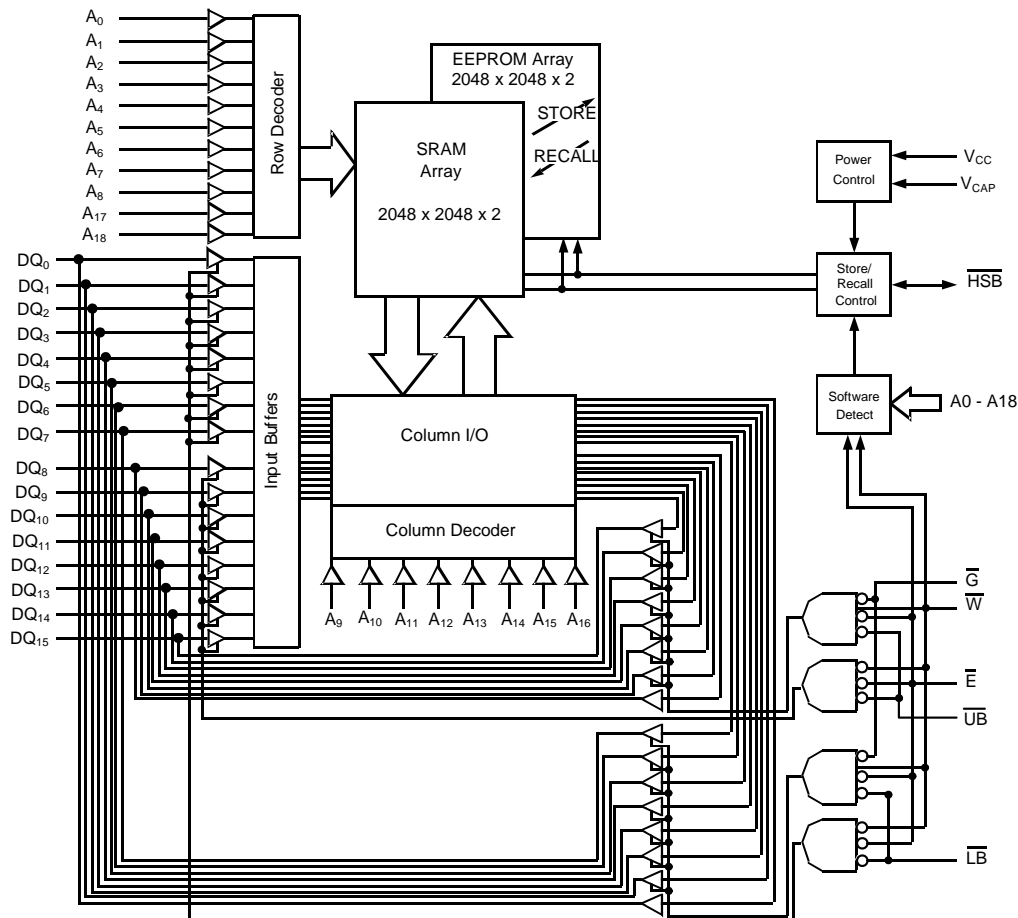

This is a product in development that has fixed target specifications that are subject to change pending characterization results.

SIMTEK Confidential & Proprietary

Truth Table for SRAM Operations

Operating Mode	\overline{E}	\overline{HSB}	\overline{W}	\overline{G}	\overline{LB}	\overline{UB}	DQ0-DQ7	DQ8-DQ15
Standby/not selected	H	H	X	X	X	X	High-Z	High-Z
Internal Read	L	H	H	H	X	X	High-Z	High-Z
	L	H	X	X	H	H	High-Z	High-Z
Lower Byte Read	L	H	H	L	L	H	Data Outputs Low-Z	High-Z
Upper Byte Read	L	H	H	L	H	L	High-Z	Data Outputs Low-Z
Word Read	L	H	H	L	L	L	Data Outputs Low-Z	Data Outputs Low-Z
Lower Byte Write	L	H	L	X	L	H	Data Inputs High-Z	High-Z
Upper Byte Write	L	H	L	X	H	L	High-Z	Data Inputs High-Z
Word Write	L	H	L	X	L	L	Data Inputs High-Z	Data Inputs High-Z

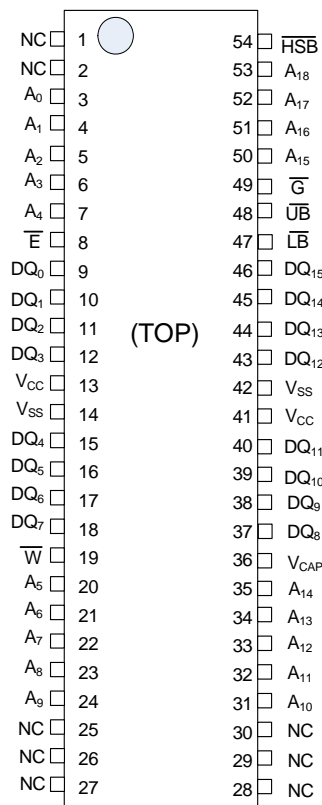

54-Pin TSOP-II

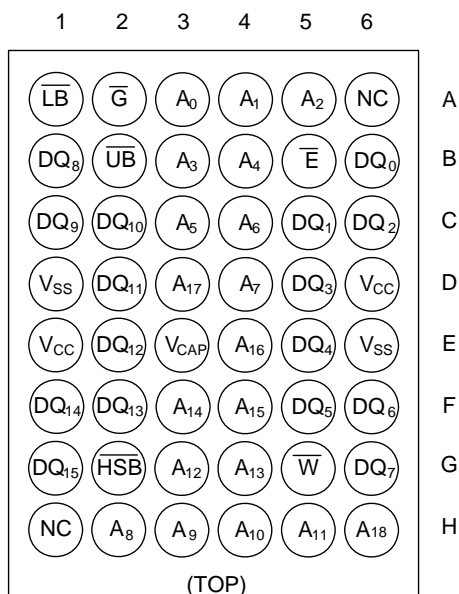

48-Ball FBGA

(See full mechanical drawings on pages 18 – 19)

PIN DESCRIPTIONS

Pin Name	I/O	Description
A ₁₈ -A ₀	Input	Address: The 19 address inputs select one of 524,288 words in the nvSRAM array
DQ ₁₅ -DQ ₀	I/O	Data: Bi-directional 16-bit data bus for accessing the nvSRAM
\bar{E}	Input	Chip Enable: The active low \bar{E} input selects the device
$\bar{L}B$	Input	Byte Write Select Input: Controls DQ7-DQ0 (unselected byte will not write or read).
$\bar{U}B$	Input	Byte Write Select Input: Controls DQ15-DQ8 (unselected byte will not write or read).
\bar{W}	Input	Write Enable: The active low \bar{W} enables data on the DQ pins to be written to the address location latched by the falling edge of \bar{E}
\bar{G}	Input	Output Enable: The active low \bar{G} input enables the data output buffers during read cycles. De-asserting \bar{G} high causes the DQ pins to tri-state.
V _{CC}	Power Supply	Power: 3.0V +20%, -10%
HSB	I/O	Hardware Store Busy: When low this output indicates a Store is in progress (also low during power up while busy). When pulled low external to the chip, it will initiate a nonvolatile STORE operation. A weak pull up resistor keeps this pin high if not connected. (Connection Optional).
V _{CAP}	Power Supply	Autostore Capacitor: Supplies power to the nvSRAM during a power loss to store data from SRAM to nonvolatile storage elements.
V _{SS}	Power Supply	Ground
NC	No Connect	This pin is not connected to the die. (Do not connect in design; reserved for future use)

ABSOLUTE MAXIMUM RATINGS^a

Voltage on Input Relative to Ground	−0.5V to 4.1V
Voltage on Input Relative to V _{SS}	−0.5V to (V _{CC} + 0.5V)
Voltage on DQ ₀₋₇ or HSB	−0.5V to (V _{CC} + 0.5V)
Temperature under Bias	−55°C to 125°C
Junction Temperature	−55°C to 140°C
Storage Temperature	−65°C to 150°C
Power Dissipation	1W
DC Output Current (1 output at a time, 1s duration)	15mA

Note a: Stresses greater than those listed under “Absolute Maximum Ratings” may cause permanent damage to the device. This is a stress rating only, and functional operation of the device at conditions above those indicated in the operational sections of this specification is not implied. Exposure to absolute maximum rating conditions for extended periods may affect reliability.

UF (TSOP-II 54) PACKAGE THERMAL CHARACTERISTICS

θ_{jc} tbd; θ_{ja} tbd [0fpm], tbd [200fpm], tbd C/W [500fpm].

BF (FBGA48) PACKAGE THERMAL CHARACTERISTICS

θ_{jc} tbd C/W; θ_{ja} tbd [0fpm], tbd [200fpm], tbd C/W [500fpm].

DC CHARACTERISTICS

(V_{CC} = 2.7V-3.6V)

SYMBOL	PARAMETER	COMMERCIAL		INDUSTRIAL		UNITS	NOTES
		MIN	MAX	MIN	MAX		
I _{CC1}	Average V _{CC} Current		65 50		70 52	mA mA	t _{AVAV} = 25ns t _{AVAV} = 45ns Dependent on output loading and cycle rate. Values obtained without output loads.
I _{CC2}	Average V _{CC} Current during STORE		12		12	mA	All Inputs Don't Care, V _{CC} = max Average current for duration of STORE cycle (t _{STORE})
I _{CC3}	Average V _{CC} Current at t _{AVAV} = 200ns 3V, 25°C, Typical		26		26	mA	$\bar{W} \geq (V_{CC} - 0.2V)$ All Other Inputs Cycling at CMOS Levels Dependent on output loading and cycle rate. Values obtained without output loads.
I _{CC4}	Average V _{CAP} Current during Auto Store Cycle		12		12	mA	All Inputs Don't Care Average current for duration of STORE cycle (t _{STORE})
I _{SB}	V _{CC} Standby Current (Standby, Stable CMOS Levels)		6		6	mA	$\bar{E} \geq (V_{CC} - 0.2V)$ All Others V _{IN} ≤ 0.2V or ≥ (V _{CC} -0.2V) Standby current level after nonvolatile cycle complete
I _{ILK}	Input Leakage Current		±2		±2	µA	V _{CC} = max V _{IN} = V _{SS} to V _{CC}
I _{OLK}	Off-State Output Leakage Current		±2		±2	µA	V _{CC} = max V _{IN} = V _{SS} to V _{CC} , \bar{E} or $\bar{G} \geq V_{IH}$
V _{IH}	Input Logic “1” Voltage	2.0	V _{CC} + 0.5	2.0	V _{CC} + 0.5	V	All Inputs
V _{IL}	Input Logic “0” Voltage	V _{SS} - 0.5	0.8	V _{SS} - 0.5	0.8	V	All Inputs
V _{OH}	Output Logic “1” Voltage	2.4		2.4		V	I _{OUT} = -2mA (except HSB)
V _{OL}	Output Logic “0” Voltage		0.4		0.4	V	I _{OUT} = 4mA
T _A	Operating Temperature	0	70	-40	85	°C	
V _{CC}	Operating Voltage	2.7	3.6	2.7	3.6	V	3.3V nominal
V _{CAP}	Storage Capacitance	135	324	135	324	µF	Between V _{CAP} pin and V _{SS} , 5V rated (Nom. 150 µF to 270 µF +20%, - 10%)
NV _C	Nonvolatile STORE operations	200		200		K	
DATA _R	Data Retention	20		20		Years	@ 55 deg C

Note: The HSB pin has I_{OUT} = -20 uA for V_{OH} of 2.4 V. This parameter is characterized but not tested.

AC TEST CONDITIONS

Input Pulse Levels	0V to 3V
Input Rise and Fall Times	≤ 5ns
Input and Output Timing Reference Levels	1.5V
Output Load	See Figure 1 and 2

CAPACITANCE^b (T_A = 25°C, f = 1.0MHz)

SYMBOL	PARAMETER	MAX	UNITS	CONDITIONS
C _{IN}	Input Capacitance	10	pF	ΔV = 0 to 3V
C _{OUT}	Output Capacitance	10	pF	ΔV = 0 to 3V

Note b: These parameters are guaranteed but not tested.

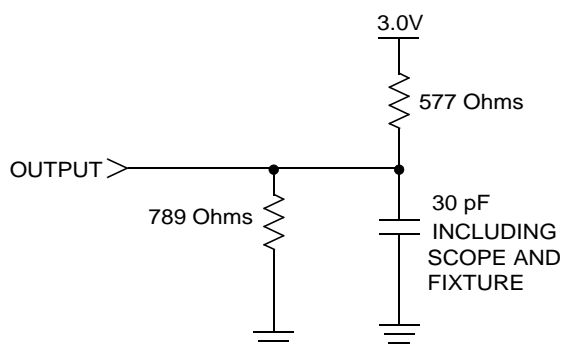

Figure 1: AC Output Loading

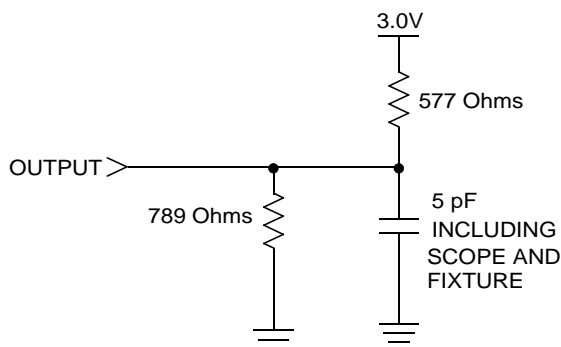

Figure 2: AC Output Loading for Tristate Specs (t_{HZ}, t_{LZ}, t_{WLQZ}, t_{WHQZ}, t_{GLQZ}, t_{GHQZ})

SRAM READ CYCLES #1 & #2

NO.	SYMBOLS			PARAMETER	STK14EE16-25		STK14EE16-45		UNITS
	#1	#2	Alt.		MIN	MAX	MIN	MAX	
1	t_{ELQV}	t_{ELQV}	t_{ACS}	Chip Enable Access Time		25		45	ns
2	t_{AVAV}^c	t_{ELEH}^c	t_{RC}	Read Cycle Time	25		45		ns
3	t_{AVQV}^d	t_{AVQV}^d	t_{AA}	Address Access Time		25		45	ns
4	t_{GLQV}	t_{GLQV}	t_{OE}	Output Enable to Data Valid		12		20	ns
6	t_{AXQX}^d	t_{AXQX}^d	t_{OH}	Output Hold after Address Change	3		3		ns
6	t_{ELQX}	t_{ELQX}	t_{LZ}	Address Change or Chip Enable to Output Active	3		3		ns
7	t_{EHQZ}^e	t_{EHQZ}^e	t_{HZ}	Address Change or Chip Disable to Output Inactive		10		15	ns
8	t_{GLQX}	t_{GLQX}	t_{OLZ}	Output Enable to Output Active	0		0		ns
9	t_{GHQZ}^e	t_{GHQZ}^e	t_{OHZ}	Output Disable to Output Inactive		10		15	ns
10	t_{ELICCH}^b	t_{ELICCH}^b	t_{PA}	Chip Enable to Power Active	0		0		ns
11	t_{EHICCL}^b	t_{EHICCL}^b	t_{PS}	Chip Disable to Power Standby		25		45	ns
29	t_{EHAX}			Address Hold after End of Read	0		0		ns

Note c: \overline{W} must be high during SRAM READ cycles.

Note d: Device is continuously selected with \overline{E} and \overline{G} both low, \overline{LB} and \overline{UB} select bytes read.

Note e: Measured $\pm 200mV$ from steady state output voltage.

Note f: HSB must remain high during READ and WRITE cycles.

SRAM READ CYCLE #1: Address Controlled^{c,d,f}

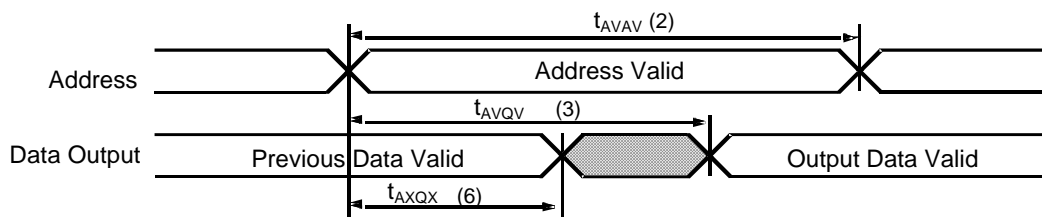

SRAM READ CYCLE #2: \overline{E} and \overline{G} Controlled^{c,f}

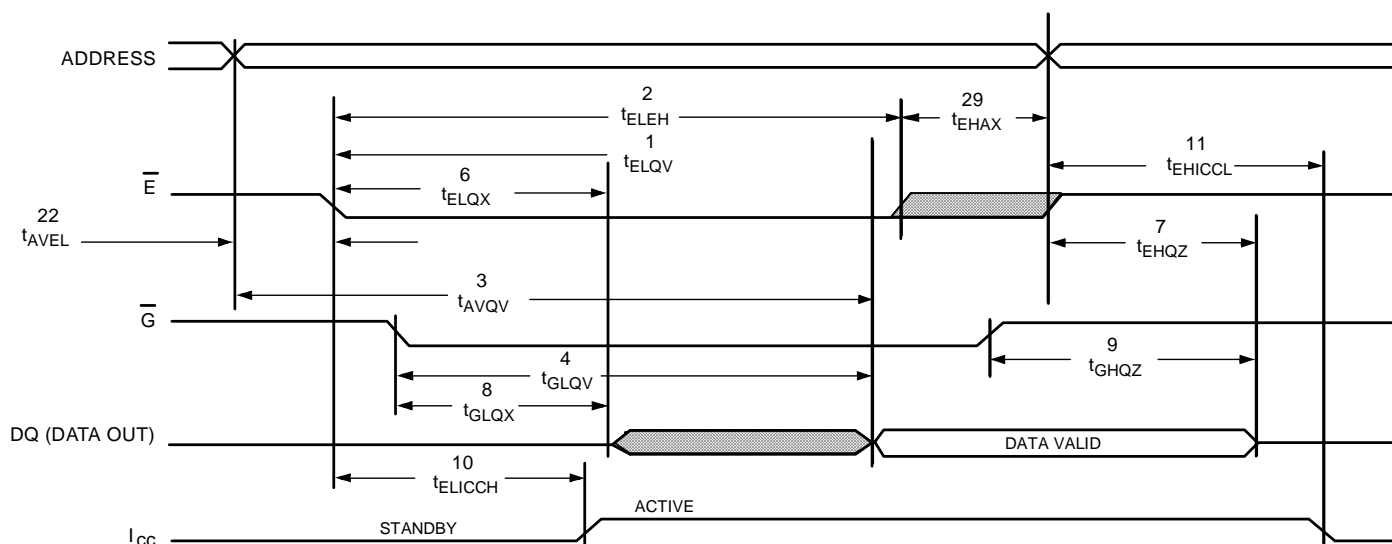

SRAM WRITE CYCLES #1, #2, and #3

NO.	SYMBOLS				PARAMETER	STK14EE16-25		STK14EE16-45		UNITS
	#1	#2	#3	Alt.		MIN	MAX	MIN	MAX	
15	t_{AVAV}	t_{AVAV}	t_{AVAV}	t_{WC}	Write Cycle Time	25		45		ns
16	t_{WLWH}	t_{WLEH}	t_{WLBH}	t_{WP}	Write Pulse Width	20		30		ns
17	t_{ELWH}	t_{ELEH}	t_{ELBH}	t_{CW}	Chip Enable to End of Write	20		30		ns
18	t_{BLWH}	t_{BLEH}	t_{BLBH}		Byte Enable to End of Write	20		30		ns
19	t_{DVWH}	t_{DVEH}	t_{DVBH}	t_{DW}	Data Set-up to End of Write	10		15		ns
20	t_{WHDX}	t_{EHDX}	t_{BHDX}	t_{DH}	Data Hold after End of Write	0		0		ns
21	t_{AVWH}	t_{AVEH}	t_{AVBH}	t_{AW}	Address Set-up to End of Write	20		30		ns
22	t_{AVWL}	t_{AVEL}	t_{AVBL}	t_{AS}	Address Set-up to Start of Write	0		0		ns
23	t_{WHAX}	t_{EHAX}	t_{BHAX}	t_{WR}	Address Hold after End of Write	0		0		ns
24	$t_{WLQZ}^{e,g}$			t_{WZ}	Write Enable to Output Disable		10		15	ns
25	t_{WHQX}			t_{OW}	Output Active after End of Write	3		3		ns

Note g: If \bar{W} is low when \bar{E} goes low, the outputs remain in the high-impedance state.

Note h: \bar{E} or \bar{W} must be $\geq V_{IH}$ during address transitions.

SRAM WRITE CYCLE #1: \bar{W} Controlled^{g,h}

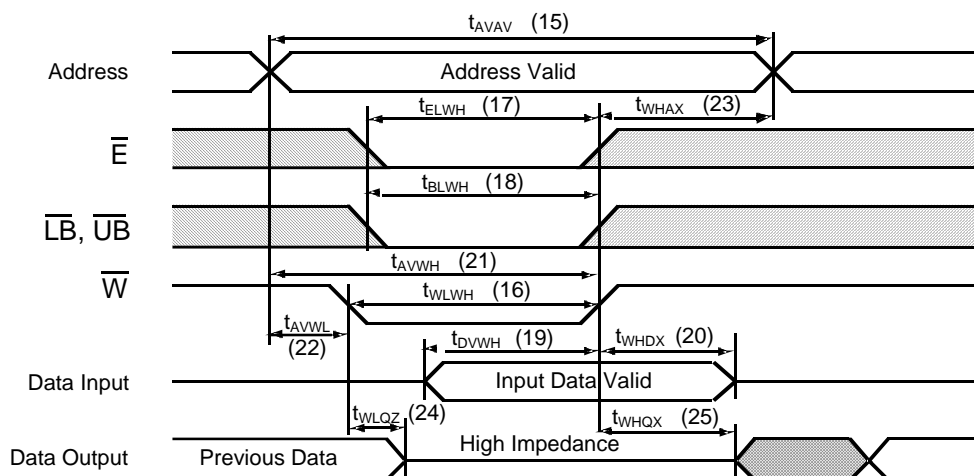

SRAM WRITE CYCLE #2: \bar{E} Controlled^{g,h}

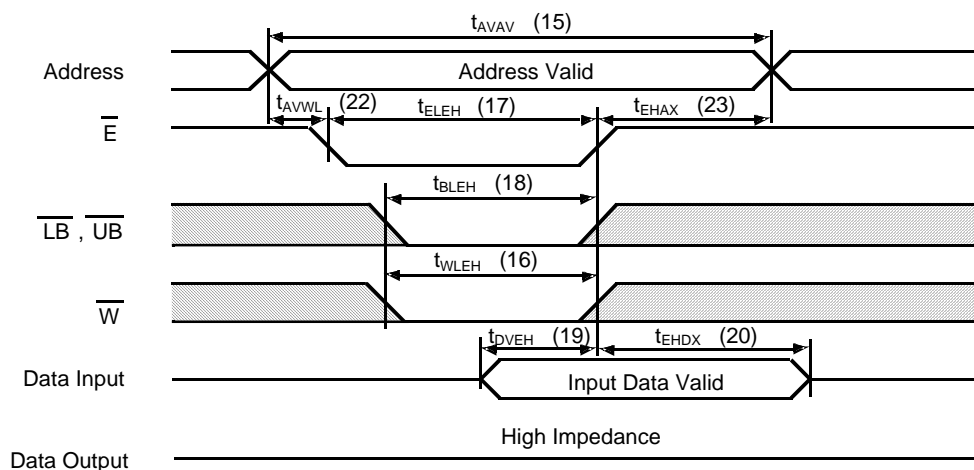

SRAM WRITE CYCLE #3: \overline{LB} , \overline{UB} Controlled^{g,h}

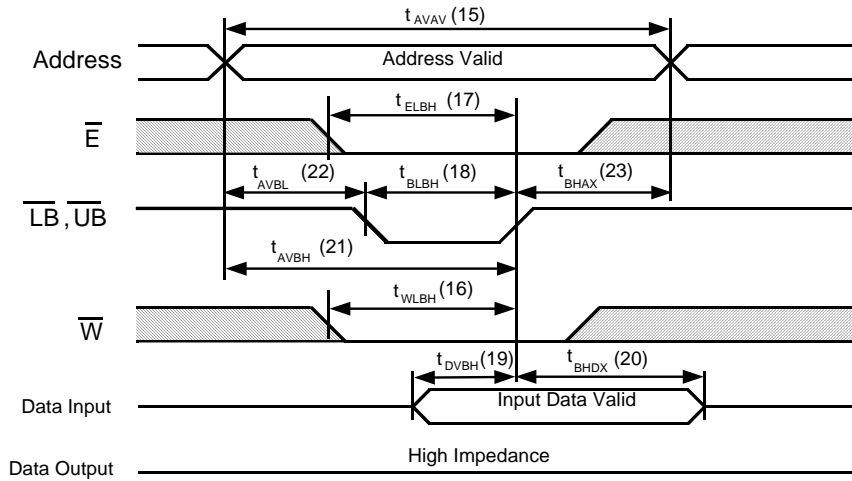

AutoStore™/POWER-UP RECALL

NO.	SYMBOLS		PARAMETER	STK14EE16		UNITS	NOTES
	Standard	Alternate		MIN	MAX		
26	$t_{HRECALL}$		Power-up <i>RECALL</i> Duration		20	ms	i
27	t_{STORE}	t_{HLHZ}	<i>STORE</i> Cycle Duration		12.5	ms	j
28	V_{SWITCH}		Low Voltage Trigger Level		2.65	V	
29	V_{CCRISE}		V_{CC} Rise Time	150		μ s	

Note i: $t_{HRECALL}$ starts from the time V_{CC} rises above V_{SWITCH}

Note j: If an SRAM WRITE has not taken place since the last nonvolatile cycle, no *STORE* will take place

AutoStore™/POWER-UP RECALL

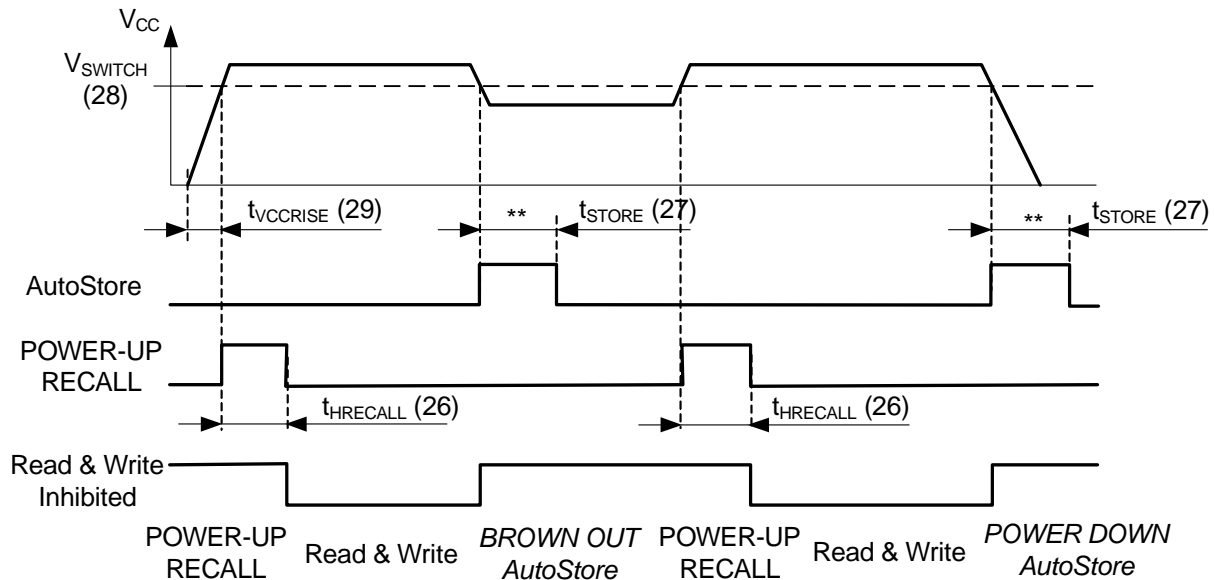

** AutoStore occurs only if at least one SRAM Write has happened

Note: Read and Write cycles will be ignored during STORE, RECALL and while V_{CC} is below V_{SWITCH}

SOFTWARE-CONTROLLED STORE/RECALL CYCLE^{k,l}

NO.	Symbols			PARAMETER	STK14EE16-25		STK14EE16-45		UNITS	NOTES
	\bar{E} Cont ^k	\bar{G} Cont ^k	Alternate		MIN	MAX	MIN	MAX		
30	t_{AVAV}	t_{AVAV}	t_{RC}	STORE/RECALL Initiation Cycle Time	25		45		ns	
31	t_{AVEL}	t_{AVGL}	t_{AS}	Address Set-up Time	0		0		ns	
32	t_{ELEH}	t_{GLGH}	t_{CW}	Clock Pulse Width	20		30		ns	
33	t_{EHAX}	t_{GHAX}		Address Hold Time	1		1		ns	l
34	t_{RECALL}	t_{RECALL}		RECALL Duration		150		150	μ s	

Note k: The software sequence is clocked on the falling edge of \bar{E} controlled READS or \bar{G} controlled READS

Note l: The six consecutive addresses must be read in the order listed in the Software STORE/RECALL Mode Selection Table. \bar{W} must be high during all six consecutive \bar{E} or \bar{G} controlled cycles.

SOFTWARE STORE/RECALL CYCLE: \bar{E} CONTROLLED^l

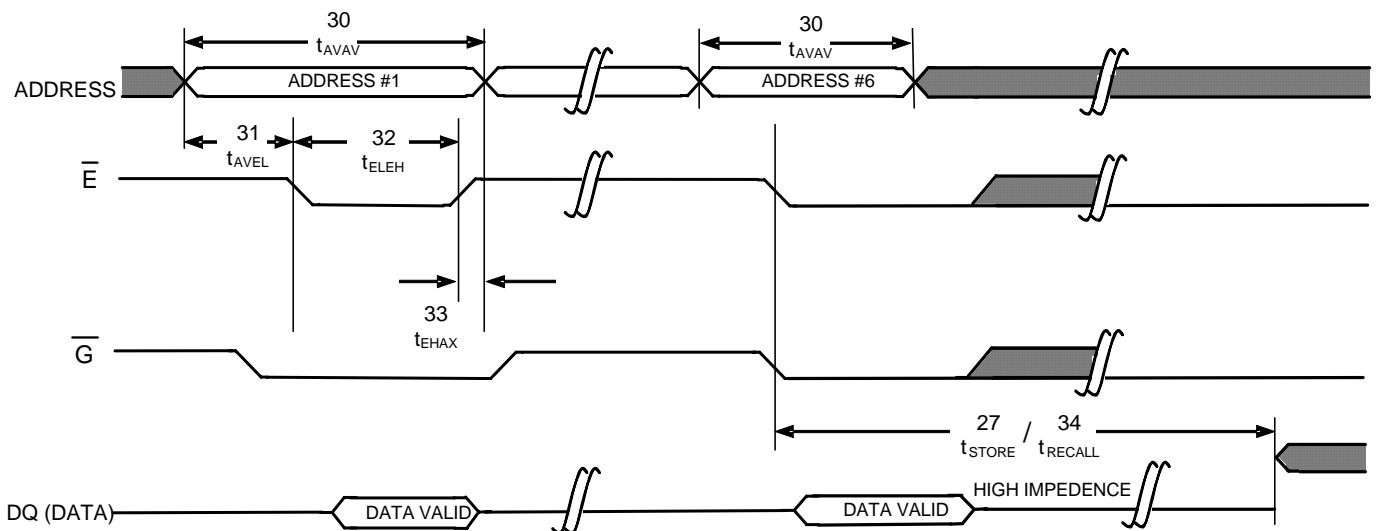

SOFTWARE STORE/RECALL CYCLE: \bar{G} CONTROLLED^l

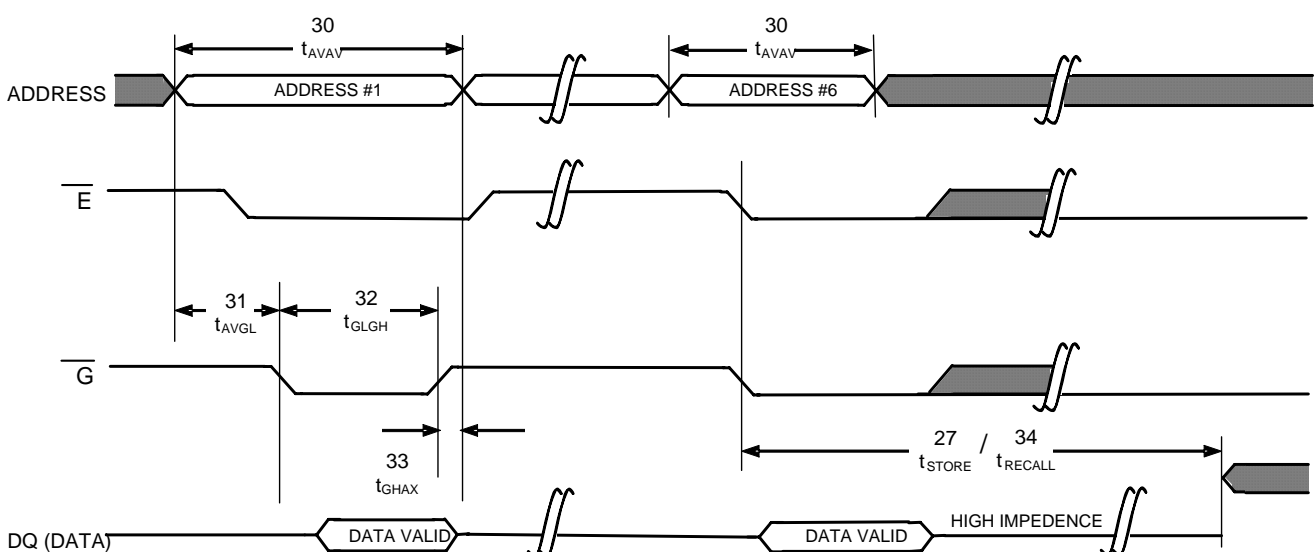

HARDWARE STORE CYCLE

	SYMBOLS		PARAMETER	STK14EE16		UNITS	NOTES
	Standard	Alternate		MIN	MAX		
35	t_{DELAY}	t_{HLQZ}	Hardware STORE to SRAM Disabled	1	70	μs	m
36	t_{HLHX}		Hardware STORE Pulse Width	15		ns	

Note m: On a hardware STORE initiation, SRAM operation continues to be enabled for time t_{DELAY} to allow read/write cycles to complete

HARDWARE STORE CYCLE

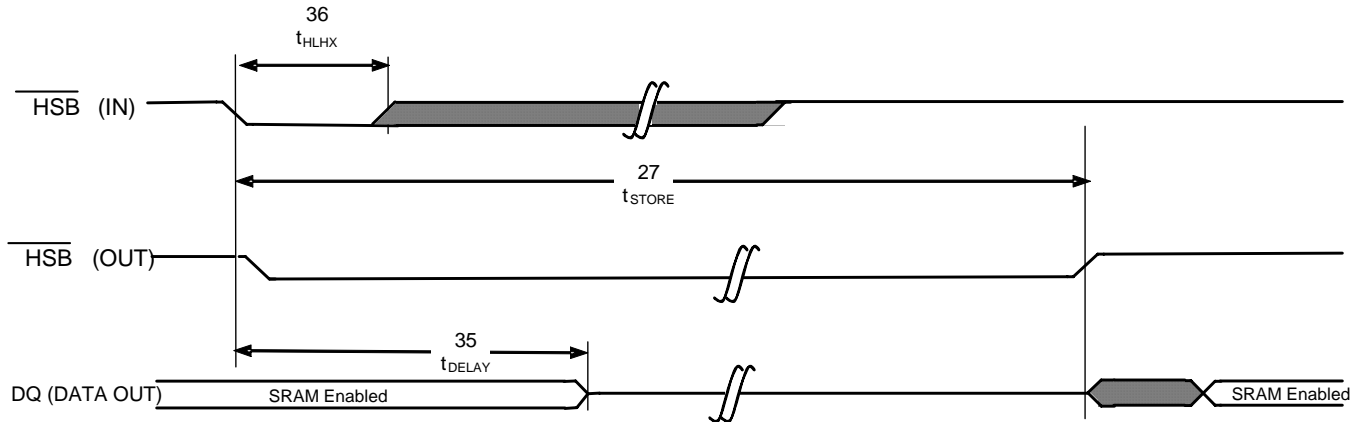

Soft Sequence Commands

NO.	SYMBOLS	PARAMETER	STK14EE16		UNITS	NOTES
	Standard		MIN	MAX		
33	t_{SS}	Soft Sequence Processing Time		70	μs	n,o

Note n: This is the amount of time that it takes to take action on a soft sequence command. Vcc power must remain high to effectively register command.

Note o: Commands like Store and Recall lock out I/O until operation is complete which further increases this time. See specific command.

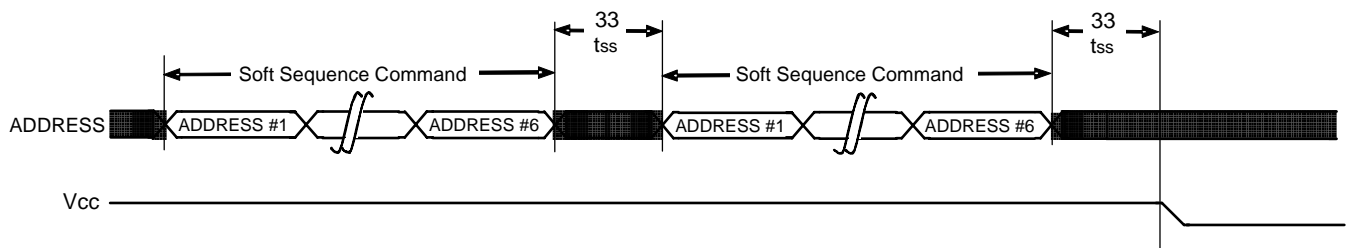

MODE SELECTION

\bar{E}	\bar{W}	$\bar{G}, \bar{UB}, \bar{LB}$	A ₁₈ -A ₀	Mode	I/O	Power	Notes
H	X	X	X	Not Selected	Output High Z	Standby	
L	H	L	X	Read SRAM	Output Data	Active	
L	L	X	X	Write SRAM	Input Data	Active	
L	H	L	0x04E38 0x0B1C7 0x083E0 0x07C1F 0x0703F 0x08B45	Read SRAM Read SRAM Read SRAM Read SRAM Read SRAM AutoStore Disable	Output Data Output Data Output Data Output Data Output Data Output Data	Active	p,q,r
L	H	L	0x04E38 0x0B1C7 0x083E0 0x07C1F 0x0703F 0x04B46	Read SRAM Read SRAM Read SRAM Read SRAM Read SRAM AutoStore Enable	Output Data Output Data Output Data Output Data Output Data Output Data	Active	p,q,r
L	H	L	0x04E38 0x0B1C7 0x083E0 0x07C1F 0x0703F 0x08FC0	Read SRAM Read SRAM Read SRAM Read SRAM Read SRAM Nonvolatile Store	Output Data Output Data Output Data Output Data Output Data Output High Z	Active I _{CC2}	p,q,r
L	H	L	0x04E38 0x0B1C7 0x083E0 0x07C1F 0x0703F 0x04C63	Read SRAM Read SRAM Read SRAM Read SRAM Read SRAM Nonvolatile Recall	Output Data Output Data Output Data Output Data Output Data Output High Z	Active	p,q,r

Note p: The six consecutive addresses must be in the order listed. \bar{W} must be high during all six consecutive cycles to enable a nonvolatile cycle.

Note q: While there are 19 address lines on the STK14EE16, only the lower 16 are used to control software modes

Note r: I/O state depends on the state of \bar{G} , \bar{UB} , and \bar{LB} . The I/O table shown assumes \bar{G} , \bar{UB} , and \bar{LB} low.

nvSRAM OPERATION

nvSRAM

The STK14EE16 nvSRAM is made up of two functional components paired in the same physical cell. These are the SRAM memory cell and a nonvolatile QuantumTrap cell. The SRAM memory cell operates like a standard fast static RAM. Data in the SRAM can be transferred to the nonvolatile cell (the STORE operation), or from the nonvolatile cell to SRAM (the RECALL operation). This unique architecture allows all cells to be stored and recalled in parallel. During the STORE and RECALL operations SRAM READ and WRITE operations are inhibited. The STK14EE16 supports unlimited read and writes like a typical SRAM. In addition, it provides unlimited RECALL operations from the nonvolatile cells and up to 1 million STORE operations.

SRAM READ

The STK14EE16 performs a READ cycle whenever \overline{E} and \overline{G} are low while \overline{W} and \overline{HSB} are high. The address specified on pins A_{0-18} determine which of the 524,288 data words will be accessed. Byte enables (\overline{UB} , \overline{LB}) determine which bytes are enabled to the output. When the READ is initiated by an address transition, the outputs will be valid after a delay of t_{AVQV} (READ cycle #1). If the READ is initiated by \overline{E} and \overline{G} , the outputs will be valid at t_{ELQV} or at t_{GLQV} , whichever is later (READ cycle #2). The data outputs will repeatedly respond to address changes within the t_{AVQV} access time without the need for transitions on any control input pins, and will remain valid until another address change or until \overline{E} or \overline{G} is brought high, or \overline{W} and \overline{HSB} is brought low.

SRAM WRITE

A WRITE cycle is performed whenever \overline{E} and \overline{W} are low and \overline{HSB} is high. The address inputs must be stable prior to entering the WRITE cycle and must remain stable until either \overline{E} or \overline{W} goes high at the end of the cycle. The data on the common I/O pins DQ_{0-15} will be written into memory if it is valid t_{DVWH} before the end of a \overline{W} controlled WRITE or t_{DVEH} before the end of an \overline{E} controlled WRITE. The Byte Enable inputs (\overline{UB} , \overline{LB}) determine which bytes are written.

It is recommended that \overline{G} be kept high during the entire WRITE cycle to avoid data bus contention on common I/O lines. If \overline{G} is left low, internal circuitry will turn off the output buffers t_{WLQZ} after \overline{W} goes low.

AutoStore OPERATION

The STK14EE16 stores data to nvSRAM using one of three storage operations. These three operations are Hardware Store (activated by \overline{HSB}), Software Store (activated by an address sequence), and AutoStore (on power down).

AutoStore operation is a unique feature of Simtek Quantum Trap technology that is enabled by default on the STK14EE16.

During normal operation, the device will draw current from V_{CC} to charge a capacitor connected to the V_{CAP} pin. This stored charge will be used by the chip to perform a single STORE operation. If the voltage on the V_{CC} pin drops below V_{SWITCH} , the part will automatically disconnect the V_{CAP} pin from V_{CC} . A STORE operation will be initiated with power provided by the V_{CAP} capacitor.

Figure 3 shows the proper connection of the storage capacitor (V_{CAP}) for automatic store operation. Refer to the DC CHARACTERISTICS table for the size of the capacitor. The voltage on the V_{CAP} pin is driven to 3.6V by a regulator on the chip. A pull up should be placed on \overline{W} to hold it inactive during power up. This pull-up is only effective if the \overline{W} signal

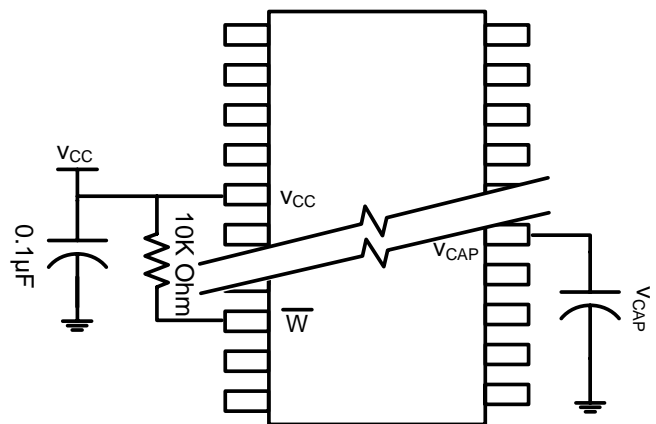

Figure 3. AutoStore Mode

is tri-state during power up. Many MPU's will tri-state their controls on power up. This should be verified when using the pullup. When the nvSRAM comes out on power-on-recall, the MPU must be active or the \overline{W} held inactive until the MPU comes out of reset.

To reduce unneeded nonvolatile stores, AutoStore and Hardware Store operations will be ignored unless at least one WRITE operation has taken place since the most recent STORE or RECALL cycle. Software initiated STORE cycles are performed regardless of whether a WRITE operation has taken place. The \overline{HSB} signal can be monitored by the system to detect an AutoStore cycle is in progress.

HARDWARE STORE (\overline{HSB}) OPERATION

The STK14EE16 provides the \overline{HSB} pin for controlling and acknowledging the STORE operations. The \overline{HSB} pin can be used to request a hardware STORE cycle. When the \overline{HSB} pin is driven low, the STK14EE16 will conditionally initiate a STORE operation after t_{DELAY} . An actual STORE cycle will only begin if a WRITE to the SRAM took place since the last STORE or RECALL cycle. The \overline{HSB} pin has a very resistive pullup and is internally driven low to indicate a busy condition while the STORE (initiated by any means) is in progress. This pin should be externally pulled up if it is used to drive other inputs.

SRAM READ and WRITE operations that are in progress when \overline{HSB} is driven low by any means are given time to complete before the STORE operation is initiated. After \overline{HSB} goes low, the STK14EE16 will continue to allow SRAM operations for t_{DELAY} . During t_{DELAY} , multiple SRAM READ operations may take place. If a WRITE is in progress when \overline{HSB} is pulled low, it will be allowed a time, t_{DELAY} , to complete. However, any SRAM WRITE cycles requested after \overline{HSB} goes low will be inhibited until \overline{HSB} returns high.

If \overline{HSB} is not used, it should be left unconnected.

HARDWARE RECALL (POWER-UP)

During power up or after any low-power condition ($V_{CC} < V_{SWITCH}$), an internal RECALL request will be latched. When V_{CC} once again exceeds the sense voltage of V_{SWITCH} , a RECALL cycle will automatically be initiated and will take $t_{HRECALL}$ to complete.

SOFTWARE STORE

Data can be transferred from the SRAM to the non-volatile memory by a software address sequence. The STK14EE16 software STORE cycle is initiated by executing sequential \overline{E} controlled or \overline{G} controlled READ cycles from six specific address locations in exact order. During the STORE cycle, previous data is erased and then the new data is programmed into the nonvolatile elements. Once a STORE cycle is initiated, further memory inputs and outputs are disabled until the cycle is completed.

To initiate the software STORE cycle, the following READ sequence must be performed:

1	Read Address	0x04E38	Valid READ
2	Read Address	0x0B1C7	Valid READ
3	Read Address	0x083E0	Valid READ
4	Read Address	0x07C1F	Valid READ
5	Read Address	0x0703F	Valid READ
6	Read Address	0x08FC0	Initiate STORE Cycle

Once the sixth address in the sequence has been entered, the STORE cycle will commence and the chip will be disabled. It is important that READ cycles and not WRITE cycles be used in the sequence and that \overline{G} , \overline{UB} , and \overline{LB} are active. After the t_{STORE} cycle time has been fulfilled, the SRAM will again be activated for READ and WRITE operation.

SOFTWARE RECALL

Data can be transferred from the nonvolatile memory to the SRAM by a software address sequence. A software RECALL cycle is initiated with a sequence of READ operations in a manner similar to the software STORE initiation. To initiate the RECALL cycle, the following sequence of \overline{E} controlled or \overline{G} controlled READ operations must be performed:

1	Read Address	0x04E38	Valid READ
2	Read Address	0x0B1C7	Valid READ
3	Read Address	0x083E0	Valid READ
4	Read Address	0x07C1F	Valid READ
5	Read Address	0x0703F	Valid READ
6	Read Address	0x04C63	Initiate RECALL Cycle

Internally, RECALL is a two-step procedure. First, the SRAM data is cleared, and second, the nonvola-

tile information is transferred into the SRAM cells. After the t_{RECALL} cycle time, the SRAM will once again be ready for READ or WRITE operations. The RECALL operation in no way alters the data in the nonvolatile storage elements. Care must be taken so the controlling falling edge is glitch and ring free so as not to double clock the read address.

DATA PROTECTION

The STK14EE16 protects data from corruption during low-voltage conditions by inhibiting all externally initiated STORE and WRITE operations. The low-voltage condition is detected when $V_{\text{CC}} < V_{\text{SWITCH}}$.

If the STK14EE16 is in a WRITE mode (both \bar{E} and \bar{W} low) at power-up, after a RECALL, or after a STORE, the WRITE will be inhibited until a negative transition on \bar{E} or \bar{W} is detected. This protects against inadvertent writes during power up or brown out conditions.

NOISE CONSIDERATIONS

The STK14EE16 is a high-speed memory and so must have a high-frequency bypass capacitor of 0.1 μF connected between both V_{CC} pins and V_{SS} ground plane with no plane break to chip V_{SS} . Use leads and traces that are as short as possible. As with all high-speed CMOS ICs, careful routing of power, ground, and signals will reduce circuit noise.

BEST PRACTICES

nvSRAM products have been used effectively for over 15 years. While ease-of-use is one of the product's main system values, experience gained working with hundreds of applications has resulted in the following suggestions as best practices:

- The non-volatile cells in this nvSRAM product are delivered from Simtek with 0x00 written in all cells. Incoming inspection routines at customer or contract manufacturer's sites will sometimes reprogram these values. Final NV patterns are typically repeating patterns of AA, 55, 00, FF, A8, or 5A. End product's firmware should not assume an NV array is in a set programmed state. Routines that check memory content values to determine first time system configuration, cold or warm boot status, etc. should always program a unique NV pattern (i.e., repeating 4-byte pattern of 46 E6 49 53 hex) as part of the final system manufactur-

ing test to ensure these system routines work consistently.

- Power up boot firmware routines should rewrite the nvSRAM into the desired state (autostore enabled, etc.). While the nvSRAM is shipped in a preset state, best practice is to again rewrite the nvSRAM into the desired state as a safeguard against events that might flip the bit inadvertently (program bugs, incoming inspection routines, etc.).
- The autostore enabled/disabled feature will reset to "autostore enabled" on every power down event captured by the nvSRAM. The application firmware should disable autostore on each reset sequence that this behavior is desired.
- The V_{cap} value specified in this datasheet includes a minimum and a maximum value size. Best practice is to meet this requirement and not exceed the max V_{cap} value because the nvSRAM internal algorithm calculates V_{cap} charge time based on this max V_{cap} value. Customers that want to use a larger V_{cap} value to make sure there is extra store charge and store time should discuss their V_{cap} size selection with Simtek to understand any impact on the V_{cap} voltage level at the end of a t_{RECALL} period.

LOW AVERAGE ACTIVE POWER

CMOS technology provides the STK14EE16 with the benefit of power supply current that scales with cycle time. Less current will be drawn as the memory cycle time becomes longer than 50 ns. Figure 4 shows the relationship between I_{CC} and READ/WRITE cycle time. Worst-case current consumption is shown for commercial temperature range, $V_{\text{CC}}=3.6\text{V}$, and chip enable at maximum frequency. Only standby current is drawn when the chip is disabled. The overall average current drawn by the STK14EE16 depends on the following items:

- 1 The duty cycle of chip enable
- 2 The overall cycle rate for operations
- 3 The ratio of READs to WRITEs
- 4 The operating temperature
- 5 The V_{CC} Level
- 6 I/O Loading

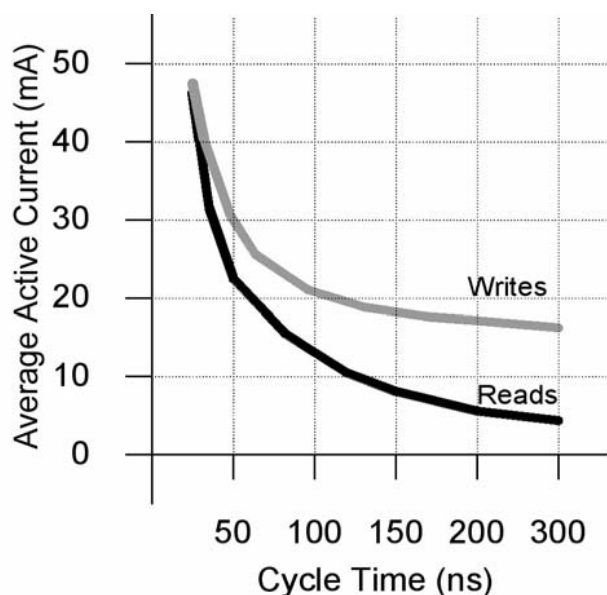

Figure 4 - Current vs Cycle Time

PREVENTING AUTOSTORE

The AutoStore function can be disabled by initiating an *AutoStore Disable* sequence. A sequence of READ operations is performed in a manner similar to the software STORE initiation. To initiate the *AutoStore Disable* sequence, the following sequence of \bar{E} controlled or \bar{G} controlled READ operations must be performed:

1	Read Address	0x04E38	Valid READ
2	Read Address	0x0B1C7	Valid READ
3	Read Address	0x083E0	Valid READ
4	Read Address	0x07C1F	Valid READ
5	Read Address	0x0703F	Valid READ
6	Read Address	0x08B45	AutoStore Disable

The AutoStore can be re-enabled by initiating an *AutoStore Enable* sequence. A sequence of READ operations is performed in a manner similar to the software RECALL initiation. To initiate the *AutoStore Enable* sequence, the following sequence of \bar{E} controlled or \bar{G} controlled READ operations must be performed:

1	Read Address	0x04E38	Valid READ
2	Read Address	0x0B1C7	Valid READ
3	Read Address	0x083E0	Valid READ
4	Read Address	0x07C1F	Valid READ
5	Read Address	0x0703F	Valid READ
6	Read Address	0x04B46	AutoStore Enable

If the AutoStore function is disabled or re-enabled, a manual STORE operation (Hardware or Software) needs to be issued to save the AutoStore state through subsequent power down cycles. The part comes from the factory with AutoStore enabled, but best design practice is to set the enable or disable state during each power-up sequence and not depend on this factory default condition. Simtek recommends users configure the part completely for the specific application.

ORDERING INFORMATION

STK14EE16-U F 45 I TR

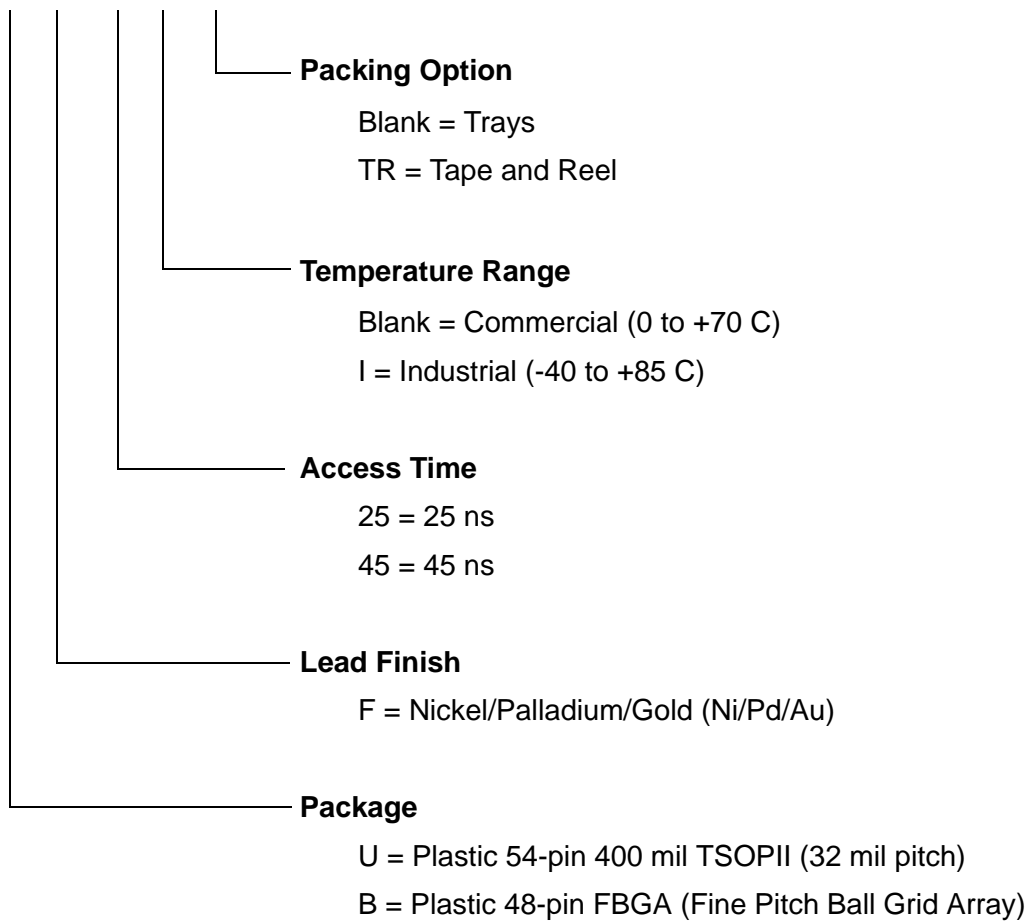

Ordering Codes

Part Number	Description	Access Times	Temperature
STK14EE16-UF25	3V 512Kx16 AutoStore nvSRAM TSOP54-400	25 ns access time	Commercial
STK14EE16-UF25TR	3V 512Kx16 AutoStore nvSRAM TSOP54-400	25 ns access time	Commercial
STK14EE16-UF45	3V 512Kx16 AutoStore nvSRAM TSOP54-400	45 ns access time	Commercial
STK14EE16-UF45TR	3V 512Kx16 AutoStore nvSRAM TSOP54-400	45 ns access time	Commercial
STK14EE16-BF25	3V 512Kx16 AutoStore nvSRAM FBGA48	25 ns access time	Commercial
STK14EE16-BF25TR	3V 512Kx16 AutoStore nvSRAM FBGA48	25 ns access time	Commercial
STK14EE16-BF45	3V 512Kx16 AutoStore nvSRAM FBGA48	45 ns access time	Commercial
STK14EE16-BF45TR	3V 512Kx16 AutoStore nvSRAM FBGA48	45 ns access time	Commercial
STK14EE16-UF25I	3V 512Kx16 AutoStore nvSRAM TSOP54-400	25 ns access time	Industrial
STK14EE16-UF25ITR	3V 512Kx16 AutoStore nvSRAM TSOP54-400	25 ns access time	Industrial
STK14EE16-UF45I	3V 512Kx16 AutoStore nvSRAM TSOP54-400	45 ns access time	Industrial
STK14EE16-UF45ITR	3V 512Kx16 AutoStore nvSRAM TSOP54-400	45 ns access time	Industrial
STK14EE16-BF25I	3V 512Kx16 AutoStore nvSRAM FBGA48	25 ns access time	Industrial
STK14EE16-BF25ITR	3V 512Kx16 AutoStore nvSRAM FBGA48	25 ns access time	Industrial
STK14EE16-BF45I	3V 512Kx16 AutoStore nvSRAM FBGA48	45 ns access time	Industrial
STK14EE16-BF45ITR	3V 512Kx16 AutoStore nvSRAM FBGA48	45 ns access time	Industrial

PACKAGE DIAGRAMS

54-Pin TSOPII

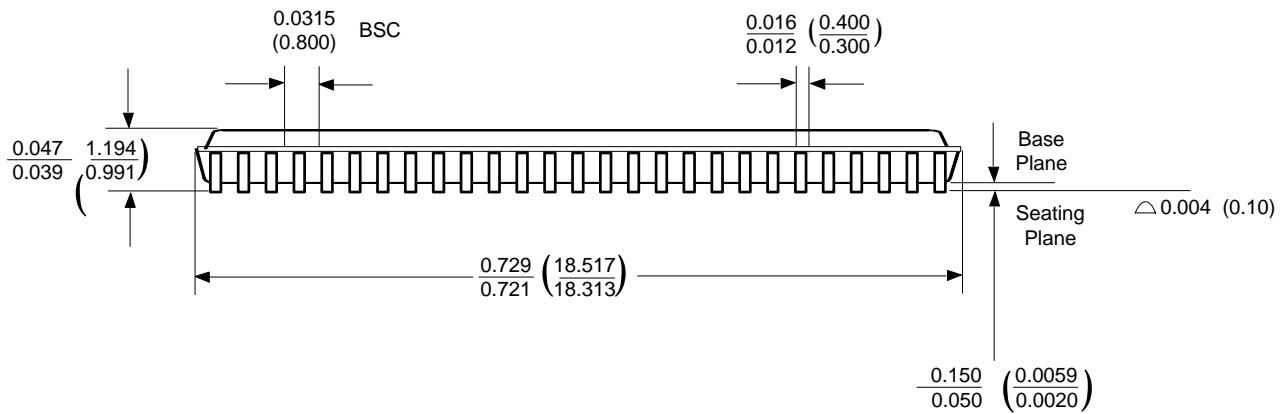
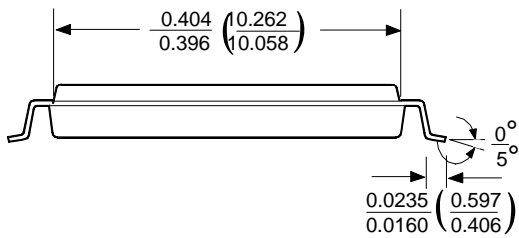
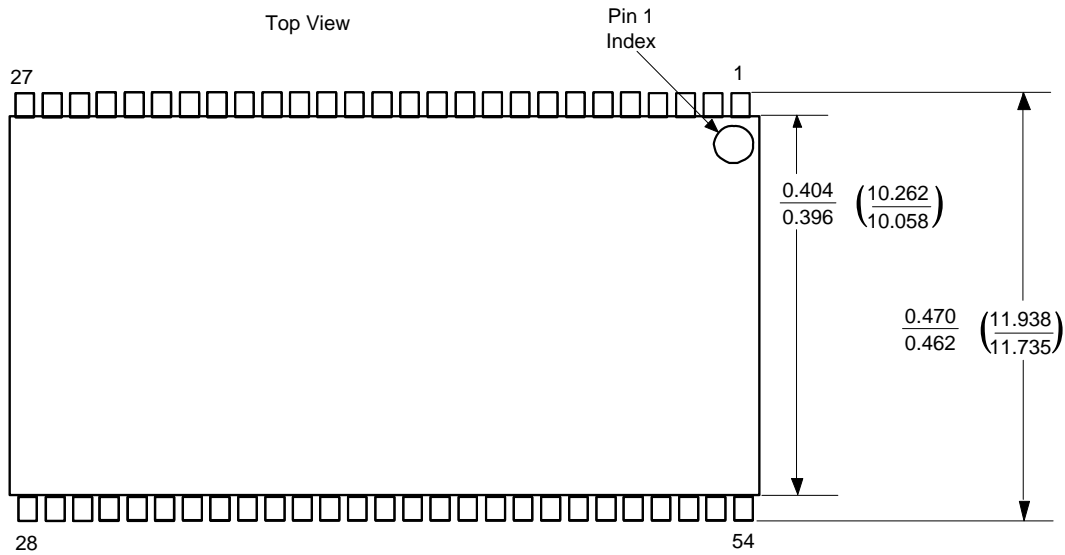

DIM = INCHES MAX
MIN

DIM = mm (MAX)
MIN

48-Ball FBGA

TOP VIEW

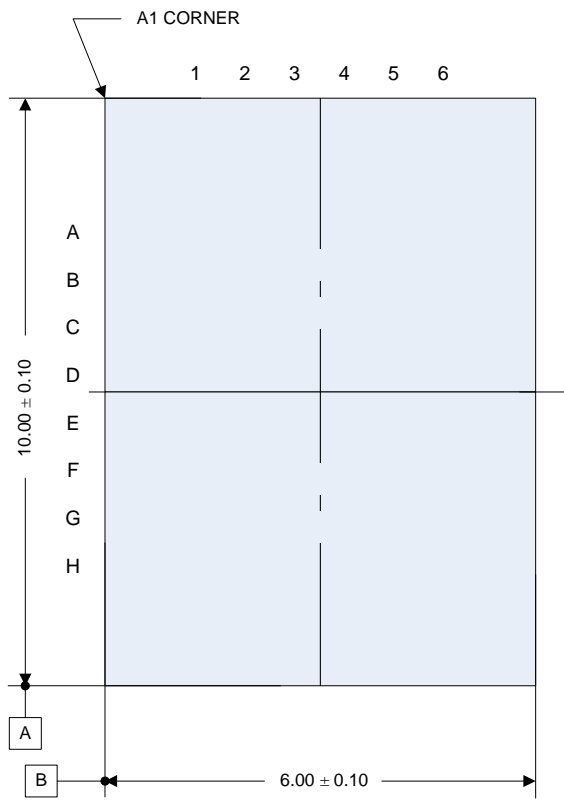

BOTTOM VIEW

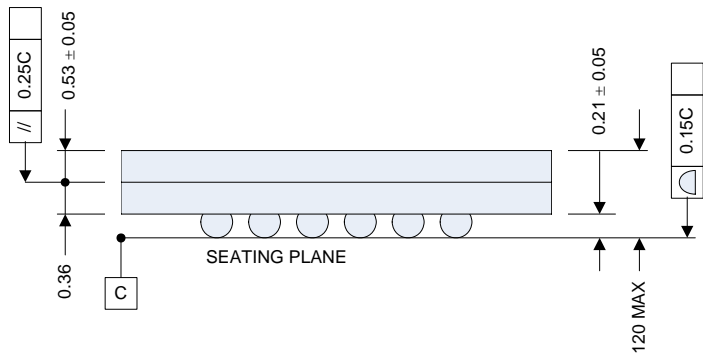
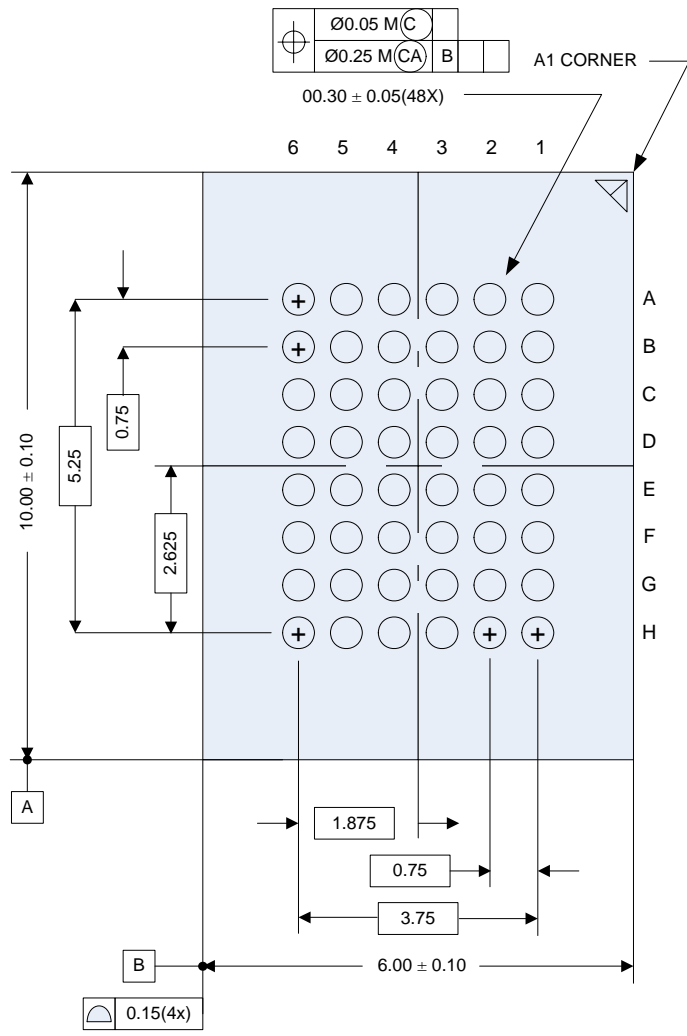

Document Revision History

Rev	Date	Change
1.0	March 2008	Preliminary

SIMTEK STK14EE16 Datasheet, March 2008

Copyright 2008, Simtek Corporation. All rights reserved.

This datasheet may only be printed for the expressed use of Simtek Customers. No part of the datasheet may be reproduced in any other form or means without the express written permission from Simtek Corporation. The information contained in this publication is believed to be accurate, but changes may be made without notice. Simtek does not assume responsibility for, or grant or imply any warranty, including MERCHANTABILITY or FITNESS FOR A PARTICULAR PURPOSE regarding this information, the product or its use. Simtek products are not warranted nor intended to be used for medical, life support, life saving, critical control or safety applications, unless pursuant to an express written agreement with Simtek. Furthermore, Simtek does not authorize its products for use as critical components in life-support systems where a malfunction or failure may reasonably be expected to result in significant injury to the user. The inclusion of Simtek products in life-support systems application implies that the manufacturer assumes all risk of such use and in doing so indemnifies Simtek against all charges. Nothing herein constitutes a license, grant or transfer of any rights to any Simtek patent, copyright, trademark, or other proprietary right.