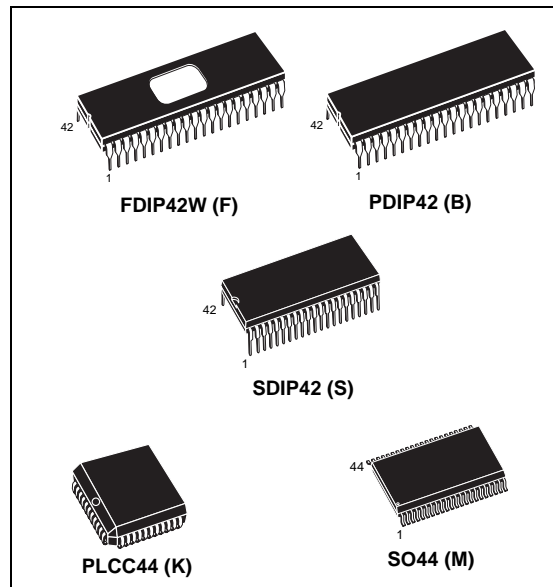


## 16 Mbit (2 Mb x 8 or 1 Mb x 16) UV EPROM and OTP EPROM

### Features

- 5V  $\pm$  10% Supply Voltage in Read Operation
- Access Time: 50 ns
- Byte-wide or Word-wide Configurable
- 16 Mbit Mask ROM Replacement
- Low Power Consumption
  - Active Current: 70 mA at 8 MHz
  - Standby Current: 100  $\mu$ A
- Programming Voltage: 12.5V  $\pm$  0.25V
- Programming Time: 50  $\mu$ s/word
- Electronic Signature
  - Manufacturer Code: 20h
  - Device Code: B1h
- ECOPACK® packages available



# Contents

<b>1</b>	<b>Summary description</b> .....	<b>5</b>
<b>2</b>	<b>Device description</b> .....	<b>8</b>
2.1	Read mode .....	8
2.2	Standby mode .....	8
2.3	Two-line output control .....	9
2.4	System considerations .....	9
2.5	Programming .....	9
2.6	Presto III programming algorithm .....	9
2.7	Program Inhibit .....	10
2.8	Program Verify .....	10
2.9	Electronic Signature .....	10
2.10	Erase operation (applies to UV EPROM) .....	11
<b>3</b>	<b>Maximum ratings</b> .....	<b>12</b>
<b>4</b>	<b>DC and AC characteristics</b> .....	<b>13</b>
<b>5</b>	<b>Package mechanical data</b> .....	<b>19</b>
5.1	42-pin Ceramic Frit-seal DIP with window (FDIP42WB) .....	19
5.2	42-pin Plastic DIP, 600 mils width (PDIP42) .....	20
5.3	42-lead Shrink Plastic DIP, 600 mils width (SDIP42) .....	21
5.4	44-lead Square Plastic Leaded Chip Carrier (PLCC44) .....	22
5.5	44-lead Plastic Small Outline, 525 mils body width (SO44) .....	23
<b>6</b>	<b>Part numbering</b> .....	<b>24</b>
<b>7</b>	<b>Revision history</b> .....	<b>25</b>

## List of tables

Table 1.	Signal names	6
Table 2.	Operating Modes	8
Table 3.	Electronic Signature	11
Table 4.	Absolute Maximum Ratings	12
Table 5.	Read Mode DC Characteristics	13
Table 6.	Programming Mode DC Characteristics	13
Table 7.	Capacitance	14
Table 8.	AC Measurement Conditions	14
Table 9.	Read Mode AC Characteristics (-50 and -70)	15
Table 10.	Read Mode AC Characteristics (-90, -100, -120 and -150)	16
Table 11.	Programming Mode AC Characteristics	18
Table 12.	FDIP42WB package mechanical data	19
Table 13.	PDIP42 package mechanical data	20
Table 14.	SDIP42 package mechanical data	21
Table 15.	PLCC44 package mechanical data	22
Table 16.	SO44 package mechanical data	23
Table 17.	Ordering Information Scheme	24
Table 18.	Document revision history	25

## List of figures

Figure 1.	Logic diagram . . . . .	5
Figure 2.	PLCC Connections . . . . .	6
Figure 3.	DIP Connections . . . . .	7
Figure 4.	SO Connections . . . . .	7
Figure 5.	Programming Flowchart . . . . .	10
Figure 6.	AC Testing Input Output Waveform . . . . .	14
Figure 7.	AC Testing Load Circuit . . . . .	14
Figure 8.	Word-Wide Read Mode AC Waveforms . . . . .	16
Figure 9.	Byte-Wide Read Mode AC Waveforms . . . . .	17
Figure 10.	BYTE Transition AC Waveforms . . . . .	17
Figure 11.	Programming and Verify Modes AC Waveforms . . . . .	18
Figure 12.	FDIP42WB package outline . . . . .	19
Figure 13.	PDIP42 package outline . . . . .	20
Figure 14.	SDIP42 package outline . . . . .	21
Figure 15.	PLCC44 package outline . . . . .	22
Figure 16.	SO44 package outline . . . . .	23

# 1 Summary description

The M27C160 is a 16-Mbit EPROM offered in two ranges UV (Ultraviolet Erase) and OTP (One-Time Programmable). It is ideally suited for microprocessor systems requiring large data or program storage and is organized as either 2 Mbit words of 8 bits or 1 Mbit word of 16 bits. The pin-out is compatible with a 16-Mbit Mask ROM.

The FDIP42W (window ceramic frit-seal package) has a transparent lid which enables the user to expose the chip to ultraviolet light to erase the bit pattern. A new pattern can then be written rapidly to the device by following the programming procedure.

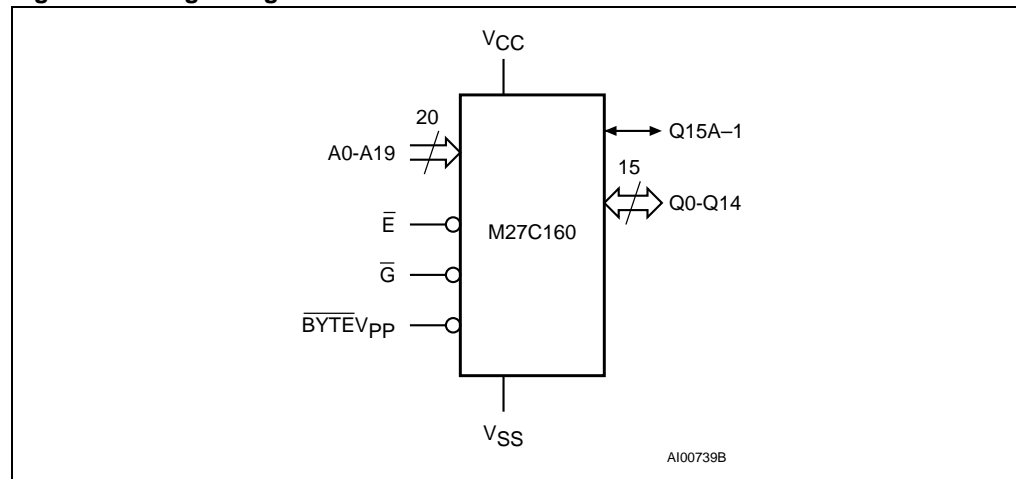
For applications where the content is programmed only one time and erasure is not required, the M27C160 is offered in PDIP42, SDIP42, PLCC44 and SO44 packages.

In order to meet environmental requirements, ST offers the M27C160 in ECOPACK® packages. ECOPACK packages are Lead-free. The category of second Level Interconnect is marked on the package and on the inner box label, in compliance with JEDEC Standard JESD97. The maximum ratings related to soldering conditions are also marked on the inner box label.

ECOPACK is an ST trademark. ECOPACK specifications are available at: [www.st.com](http://www.st.com).

See [Figure 1: Logic diagram](#) and [Table 1: Signal names](#) for a brief overview of the signals connected to this device.

**Figure 1. Logic diagram**



**Table 1. Signal names**

Signal	Description
A0-A19	Address Inputs
Q0-Q7	Data Outputs
Q8-Q14	Data Outputs
Q15A-1	Data Output / Address Input
$\bar{E}$	Chip Enable
$\bar{G}$	Output Enable
BYTEV <sub>PP</sub>	Byte Mode / Program Supply
V <sub>CC</sub>	Supply Voltage
V <sub>SS</sub>	Ground
NC	Not Connected Internally

**Figure 2. PLCC Connections**

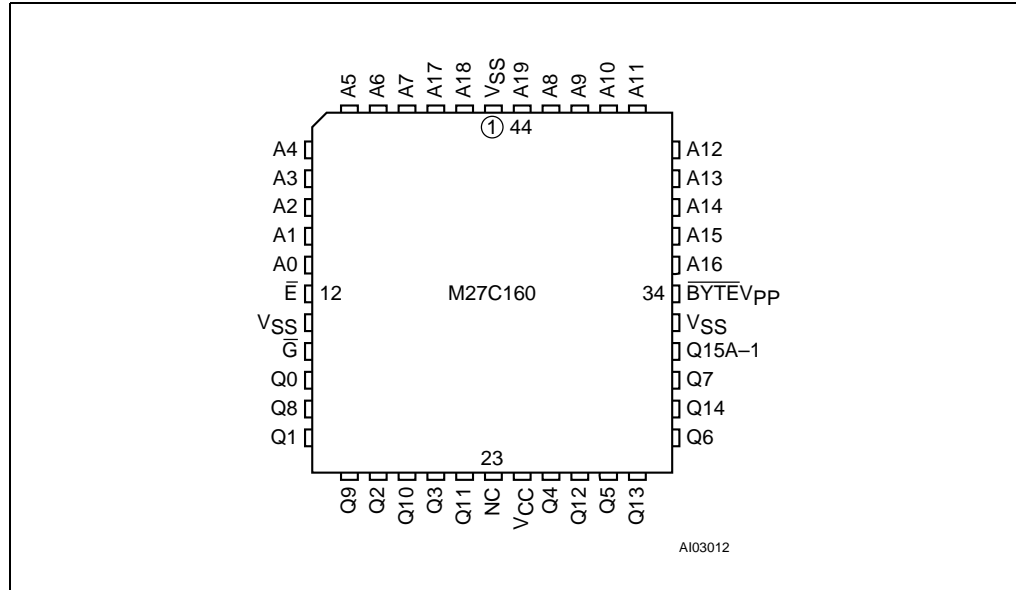


Figure 3. DIP Connections

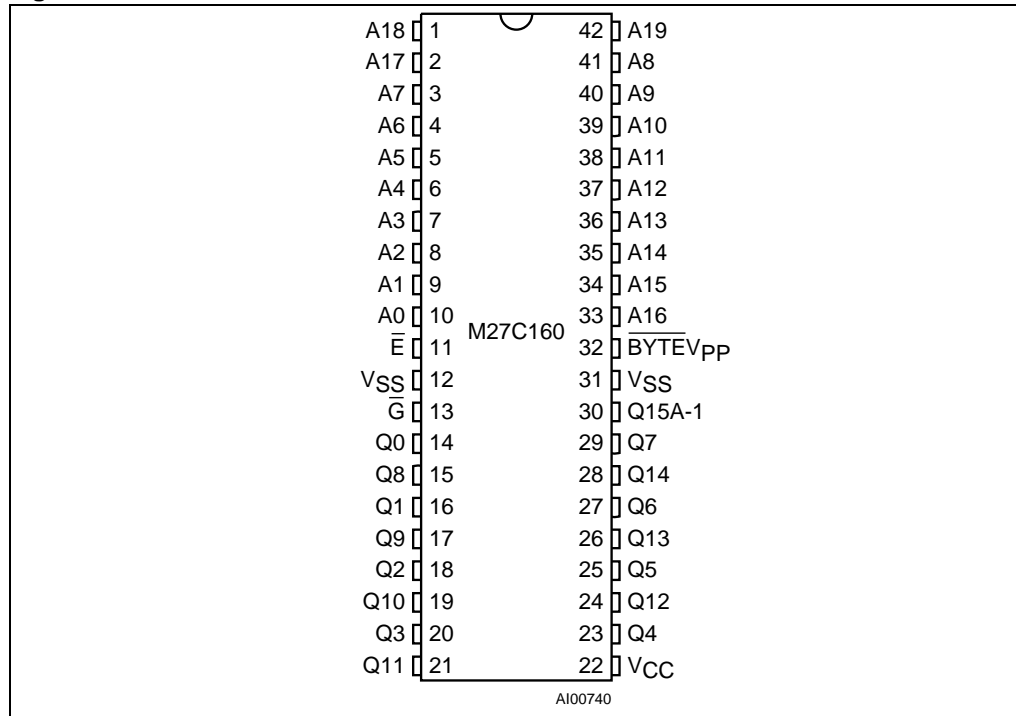
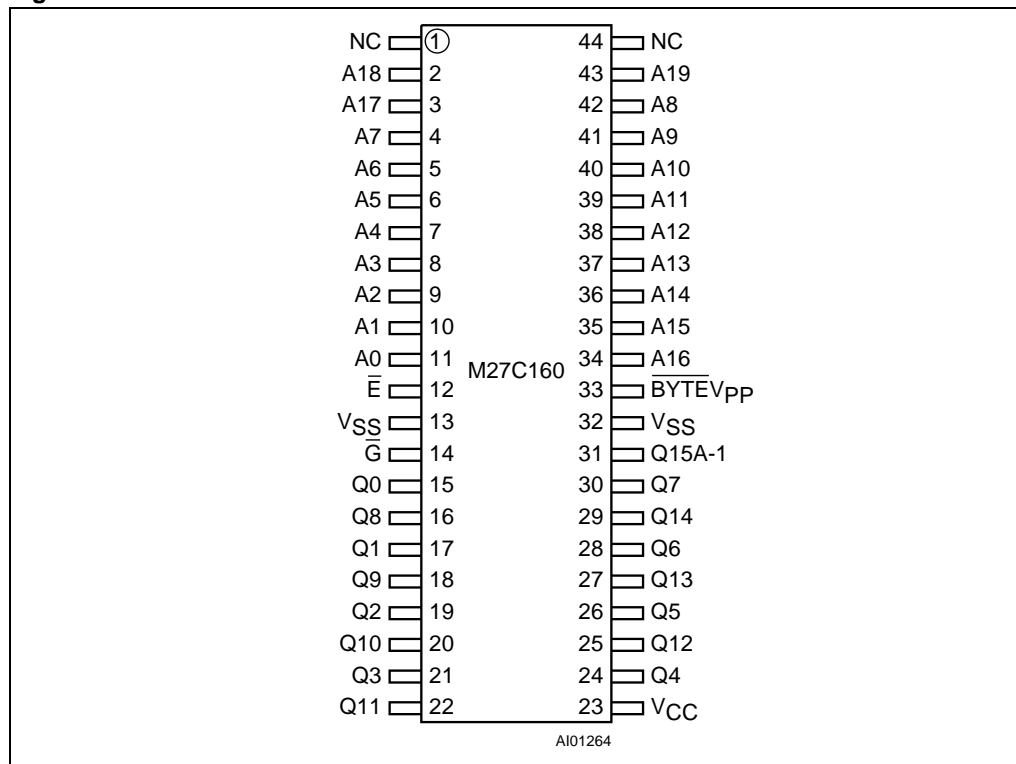


Figure 4. SO Connections



## 2 Device description

Table 2 lists the operating modes of the M27C160. A single power supply is required in the read mode. All inputs are TTL compatible except for  $V_{PP}$  and 12V on A9 for the Electronic Signature.

**Table 2. Operating Modes**

Mode	$\bar{E}$	$\bar{G}$	$\overline{BYTEV_{PP}}$	A9	Q15A-1	Q8-Q14	Q7-Q0
Read Word-wide	$V_{IL}$	$V_{IL}$	$V_{IH}$	X	Data Out	Data Out	Data Out
Read Byte-wide Upper	$V_{IL}$	$V_{IL}$	$V_{IL}$	X	$V_{IH}$	Hi-Z	Data Out
Read Byte-wide Lower	$V_{IL}$	$V_{IL}$	$V_{IL}$	X	$V_{IL}$	Hi-Z	Data Out
Output Disable	$V_{IL}$	$V_{IH}$	X	X	Hi-Z	Hi-Z	Hi-Z
Program	$V_{IL}$ Pulse	$V_{IH}$	$V_{PP}$	X	Data In	Data In	Data In
Verify	$V_{IH}$	$V_{IL}$	$V_{PP}$	X	Data Out	Data Out	Data Out
Program Inhibit	$V_{IH}$	$V_{IH}$	$V_{PP}$	X	Hi-Z	Hi-Z	Hi-Z
Standby	$V_{IH}$	X	X	X	Hi-Z	Hi-Z	Hi-Z
Electronic Signature	$V_{IL}$	$V_{IL}$	$V_{IH}$	$V_{ID}$	Code	Codes	Codes

Note:  $X = V_{IH}$  or  $V_{IL}$ ,  $V_{ID} = 12V \pm 0.5V$ .

### 2.1 Read mode

The M27C160 has two organisations, Word-wide and Byte-wide. The organisation is selected by the signal level on the  $\overline{BYTEV_{PP}}$  pin. When  $\overline{BYTEV_{PP}}$  is at  $V_{IH}$  the Word-wide organisation is selected and the Q15A-1 pin is used for Q15 Data Output. When the  $\overline{BYTEV_{PP}}$  pin is at  $V_{IL}$  the Byte-wide organisation is selected and the Q15A-1 pin is used for the Address Input A-1. When the memory is logically regarded as 16 bit wide, but read in the Byte-wide organisation, then with A-1 at  $V_{IL}$  the lower 8 bits of the 16 bit data are selected and with A-1 at  $V_{IH}$  the upper 8 bits of the 16 bit data are selected.

The M27C160 has two control functions, both of which must be logically active in order to obtain data at the outputs. In addition the Word-wide or Byte-wide organisation must be selected.

Chip Enable ( $\bar{E}$ ) is the power control and should be used for device selection. Output Enable ( $\bar{G}$ ) is the output control and should be used to gate data to the output pins independent of device selection. Assuming that the addresses are stable, the address access time ( $t_{AVQV}$ ) is equal to the delay from  $\bar{E}$  to output ( $t_{ELQV}$ ). Data is available at the output after a delay of  $t_{GLQV}$  from the falling edge of  $\bar{G}$ , assuming that  $\bar{E}$  has been low and the addresses have been stable for at least  $t_{AVQV} - t_{GLQV}$ .

### 2.2 Standby mode

The M27C160 has a standby mode which reduces the active current from 50mA to 100 $\mu$ A. The M27C160 is placed in the standby mode by applying a CMOS high signal to the  $\bar{E}$  input.



When in the standby mode, the outputs are in a high impedance state, independent of the  $\overline{G}$  input.

## 2.3 Two-line output control

Because EPROMs are usually used in larger memory arrays, this product features a 2-line control function which accommodates the use of multiple memory connection. The two line control function allows:

- the lowest possible memory power dissipation,
- complete assurance that output bus contention will not occur.

For the most efficient use of these two control lines,  $\overline{E}$  should be decoded and used as the primary device selecting function, while  $\overline{G}$  should be made a common connection to all devices in the array and connected to the  $\overline{READ}$  line from the system control bus. This ensures that all deselected memory devices are in their low power standby mode and that the output pins are only active when data is required from a particular memory device.

## 2.4 System considerations

The power switching characteristics of Advanced CMOS EPROMs require careful decoupling of the supplies to the devices. The supply current  $I_{CC}$  has three segments of importance to the system designer: the standby current, the active current and the transient peaks that are produced by the falling and rising edges of  $\overline{E}$ .

The magnitude of the transient current peaks is dependent on the capacitive and inductive loading of the device outputs. The associated transient voltage peaks can be suppressed by complying with the two line output control and by properly selected decoupling capacitors. It is recommended that a 0.1  $\mu$ F ceramic capacitor is used on every device between  $V_{CC}$  and  $V_{SS}$ . This should be a high frequency type of low inherent inductance and should be placed as close as possible to the device. In addition, a 4.7  $\mu$ F electrolytic capacitor should be used between  $V_{CC}$  and  $V_{SS}$  for every eight devices.

This capacitor should be mounted near the power supply connection point. The purpose of this capacitor is to overcome the voltage drop caused by the inductive effects of PCB traces.

## 2.5 Programming

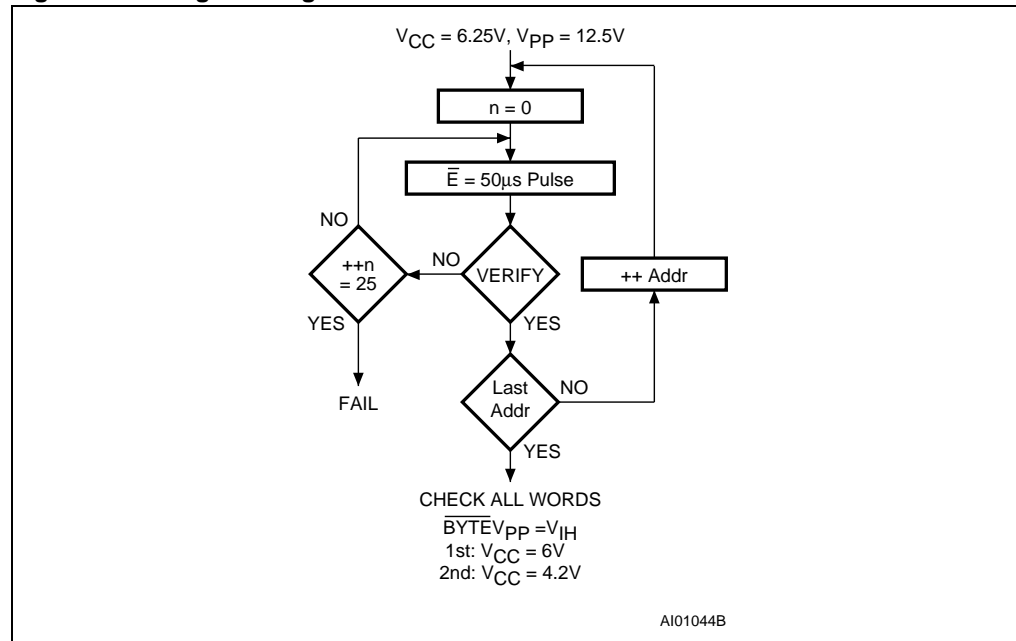
When delivered (and after each erasure for UV EPROM), all bits of the M27C160 are in the '1' state. Data is introduced by selectively programming '0's into the desired bit locations. Although only '0's will be programmed, both '1's and '0's can be present in the data word. The only way to change a '0' to a '1' is by die exposure to ultraviolet light (UV EPROM). The M27C160 is in the programming mode when  $V_{PP}$  input is at 12.5V,  $\overline{G}$  is at  $V_{IH}$  and  $\overline{E}$  is pulsed to  $V_{IL}$ . The data to be programmed is applied to 16 bits in parallel to the data output pins. The levels required for the address and data inputs are TTL.  $V_{CC}$  is specified to be  $6.25V \pm 0.25V$ .

## 2.6 Presto III programming algorithm

The Presto III Programming Algorithm allows the whole array to be programmed with a guaranteed margin in a typical time of 52.5 seconds. Programming with Presto III consists of

applying a sequence of 50 $\mu$ s program pulses to each word until a correct verify occurs (see [Figure 5](#)). During programming and verify operation a Margin mode circuit is automatically activated to guarantee that each cell is programmed with enough margin. No overprogram pulse is applied since the verify in Margin mode provides the necessary margin to each programmed cell.

**Figure 5. Programming Flowchart**



## 2.7 Program Inhibit

Programming of multiple M27C160s in parallel with different data is also easily accomplished. Except for  $\overline{E}$ , all like inputs including  $\overline{G}$  of the parallel M27C160 may be common. A TTL low level pulse applied to a M27C160's  $\overline{E}$  input and  $V_{PP}$  at 12.5V, will program that M27C160. A high level  $\overline{E}$  input inhibits the other M27C160s from being programmed.

## 2.8 Program Verify

A verify (read) should be performed on the programmed bits to determine that they were correctly programmed. The verify is accomplished with  $\overline{E}$  at  $V_{IH}$  and  $\overline{G}$  at  $V_{IL}$ ,  $V_{PP}$  at 12.5V and  $V_{CC}$  at 6.25V.

## 2.9 Electronic Signature

The Electronic Signature (ES) mode allows the reading out of a binary code from an EPROM that will identify its manufacturer and type. This mode is intended for use by programming equipment to automatically match the device to be programmed with its corresponding programming algorithm. The ES mode is functional in the  $25^{\circ}\text{C} \pm 5^{\circ}\text{C}$

ambient temperature range that is required when programming the M27C160. To activate the ES mode, the programming equipment must force 11.5V to 12.5V on address line A9 of the M27C160, with  $V_{PP} = V_{CC} = 5V$ . Two identifier bytes may then be sequenced from the device outputs by toggling address line A0 from  $V_{IL}$  to  $V_{IH}$ . All other address lines must be held at  $V_{IL}$  during Electronic Signature mode. Byte 0 ( $A0 = V_{IL}$ ) represents the manufacturer code and byte 1 ( $A0 = V_{IH}$ ) the device identifier code. For the STMicroelectronics M27C160, these two identifier bytes are given in [Table 3](#) and can be read-out on outputs Q7 to Q0.

**Table 3. Electronic Signature**

Identifier	A0	Q7	Q6	Q5	Q4	Q3	Q2	Q1	Q0	Hex Data
Manufacturer's Code	$V_{IL}$	0	0	1	0	0	0	0	0	20h
Device Code	$V_{IH}$	1	0	1	1	0	0	0	1	B1h

*Note:* Outputs Q15-Q8 are set to '0'.

## 2.10 Erasure operation (applies to UV EPROM)

The erasure characteristics of the M27C160 is such that erasure begins when the cells are exposed to light with wavelengths shorter than approximately 4000 Å. It should be noted that sunlight and some type of fluorescent lamps have wavelengths in the 3000-4000 Å range. Research shows that constant exposure to room level fluorescent lighting could erase a typical M27C160 in about 3 years, while it would take approximately 1 week to cause erasure when exposed to direct sunlight. If the M27C160 is to be exposed to these types of lighting conditions for extended periods of time, it is suggested that opaque labels be put over the M27C160 window to prevent unintentional erasure. The recommended erasure procedure for M27C160 is exposure to short wave ultraviolet light which has a wavelength of 2537 Å. The integrated dose (i.e. UV intensity x exposure time) for erasure should be a minimum of 30 W-sec/cm<sup>2</sup>. The erasure time with this dosage is approximately 30 to 40 minutes using an ultraviolet lamp with 12000 µW/cm<sup>2</sup> power rating. The M27C160 should be placed within 2.5cm (1 inch) of the lamp tubes during the erasure. Some lamps have a filter on their tubes which should be removed before erasure.

### 3 Maximum ratings

**Table 4. Absolute Maximum Ratings <sup>(1)</sup>**

Symbol	Parameter	Value	Unit
$T_A$	Ambient Operating Temperature <sup>(2)</sup>	-40 to 125	°C
$T_{BIAS}$	Temperature Under Bias	-50 to 125	°C
$T_{STG}$	Storage Temperature	-65 to 150	°C
$V_{IO}$ <sup>(3)</sup>	Input or Output Voltage (except A9)	-2 to 7	V
$V_{CC}$	Supply Voltage	-2 to 7	V
$V_{A9}$ <sup>(3)</sup>	A9 Voltage	-2 to 13.5	V
$V_{PP}$	Program Supply Voltage	-2 to 14	V

1. Except for the rating "Operating Temperature Range", stresses above those listed in the Table "Absolute Maximum Ratings" may cause permanent damage to the device. These are stress ratings only and operation of the device at these or any other conditions above those indicated in the Operating sections of this specification is not implied. Exposure to Absolute Maximum Rating conditions for extended periods may affect device reliability. Refer also to the STMicroelectronics SURE Program and other relevant quality documents.
2. Depends on range.
3. Minimum DC voltage on Input or Output is -0.5V with possible undershoot to -2.0V for a period less than 20ns.  
Maximum DC voltage on Output is VCC +0.5V with possible overshoot to VCC +2V for a period less than 20ns.

## 4 DC and AC characteristics

$T_A = 0$  to  $70$  °C or  $-40$  to  $85$  °C;  $V_{CC} = 5V \pm 5\%$  or  $5V \pm 10\%$ ;  $V_{PP} = V_{CC}$

**Table 5. Read Mode DC Characteristics (1)**

Symbol	Parameter	Test Condition	Min.	Max.	Unit
$I_{LI}$	Input Leakage Current	$0V \leq V_{IN} \leq V_{CC}$		$\pm 1$	$\mu A$
$I_{LO}$	Output Leakage Current	$0V \leq V_{OUT} \leq V_{CC}$		$\pm 10$	$\mu A$
$I_{CC}$	Supply Current	$\bar{E} = V_{IL}, \bar{G} = V_{IL}, I_{OUT} = 0mA, f = 8MHz$		70	mA
		$\bar{E} = V_{IL}, \bar{G} = V_{IL}, I_{OUT} = 0mA, f = 5MHz$		50	mA
$I_{CC1}$	Supply Current (Standby) TTL	$\bar{E} = V_{IH}$		1	mA
$I_{CC2}$	Supply Current (Standby) CMOS	$\bar{E} > V_{CC} - 0.2V$		100	$\mu A$
$I_{PP}$	Program Current	$V_{PP} = V_{CC}$		10	$\mu A$
$V_{IL}$	Input Low Voltage		-0.3	0.8	V
$V_{IH}^{(2)}$	Input High Voltage		2	$V_{CC} + 1$	V
$V_{OL}$	Output Low Voltage	$I_{OL} = 2.1mA$		0.4	V
$V_{OH}$	Output High Voltage TTL	$I_{OH} = -400\mu A$	2.4		V

1.  $V_{CC}$  must be applied simultaneously with or before  $V_{PP}$  and removed simultaneously or after  $V_{PP}$ .

2. Maximum DC voltage on Output is  $V_{CC} + 0.5V$ .

$T_A = 25$  °C;  $V_{CC} = 6.25V \pm 0.25V$ ;  $V_{PP} = 12.5V \pm 0.25V$

**Table 6. Programming Mode DC Characteristics (1)**

Symbol	Parameter	Test Condition	Min.	Max.	Unit
$I_{LI}$	Input Leakage Current	$0 \leq V_{IN} \leq V_{CC}$		$\pm 1$	$\mu A$
$I_{CC}$	Supply Current			50	mA
$I_{PP}$	Program Current	$\bar{E} = V_{IL}$		50	mA
$V_{IL}$	Input Low Voltage		-0.3	0.8	V
$V_{IH}$	Input High Voltage		2.4	$V_{CC} + 0.5$	V
$V_{OL}$	Output Low Voltage	$I_{OL} = 2.1mA$		0.4	V
$V_{OH}$	Output High Voltage TTL	$I_{OH} = -2.5mA$	3.5		V
$V_{ID}$	A9 Voltage		11.5	12.5	V

1.  $V_{CC}$  must be applied simultaneously with or before  $V_{PP}$  and removed simultaneously or after  $V_{PP}$ .

**Table 7. Capacitance (1)**

Symbol	Parameter	Test Condition	Min.	Max.	Unit
C <sub>IN</sub>	Input Capacitance (except BYTEV <sub>PP</sub> )	V <sub>IN</sub> = 0V		10	pF
	Input Capacitance (BYTEV <sub>PP</sub> )	V <sub>IN</sub> = 0V		120	pF
C <sub>OUT</sub>	Output Capacitance	V <sub>OUT</sub> = 0V		12	pF

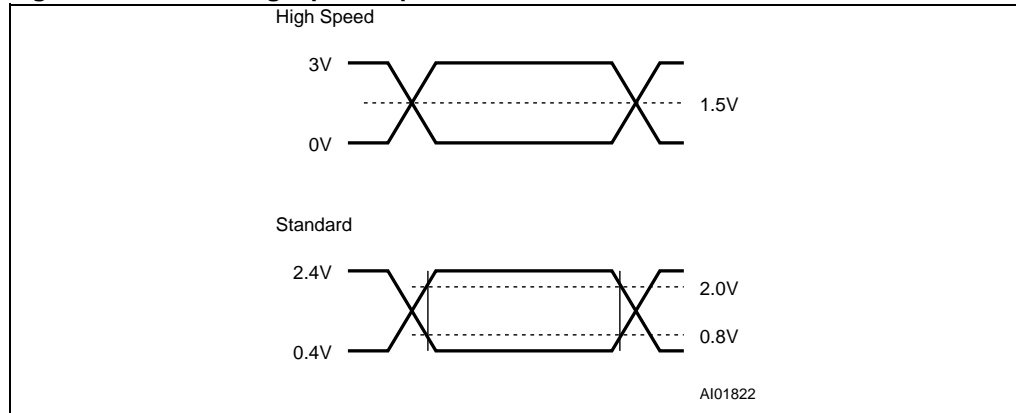
1. Sampled only, not 100% tested.

T<sub>A</sub> = 25 °C, f = 1 MHz

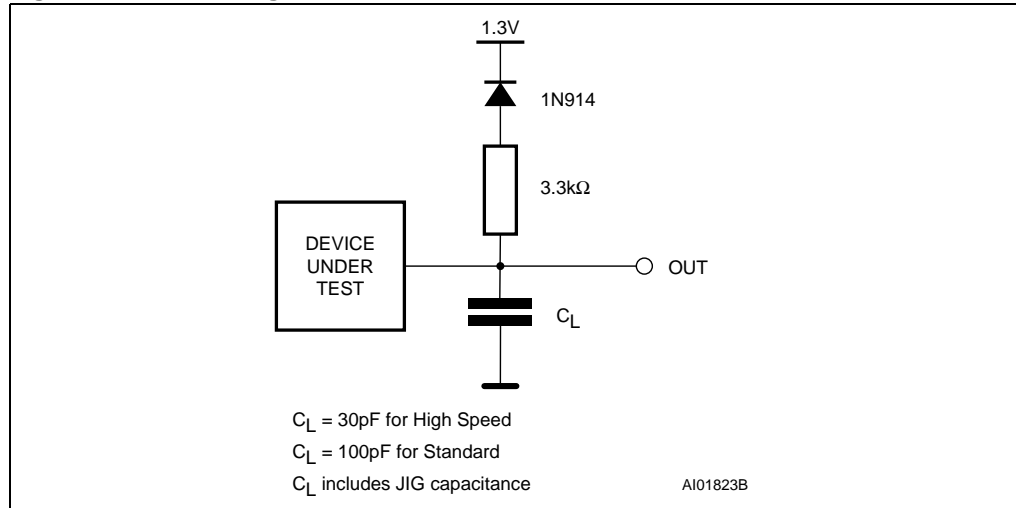
**Table 8. AC Measurement Conditions**

Parameter	High Speed	Standard
Input Rise and Fall Times	≤ 10ns	≤ 20ns
Input Pulse Voltages	0 to 3V	0.4V to 2.4V
Input and Output Timing Ref. Voltages	1.5V	0.8V and 2V

**Figure 6. AC Testing Input Output Waveform**



**Figure 7. AC Testing Load Circuit**



$T_A = 0$  to  $70$  °C or  $-40$  to  $85$  °C;  $V_{CC} = 5V \pm 5\%$  or  $5V \pm 10\%$ ;  $V_{PP} = V_{CC}$

**Table 9. Read Mode AC Characteristics <sup>(1)</sup> (-50 and -70)**

Symbol	Alt	Parameter	Test Condition	M27C160				Unit
				-50 <sup>(2)</sup>		-70 <sup>(2)</sup>		
				Min.	Max.	Min.	Max.	
$t_{AVQV}$	$t_{ACC}$	Address Valid to Output Valid	$\bar{E} = V_{IL}, \bar{G} = V_{IL}$		50		70	ns
$t_{BHQV}$	$t_{ST}$	BYTE High to Output Valid	$\bar{E} = V_{IL}, \bar{G} = V_{IL}$		50		70	ns
$t_{ELQV}$	$t_{CE}$	Chip Enable Low to Output Valid	$\bar{G} = V_{IL}$		50		70	ns
$t_{GLQV}$	$t_{OE}$	Output Enable Low to Output Valid	$\bar{E} = V_{IL}$		30		35	ns
$t_{BLQZ}$ <sup>(3)</sup>	$t_{STD}$	BYTE Low to Output Hi-Z	$\bar{E} = V_{IL}, \bar{G} = V_{IL}$		30		30	ns
$t_{EHQZ}$ <sup>(3)</sup>	$t_{DF}$	Chip Enable High to Output Hi-Z	$\bar{G} = V_{IL}$	0	25	0	25	ns
$t_{GHQZ}$ <sup>(3)</sup>	$t_{DF}$	Output Enable High to Output Hi-Z	$\bar{E} = V_{IL}$	0	25	0	25	ns
$t_{AXQX}$	$t_{OH}$	Address Transition to Output Transition	$\bar{E} = V_{IL}, \bar{G} = V_{IL}$	5		5		ns
$t_{BLQX}$	$t_{OH}$	BYTE Low to Output Transition	$\bar{E} = V_{IL}, \bar{G} = V_{IL}$	5		5		ns

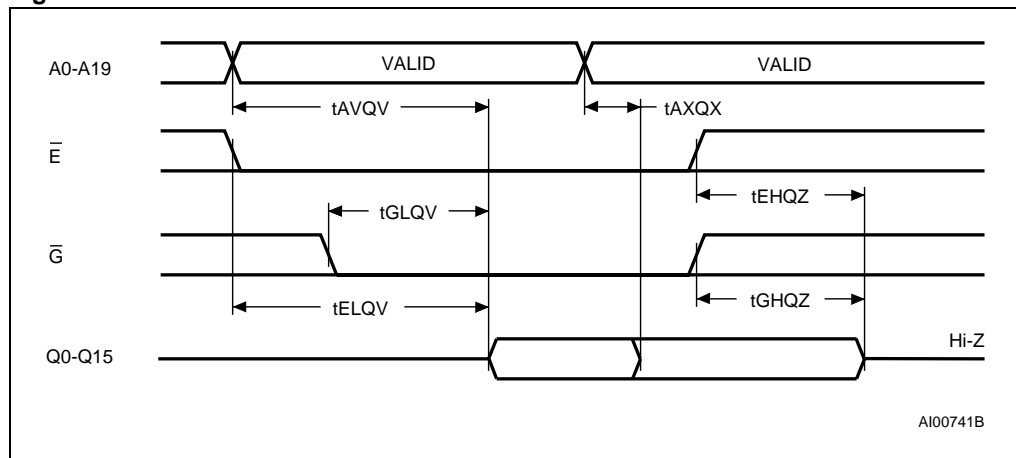
1.  $V_{CC}$  must be applied simultaneously with or before  $V_{PP}$  and removed simultaneously or after  $V_{PP}$ .
2. Speed obtained with High Speed AC measurement conditions.
3. Sampled only, not 100% tested.

**Table 10. Read Mode AC Characteristics<sup>(1)</sup> (-90, -100, -120 and -150)**

Symbol	Alt	Parameter	Test Condition	M27C160						Unit
				-90 <sup>(2)</sup>		-100 <sup>(2)</sup>		-120/-150 <sup>(2)</sup>		
				Min.	Max.	Min.	Max.	Min.	Max.	
t <sub>AVQV</sub>	t <sub>ACC</sub>	Address Valid to Output Valid	$\bar{E} = V_{IL}, \bar{G} = V_{IL}$		90		100		120	ns
t <sub>BHQV</sub>	t <sub>ST</sub>	BYTE High to Output Valid	$\bar{E} = V_{IL}, \bar{G} = V_{IL}$		90		100		120	ns
t <sub>ELQV</sub>	t <sub>CE</sub>	Chip Enable Low to Output Valid	$\bar{G} = V_{IL}$		90		100		120	ns
t <sub>GLQV</sub>	t <sub>OE</sub>	Output Enable Low to Output Valid	$\bar{E} = V_{IL}$		45		50		60	ns
t <sub>BLQZ</sub> <sup>(3)</sup>	t <sub>STD</sub>	BYTE Low to Output Hi-Z	$\bar{E} = V_{IL}, \bar{G} = V_{IL}$		30		40		50	ns
t <sub>EHQZ</sub> <sup>(3)</sup>	t <sub>DF</sub>	Chip Enable High to Output Hi-Z	$\bar{G} = V_{IL}$	0	30	0	40	0	50	ns
t <sub>GHQZ</sub> <sup>(3)</sup>	t <sub>DF</sub>	Output Enable High to Output Hi-Z	$\bar{E} = V_{IL}$	0	30	0	40	0	50	ns
t <sub>AXQX</sub>	t <sub>OH</sub>	Address Transition to Output Transition	$\bar{E} = V_{IL}, \bar{G} = V_{IL}$	5		5		5		ns
t <sub>BLQX</sub>	t <sub>OH</sub>	BYTE Low to Output Transition	$\bar{E} = V_{IL}, \bar{G} = V_{IL}$	5		5		5		ns

1. V<sub>CC</sub> must be applied simultaneously with or before V<sub>PP</sub> and removed simultaneously or after V<sub>PP</sub>.
2. Speed obtained with High Speed AC measurement conditions.
3. Sampled only, not 100% tested.

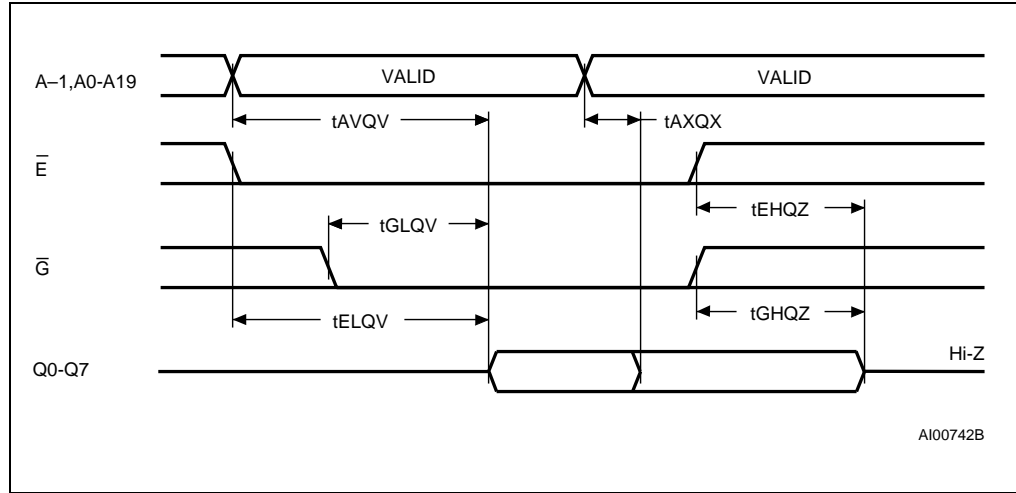
**Figure 8. Word-Wide Read Mode AC Waveforms**



Note:  $\overline{BYTE}V_{PP} = V_{IH}$ .

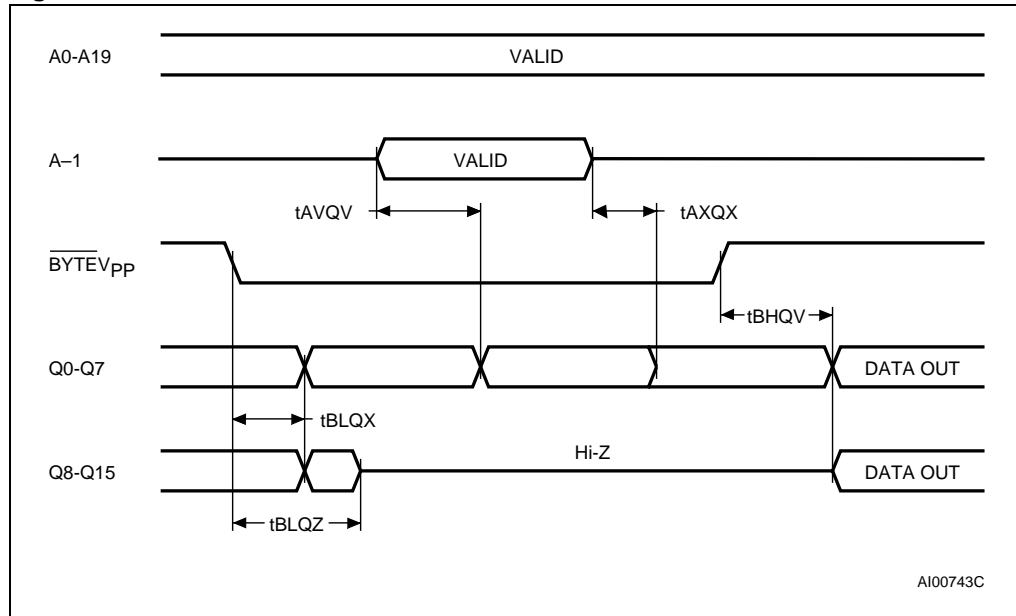


Figure 9. Byte-Wide Read Mode AC Waveforms



Note:  $\overline{BYTEV}_{PP} = V_{IL}$ .

Figure 10.  $\overline{BYTE}$  Transition AC Waveforms



Note: Chip Enable ( $\overline{E}$ ) and Output Enable ( $\overline{G}$ ) =  $V_{IL}$ .

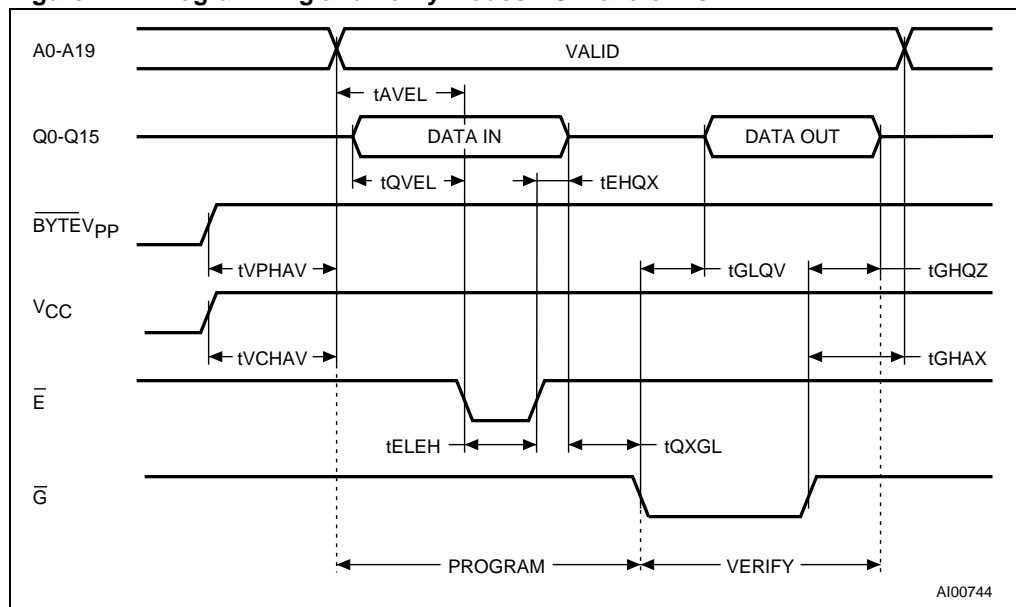
$T_A = 25\text{ }^\circ\text{C}$ ;  $V_{CC} = 6.25\text{V} \pm 0.25\text{V}$ ;  $V_{PP} = 12.5\text{V} \pm 0.25\text{V}$

**Table 11. Programming Mode AC Characteristics<sup>(1)</sup>**

Symbol	Alt	Parameter	Test Condition	Min	Max	Unit
$t_{AVEL}$	$t_{AS}$	Address Valid to Chip Enable Low		2		$\mu\text{s}$
$t_{QVEL}$	$t_{DS}$	Input Valid to Chip Enable Low		2		$\mu\text{s}$
$t_{VPHAV}$	$t_{VPS}$	$V_{PP}$ High to Address Valid		2		$\mu\text{s}$
$t_{VCHAV}$	$t_{VCS}$	$V_{CC}$ High to Address Valid		2		$\mu\text{s}$
$t_{ELEH}$	$t_{PW}$	Chip Enable Program Pulse Width		45	55	$\mu\text{s}$
$t_{EHQX}$	$t_{DH}$	Chip Enable High to Input Transition		2		$\mu\text{s}$
$t_{QXGL}$	$t_{OES}$	Input Transition to Output Enable Low		2		$\mu\text{s}$
$t_{GLQV}$	$t_{OE}$	Output Enable Low to Output Valid			120	ns
$t_{GHQZ}^{(2)}$	$t_{DFP}$	Output Enable High to Output Hi-Z		0	130	ns
$t_{GHAX}$	$t_{AH}$	Output Enable High to Address Transition		0		ns

- $V_{CC}$  must be applied simultaneously with or before  $V_{PP}$  and removed simultaneously or after  $V_{PP}$ .
- Sampled only, not 100% tested.

**Figure 11. Programming and Verify Modes AC Waveforms**



## 5 Package mechanical data

### 5.1 42-pin Ceramic Frit-seal DIP with window (FDIP42WB)

Figure 12. FDIP42WB package outline

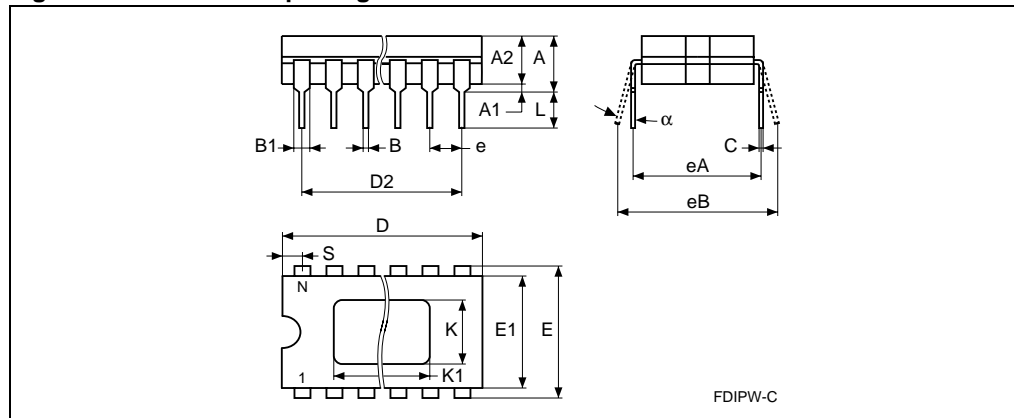


Table 12. FDIP42WB package mechanical data

Symbol	millimeters			inches		
	Min.	Typ.	Max.	Min.	Typ.	Max.
A			5.71			0.225
A1	0.50		1.78	0.020		0.070
A2	3.90		5.08	0.154		0.200
B	0.40		0.55	0.016		0.022
B1	1.27		1.52	0.050		0.060
C	0.22		0.31	0.009		0.012
D			54.81			2.158
D2		50.80			2.000	
E		15.24			0.600	
E1	14.50		14.90	0.571		0.587
e	2.29		2.79	0.090		0.110
eA	15.40		15.80	0.606		0.622
eB	16.17		18.32	0.637		0.721
K	9.32		9.47	0.367		0.373
K1	11.30		11.55	0.445		0.455
L	3.18		4.10	0.125		0.161
S	1.52		2.49	0.060		0.098
$\alpha$	4°		15°	4°		15°
N		42			42	

## 5.2 42-pin Plastic DIP, 600 mils width (PDIP42)

Figure 13. PDIP42 package outline

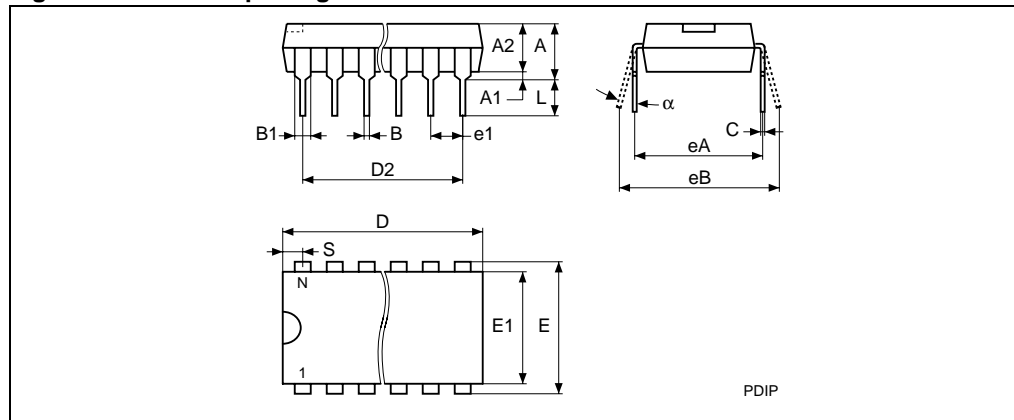


Table 13. PDIP42 package mechanical data

Symbol	millimeters			inches		
	Min.	Typ.	Max.	Min.	Typ.	Max.
A			5.08			0.200
A1	0.25			0.010		
A2	3.56		4.06	0.140		0.160
B	0.38		0.53	0.015		0.021
B1	1.27		1.65	0.050		0.065
C	0.20		0.36	0.008		0.014
D	52.20		52.71	2.055		2.075
D2		50.80			2.000	
E		15.24			0.600	
E1	13.59		13.84	0.535		0.545
e1		2.54			0.100	
eA		14.99			0.590	
eB	15.24		17.78	0.600		0.700
L	3.18		3.43	0.125		0.135
S	0.86		1.37	0.034		0.054
α	0°		10°	0°		10°
N		42			42	

### 5.3 42-lead Shrink Plastic DIP, 600 mils width (SDIP42)

Figure 14. SDIP42 package outline

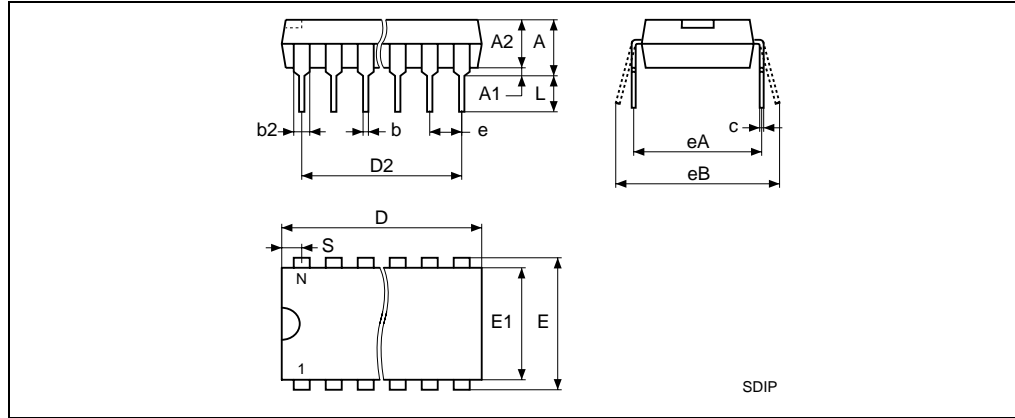


Table 14. SDIP42 package mechanical data

Symbol	millimeters			inches		
	Min.	Typ.	Max.	Min.	Typ.	Max.
A			5.08			0.200
A1	0.51			0.020		
A2	3.05	3.81	4.57	0.120	0.150	0.180
b	0.38	0.46	0.56	0.015	0.018	0.022
b2	0.89	1.02	1.14	0.035	0.040	0.045
c	0.23	0.25	0.38	0.009	0.010	0.015
D	36.58	36.83	37.08	1.440	1.450	1.460
D2		35.60			1.402	
e		1.78			0.070	
E	15.24		16.00	0.600		0.630
E1	12.70	13.72	14.48	0.500	0.540	0.570
eA		15.24			0.600	
eB			18.54			0.730
L	2.54	3.30	3.56	0.100	0.130	0.140
S		0.64			0.025	
N		42			42	

### 5.4 44-lead Square Plastic Leaded Chip Carrier (PLCC44)

Figure 15. PLCC44 package outline

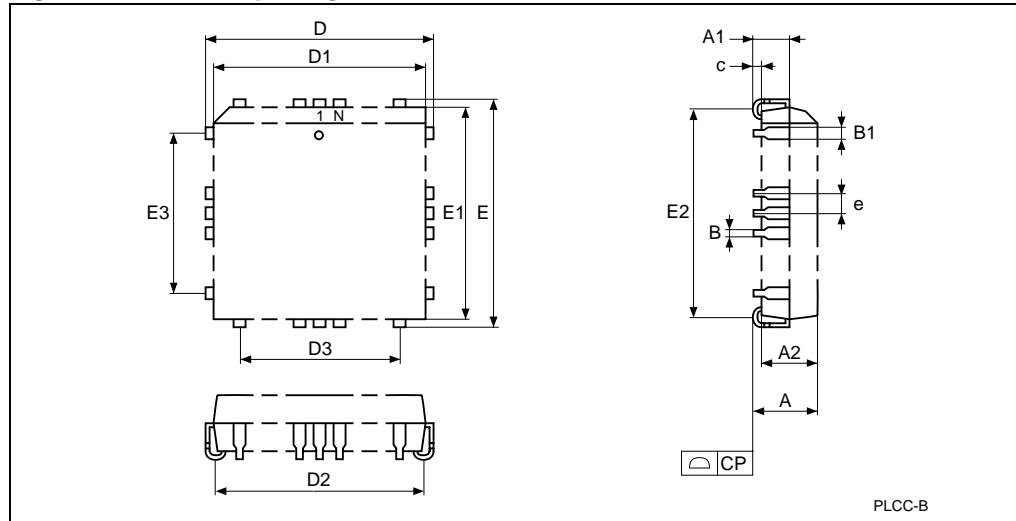


Table 15. PLCC44 package mechanical data

Symbol	millimeters			inches		
	Min.	Typ.	Max.	Min.	Typ.	Max.
A	4.200		4.570	0.1654		0.1799
A1	2.290		3.040	0.0902		0.1197
A2	3.650		3.700	0.1437		0.1457
B	0.331		0.533	0.0130		0.0210
B1	0.661		0.812	0.0260		0.0320
CP			0.101			0.0040
c		0.510			0.0201	
D	17.400		17.650	0.6850		0.6949
D1	16.510		16.662	0.6500		0.6560
D2	14.990		16.000	0.5902		0.6299
D3		12.700			0.5000	
E	17.400		17.650	0.6850		0.6949
E1	16.510		16.660	0.6500		0.6559
E2	14.990		16.000	0.5902		0.6299
E3		12.700			0.5000	
e		1.270			0.0500	
N		44			44	

## 5.5 44-lead Plastic Small Outline, 525 mils body width (SO44)

Figure 16. SO44 package outline

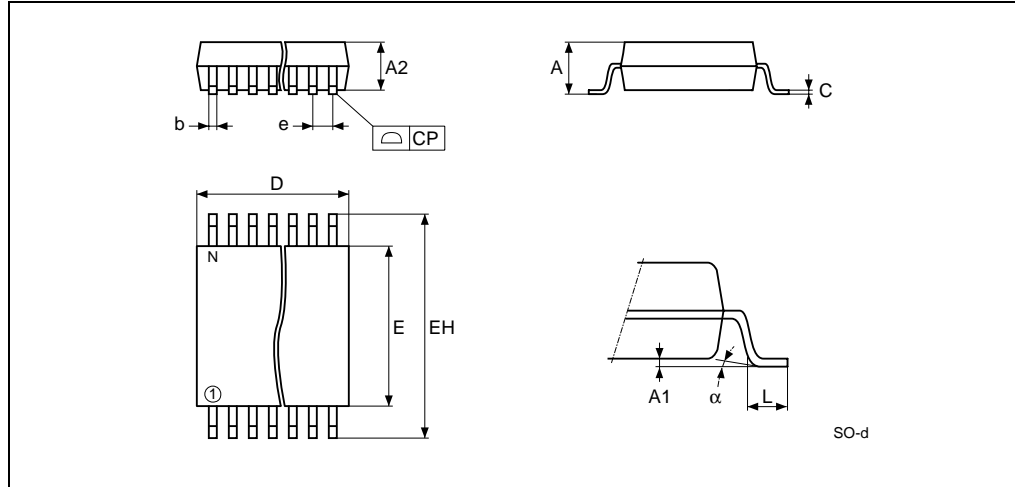


Table 16. SO44 package mechanical data

Symbol	millimeters			inches		
	Min.	Typ.	Max.	Min.	Typ.	Max.
A			2.80			0.1102
A1	0.10			0.0039		
A2	2.20	2.30	2.40	0.0866	0.0906	0.0945
b	0.35	0.40	0.50	0.0138	0.0157	0.0197
C	0.10	0.15	0.20	0.0039	0.0059	0.0079
CP			0.08			0.0030
D	28.00	28.20	28.40	1.1024	1.1102	1.1181
E	13.20	13.30	13.50	0.5197	0.5236	0.5315
EH	15.75	16.00	16.25	0.6201	0.6299	0.6398
e		1.27			0.0500	
L		0.80			0.0315	
$\alpha$			8°			8°
N		44			44	

## 6 Part numbering

**Table 17. Ordering Information Scheme**

Example:	M27C160	-70	X	M	1
<b>Device Type</b> M27					
<b>Supply Voltage</b> C = 5V					
<b>Device Function</b> 160 = 16 Mbit (2mb x 8 or 1Mb x 16)					
<b>Speed</b> -50 <sup>(1)</sup> = 50 ns -70 <sup>(1)</sup> = 70 ns -90 = 90 ns -100 = 100 ns -120 = 120 ns -150 = 150 ns					
<b>V<sub>CC</sub> Tolerance</b> blank = ± 10% X = ± 5%					
<b>Package</b> F = FDIP42W B = PDIP42 S = SDIP42 K = PLCC44 M = SO44					
<b>Temperature Range</b> 1 = 0 to 70 °C 6 = -40 to 85 °C					

1. High Speed, see AC Characteristics section for further information.

For a list of available options (Speed, Package, etc...) or for further information on any aspect of this device, please contact the STMicroelectronics Sales Office nearest to you.



## 7 Revision history

Table 18. Document revision history

Date	Revision	Changes
January 1999	1	First Issue
20-Sep-00	2	AN620 Reference removed
19-Jul-01	3	SDIP42 package added
17-Jan-02	4	50ns speed class added, SO44 package mechanical data and drawing clarified
12-Apr-2006	5	Converted to new template. Updated ECOPACK® information. Removed Tape & Reel info.

**Please Read Carefully:**

Information in this document is provided solely in connection with ST products. STMicroelectronics NV and its subsidiaries ("ST") reserve the right to make changes, corrections, modifications or improvements, to this document, and the products and services described herein at any time, without notice.

All ST products are sold pursuant to ST's terms and conditions of sale.

Purchasers are solely responsible for the choice, selection and use of the ST products and services described herein, and ST assumes no liability whatsoever relating to the choice, selection or use of the ST products and services described herein.

No license, express or implied, by estoppel or otherwise, to any intellectual property rights is granted under this document. If any part of this document refers to any third party products or services it shall not be deemed a license grant by ST for the use of such third party products or services, or any intellectual property contained therein or considered as a warranty covering the use in any manner whatsoever of such third party products or services or any intellectual property contained therein.

**UNLESS OTHERWISE SET FORTH IN ST'S TERMS AND CONDITIONS OF SALE ST DISCLAIMS ANY EXPRESS OR IMPLIED WARRANTY WITH RESPECT TO THE USE AND/OR SALE OF ST PRODUCTS INCLUDING WITHOUT LIMITATION IMPLIED WARRANTIES OF MERCHANTABILITY, FITNESS FOR A PARTICULAR PURPOSE (AND THEIR EQUIVALENTS UNDER THE LAWS OF ANY JURISDICTION), OR INFRINGEMENT OF ANY PATENT, COPYRIGHT OR OTHER INTELLECTUAL PROPERTY RIGHT.**

**UNLESS EXPRESSLY APPROVED IN WRITING BY AN AUTHORIZE REPRESENTATIVE OF ST, ST PRODUCTS ARE NOT DESIGNED, AUTHORIZED OR WARRANTED FOR USE IN MILITARY, AIR CRAFT, SPACE, LIFE SAVING, OR LIFE SUSTAINING APPLICATIONS, NOR IN PRODUCTS OR SYSTEMS, WHERE FAILURE OR MALFUNCTION MAY RESULT IN PERSONAL INJURY, DEATH, OR SEVERE PROPERTY OR ENVIRONMENTAL DAMAGE.**

Resale of ST products with provisions different from the statements and/or technical features set forth in this document shall immediately void any warranty granted by ST for the ST product or service described herein and shall not create or extend in any manner whatsoever, any liability of ST.

ST and the ST logo are trademarks or registered trademarks of ST in various countries.

Information in this document supersedes and replaces all information previously supplied.

The ST logo is a registered trademark of STMicroelectronics. All other names are the property of their respective owners.

© 2006 STMicroelectronics - All rights reserved

STMicroelectronics group of companies

Australia - Belgium - Brazil - Canada - China - Czech Republic - Finland - France - Germany - Hong Kong - India - Israel - Italy - Japan - Malaysia - Malta - Morocco - Singapore - Spain - Sweden - Switzerland - United Kingdom - United States of America

[www.st.com](http://www.st.com)