



M24512-W M24512-R M24512-HR M24256-BW M24256-BR

512 Kbit and 256 Kbit serial I²C bus EEPROM
with three Chip Enable lines

Features

- Two-wire I²C serial interface supports the 1 MHz protocol
- Supply voltage ranges:
 - 1.8 V to 5.5 V (M24xxx-R)
 - 2.5 V to 5.5 V (M24xxx-W)
- Write Control input
- Byte and Page Write
- Random and sequential read modes
- Self-timed programming cycle
- Automatic address incrementing
- Enhanced ESD/latch-up protection
- More than 1 000 000 Write cycles
- More than 40-year data retention
- Packages
 - ECOPACK® (RoHS compliant)

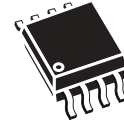

SO8 (MW)
208 mils width

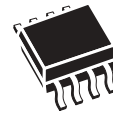

SO8 (MN)
150 mils width



TSSOP8 (DW)

Contents

1	Description	6
2	Signal description	8
2.1	Serial Clock (SCL)	8
2.2	Serial Data (SDA)	8
2.3	Chip Enable (E0, E1, E2)	8
2.4	Write Control (\overline{WC})	8
2.5	V_{SS} ground	9
2.6	Supply voltage (V_{CC})	9
2.6.1	Operating supply voltage V_{CC}	9
2.6.2	Power-up conditions	9
2.6.3	Device reset	9
2.6.4	Power-down conditions	9
3	Device operation	12
3.1	Start condition	12
3.2	Stop condition	12
3.3	Acknowledge bit (ACK)	12
3.4	Data input	12
3.5	Memory addressing	13
3.6	Write operations	15
3.7	Byte Write	15
3.8	Page Write	15
3.9	ECC (error correction code) and write cycling	16
3.10	Minimizing system delays by polling on ACK	17
3.11	Read operations	18
3.12	Random Address Read	18
3.13	Current Address Read	18
3.14	Sequential Read	18
3.15	Acknowledge in Read mode	19
4	Initial delivery state	20

5	Maximum rating	20
6	DC and AC parameters	21
7	Package mechanical	27
8	Part numbering	30
9	Revision history	32

List of tables

Table 1.	Signal names	6
Table 2.	Device select code	11
Table 3.	Most significant address byte	11
Table 4.	Least significant address byte	11
Table 5.	Operating modes	13
Table 6.	Absolute maximum ratings	20
Table 7.	Operating conditions (M24xxx-W)	21
Table 8.	Operating conditions (M24xxx-R and M24xxx-HR).	21
Table 9.	AC test measurement conditions	21
Table 10.	Input parameters.	22
Table 11.	DC characteristics (M24xxx-W)	22
Table 12.	DC characteristics (M24xxx-R and M24xxx-HR)	23
Table 13.	AC characteristics (M24xxx-W, M24xxx-R see Table 7 , Table 8 and Table 9).	24
Table 14.	1 MHz AC characteristics (M24xxx-HR, see Table 8 and Table 9).	25
Table 15.	SO8W – 8 lead plastic small outline, 208 mils body width, package mechanical data	27
Table 16.	SO8N – 8 lead plastic small outline, 150 mils body width, package mechanical data	28
Table 17.	TSSOP8 – 8 lead thin shrink small outline, package mechanical data.	29
Table 18.	Ordering information scheme	30
Table 19.	Available M24256-Bx products (package, voltage range, temperature grade).	31
Table 20.	Available M24512-x products (package, voltage range, temperature grade)	31
Table 21.	Document revision history	32

List of figures

Figure 1.	Logic diagram	6
Figure 2.	SO and TSSOP connections	7
Figure 3.	Device select code	8
Figure 4.	Maximum R_{bus} value versus bus parasitic capacitance (C_{bus}) for an I ² C bus at maximum frequency $f_C = 400$ kHz	10
Figure 5.	Maximum R_{bus} value versus bus parasitic capacitance (C_{bus}) for an I ² C bus at maximum frequency $f_C = 1$ MHz	10
Figure 6.	I ² C bus protocol	11
Figure 7.	Write mode sequences with $\overline{WC} = 1$ (data write inhibited)	14
Figure 8.	Write Mode sequences with $\overline{WC} = 0$ (data write enabled)	16
Figure 9.	Write cycle polling flowchart using ACK	17
Figure 10.	Read mode sequences.	19
Figure 11.	AC test measurement I/O waveform.	21
Figure 12.	AC waveforms	26
Figure 13.	SO8W – 8 lead plastic small outline, 208 mils body width, package outline.	27
Figure 14.	SO8N – 8 lead plastic small outline, 150 mils body width, package outline	28
Figure 15.	TSSOP8 – 8 lead thin shrink small outline, package outline	29

1 Description

The M24512-W, M24512-R, M24256-BW and M24256-BR devices are I²C-compatible electrically erasable programmable memories (EEPROM). They are organized as 64 Kb × 8 bits and 32 Kb × 8 bits, respectively.

I²C uses a two-wire serial interface, comprising a bidirectional data line and a clock line. The devices carry a built-in 4-bit Device Type Identifier code (1010) in accordance with the I²C bus definition.

The device behaves as a slave in the I²C protocol, with all memory operations synchronized by the serial clock. Read and Write operations are initiated by a Start condition, generated by the bus master. The Start condition is followed by a device select code and Read/Write bit (RW) (as described in [Table 2](#)), terminated by an acknowledge bit.

When writing data to the memory, the device inserts an acknowledge bit during the 9th bit time, following the bus master's 8-bit transmission. When data is read by the bus master, the bus master acknowledges the receipt of the data byte in the same way. Data transfers are terminated by a Stop condition after an Ack for Write, and after a NoAck for Read.

In order to meet environmental requirements, ST offers these devices in ECOPACK® packages.

ECOPACK® packages are Lead-free and RoHS compliant.

ECOPACK is an ST trademark. ECOPACK specifications are available at: www.st.com.

Figure 1. Logic diagram

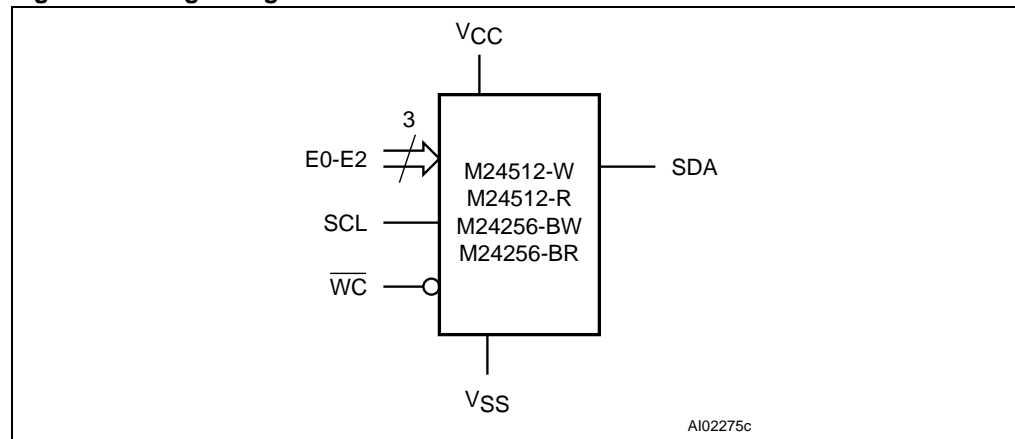
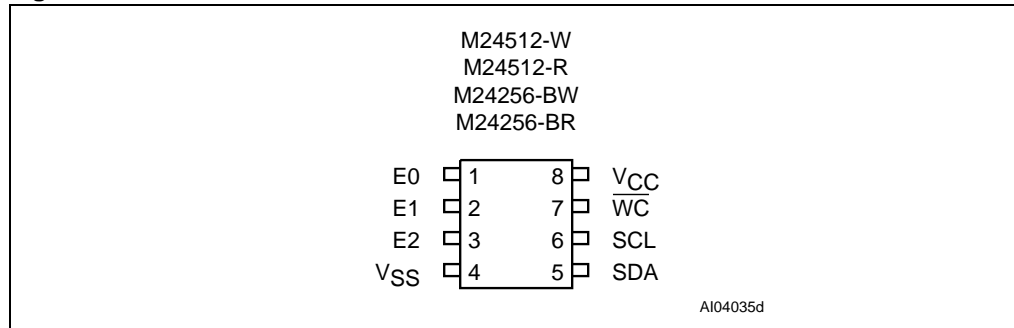

Table 1. Signal names

Signal name	Function	Direction
E0, E1, E2	Chip Enable	Inputs
SDA	Serial Data	I/O
SCL	Serial Clock	Input
\overline{WC}	Write Control	Input
V _{CC}	Supply voltage	
V _{SS}	Ground	

Figure 2. SO and TSSOP connections



1. See [Package mechanical](#) section for package dimensions, and how to identify pin-1.

2 Signal description

2.1 Serial Clock (SCL)

This input signal is used to strobe all data in and out of the device. In applications where this signal is used by slave devices to synchronize the bus to a slower clock, the bus master must have an open drain output, and a pull-up resistor must be connected from Serial Clock (SCL) to V_{CC} . (Figure 5. indicates how the value of the pull-up resistor can be calculated). In most applications, though, this method of synchronization is not employed, and so the pull-up resistor is not necessary, provided that the bus master has a push-pull (rather than open drain) output.

2.2 Serial Data (SDA)

This bidirectional signal is used to transfer data in or out of the device. It is an open drain output that may be wire-OR'ed with other open drain or open collector signals on the bus. A pull up resistor must be connected from Serial Data (SDA) to V_{CC} . (Figure 5. indicates how the value of the pull-up resistor can be calculated).

2.3 Chip Enable (E0, E1, E2)

These input signals are used to set the value that is to be looked for on the three least significant bits (b3, b2, b1) of the 7-bit device select code. These inputs must be tied to V_{CC} or V_{SS} , to establish the device select code. When not connected (left floating), these inputs are read as Low (0,0,0).

Figure 3. Device select code

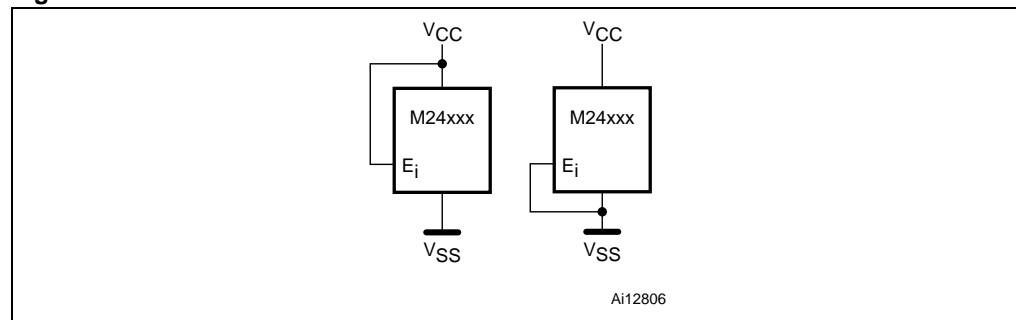

2.4 Write Control (\overline{WC})

This input signal is useful for protecting the entire contents of the memory from inadvertent write operations. Write operations are disabled to the entire memory array when Write Control (\overline{WC}) is driven High. When unconnected, the signal is internally read as V_{IL} , and Write operations are allowed.

When Write Control (\overline{WC}) is driven High, Device Select and Address bytes are acknowledged, Data bytes are not acknowledged.

2.5 V_{SS} ground

V_{SS} is the reference for the V_{CC} supply voltage.

2.6 Supply voltage (V_{CC})

2.6.1 Operating supply voltage V_{CC}

Prior to selecting the memory and issuing instructions to it, a valid and stable V_{CC} voltage within the specified [$V_{CC}(\min)$, $V_{CC}(\max)$] range must be applied (see [Table 7](#) and [Table 8](#)). In order to secure a stable DC supply voltage, it is recommended to decouple the V_{CC} line with a suitable capacitor (usually of the order of 10 nF to 100 nF) close to the V_{CC}/V_{SS} package pins.

This voltage must remain stable and valid until the end of the transmission of the instruction and, for a Write instruction, until the completion of the internal write cycle (t_W).

2.6.2 Power-up conditions

When the power supply is turned on, V_{CC} rises from V_{SS} to V_{CC} ; the V_{CC} rise time must not vary faster than 1 V/ μ s.

2.6.3 Device reset

In order to prevent inadvertent write operations during power-up, a power on reset (POR) circuit is included. At power-up (continuous rise of V_{CC}), the device does not respond to any instruction until the V_{CC} has reached the Power On Reset threshold voltage (this threshold is lower than the minimum V_{CC} operating voltage defined in [Table 7](#) and [Table 8](#)). Until V_{CC} passes over the POR threshold, the device is reset and in the Standby Power mode

In a similar way, during power-down (continuous decrease in V_{CC}), as soon as V_{CC} drops below the power on reset threshold voltage, the device is reset and stops responding to any instruction sent to it.

2.6.4 Power-down conditions

During power-down (where V_{CC} decreases continuously), the device must be in the Standby Power mode (mode reached after decoding a Stop condition, assuming that there is no internal Write cycle in progress).

Figure 4. Maximum R_{bus} value versus bus parasitic capacitance (C_{bus}) for an I²C bus at maximum frequency $f_C = 400$ kHz

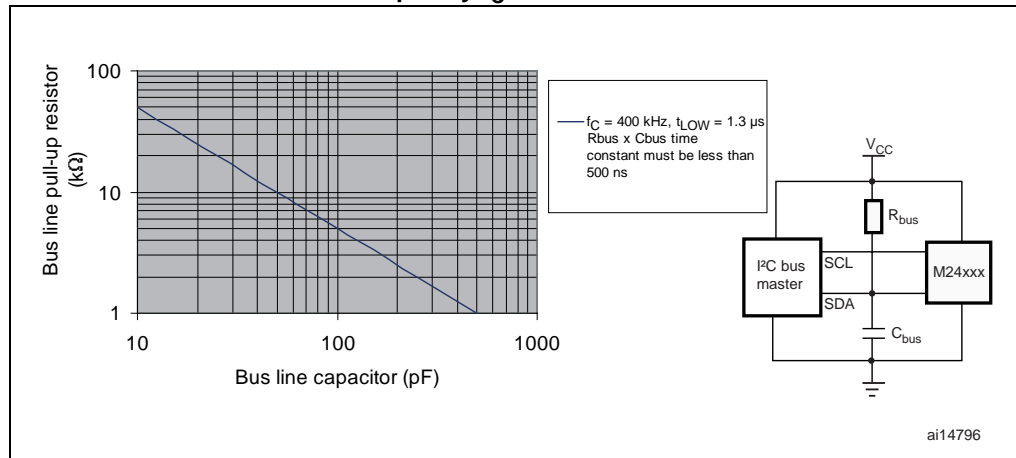

Figure 5. Maximum R_{bus} value versus bus parasitic capacitance (C_{bus}) for an I²C bus at maximum frequency $f_C = 1$ MHz

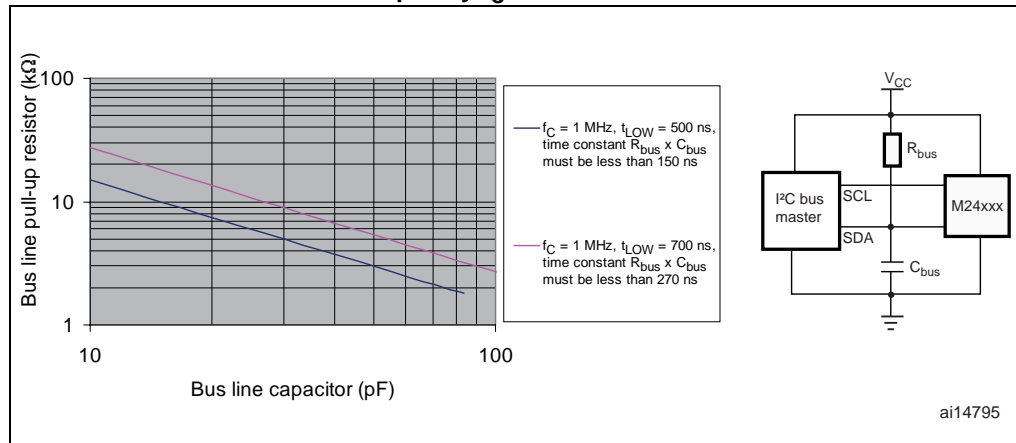

Figure 6. I²C bus protocol

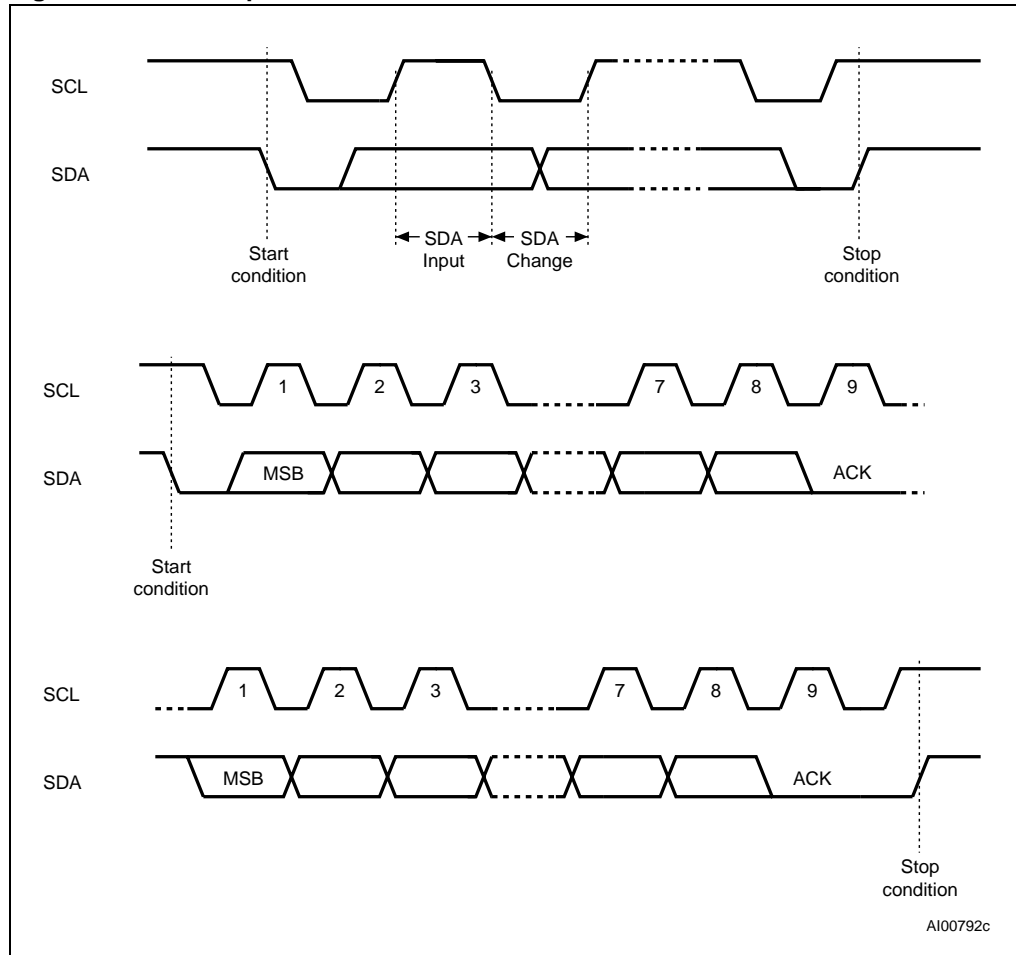

Table 2. Device select code

	Device type identifier ⁽¹⁾				Chip Enable address ⁽²⁾			R \bar{W}
	b7	b6	b5	b4	b3	b2	b1	b0
Device select code	1	0	1	0	E2	E1	E0	R \bar{W}

1. The most significant bit, b7, is sent first.

2. E0, E1 and E2 are compared against the respective external pins on the memory device.

Table 3. Most significant address byte

b15	b14	b13	b12	b11	b10	b9	b8
-----	-----	-----	-----	-----	-----	----	----

Table 4. Least significant address byte

b7	b6	b5	b4	b3	b2	b1	b0
----	----	----	----	----	----	----	----

3 Device operation

The device supports the I²C protocol. This is summarized in [Figure 6](#). Any device that sends data on to the bus is defined to be a transmitter, and any device that reads the data to be a receiver. The device that controls the data transfer is known as the bus master, and the other as the slave device. A data transfer can only be initiated by the bus master, which will also provide the serial clock for synchronization. The M24512-W, M24512-R, M24256-BW and M24256-BR devices are always slaves in all communications.

3.1 Start condition

Start is identified by a falling edge of Serial Data (SDA) while Serial Clock (SCL) is stable in the High state. A Start condition must precede any data transfer command. The device continuously monitors (except during a Write cycle) Serial Data (SDA) and Serial Clock (SCL) for a Start condition, and will not respond unless one is given.

3.2 Stop condition

Stop is identified by a rising edge of Serial Data (SDA) while Serial Clock (SCL) is stable and driven High. A Stop condition terminates communication between the device and the bus master. A Read command that is followed by NoAck can be followed by a Stop condition to force the device into the Standby mode. A Stop condition at the end of a Write command triggers the internal Write cycle.

3.3 Acknowledge bit (ACK)

The acknowledge bit is used to indicate a successful byte transfer. The bus transmitter, whether it be bus master or slave device, releases Serial Data (SDA) after sending eight bits of data. During the 9th clock pulse period, the receiver pulls Serial Data (SDA) Low to acknowledge the receipt of the eight data bits.

3.4 Data input

During data input, the device samples Serial Data (SDA) on the rising edge of Serial Clock (SCL). For correct device operation, Serial Data (SDA) must be stable during the rising edge of Serial Clock (SCL), and the Serial Data (SDA) signal must change *only* when Serial Clock (SCL) is driven Low.

3.5 Memory addressing

To start communication between the bus master and the slave device, the bus master must initiate a Start condition. Following this, the bus master sends the device select code, shown in [Table 2](#). (on Serial Data (SDA), most significant bit first).

The device select code consists of a 4-bit device type identifier, and a 3-bit Chip Enable "Address" (E2, E1, E0). To address the memory array, the 4-bit Device Type Identifier is 1010b.

Up to eight memory devices can be connected on a single I²C bus. Each one is given a unique 3-bit code on the Chip Enable (E0, E1, E2) inputs. When the device select code is received, the device only responds if the Chip Enable Address is the same as the value on the Chip Enable (E0, E1, E2) inputs.

The 8th bit is the Read/Write bit (\overline{RW}). This bit is set to 1 for Read and 0 for Write operations.

If a match occurs on the Device Select code, the corresponding device gives an acknowledgment on Serial Data (SDA) during the 9th bit time. If the device does not match the Device Select code, it deselects itself from the bus, and goes into Standby mode.

Table 5. Operating modes

Mode	\overline{RW} bit	$\overline{WC}^{(1)}$	Bytes	Initial sequence
Current Address Read	1	X	1	Start, Device Select, $\overline{RW} = 1$
Random Address Read	0	X	1	Start, Device Select, $\overline{RW} = 0$, Address
	1	X		re-Start, Device Select, $\overline{RW} = 1$
Sequential Read	1	X	≥ 1	Similar to Current or Random Address Read
Byte Write	0	V_{IL}	1	Start, Device Select, $\overline{RW} = 0$
Page Write	0	V_{IL}	≤ 128 for 512 Kbit devices	Start, Device Select, $\overline{RW} = 0$
			≤ 64 for 256 Kbit devices	

1. X = V_{IH} or V_{IL} .

Figure 7. Write mode sequences with $\overline{WC} = 1$ (data write inhibited)

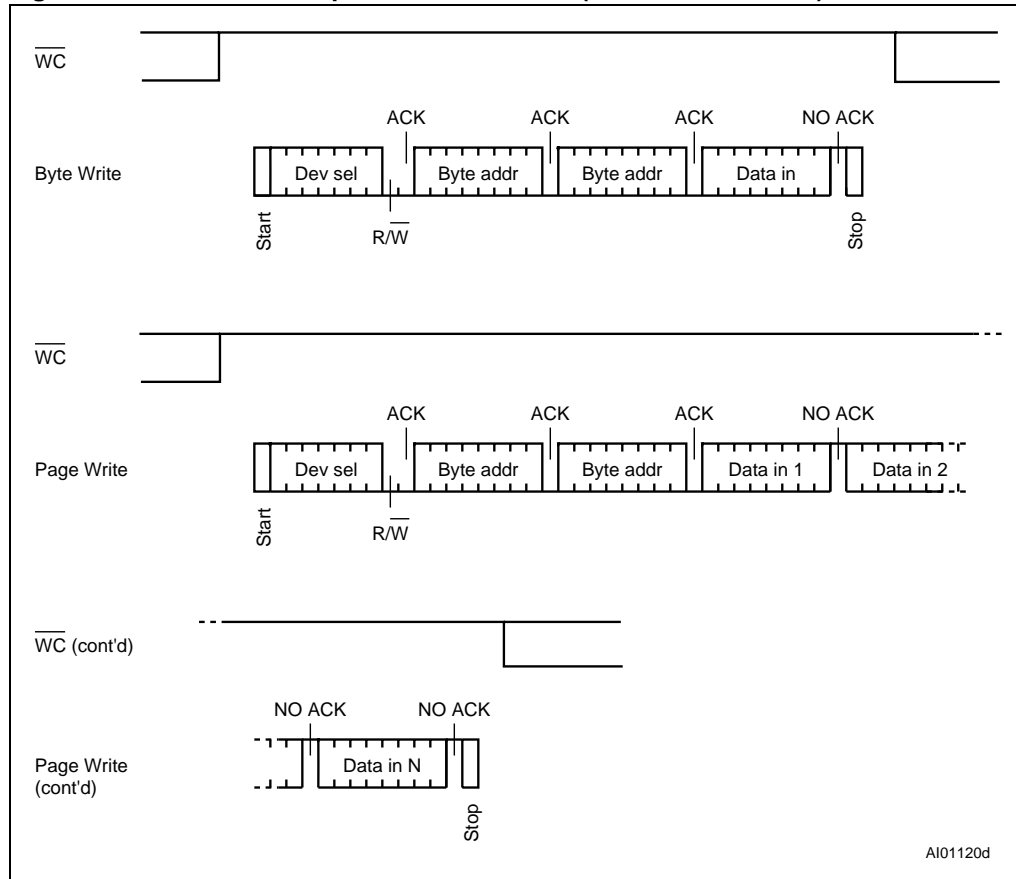

3.6 Write operations

Following a Start condition the bus master sends a device select code with the Read/Write bit (\overline{RW}) reset to 0. The device acknowledges this, as shown in [Figure 8](#), and waits for two address bytes. The device responds to each address byte with an acknowledge bit, and then waits for the data byte.

Writing to the memory may be inhibited if Write Control (\overline{WC}) is driven High. Any Write instruction with Write Control (\overline{WC}) driven High (during a period of time from the Start condition until the end of the two address bytes) will not modify the memory contents, and the accompanying data bytes are *not* acknowledged, as shown in [Figure 7](#).

Each data byte in the memory has a 16-bit (two byte wide) address. The most significant byte ([Table 3](#)) is sent first, followed by the least significant byte ([Table 4](#)). Bits b15 to b0 form the address of the byte in memory.

When the bus master generates a Stop condition immediately after the Ack bit (in the “10th bit” time slot), either at the end of a Byte Write or a Page Write, the internal Write cycle is triggered. A Stop condition at any other time slot does not trigger the internal Write cycle.

After the Stop condition, the delay t_{WV} , and the successful completion of a Write operation, the device's internal address counter is incremented automatically, to point to the next byte address after the last one that was modified.

During the internal Write cycle, Serial Data (SDA) is disabled internally, and the device does not respond to any requests.

3.7 Byte Write

After the Device Select code and the address bytes, the bus master sends one data byte. If the addressed location is Write-protected, by Write Control (\overline{WC}) being driven High, the device replies with NoAck, and the location is not modified. If, instead, the addressed location is not Write-protected, the device replies with Ack. The bus master terminates the transfer by generating a Stop condition, as shown in [Figure 8](#).

3.8 Page Write

The Page Write mode allows up to 64 bytes (for the M24256-BW and M24256-BR) or 128 bytes (for the M24512-W and M24512-R) to be written in a single Write cycle, provided that they are all located in the same 'row' in the memory: that is, the most significant memory address bits (b15-b6 for the M24256-BW and M24256-BR, and b15-b7 for the M24512-W and M24512-R) are the same. If more bytes are sent than will fit up to the end of the row, a condition known as 'roll-over' occurs. This should be avoided, as data starts to become overwritten in an implementation dependent way.

The bus master sends from 1 to 64 bytes (for the M24256-BW and M24256-BR) or from 1 to 128 bytes (for the M24512-W and M24512-R) of data, each of which is acknowledged by the device if Write Control (\overline{WC}) is Low. If Write Control (\overline{WC}) is High, the contents of the addressed memory location are not modified, and each data byte is followed by a NoAck. After each byte is transferred, the internal byte address counter (the 7 least significant address bits only) is incremented. The transfer is terminated by the bus master generating a Stop condition.

3.9 ECC (error correction code) and write cycling

The M24512-W, M24512-R, M24256-BW and M24256-BR devices offer an ECC (error correction code) logic which compares each 4-byte word with its six associated ECC EEPROM bits. As a result, if a single bit out of 4 bytes of data happens to be erroneous during a Read operation, the ECC detects it and replaces it by the correct value. The read reliability is therefore much improved by the use of this feature.

Note however that even if a single byte has to be written, 4 bytes are internally modified (plus the ECC bits), that is, the addressed byte is cycled together with the other three bytes making up the word. It is therefore recommended to write by word (4 bytes) in order to benefit from the larger amount of Write cycles.

The M24512-W, M24512-R, M24256-BW and M24256-BR devices are qualified at 1 million (1 000 000) Write cycles, using a cycling routine that writes to the device by multiples of 4-bytes.

Caution: Note that the M24512-W and M24512-R in SO8 Wide package (MW) are offered with either the previous die qualified at 100.000 Write cycles or the new die (qualified at 1 Million Write cycles). The two dice are distinguished by their respective process letter: "V" for the previous die and "A" for the new die. Please contact your nearest ST sales office for more information.

Figure 8. Write Mode sequences with $\overline{WC} = 0$ (data write enabled)

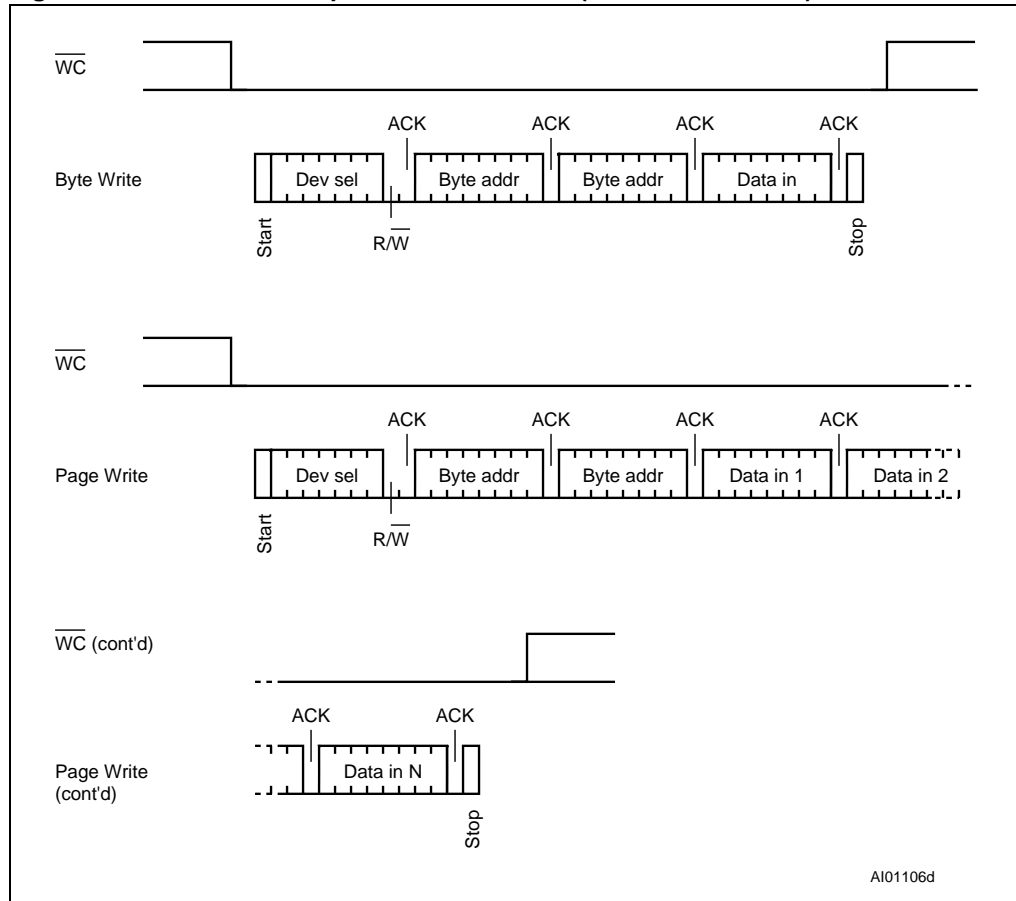

3.11 Read operations

Read operations are performed independently of the state of the Write Control (\overline{WC}) signal. After the successful completion of a Read operation, the device's internal address counter is incremented by one, to point to the next byte address.

3.12 Random Address Read

A dummy Write is first performed to load the address into this address counter (as shown in [Figure 10](#).) but *without* sending a Stop condition. Then, the bus master sends another Start condition, and repeats the device select code, with the Read/Write bit (\overline{RW}) set to 1. The device acknowledges this, and outputs the contents of the addressed byte. The bus master must *not* acknowledge the byte, and terminates the transfer with a Stop condition.

3.13 Current Address Read

For the Current Address Read operation, following a Start condition, the bus master only sends a device select code with the Read/Write bit (\overline{RW}) set to 1. The device acknowledges this, and outputs the byte addressed by the internal address counter. The counter is then incremented. The bus master terminates the transfer with a Stop condition, as shown in [Figure 10](#)., *without* acknowledging the byte.

3.14 Sequential Read

This operation can be used after a Current Address Read or a Random Address Read. The bus master *does* acknowledge the data byte output, and sends additional clock pulses so that the device continues to output the next byte in sequence. To terminate the stream of bytes, the bus master must *not* acknowledge the last byte, and *must* generate a Stop condition, as shown in [Figure 10](#).

The output data comes from consecutive addresses, with the internal address counter automatically incremented after each byte output. After the last memory address, the address counter 'rolls-over', and the device continues to output data from memory address 00h.

Figure 10. Read mode sequences

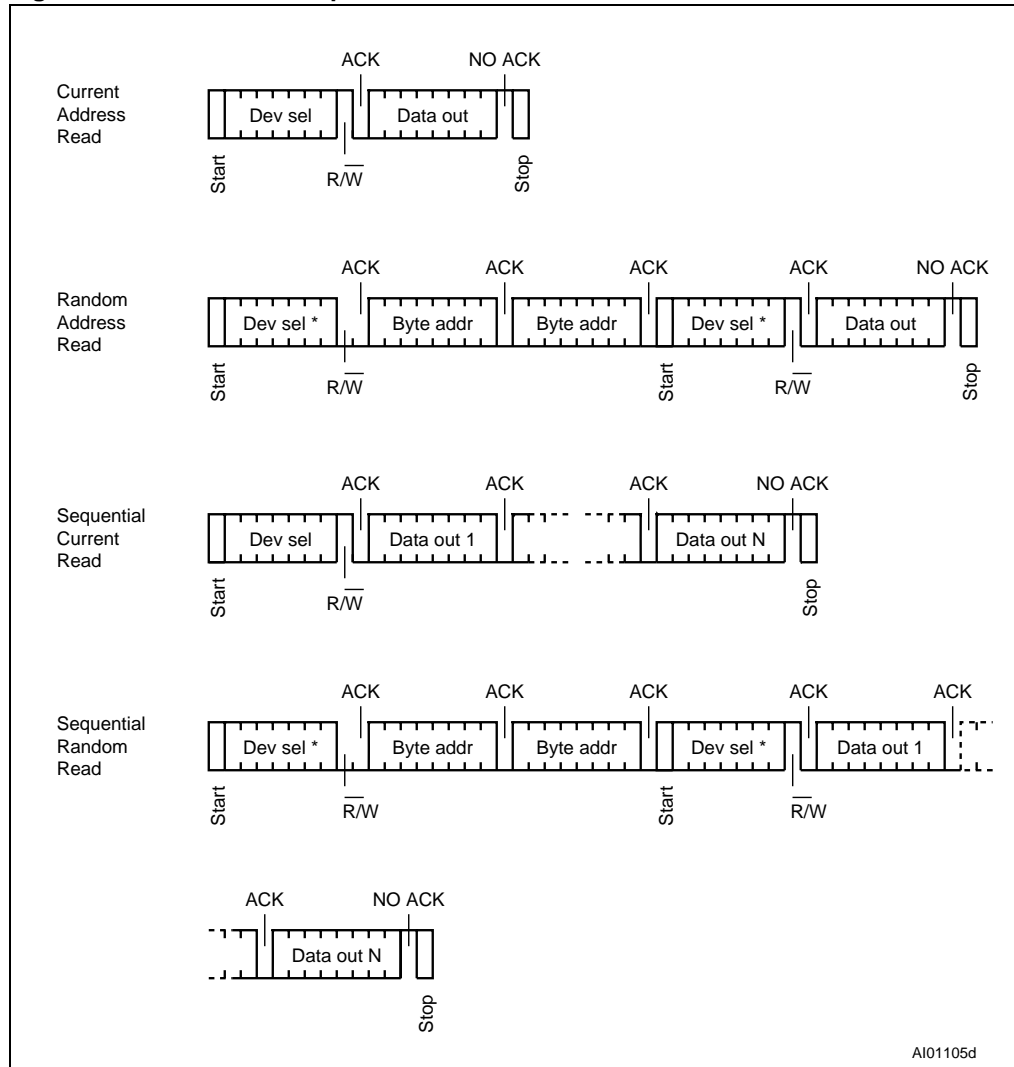

1. The seven most significant bits of the device select code of a Random Read (in the 1st and 4th bytes) must be identical.

3.15 Acknowledge in Read mode

For all Read commands, the device waits, after each byte read, for an acknowledgment during the 9th bit time. If the bus master does not drive Serial Data (SDA) Low during this time, the device terminates the data transfer and switches to its Standby mode.

4 Initial delivery state

The device is delivered with all bits in the memory array set to 1 (each byte contains FFh).

5 Maximum rating

Stressing the device outside the ratings listed in [Table 6](#) may cause permanent damage to the device. These are stress ratings only, and operation of the device at these, or any other conditions outside those indicated in the operating sections of this specification, is not implied. Exposure to absolute maximum rating conditions for extended periods may affect device reliability. Refer also to the STMicroelectronics SURE Program and other relevant quality documents.

Table 6. Absolute maximum ratings

Symbol	Parameter	Min.	Max.	Unit
T_A	Ambient operating temperature	-40	130	°C
T_{STG}	Storage temperature	-65	150	°C
T_{LEAD}	Lead temperature during soldering	See note ⁽¹⁾		°C
V_{IO}	Input or output range	-0.50	$V_{CC} + 0.6$	V
V_{CC}	Supply voltage	-0.50	6.5	V
V_{ESD}	Electrostatic discharge voltage (human body model) ⁽²⁾	-4000	4000	V

1. Compliant with JEDEC Std J-STD-020D (for small body, Sn-Pb or Pb assembly), the ST ECOPACK[®] 7191395 specification, and the European directive on the restriction of the use of certain hazardous substances in electrical and electronic equipment (RoHS) 2002/95/EC.
2. AEC-Q100-002 (compliant with JEDEC Std JESD22-A114D, C1 = 100 pF, R1 = 1500 Ω , R2 = 500 Ω)

6 DC and AC parameters

This section summarizes the operating and measurement conditions, and the dc and ac characteristics of the device. The parameters in the DC and AC characteristic tables that follow are derived from tests performed under the measurement conditions summarized in the relevant tables. Designers should check that the operating conditions in their circuit match the measurement conditions when relying on the quoted parameters.

Table 7. Operating conditions (M24xxx-W)

Symbol	Parameter	Min.	Max.	Unit
V_{CC}	Supply voltage	2.5	5.5	V
T_A	Ambient operating temperature	-40	85	°C

Table 8. Operating conditions (M24xxx-R and M24xxx-HR)

Symbol	Parameter	Min.	Max.	Unit
V_{CC}	Supply voltage	1.8	5.5	V
T_A	Ambient operating temperature	-40	85	°C

Table 9. AC test measurement conditions

Symbol	Parameter	Min.	Max.	Unit
C_L	Load capacitance	100		pF
	Input rise and fall times		50	ns
	Input levels	0.2 V_{CC} to 0.8 V_{CC}		V
	Input and output timing reference levels	0.3 V_{CC} to 0.7 V_{CC}		V

Figure 11. AC test measurement I/O waveform

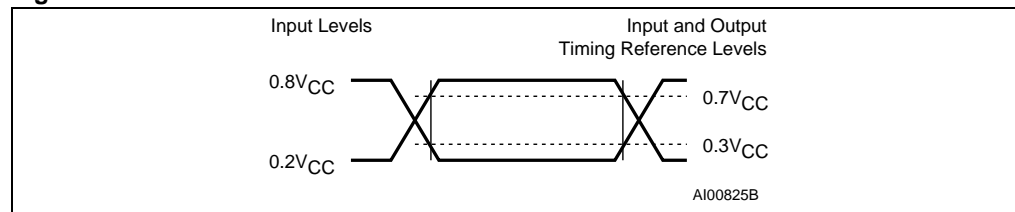

Table 10. Input parameters

Symbol	Parameter ⁽¹⁾	Test condition	Min.	Max.	Unit
C_{IN}	Input capacitance (SDA)			8	pF
C_{IN}	Input capacitance (other pins)			6	pF
$Z_L^{(2)}$	Input impedance (E2, E1, E0, \overline{WC})	$V_{IN} < 0.3V_{CC}$	30		k Ω
$Z_H^{(2)}$	Input impedance (E2, E1, E0, \overline{WC})	$V_{IN} > 0.7V_{CC}$	500		k Ω

1. Sampled only, not 100% tested.

2. E2,E1,E0: Input impedance when the memory is selected (after a Start condition).

Table 11. DC characteristics (M24xxx-W)

Symbol	Parameter	Test conditions (see Table 7 and Table 9)	Min.	Max.	Unit
I_{LI}	Input leakage current (SCL, SDA, E0, E1, E2)	$V_{IN} = V_{SS}$ or V_{CC} device in Standby mode		± 2	μA
I_{LO}	Output leakage current	SDA in Hi-Z, external voltage applied on SDA: V_{SS} or V_{CC}		± 2	μA
I_{CC}	Supply current (Read)	$V_{CC} = 2.5V$, $f_c=400$ kHz (rise/fall time < 50 ns)		1	mA
		$V_{CC} = 5.5V$, $f_c=400$ kHz (rise/fall time < 50 ns)		2	mA
I_{CC0}	Supply current (Write)	During t_W , $2.5V < V_{CC} < 5.5V$		5 ⁽¹⁾	mA
I_{CC1}	Standby supply current	$V_{IN} = V_{SS}$ or V_{CC} , $V_{CC} = 2.5V$		2	μA
		$V_{IN} = V_{SS}$ or V_{CC} , $V_{CC} = 5.5V$		5	μA
V_{IL}	Input low voltage (SCL, SDA, \overline{WC})		-0.45	$0.3V_{CC}$	V
V_{IH}	Input high voltage (SCL, SDA, \overline{WC})		$0.7V_{CC}$	$V_{CC}+0.6$	V
V_{OL}	Output low voltage	$I_{OL} = 2.1$ mA, $V_{CC} = 2.5V$		0.4	V

1. Characterized value, not tested in production.

Table 12. DC characteristics (M24xxx-R and M24xxx-HR)

Symbol	Parameter	Test condition (in addition to those in Table 8)	Min.	Max.	Unit
I_{LI}	Input leakage current (E1, E2, SCL, SDA)	$V_{IN} = V_{SS}$ or V_{CC} device in Standby mode		± 2	μA
I_{LO}	Output leakage current	SDA in Hi-Z, external voltage applied on SDA: V_{SS} or V_{CC}		± 2	μA
I_{CC}	Supply current (Read)	$V_{CC} = 1.8 V$, $f_c = 400 kHz$ (rise/fall time < 50 ns)		0.8	mA
		$V_{CC} = 2.5 V$, $f_c = 400 kHz$ (rise/fall time < 50 ns)		1	mA
		$V_{CC} = 5.0 V$, $f_c = 400 kHz$ (rise/fall time < 50 ns)		2	mA
		$1.8 V < V_{CC} < 5.5 V$, $f_c = 1 MHz^{(1)}$ (rise/fall time < 50 ns)		2.5	mA
I_{CC0}	Supply current (Write)	During t_W , $1.8V < V_{CC} < 5.5V$		$5^{(2)}$	mA
I_{CC1}	Standby supply current	$V_{IN} = V_{SS}$ or V_{CC} , $V_{CC} = 1.8 V$		1	μA
		$V_{IN} = V_{SS}$ or V_{CC} , $V_{CC} = 2.5 V$		2	μA
		$V_{IN} = V_{SS}$ or V_{CC} , $V_{CC} = 5.5 V$		3	μA
V_{IL}	Input low voltage (SCL, SDA, \overline{WC})	$1.8 V \leq V_{CC} < 2.5 V$	-0.45	$0.25 V_{CC}$	V
		$2.5 V \leq V_{CC} \leq 5.5 V$	-0.45	$0.3 V_{CC}$	
V_{IH}	Input high voltage (SCL, SDA, \overline{WC})	$1.8 V \leq V_{CC} < 2.5 V$	$0.75V_{CC}$	$V_{CC}+1$	V
		$2.5 V \leq V_{CC} \leq 5.5 V$	$0.7V_{CC}$	$V_{CC}+1$	
V_{OL}	Output low voltage	$I_{OL} = 1 mA$, $V_{CC} = 1.8 V$		0.2	V
		$I_{OL} = 2.1 mA$, $V_{CC} = 2.5 V$		0.4	V
		$I_{OL} = 3.0 mA$, $V_{CC} = 5.5 V$		0.4	V

1. Only for M24512-HR6.

2. Characterized value, not tested in production.

Table 13. AC characteristics (M24xxx-W, M24xxx-R see [Table 7](#), [Table 8](#) and [Table 9](#))

Symbol	Alt.	Parameter	Min.	Max.	Unit
f_C	f_{SCL}	Clock frequency		400	kHz
t_{CHCL}	t_{HIGH}	Clock pulse width high	600		ns
t_{CLCH}	t_{LOW}	Clock pulse width low	1300		ns
$t_{DL1DL2}^{(1)}$	t_F	SDA (out) fall time	20	100	ns
$t_{XH1XH2}^{(2)}$	t_R	Input signal rise time	20	300	ns
$t_{XL1XL2}^{(2)}$	t_F	Input signal fall time	20	300	ns
t_{DXCX}	$t_{SU:DAT}$	Data in set up time	100		ns
t_{CLDX}	$t_{HD:DAT}$	Data in hold time	0		ns
t_{CLQX}	t_{DH}	Data out hold time	200		ns
$t_{CLQV}^{(3)}$	t_{AA}	Clock low to next data valid (access time)	200	900	ns
$t_{CHDX}^{(4)}$	$t_{SU:STA}$	Start condition set up time	600		ns
t_{DLCL}	$t_{HD:STA}$	Start condition hold time	600		ns
t_{CHDH}	$t_{SU:STO}$	Stop condition set up time	600		ns
t_{DHDL}	t_{BUF}	Time between Stop condition and next Start condition	1300		ns
t_W	t_{WR}	Write time		5	ms
t_{NS}		Pulse width ignored (input filter on SCL and SDA) - single glitch		100	ns

1. Sampled only, not 100% tested.
2. Values recommended by I²C-bus/Fast-Mode specification.
3. To avoid spurious Start and Stop conditions, a minimum delay is placed between SCL=1 and the falling or rising edge of SDA.
4. For a re-Start condition, or following a Write cycle.

Table 14. 1 MHz AC characteristics (M24xxx-HR, see [Table 8](#) and [Table 9](#))

Test conditions specified in Table 8					
Symbol	Alt.	Parameter	Min.	Max.	Unit
f_C	f_{SCL}	Clock frequency	0	1	MHz
t_{CHCL}	t_{HIGH}	Clock pulse width high	300	-	ns
t_{CLCH}	t_{LOW}	Clock pulse width low	400	-	ns
$t_{XH1XH2}^{(1)}$	t_R	Input signal rise time	20	300	ns
$t_{XL1XL2}^{(1)}$	t_F	Input signal fall time	20	300	ns
$t_{DL1DL2}^{(2)}$	t_F	SDA (out) fall time	20	100	ns
t_{DXCX}	$t_{SU:DAT}$	Data in setup time	80	-	ns
t_{CLDX}	$t_{HD:DAT}$	Data in hold time	0	-	ns
t_{CLQX}	t_{DH}	Data out hold time	50	-	ns
$t_{CLQV}^{(3)(4)}$	t_{AA}	Clock low to next data valid (access time)	50	500	ns
$t_{CHDX}^{(5)}$	$t_{SU:STA}$	Start condition setup time	250	-	ns
t_{DLCL}	$t_{HD:STA}$	Start condition hold time	250	-	ns
t_{CHDH}	$t_{SU:STO}$	Stop condition setup time	250	-	ns
t_{DHDL}	t_{BUF}	Time between Stop condition and next Start condition	500	-	ns
t_W	t_{WR}	Write time	-	5	ms
$t_{NS}^{(2)}$		Pulse width ignored (input filter on SCL and SDA)	-	50	ns

1. Values recommended by the I²C-bus Fast-Mode specification.
2. Characterized only, not tested in production.
3. To avoid spurious Start and Stop conditions, a minimum delay is placed between SCL=1 and the falling or rising edge of SDA.
4. t_{CLQV} is the time (from the falling edge of SCL) required by the SDA bus line to reach 0.8V_{CC}, assuming that the R_{bus} × C_{bus} time constant is less than 150 ns (as specified in [Figure 4](#)).
5. For a reStart condition, or following a Write cycle.

Figure 12. AC waveforms

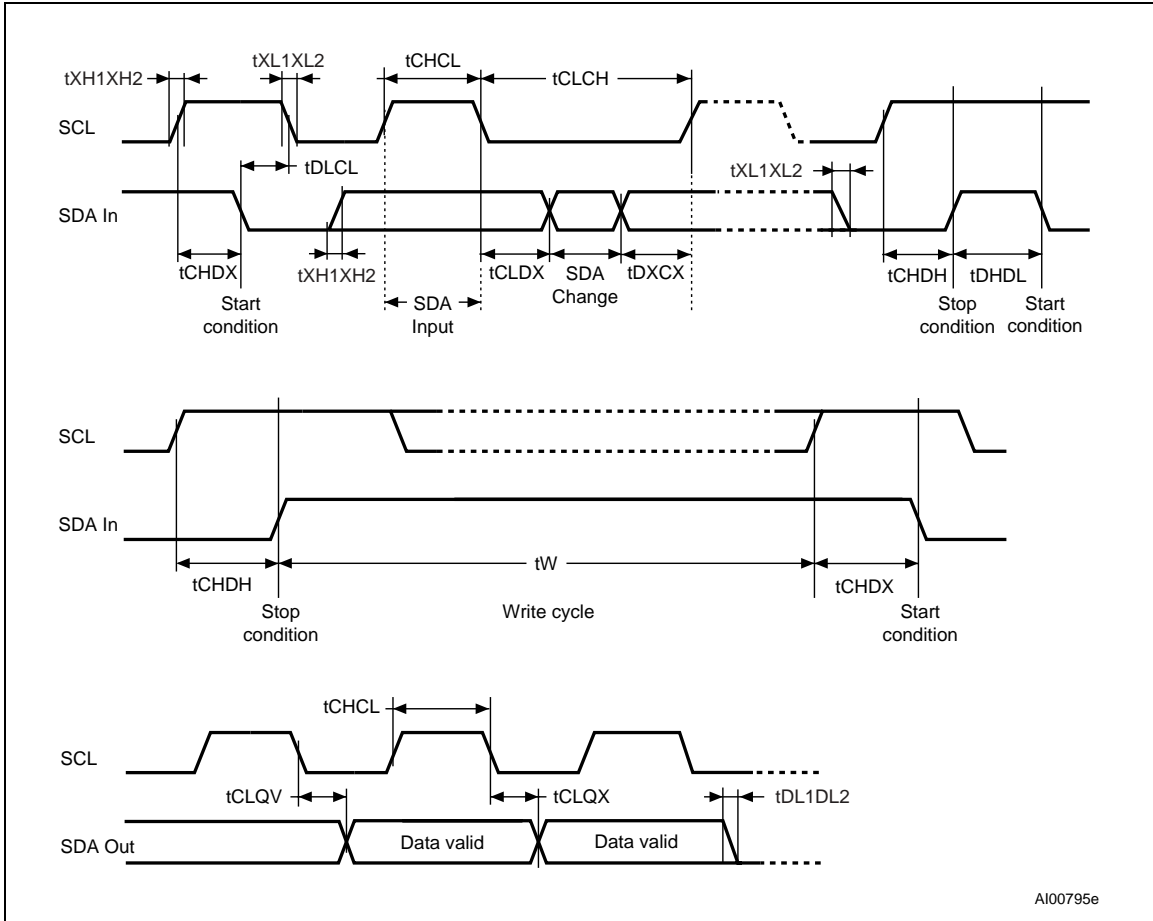

7 Package mechanical

Figure 13. SO8W – 8 lead plastic small outline, 208 mils body width, package outline

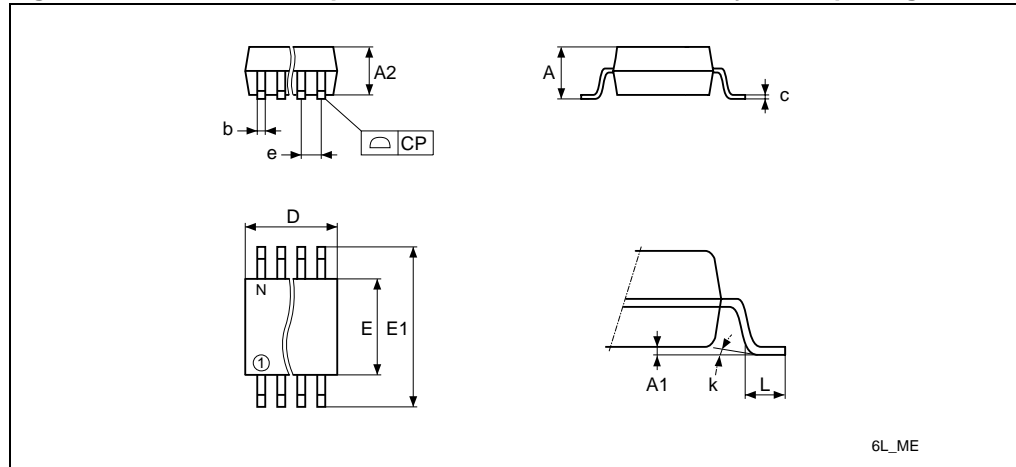

1. Drawing is not to scale.

Table 15. SO8W – 8 lead plastic small outline, 208 mils body width, package mechanical data

Symbol	millimeters			inches ⁽¹⁾		
	Typ	Min	Max	Typ	Min	Max
A			2.5			0.0984
A1		0	0.25		0	0.0098
A2		1.51	2		0.0594	0.0787
b	0.4	0.35	0.51	0.0157	0.0138	0.0201
c	0.2	0.1	0.35	0.0079	0.0039	0.0138
CP			0.1			0.0039
D			6.05			0.2382
E		5.02	6.22		0.1976	0.2449
E1		7.62	8.89		0.3	0.35
e	1.27	-	-	0.05	-	-
k		0°	10°		0°	10°
L		0.5	0.8		0.0197	0.0315
N (number of pins)	8			8		

1. Values in inches are converted from mm and rounded to 4 decimal digits.

Figure 14. SO8N – 8 lead plastic small outline, 150 mils body width, package outline

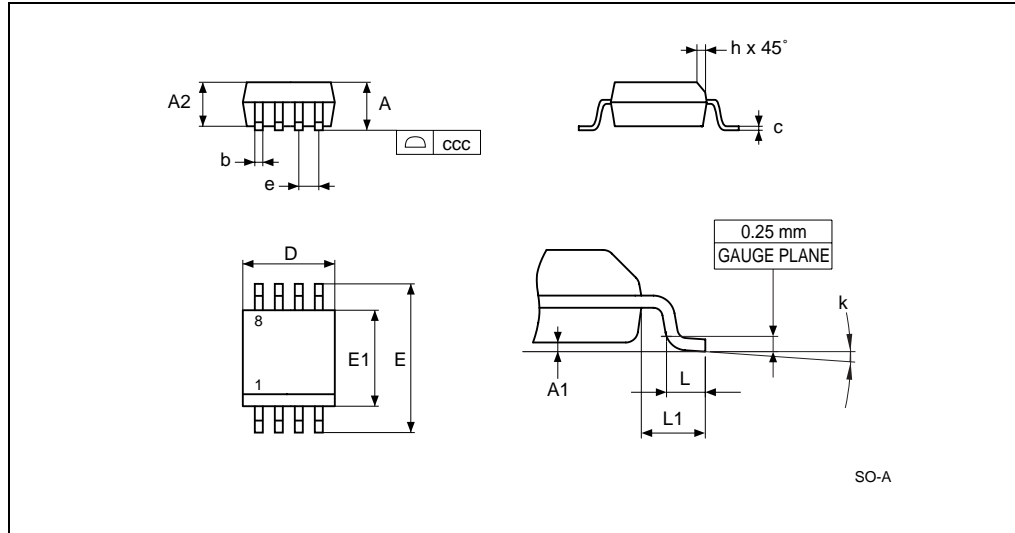

1. Drawing is not to scale.

Table 16. SO8N – 8 lead plastic small outline, 150 mils body width, package mechanical data

Symbol	millimeters			inches ⁽¹⁾		
	Typ	Min	Max	Typ	Min	Max
A			1.75			0.0689
A1		0.1	0.25		0.0039	0.0098
A2		1.25			0.0492	
b		0.28	0.48		0.011	0.0189
c		0.17	0.23		0.0067	0.0091
ccc			0.1			0.0039
D	4.9	4.8	5	0.1929	0.189	0.1969
E	6	5.8	6.2	0.2362	0.2283	0.2441
E1	3.9	3.8	4	0.1535	0.1496	0.1575
e	1.27	-	-	0.05	-	-
h		0.25	0.5		0.0098	0.0197
k		0°	8°		0°	8°
L		0.4	1.27		0.0157	0.05
L1	1.04			0.0409		

1. Values in inches are converted from mm and rounded to 4 decimal digits.

Figure 15. TSSOP8 – 8 lead thin shrink small outline, package outline

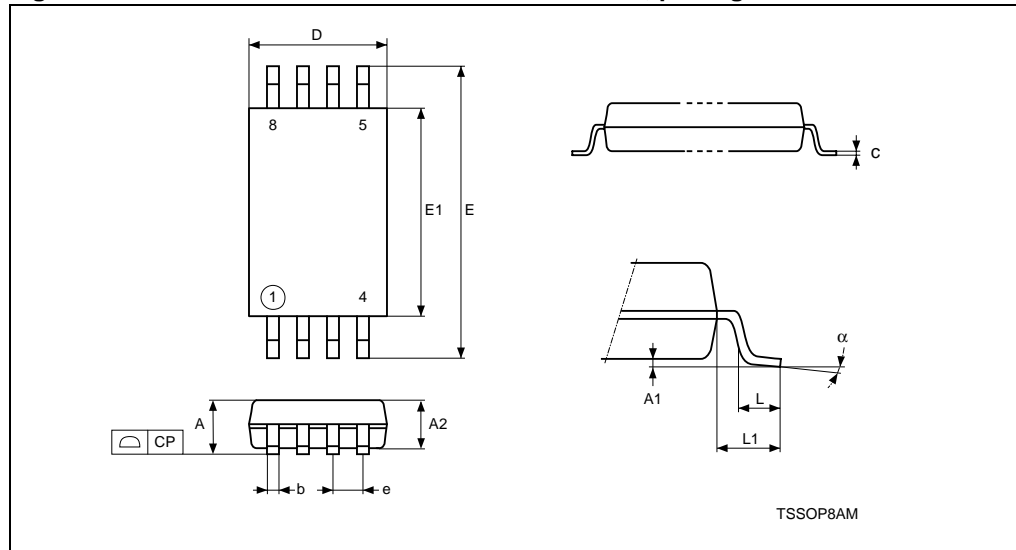

1. Drawing is not to scale.

Table 17. TSSOP8 – 8 lead thin shrink small outline, package mechanical data

Symbol	millimeters			inches ⁽¹⁾		
	Typ	Min	Max	Typ	Min	Max
A			1.200			0.0472
A1		0.050	0.150		0.0020	0.0059
A2	1.000	0.800	1.050	0.0394	0.0315	0.0413
b		0.190	0.300		0.0075	0.0118
c		0.090	0.200		0.0035	0.0079
CP			0.100			0.0039
D	3.000	2.900	3.100	0.1181	0.1142	0.1220
e	0.650	–	–	0.0256	–	–
E	6.400	6.200	6.600	0.2520	0.2441	0.2598
E1	4.400	4.300	4.500	0.1732	0.1693	0.1772
L	0.600	0.450	0.750	0.0236	0.0177	0.0295
L1	1.000			0.0394		
α		0°	8°		0°	8°
N		8			8	

1. Values in inches are converted from mm and rounded to 4 decimal digits.

8 Part numbering

Table 18. Ordering information scheme

Example:	M24512-	H	W	MW	6	T	P
Device type M24 = I ² C serial access EEPROM							
Device function 512- = 512 Kbit (64 Kb × 8) 256-B = 256 Kbit (32 Kb × 8)							
Clock frequency Blank: f _C max = 400 kHz H: f _C max = 1 MHz							
Operating voltage W = V _{CC} = 2.5 to 5.5 V R = V _{CC} = 1.8 to 5.5 V							
Package MW = SO8 (208 mils width) MN = SO8 (150 mils body width) DW = TSSOP8							
Device grade 6 = Industrial temperature range, -40 to 85 °C. Device tested with standard test flow							
Option blank = standard packing T = tape and reel packing							
Plating technology P or G = ECOPACK® (RoHS compliant)							

For a list of available options (speed, package, etc.) or for further information on any aspect of this device, please contact your nearest ST sales office.

The category of second-level interconnect is marked on the package and on the inner box label, in compliance with JEDEC standard JESD97. The maximum ratings related to soldering conditions are also marked on the inner box label.

Table 19. Available M24256-Bx products (package, voltage range, temperature grade)

Package	M24256-BW 2.5 V to 5.5 V	M24256-BR 1.8 V to 5.5 V
SO8N (MN)	Range 6	Range 6
SO8W (MW)	Range 6	-
TSSOP (DW)	Range 6	Range 6

Table 20. Available M24512-x products (package, voltage range, temperature grade)

Package	M24512-W 2.5 V to 5.5 V	M24512-R 1.8 V to 5.5 V	M24512-HR 1.8 V to 5.5 V
SO8N (MN)	Range 6	Range 6	Range 6
SO8W (MW)	Range 6	-	-
TSSOP (DW)	Range 6	Range 6	-

9 Revision history

Table 21. Document revision history

Date	Revision	Changes
29-Jan-2001	1.1	Lead Soldering Temperature in the Absolute Maximum Ratings table amended Write Cycle Polling Flow Chart using ACK illustration updated LGA8 and SO8(wide) packages added References to PSDIP8 changed to PDIP8, and Package Mechanical data updated
10-Apr-2001	1.2	LGA8 Package Mechanical data and illustration updated SO16 package removed
16-Jul-2001	1.3	LGA8 Package given the designator "LA"
02-Oct-2001	1.4	LGA8 Package mechanical data updated
13-Dec-2001	1.5	Document becomes Preliminary Data Test conditions for ILI, ILO, ZL and ZH made more precise VIL and VIH values unified. tNS value changed
12-Jun-2001	1.6	Document promoted to Full Datasheet
22-Oct-2003	2.0	Table of contents, and Pb-free options added. Minor wording changes in Summary Description, Power-On Reset, Memory Addressing, Write Operations, Read Operations. $V_{IL}(\min)$ improved to $-0.45V$.
02-Sep-2004	3.0	LGA8 package is Not for New Design. 5V and -S supply ranges, and Device Grade 5 removed. Absolute Maximum Ratings for $V_{IO}(\min)$ and $V_{CC}(\min)$ changed. Soldering temperature information clarified for RoHS compliant devices. Device grade information clarified. AEC-Q100-002 compliance. V_{IL} specification unified for SDA, SCL and WC
22-Feb-2005	4.0	<i>Initial delivery state</i> is FFh (not necessarily the same as Erased). LGA package removed, TSSOP8 and SO8N packages added (see Package mechanical section and Table 18. , Ordering information scheme). Voltage range R (1.8V to 5.5V) also offered. Minor wording changes. Z_L Test Conditions modified in Table 10. , Input parameters and Note 2. added. I_{CC} and I_{CC1} values for $V_{CC} = 5.5V$ added to Table 11. , DC characteristics (M24xxx-W). Note added to Table 11. , DC characteristics (M24xxx-W). <i>Power On Reset</i> paragraph specified. t_W max value modified in Table 13. , AC characteristics (M24xxx-W, M24xxx-R see Table 7 , Table 8 and Table 9) and note 4 added. Plating technology changed in Table 18. , Ordering information scheme. Resistance and capacitance renamed in Figure 5. , Maximum Rbus value versus bus parasitic capacitance (Cbus) for an I2C bus at maximum frequency $f_C = 1$ MHz.

Table 21. Document revision history (continued)

Date	Revision	Changes
05-May-2006	5	<p><i>Power On Reset</i> paragraph replaced by <i>Section 2.6: Supply voltage (VCC)</i>. <i>Figure 3: Device select code</i> added.</p> <p><i>ECC (error correction code) and write cycling</i> added and specified at 1 Million cycles.</p> <p>I_{CC0} added and I_{CC1} specified over the whole voltage range in <i>Table 11</i> and <i>Table 12</i>.</p> <p>PDIP8 package removed. Packages are ECOPACK® compliant. Small text changes.</p>
16-Oct-2006	6	<p>M24256-BW and M24256-BR part numbers added.</p> <p><i>Section 3.9: ECC (error correction code) and write cycling</i> updated.</p> <p>I_{CC} and I_{CC1} modified in <i>Table 12: DC characteristics (M24xxx-R and M24xxx-HR)</i>.</p> <p>t_W modified in <i>Table 13: AC characteristics (M24xxx-W, M24xxx-R see Table 7, Table 8 and Table 9)</i>.</p> <p>SO8Narrow package specifications updated (see <i>Table 16</i> and <i>Figure 14</i>). Blank option removed from below <i>Plating technology</i> in <i>Table 18: Ordering information scheme</i>.</p>
02-Jul-2007	7	<p><i>Section 2.6: Supply voltage (VCC)</i> modified.</p> <p><i>Section 3.9: ECC (error correction code) and write cycling</i> modified.</p> <p>JEDEC standard and European directive references corrected below <i>Table 6: Absolute maximum ratings</i>.</p> <p>Rise/fall time conditions modified for I_{CC} and V_{IH} max modified in <i>Table 11: DC characteristics (M24xxx-W)</i> and <i>Table 12: DC characteristics (M24xxx-R and M24xxx-HR)</i></p> <p>Note 1 removed from <i>Table 11: DC characteristics (M24xxx-W)</i>.</p> <p>SO8W package specifications modified in <i>Section 7: Package mechanical</i>.</p> <p><i>Table 19: Available M24256-Bx products (package, voltage range, temperature grade)</i> and <i>Table 20: Available M24512-x products (package, voltage range, temperature grade)</i> added.</p>
16-Oct-2007	8	<p><i>Section 2.5: VSS ground</i> added. Small text changes.</p> <p>V_{IO} max changed and <i>Note 1</i> updated to latest standard revision in <i>Table 6: Absolute maximum ratings</i>.</p> <p>Note removed from <i>Table 10: Input parameters</i>.</p> <p>V_{IH} min and V_{IL} max modified in <i>Table 12: DC characteristics (M24xxx-R and M24xxx-HR)</i>.</p> <p>Removed t_{CH1CH2}, t_{CL1CL2} and t_{DH1DH2}, and added t_{XL1XL2}, t_{DL1DL2} and <i>Note 2</i> in <i>Table 13: AC characteristics (M24xxx-W, M24xxx-R see Table 7, Table 8 and Table 9)</i>.</p> <p>t_{XH1XH2}, t_{XL1XL2} and <i>Note 2</i> added to <i>Table 14: 1 MHz AC characteristics (M24xxx-HR, see Table 8 and Table 9)</i>.</p> <p><i>Figure 12: AC waveforms</i> modified.</p> <p>Package mechanical data inch values calculated from mm and rounded to 4 decimal digits (see <i>Section 7: Package mechanical</i>).</p>

Table 21. Document revision history (continued)

Date	Revision	Changes
14-Dec-2007	9	<p>1 MHz frequency introduced (M24512-HR root part number).</p> <p><i>Section 2.6.3: Device reset</i> modified.</p> <p><i>Figure 4: Maximum Rbus value versus bus parasitic capacitance (Cbus) for an I2C bus at maximum frequency fC = 400 kHz</i> modified, <i>Figure 5: Maximum Rbus value versus bus parasitic capacitance (Cbus) for an I2C bus at maximum frequency fC = 1 MHz</i> added.</p> <p>t_{NS} moved from <i>Table 10</i> to <i>Table 13</i>. I_{LO} test conditions modified in <i>Table 11</i>.</p> <p><i>Table 12: DC characteristics (M24xxx-R and M24xxx-HR)</i> and <i>Table 14: 1 MHz AC characteristics (M24xxx-HR, see Table 8 and Table 9)</i> modified.</p> <p>Small text changes.</p>

Please Read Carefully:

Information in this document is provided solely in connection with ST products. STMicroelectronics NV and its subsidiaries ("ST") reserve the right to make changes, corrections, modifications or improvements, to this document, and the products and services described herein at any time, without notice.

All ST products are sold pursuant to ST's terms and conditions of sale.

Purchasers are solely responsible for the choice, selection and use of the ST products and services described herein, and ST assumes no liability whatsoever relating to the choice, selection or use of the ST products and services described herein.

No license, express or implied, by estoppel or otherwise, to any intellectual property rights is granted under this document. If any part of this document refers to any third party products or services it shall not be deemed a license grant by ST for the use of such third party products or services, or any intellectual property contained therein or considered as a warranty covering the use in any manner whatsoever of such third party products or services or any intellectual property contained therein.

UNLESS OTHERWISE SET FORTH IN ST'S TERMS AND CONDITIONS OF SALE ST DISCLAIMS ANY EXPRESS OR IMPLIED WARRANTY WITH RESPECT TO THE USE AND/OR SALE OF ST PRODUCTS INCLUDING WITHOUT LIMITATION IMPLIED WARRANTIES OF MERCHANTABILITY, FITNESS FOR A PARTICULAR PURPOSE (AND THEIR EQUIVALENTS UNDER THE LAWS OF ANY JURISDICTION), OR INFRINGEMENT OF ANY PATENT, COPYRIGHT OR OTHER INTELLECTUAL PROPERTY RIGHT.

UNLESS EXPRESSLY APPROVED IN WRITING BY AN AUTHORIZED ST REPRESENTATIVE, ST PRODUCTS ARE NOT RECOMMENDED, AUTHORIZED OR WARRANTED FOR USE IN MILITARY, AIR CRAFT, SPACE, LIFE SAVING, OR LIFE SUSTAINING APPLICATIONS, NOR IN PRODUCTS OR SYSTEMS WHERE FAILURE OR MALFUNCTION MAY RESULT IN PERSONAL INJURY, DEATH, OR SEVERE PROPERTY OR ENVIRONMENTAL DAMAGE. ST PRODUCTS WHICH ARE NOT SPECIFIED AS "AUTOMOTIVE GRADE" MAY ONLY BE USED IN AUTOMOTIVE APPLICATIONS AT USER'S OWN RISK.

Resale of ST products with provisions different from the statements and/or technical features set forth in this document shall immediately void any warranty granted by ST for the ST product or service described herein and shall not create or extend in any manner whatsoever, any liability of ST.

ST and the ST logo are trademarks or registered trademarks of ST in various countries.

Information in this document supersedes and replaces all information previously supplied.

The ST logo is a registered trademark of STMicroelectronics. All other names are the property of their respective owners.

© 2007 STMicroelectronics - All rights reserved

STMicroelectronics group of companies

Australia - Belgium - Brazil - Canada - China - Czech Republic - Finland - France - Germany - Hong Kong - India - Israel - Italy - Japan - Malaysia - Malta - Morocco - Singapore - Spain - Sweden - Switzerland - United Kingdom - United States of America

www.st.com

