

# 1,024-Bit Serial Electrically Erasable PROM

## BR93LL46F / BR93LL46FV

●Features

- Low power CMOS technology
- 64 × 16 bit configuration
- 1.8V to 4.0V operation
- Low power dissipation
  - 0.5mA (typ.) active current
  - 0.4µA (typ.) standby current
- Auto increment for efficient data dump
- Automatic erase-before-write
- Hardware and software write protection
  - Defaults to write-disabled state at power up
  - Software instructions for write-enable / disable
  - Vcc lockout inadvertent write protection
- 8-pin SOP / 8-pin SSOP-B packages
- Device status signal during write cycle
- 100,000 ERASE / WRITE cycles
- 10 years Data Retention

●Pin assignments

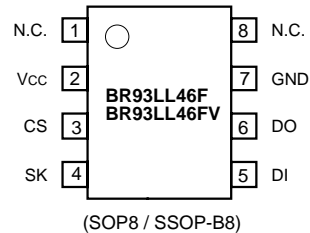

●Pin descriptions

Pin Name	Function
N.C.	Not connected
Vcc	Power supply
CS	Chip select input
SK	Serial clock input
DI	Start bit, operating code, address, and serial data input
DO	Serial data output, READY / BUSY internal status display output
GND	Ground
N.C.	Not connected

●Overview

The BR93LC46F and BR93LL46FV are CMOS serial input / output-type memory circuits (EEPROMs) that can be programmed electrically. Each is configured of 64 words × 16 bits (1,024 bits), and each word can be accessed individually and data read from it and written to it. Operation control is performed using five types of commands. The commands, addresses, and data are input through the DI pin under the control of the CS and SK pins. In a write operation, the internal status signal (READY or BUSY) can be output from the DO pin.

## ●Block diagram

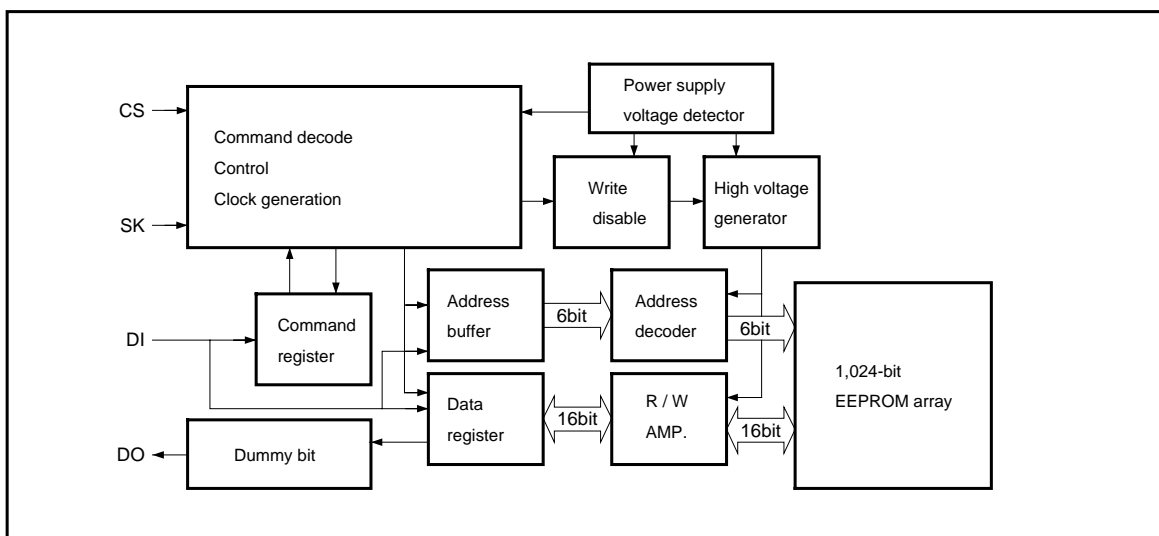

## ●Absolute maximum ratings

Parameter	Symbol	Limits	Unit
Applied voltage	$V_{CC}$	- 0.3 ~ + 7.0	V
Power dissipation	BR93LL46F	350*1	mW
	BR93LL46FV	300*2	
Storage temperature	$T_{stg}$	- 65 ~ + 125	°C
Operating temperature	$T_{opr}$	- 20 ~ + 70	°C
Terminal voltage	—	- 0.3 ~ $V_{CC} + 0.3$	V

\*1 Reduced by 3.5mW for each increase in  $T_a$  of 1°C over 25°C.

\*2 Reduced by 3.0mW for each increase in  $T_a$  of 1°C over 25°C.

## ●Recommended operating conditions

Parameter	Symbol	Limits	Unit	Conditions
Power supply voltage	$V_{CC}$	1.8 ~ 4.0	V	$T_a = 0 \sim 70^\circ\text{C}$
		2.0 ~ 4.0		$T_a = -20 \sim +70^\circ\text{C}$
Input voltage	$V_{IN}$	0 ~ $V_{CC}$	V	—

●Electrical characteristics (unless otherwise noted, Ta = -20 to +70°C, V<sub>CC</sub> = 1.8 to 4.0V)

Parameter	Symbol	Min.	Typ.	Max.	Unit	Conditions
Input low level voltage	V <sub>IL</sub>	-0.3	—	0.2 × V <sub>CC</sub>	V	—
Input high level voltage	V <sub>IH</sub>	0.8 × V <sub>CC</sub>	—	V <sub>CC</sub> + 0.3	V	—
Output low level voltage 1	V <sub>OL1</sub>	—	—	0.3	V	I <sub>OL</sub> = 1.0mA
Output low level voltage 2	V <sub>OL2</sub>	—	—	0.2	V	I <sub>OL</sub> = 20μA
Output high level voltage 2	V <sub>OH2</sub>	V <sub>CC</sub> - 0.3	—	—	V	I <sub>OH</sub> = 100μA
Input leakage current	I <sub>LI</sub>	-1.0	—	1.0	μA	V <sub>IN</sub> = 0V ~ V <sub>CC</sub>
Output leakage current	I <sub>LO</sub>	-1.0	—	1.0	μA	V <sub>OUT</sub> = 0V ~ V <sub>CC</sub> , CS = GND
Operating current dissipation 1	I <sub>CC1</sub>	—	0.5	1.0	mA	V <sub>IN</sub> = V <sub>IH</sub> / V <sub>IL</sub> , DO = OPEN, f <sub>SK</sub> = 250kHz WRITE
Operating current dissipation 2	I <sub>CC2</sub>	—	0.4	1.0	mA	V <sub>IN</sub> = V <sub>IH</sub> / V <sub>IL</sub> , DO = OPEN, f <sub>SK</sub> = 250kHz, READ
Standby current	I <sub>SB</sub>	—	0.4	1.0	μA	CS = SK = DI = GND, DO = OPEN

\*1 About the operating current dissipation

I<sub>CC1</sub> indicates the average current dissipation during a writing operation, and I<sub>CC2</sub> indicates the average current dissipation during a reading operation.

Because this is internal logic switching current, it changes based on the SK frequency.

\*2 About the standby current

This is the current dissipation when all inputs are CMOS level and in static state.

●Operation timing characteristics (Ta = -20 to +70°C, V<sub>CC</sub> = 1.8 to 4.0 V)

Parameter	Symbol	Min.	Typ.	Max.	Unit
SK clock frequency	f <sub>SK</sub>	—	—	250	kHz
SK "H" time	t <sub>SKH</sub>	1	—	—	μs
SK "L" time	t <sub>SKL</sub>	1	—	—	μs
CS "L" time	t <sub>CS</sub>	1	—	—	μs
CS setup time	t <sub>CSS</sub>	200	—	—	ns
DI setup time	t <sub>DIS</sub>	400	—	—	ns
CS hold time	t <sub>CSH</sub>	0	—	—	ns
DI hold time	t <sub>DIH</sub>	400	—	—	ns
Data "1" output delay time	t <sub>PD1</sub>	—	—	2	μs
Data "0" output delay time	t <sub>PD0</sub>	—	—	2	μs
Time from CS to output confirmation	t <sub>SV</sub>	—	—	2	μs
Time from CS to output High impedance	t <sub>DF</sub>	—	—	400	ns
Write cycle time	t <sub>E / W</sub>	—	—	25	ms

## ●Timing chart

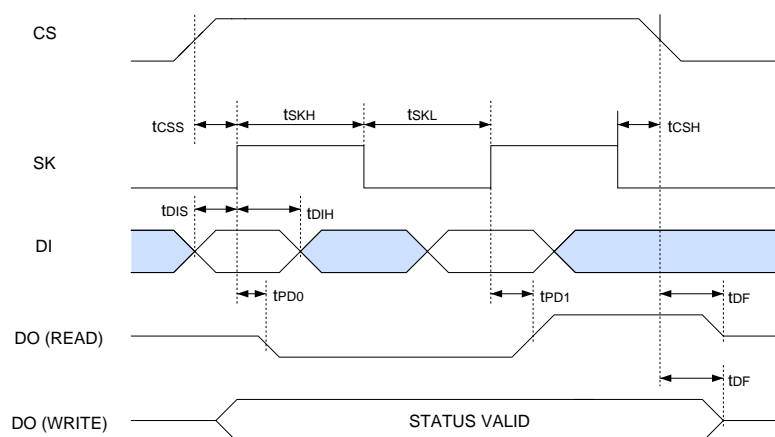

Fig. 1 Synchronous data timing

- (1) Data is acquired from DI in synchronization with the SK rise.
- (2) During a reading operation, data is output from DO in synchronization with the SK rise.
- (3) During a writing operation, a Status Valid (READY or BUSY) is valid from the time CS is HIGH until time

- $t_{CS}$  after CS falls following the input of a write command and before the output of the next command start bit. Also, DO must be in a HIGH-Z state when CS is LOW.
- (4) After the completion of each mode, make sure that CS is set to LOW, to reset the internal circuit, before changing modes.

## ●Circuit operation

## (1) Command mode

Command	Start bit	Operating code	Address	Data
Read (READ) (*1)	1	10	A5 ~ A0	—
Write enabled (WEN)	1	00	11XXXX	—
Write (WRITE) (*2)	1	01	A5 ~ A0	D15 ~ D0
Write disabled (WDS)	1	00	00XXXX	—

X: Either  $V_{IH}$  or  $V_{IL}$

## \* About the start bit

With these ICs, commands are not recognized or acted upon until the start bit is received. The start bit is taken as the first "1" that is received after the CS pin rises.

(\*1) After setting of the read command and input of the

SK clock, data corresponding to the specified address is output, with data corresponding to upper addresses then output in sequence. (Auto increment function)

(\*2) When the write command is executed, all data in the selected memory cell is erased automatically, and the input data is written to the cell.

## (2) Reading

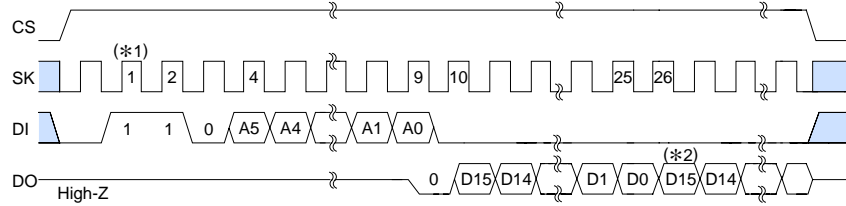

Fig.2 Read cycle timing (READ)

When the read command is acknowledged, the data (16 bits) for the input address is output serially. The data is synchronized with the SK rise during A0 acquisition and a "0" (dummy bit) is output. All further data is output in synchronization with the SK pulse rises.

## (\*1) Start bit

The start bit is taken as the first "1" that is received after the CS pin rises. Also, if "0" is input several times followed by "1", the "1" is recognized as a start bit, and subsequent operation commences.

This applies also to the following commands.

## (\*2) Address auto increment function

These ICs are equipped with an address auto increment function which is effective only during reading operations. With this function, if the SK clock is input following execution of one of the above reading commands, data is read from upper addresses in succession. CS is held in HIGH state during automatic incrementing.

## (3) Write enable

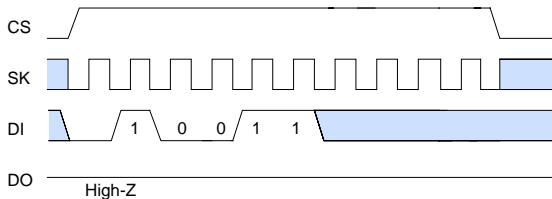

Fig.3 Cycle timing that allows overwriting

These ICs are set to the write disabled state by the internal reset circuit when the power is turned on. Therefore, before performing a write command, the write enable command must be executed. When this command is executed, it remains valid until a write disable command is issued or the power supply is cut off. However, read commands can be used in either the write enable or write disable state.

## (4) Write

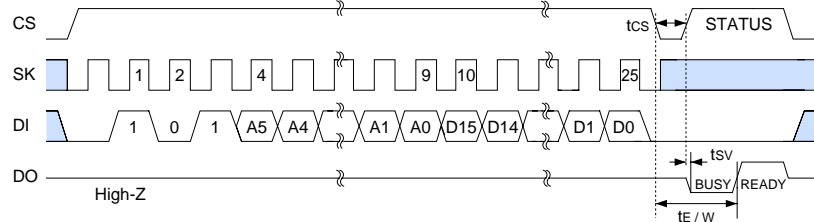

Fig. 4 Write cycle timing (WRITE)

This command writes the 16-bit data (D15 to D0) to the specified address (A5 to A0). The actual writing begins when CS falls following the fall of the SK clock (the 25th clock pulse after the start bit) when D0 is read.

If STATUS is not detected (CS is fixed at LOW, or if STATUS is detected (CS is HIGH) at timing  $t_{E/W}$ , no commands will be received as long as a LOW state (BUSY) is output from DO, so command input should be avoided.

## \* STATUS

After time  $t_{cs}$  following the fall of CS, after input of the write command, if CS is set to HIGH, the write execute = BUSY (LOW) and the command wait status READY (HIGH) are output.

If in the command wait status (STATUS = READY), the next command can be performed within the time  $t_{E/W}$ . Thus, if data is input via SK and DI with CS = HIGH in the  $t_{E/W}$  period, erroneous operations may be performed. To avoid this, make sure that DI = LOW when CS = HIGH. (Caution is especially important when common input ports are used.) This applies to all of the write commands.

## (5) Write disable

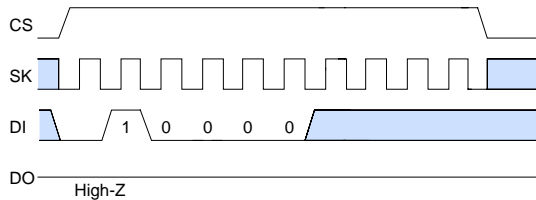

Fig. 5 Write disable cycle timing (WDS)

When the power supply is turned on, if the write enable command is issued, the write enable state is entered. If the write disable command is then issued, the IC enters the write disable status. When in this status, all write commands are ignored, but read commands may be executed.

In the write enable status, writing begins even if a write command is entered accidentally. To prevent errors of this type, we recommend executing a write disable command after writing has been completed.

● Operation notes

(1) Cancelling modes

<READ>

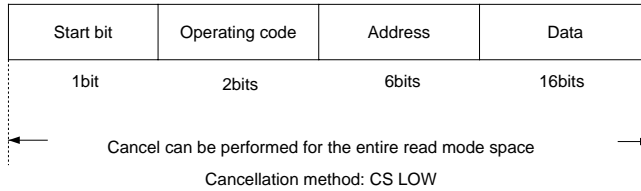

<WRITE>

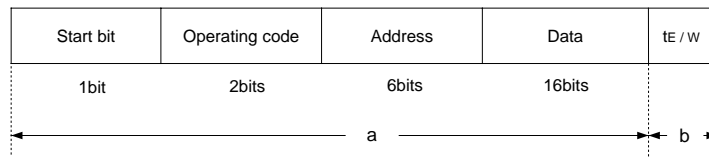

a: Canceled by setting CS LOW or V<sub>CC</sub> OFF (☆)

☆: V<sub>CC</sub> OFF (V<sub>CC</sub> is turned off after CS is set to LOW)

b: Cannot be canceled by any method. If V<sub>CC</sub> is set to OFF during this time, the data in the designated address is not secured.

(2) Timing in the standby mode

As shown in Figure a, during standby, if CS rises when SK is HIGH, the DI state may be read on the rising edge. If this happens, and DI is HIGH, this is taken to

be the start bit, causing a bit error (see point “a” in Figure a).

Make sure all inputs are LOW during standby or when turning the power supply on or off (see Figure b).

Point a: Start bit position when error occurs

Point b: Actual start bit position

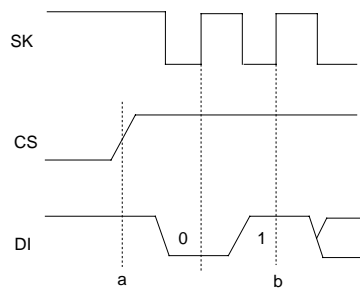

(Figure a. Erroneous operation timing)

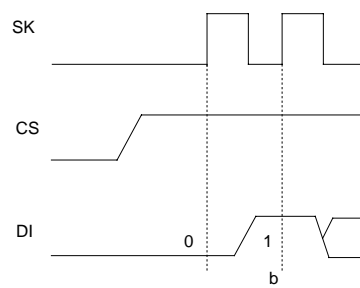

(Figure b. Normal operation timing)

## (3) Precautions when turning power on and off

○When turning the power supply on and off, make sure CS is set to LOW (see Figure 6).

When CS is HIGH, the EEPROM enters the active state. If the power supply is turned on in this state, noise and other factors can cause malfunctions and erroneous writing. To avoid this, make sure CS is set to LOW (disable mode) when turning on the power supply. (When CS is LOW, all input is cancelled.)

When the power supply is turned off, the low power state can continue for a long time because of the capacity of the power supply line. Erroneous operations and erroneous writing can occur at such times for the same reasons as described above. To avoid this, make sure CS is set to LOW before turning off the power supply.

To prevent erroneous writing, these ICs are equipped with a POR (Power On Reset) circuit, but in order to achieve operation at a low power supply,  $V_{CC}$  is set to operate at approximately 1.3V. After the POR has been activated, writing is disabled, but if CS is set to HIGH, writing may be enabled because of noise or other factors. However, the POR circuit is effective only when the power supply is on, and will not operate when the power is off. Also, to prevent erroneous writing at low voltages, these ICs are equipped with a built-in circuit which resets the write command if  $V_{CC}$  drops to approximately 1.5V or lower (typ.)

( $V_{CC}$ -lockout circuit)

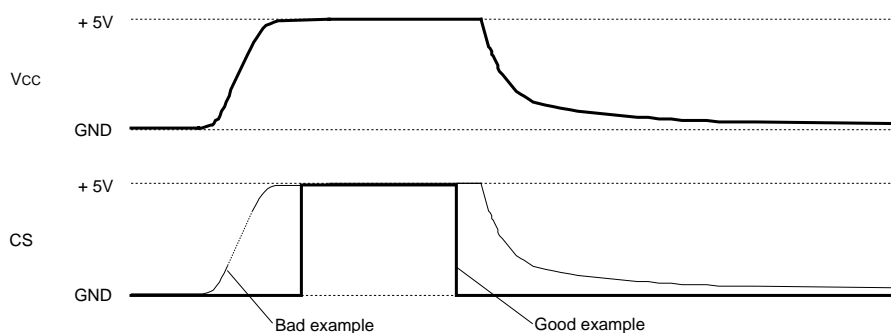

Fig.6

(Bad example) Here, the CS pin is pulled up to  $V_{CC}$ .

In this case, CS is HIGH (active state). Please be aware that the EEPROM may perform erroneous operations or write erroneous data because of noise or other factors.

\* Even if the CS input is HIGH-Z, please be aware that cases such as this can occur.

(Good example) In this case, CS is LOW when the power supply is turned on or off.

## (4) Clock (SK) rise conditions

If the clock pin (SK) signal of the BR93LL46F / FV has a long rise time ( $T_r$ ) and if noise on the signal line exceeds a certain level, erroneous operation can occur due to erroneous counts in the clock. To prevent this, a Schmitt trigger is built into the SK input of the BR93LL46F / FV. The hysteresis amplitude of this circuit is

set to approximately 0.2V, so if the noise exceeds the SK input, the noise amplitude should be set to 0.2  $V_{P-P}$  or lower. Furthermore, rises and falls in the clock input should be accelerated as much as possible.



## ● Operation notes

## (5) Connecting DI and DO directly

The BR93LL46F / FV have an independent input pin (DI) and output pin (DO). These are treated as individual signals on the timing chart but can be controlled through one control line. Control can be initiated on a single control line by treating these signals as separate in the timing chart.

1) Data collision between the  $\mu$ -COM output and the DO output

Within the input and output timing of the BR93LL46F / FV, the drive from the  $\mu$ -COM output to the DI input and a signal output from the DO output can be emitted at the same time. This happens only for the 1 clock cycle (a dummy bit "0" is output to the DO pin) which acquires the A0 address data during a read cycle.

→ When the address data A0 = 1, a feedthrough current path occurs.

Timing after a write command, when CS is HIGH

A READY or BUSY function is output on the DO pin. When the next start bit is input, DO goes to the high impedance state.

→ When inputting a command after a write, when the CS input rises while the  $\mu$ -COM output remains LOW, a READY output HIGH is output from the DO pin and feedthrough current paths can occur.

2) When the  $\mu$ -COM port is the CMOS port

The  $\mu$ -COM port can be controlled by the 1 control line by connecting a resistor R between the DI and DO pins during CMOS input and output, as shown in Figure 7.

In this case, the value of R needs to satisfy the positive portion of the  $\mu$ -COM input level for the voltage drop at R resulting from the leak current of the  $\mu$ -COM input and the DI pin. It must be as small as possible so that it does not influence the DO output noise but large enough to keep the feedthrough current to a minimum. A value in the range of 1K-200k $\Omega$  is usually sufficient. Make sure to confirm this through experiment. In this case, a dummy bit cannot be detected.

## 3) Feedback to the DI input from the DO output

Data is output from the DO pin and then feeds back into the DI input through the resistor R. This happens when:

1. DO data is output during a read operation
2. A READY / BUSY signal is output during a write operation

Such feedback does not cause problems in the basic

operation of the BR93LL46F / FV.

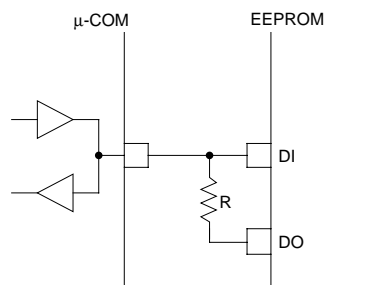

Fig. 7 Using the CMOS port

4) When the  $\mu$ -COM port is the open drain port  
 When the  $\mu$ -COM port is the open drain output port, it responds through software as shown in Figure 8. This method will not work during CMOS input and output. The timing which becomes a problem (production of feedthrough current paths) for the open drain port only occurs when CS is HIGH after a write command. Feedthrough current paths can occur in the period between the rise of the CS to the input of the start bit. If CS rises before the start bit, as shown in Figure 8, and DI is HIGH at the same time, current paths are not created. Make sure to set SK to LOW during a CS rise.

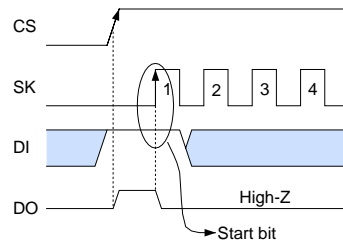
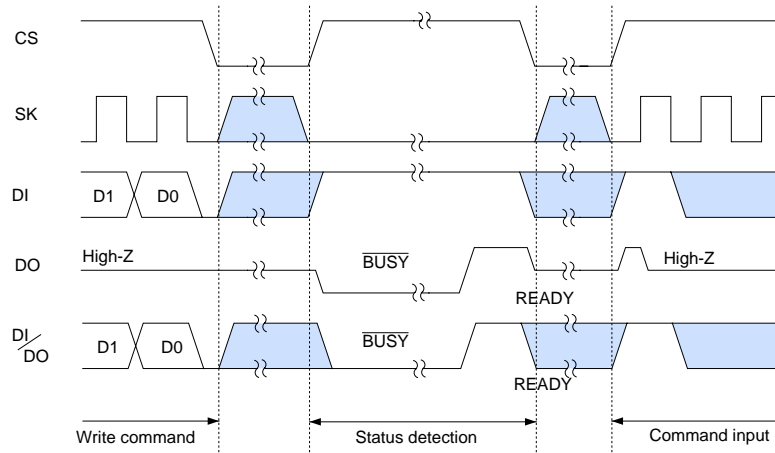

Fig. 8 Using an open drain port

In this case, however, the first SK rise after the CS rises is interpreted as the start bit. Therefore, caution is required. Figure 9 shows a timing chart from the end of a write command to the next command input. As shown in the figure, after completion of the write command input, when CS rises, set SK to LOW and stop the SK input. Otherwise, if DO is HIGH when a clock pulse is input, this is taken as the start bit and may cause erroneous operation.



\* DI: EEPROM DI terminal; DO: EEPROM DO output; DI / DO:  $\mu$ -COM I / O terminal

Fig. 9 Timing diagram chart

●External dimensions (Units: mm)

