

Features

- Fast Interleave Cycle Time - 35 ns
- Continuous Memory Interleaving
 - Unlimited Linear Access Data Output
- Dual Voltage Range Operation
 - Low Voltage Power Supply Range, 3.0V to 3.6V or Standard 5V \pm 10% Supply Range
- Low Power CMOS Operation
 - 108 mW max. Active at 25 MHz for $V_{CC} = 3.6V$
 - 14.4 mW max. Standby for $V_{CC} = 3.6V$
- JEDEC Standard Surface Mount Packages
 - 44-Lead PLCC
 - 40-Lead VSOP (10 x 14mm)
- High Reliability CMOS Technology
 - 2,000V ESD Protection
 - 200 mA Latchup Immunity
- Rapid™ Programming Algorithm - 50 μ s/word (typical)
- CMOS and TTL Compatible Inputs and Outputs
 - JEDEC Standard for LVTTTL
- Integrated Product Identification Code
- Commercial and Industrial Temperature Ranges

Description

The AT27LV1026 is a high performance 16-bit interleaved low-voltage 1,048,576-bit one-time programmable read only memory (OTP EPROM) organized as 2 x 32K x 16 bits. It requires only one supply in the range of 3.0V to 3.6V in normal read mode operation.

Pin Configurations

Pin Name	Function
A0 - A15	Addresses
O0 - O15	Outputs
\overline{CS}	Chip Select
\overline{RD}	Read Strobe
ALE	Address Latch Enable
\overline{PGM}	Program Strobe
NC	No Connect

Note: Both GND pins must be connected.

PLCC Top View

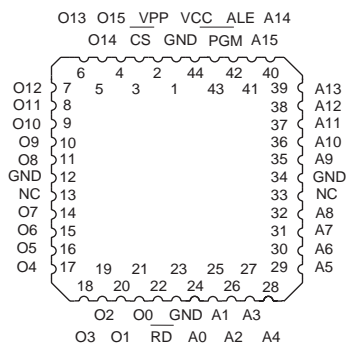

VSOP Top View
Type 1

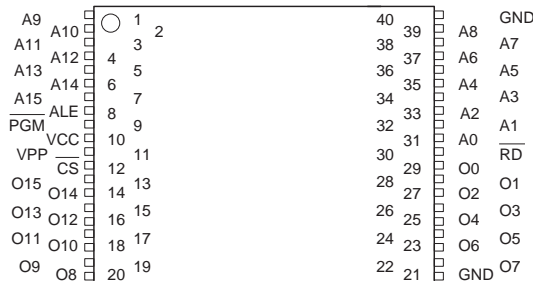

Rev. 0956D-02/98



**1-Megabit
(2 x 32K x 16)
16-Bit Interleaved
Low-Voltage OTP
EPROM**

**AT27LV1026
Preliminary**



This device is internally architected as two 32K x 16 memory banks, odd and even. To begin a non-linear access NLA cycle, (which typically equals a minimum of two linear access LA cycles), ALE is asserted high and \overline{CS} is asserted low. The two internal 15-bit counters store the address for the odd and even banks and increment alternately during each subsequent linear access LA cycle. The LA cycle will be terminated when \overline{CS} is asserted high putting the device in standby mode, or another NLA cycle starts. The LA cycle can be resumed when \overline{CS} is asserted low and ALE stays low. The AT27LV1026 will continuously output data within each LA cycle which is determined by the read \overline{RD} signal. Continuous interleave read operation is possible as there is no physical limit to the linear access LA output. When the last address in the array is reached the counters will wrap around to the first address location and continue.

For a NLA cycle where $A0 = 0$ (ALE asserted high, \overline{CS} asserted low), both even and odd counters will be loaded with new address (A1 - A15). Outputs (O0 - O15) from the even bank will be valid in t_{ACCNLA} within the NLA cycle, the outputs from the odd bank will become valid in t_{ACCLA} within the following LA cycle while the even counter increments by one to ready the data out for the next LA cycle. The outputs will have even or odd data alternating and the counters increment for the consecutive LA cycles until \overline{CS} is asserted high putting the device in standby mode, or a new NLA cycle begins.

For a NLA cycle where $A0 = 1$ (ALE asserted high, \overline{CS} asserted low), the odd counter will be loaded with the new address (A1 - A15) while the even counter gets loaded with

the new address+1. Outputs (O0 - O15) from odd bank of memory will be valid in t_{ACCNLA} within the NLA cycle, the data output from the even bank of memory will become valid in t_{ACCLA} within the following LA cycle while the odd counter increments by one to ready the data out for the next LA cycle. The outputs will have data from the odd or even memory bank alternately and the counters increment for the following consecutive LA cycles until \overline{CS} is asserted high putting the device in standby mode, or a new NLA cycle begins. When coming out of standby mode, the device can either enter into a new NLA cycle or resume where the previous LA operation left off and was terminated by standby mode.

System Considerations

Switching under active conditions may produce transient voltage excursions. Unless accommodated by the system design, these transients may exceed data sheet limits, resulting in device non-conformance. At a minimum, a 0.1 μ F high frequency, low inherent inductance, ceramic capacitor should be utilized for each device. This capacitor should be connected between the V_{CC} and Ground terminals of the device, as close to the device as possible. Additionally, to stabilize the supply voltage level on printed circuit boards with large EPROM arrays, a 4.7 μ F bulk electrolytic capacitor should be utilized, again connected between the V_{CC} and Ground terminals. This capacitor should be positioned as close as possible to the point where the power supply is connected to the array.

Operating Table

If $A0 = 0$ at beginning of NLA cycle:

Consecutive Cycle	Counter		Outputs
	Even	Odd	
NLA	Address	Address	from Even Bank
LA	+1	-	from Odd Bank
LA	-	+1	from Even Bank
LA	+1	-	from Odd Bank
LA	-	+1	from Even Bank
Standby			HiZ
LA	+1	-	from Odd Bank
LA	-	+1	from Even Bank

and so on.

If $A0 = 1$ at beginning of NLA cycle:

Consecutive Cycle	Counter		Outputs
	Even	Odd	
NLA	Address+1	Address	from Odd Bank
LA	-	+1	from Even Bank
LA	+1	-	from Odd Bank
LA	-	+1	from Even Bank
LA	+1	-	from Odd Bank
Standby			HiZ
LA	-	+1	from Even Bank
LA	+1	-	from Odd Bank

and so on.

Block Diagram

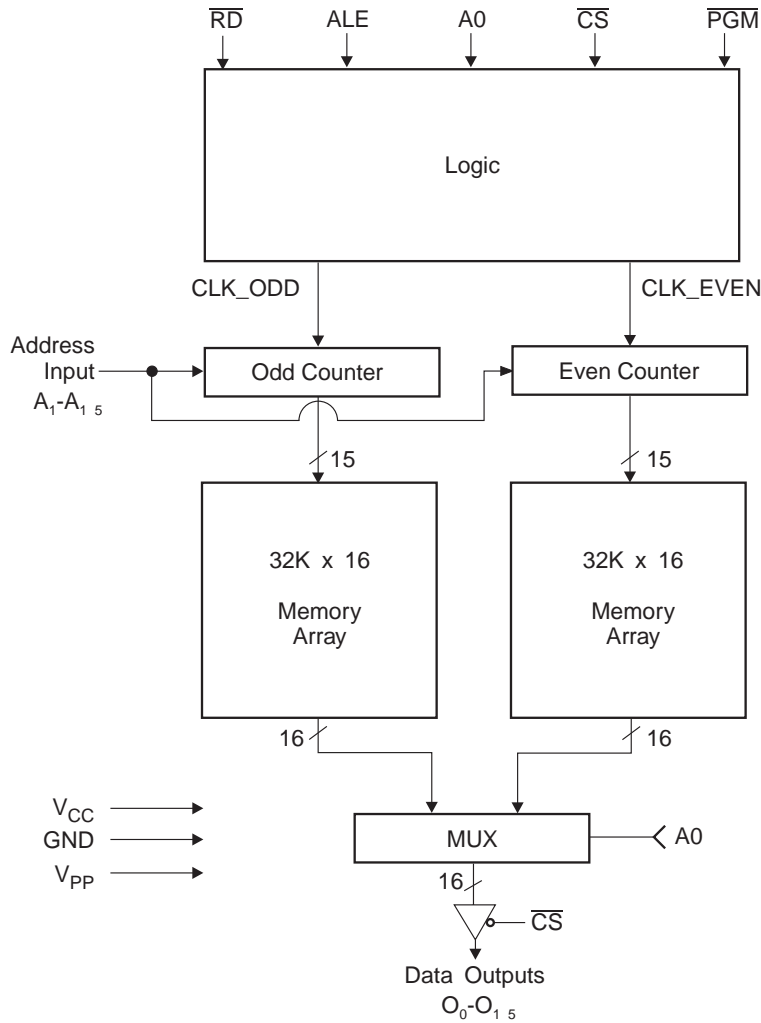

Absolute Maximum Ratings*

Temperature Under Bias	-55°C to +125°C
Storage Temperature	-65°C to +150°C
Voltage on Any Pin with Respect to Ground	-2.0V to +7.0V ⁽¹⁾
Voltage on A9 with Respect to Ground	-2.0V to +14.0V ⁽¹⁾
V _{PP} Supply Voltage with Respect to Ground	-2.0V to +14.0V ⁽¹⁾

*NOTICE: Stresses beyond those listed under “Absolute Maximum Ratings” may cause permanent damage to the device. This is a stress rating only and functional operation of the device at these or any other conditions beyond those indicated in the operational sections of this specification is not implied. Exposure to absolute maximum rating conditions for extended periods may affect device reliability.

Note: 1. Minimum voltage is -0.6V DC which may undershoot to -2.0V for pulses of less than 20 ns. Maximum output pin voltage is V_{CC} + 0.75V DC which may overshoot to +7.0V for pulses of less than 20 ns.



Operating Modes

Mode/Pin	ALE	\overline{CS}	\overline{RD}	\overline{PGM}	A ₀	A ₁ - A ₁₅	V _{PP}	V _{CC}	Outputs
Non-Linear Access Cycle ⁽²⁾		V _{IL}	V _{IL}	V _{IH}	V _{IL} /V _{IH}	A _i	X	V _{CC} ⁽²⁾	D _{OUT}
Linear Access Cycle ⁽²⁾	V _{IL}	V _{IL}		V _{IH}	X ⁽¹⁾	X	X	V _{CC} ⁽²⁾	D _{OUT}
Standby ⁽²⁾	X	V _{IH}	X	V _{IH}	X	X	X	V _{CC} ⁽²⁾	High Z
Rapid Program ⁽³⁾	V _{IH}	V _{IH}	V _{IL}	V _{IL}	V _{IL} /V _{IH}	A _i	V _{PP}	V _{CC} ⁽³⁾	D _{IN}
PGM Verify ⁽³⁾	V _{IH}	V _{IL}	V _{IL}	V _{IH}	V _{IL} /V _{IH}	A _i	V _{PP}	V _{CC} ⁽³⁾	D _{OUT}
PGM Inhibit ⁽³⁾	X	V _{IH}	X	V _{IH}	X	X	V _{PP}	V _{CC} ⁽³⁾	High Z
Product Identification ⁽³⁾⁽⁵⁾	X	V _{IL}	X	V _{IH}	V _{IL} /V _{IH}	A ₉ = V _H ⁽⁴⁾ A ₁ - A ₁₅ = V _{IL}	V _{CC}	V _{CC} ⁽³⁾	Identification Code

Notes: 1. X can be V_{IL} or V_{IH}.

2. Non-Linear and Linear Access Cycles, and standby modes require, $3.0V \leq V_{CC} \leq 3.6V$, or $4.5V \leq V_{CC} \leq 5.5V$.

3. Refer to Programming Characteristics. Programming modes require V_{CC} = 6.5V.

4. V_H = 12.0 ± 0.5V.

5. Two identifier words may be selected. All A_i inputs are held low (V_{IL}), except A₉ which is set to V_H and A₀ which is toggled low (V_{IL}) to select the Manufacturer's Identification word and high (V_{IH}) to select the Device Code word.

DC and AC Operating Conditions for Read Operation

		AT27LV1026		
		-35	-45	-55
Operating Temperature (Case)	Com.	0°C - 70°C	0°C - 70°C	0°C - 70°C
	Ind.	-40°C - 85°C	-40°C - 85°C	-40°C - 85°C
V _{CC} Power Supply		3.0V - 3.6V	3.0V - 3.6V	3.0V - 3.6V
		5V ± 10%	5V ± 10%	5V ± 10%

DC and Operating Characteristics for Read Operation

Symbol	Parameter	Condition	Min	Max	Units
V_{CC} = 3.0V to 3.6V					
I _{LI}	Input Load Current	V _{IN} = 0V to V _{CC}		±1	µA
I _{LO}	Output Leakage Current	V _{OUT} = 0V to V _{CC}		±5	µA
I _{PP1} ⁽²⁾	V _{PP} ⁽¹⁾ Read/Standby Current	V _{PP} = V _{CC}		10	µA
I _{SB}	V _{CC} ⁽¹⁾ Standby Current	$\overline{CS} = V_{IH}$		4	mA
I _{CC}	V _{CC} Active Current	f = 25 MHz, I _{OUT} = 0 mA, $\overline{CS} = V_{IL}$		30	mA
V _{IL}	Input Low Voltage		-0.6	0.8	V
V _{IH}	Input High Voltage		2.0	V _{CC} + 0.5	V
V _{OL}	Output Low Voltage	I _{OL} = 2.0 mA		0.4	V
V _{OH}	Output High Voltage	I _{OH} = -2.0 mA	2.4		V
V_{CC} = 4.5V to 5.5V					
I _{LI}	Input Load Current	V _{IN} = 0V to V _{CC}		±1	µA
I _{LO}	Output Leakage Current	V _{OUT} = 0V to V _{CC}		±5	µA
I _{PP1} ⁽²⁾	V _{PP} ⁽¹⁾ Read/Standby Current	V _{PP} = V _{CC}		10	µA
I _{SB}	V _{CC} ⁽¹⁾ Standby Current	$\overline{CS} = V_{IH}$		6	mA
I _{CC}	V _{CC} Active Current	f = 25 MHz, I _{OUT} = 0 mA, $\overline{CS} = V_{IL}$		50	mA
V _{IL}	Input Low Voltage		-0.6	0.8	V
V _{IH}	Input High Voltage		2.0	V _{CC} + 0.5	V
V _{OL}	Output Low Voltage	I _{OL} = 2.1 mA		0.4	V
V _{OH}	Output High Voltage	I _{OH} = -400 µA	2.4		V

- Notes:
1. V_{CC} must be applied simultaneously with or before V_{PP} and removed simultaneously with or after V_{PP}
 2. V_{PP} may be connected directly to V_{CC}, except during programming. The supply current would then be the sum of I_{CC} and I_{PP}



AC Characteristics for Read Operation ($V_{CC} = 3.0V$ to $3.6V$ and $4.5V$ to $5.5V$)

Symbol	Parameter	Condition	AT27LV1026			Units
			Min	Typ	Max	
t_{NLACYC}	Non-Linear Access Cycle		70	80		ns
t_{LACYC}	Linear Access Cycle	$ALE = \overline{CS} = V_{IL}$	35	40		ns
t_{ALE}	ALE High Width		7.5			ns
t_{AS}	Address/ \overline{CS} Setup Time		2.5			ns
t_{AH}	Address Hold Time		20			ns
t_{ARD}	ALE Low to \overline{RD} Low		5			ns
$t_{RD L}$	\overline{RD} Low Width	$ALE = \overline{CS} = V_{IL}$	13			ns
$t_{RD H}$	\overline{RD} High Width	$ALE = \overline{CS} = V_{IL}$	12			ns
t_{ACCNLA}	Address to Output Delay in Non-Linear Address Cycle from ALE Low				52	ns
t_{ACCLA}	Output Valid Delay in Linear Address Cycle from \overline{RD} High	$ALE = \overline{CS} = V_{IL}$			17	ns
$t_{DF}^{(2)(3)}$	\overline{CS} High to Output Float				14	ns
t_{OH}	Output Hold from \overline{CS} High		0			ns
t_{CS}	Output Valid Delay from \overline{CS} Low in Linear Address Cycle				17	ns
t_{RC}	\overline{RD} High to \overline{CS} Falling Edge Delay		10			ns
t_{CR}	\overline{CS} Falling Edge to \overline{RD} Low Delay		12			ns
t_{CA}	\overline{CS} Rising Edge to ALE Low Delay		2.5			ns

Notes: 2, 3. - See AC Waveforms for Read Operation.

AC Waveforms for Read Operation⁽¹⁾

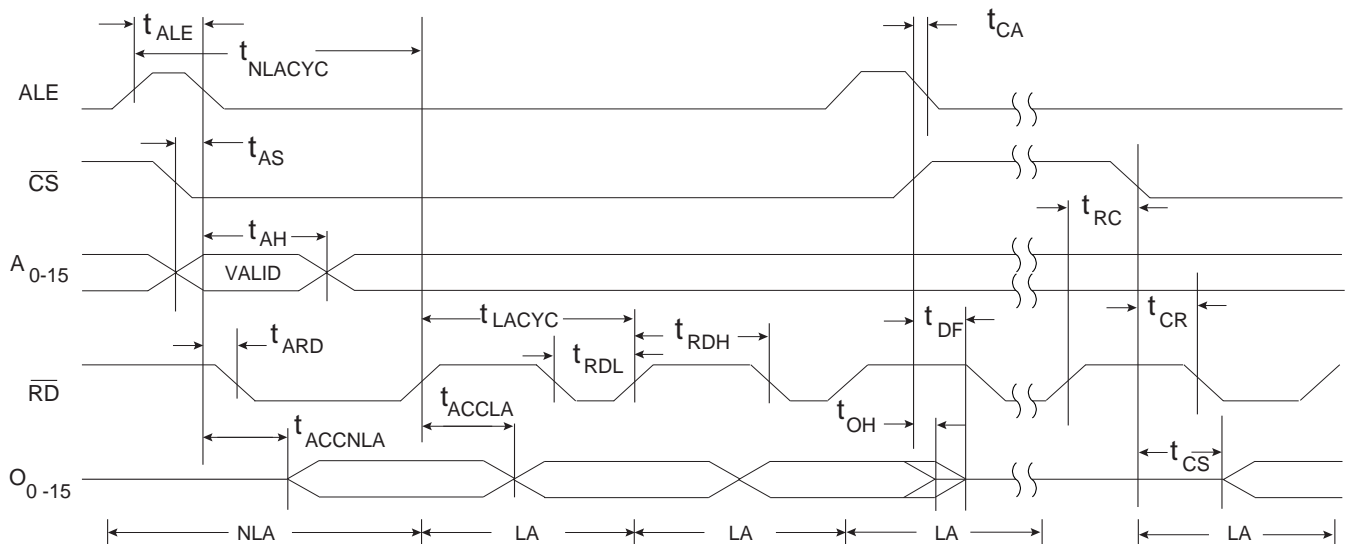

- Notes:
1. Refer to Test Waveforms and Measurement Levels diagram on next page.
 2. This parameter is only sampled and is not 100% tested.
 3. Output float is defined as the point when data is no longer driven.
 4. When reading a 27LV1026, a $0.1 \mu F$ capacitor is required across V_{CC} and ground to suppress spurious voltage transients.

Input Test Waveforms and Measurement Levels

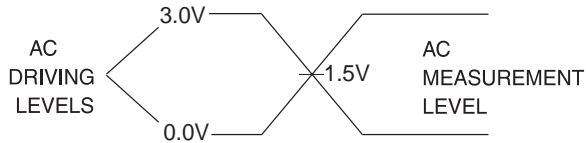

$t_R, t_F < 2.5 \text{ ns}$ (10% to 90%)

Output Test Load

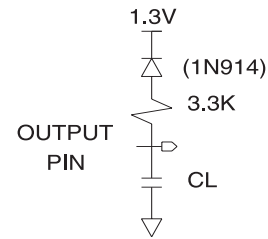

Note: $C_L = 100 \text{ pF}$ including jig capacitance.

Pin Capacitance ($f = 1 \text{ MHz}$ $T = 25^\circ\text{C}$)⁽¹⁾

	Typ	Max	Units	Conditions
C_{IN}	4	10	pF	$V_{IN} = 0V$
C_{OUT}	8	12	pF	$V_{OUT} = 0V$

Note: 1. Typical values for nominal supply voltage. This parameter is only sampled and is not 100% tested.

Programming Waveforms⁽¹⁾

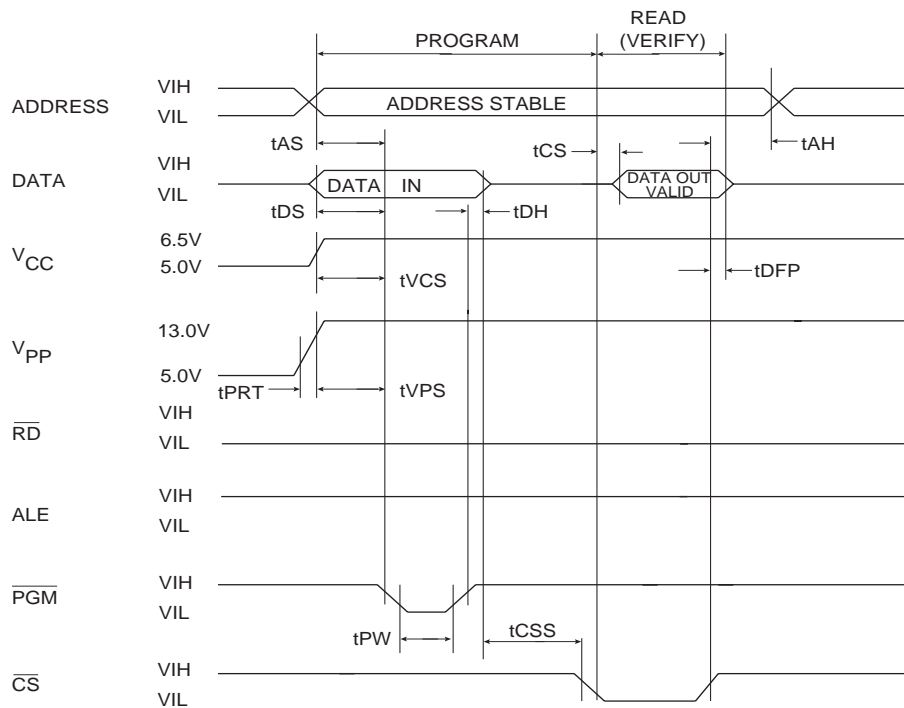

- Notes:
1. The Input Timing Reference is 0.8V for V_{IL} and 2.0V for V_{IH} .
 2. t_{CS} and t_{DFP} are characteristics of the device but must accompanied by the programmer.
 3. When programming the AT27LV1026 a 0.1 μF capacitor is required across V_{PP} and ground to suppress spurious voltage transients.

DC Programming Characteristics

$T_A = 25 \pm 5^\circ\text{C}$, $V_{CC} = 6.5 \pm 0.25\text{V}$, $V_{PP} = 13.0 \pm 0.25\text{V}$

Symbol	Parameter	Test Conditions	Limits		Units
			Min	Max	
I_{LI}	Input Load Current	$V_{IN} = V_{IL}, V_{IH}$		± 10	μA
V_{IL}	Input Low Level		-0.6	0.8	V
V_{IH}	Input High Level		2.0	$V_{CC} + 0.1$	V
V_{OL}	Output Low Voltage	$I_{OL} = 2.1 \text{ mA}$		0.4	V
V_{OH}	Output High Voltage	$I_{OH} = -400 \mu\text{A}$	2.4		V
I_{CC2}	V_{CC} Supply Current (Program and Verify)			50	mA
I_{PP2}	V_{PP} Supply Current	$\overline{\text{PGM}} = V_{IL}$		30	mA
V_{ID}	A9 Product Identification Voltage		11.5	12.5	V

AC Programming Characteristics

$T_A = 25 \pm 5^\circ\text{C}$, $V_{CC} = 6.5 \pm 0.25\text{V}$, $V_{PP} = 13.0 \pm 0.25\text{V}$

Symbol	Parameter	Test Conditions ⁽¹⁾	Limits		Units
			Min	Max	
t_{AS}	Address Setup Time	Input Rise and Fall Times (10% to 90%) 20 ns	2		μs
t_{CSS}	\overline{CS} Setup Time		2		μs
t_{DS}	Data Setup Time		2		μs
t_{AH}	Address Hold Time		0		μs
t_{DH}	Data Hold Time	Input Pulse Levels 0.45V to 2.4V	2		μs
t_{DFP}	\overline{CS} High to Output Float Delay ⁽²⁾		0	130	ns
t_{VPS}	V_{PP} Setup Time	Input Timing Reference Level 0.8V to 2.0V	2		μs
t_{VCS}	V_{CC} Setup Time		2		μs
t_{PW}	\overline{PGM} Program Pulse Width ⁽³⁾	Output Timing Reference Level 0.8V to 2.0V	45	55	μs
t_{CS}	Data Valid from \overline{CS}			150	ns
t_{PRT}	V_{PP} Pulse Rise Time During Programming		50		ns

- Notes:
- V_{CC} must be applied simultaneously or before V_{PP} and removed simultaneously or after V_{PP}
 - This parameter is only sampled and is not 100% tested. Output Float is defined as the point where data is no longer driven — see timing diagram.
 - Program Pulse width tolerance is $50 \mu\text{sec} \pm 5\%$.

Atmel's 27LV1026 Integrated Product Identification Code

Codes	Pins										Hex Data
	A0	015-08	O7	O6	O5	O4	O3	O2	O1	O0	
Manufacturer	0	0	0	0	0	1	1	1	1	0	001E
Device Type	1	0	0	1	1	0	0	0	0	1	0061



Rapid Programming Algorithm

A 50 μs $\overline{\text{PGM}}$ pulse width is used to program. The address is set to the first location. V_{CC} is raised to 6.5V and V_{PP} is raised to 13.0V. Each address is first programmed with one 50 μs $\overline{\text{PGM}}$ pulse without verification. Then a verification / reprogramming loop is executed for each address. In the event a word fails to pass verification, up to 10 successive 50 μs pulses are applied with a verification after each

pulse. If the word fails to verify after 10 pulses have been applied, the part is considered failed. After the word verifies properly, the next address is selected until all have been checked. V_{PP} is then lowered to 5.0V and V_{CC} to 5.0V. All words are read again and compared with the original data to determine if the device passes or fails.

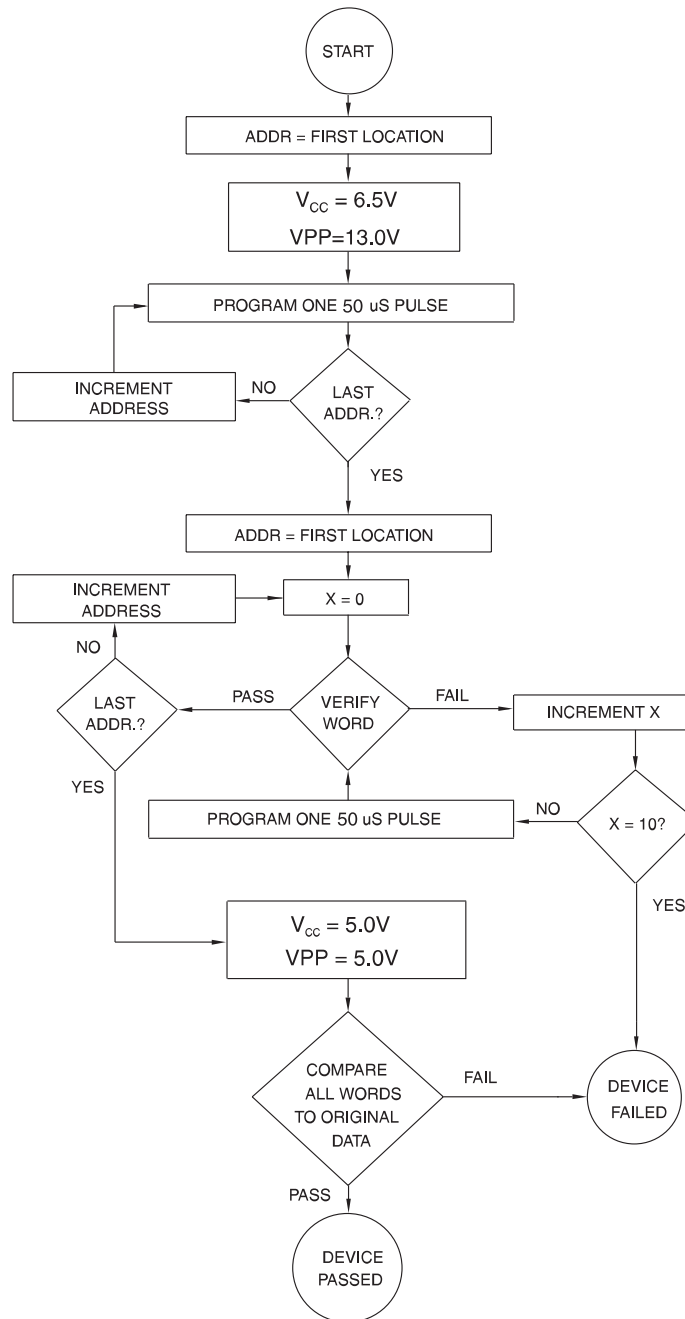

Ordering Information

t _{ACC} (ns)	I _{CC} (mA)		Ordering Code	Package	Operation Range
	Active	Standby			
35	30	0.1	AT27LV1026-35JC	44J	Commercial (0°C to 70°C)
			AT27LV1026-35VC	40V	
	30	0.1	AT27LV1026-35JI	44J	Industrial (-40°C to 85°C)
			AT27LV1026-35VI	40V	
45	30	0.1	AT27LV1026-45JC	44J	Commercial (0°C to 70°C)
			AT27LV1026-45VC	40V	
	30	0.1	AT27LV1026-45JI	44J	Industrial (-40°C to 85°C)
			AT27LV1026-45VI	40V	
55	30	0.1	AT27LV1026-55JC	44J	Commercial (0°C to 70°C)
			AT27LV1026-55VC	40V	
	30	0.1	AT27LV1026-55JI	44J	Industrial (-40°C to 85°C)
			AT27LV1026-55VI	40V	

Package Type	
44J	44-Lead, Plastic J-Leaded Chip Carrier (PLCC)
40V	40-Lead, Plastic Thin Small Outline Package (VSOP) 10 x 14 mm



Packaging Information

44J, 44-Lead, Plastic J-Leaded Chip Carrier (PLCC)
 Dimensions in Inches and (Millimeters)
 JEDEC STANDARD MS-018 AC

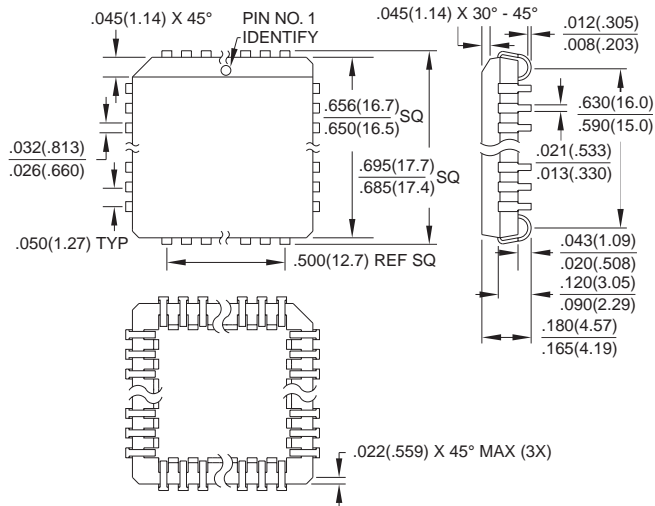

40V, 40-Lead, Plastic Thin Small Outline Package (VSOP) Dimension in Millimeters and (Inches)
 JEDEC OUTLINE MO-142 CA

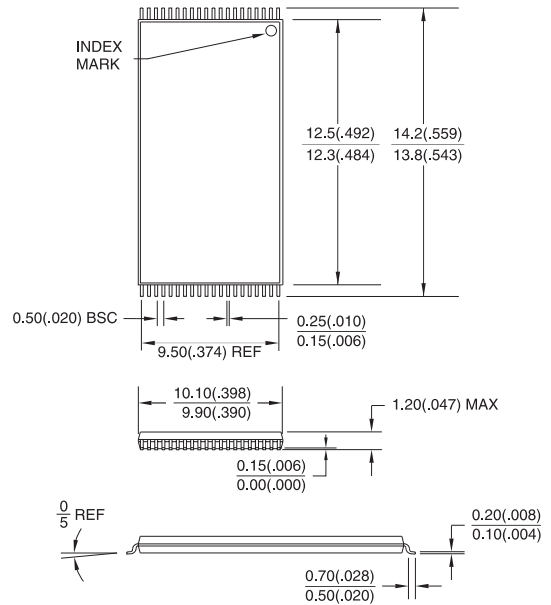

*Controlling dimension: millimeters