

1.5V dual auto-reverse preamplifier

BA3413FS

The BA3413FS is a 1.5V dual auto-reverse preamplifier designed for playback operation only. It includes built-in circuits for metal tape and auto-reverse applications, and its significantly streamlined component side offers a minimal requirement for external components.

●Applications

1.5V headphone stereos

●Features

- 1) Low noise.
- 2) Can be directly coupled to the tape head.
- 3) Supports auto-reverse.
- 4) Supports metal tape.
- 5) Good reduced voltage characteristics (0.9V Typ.).

●Block diagram

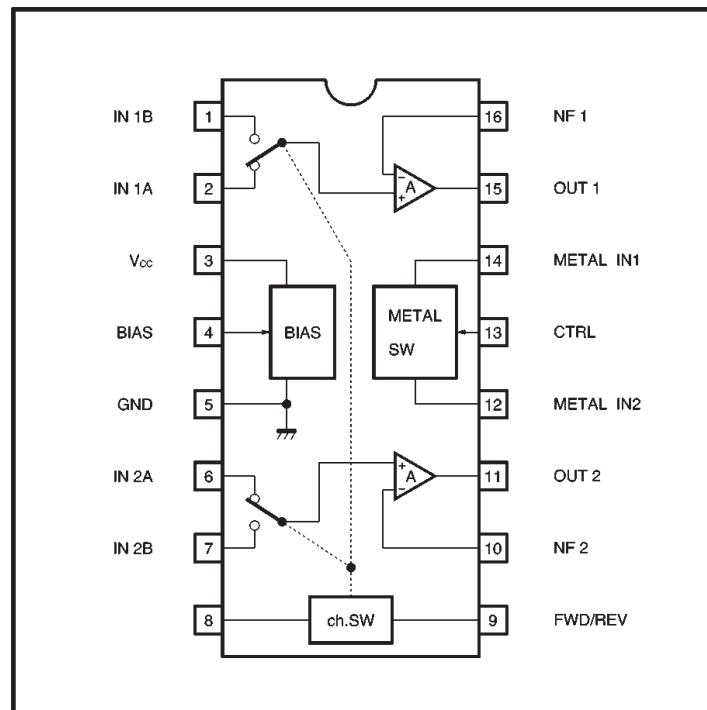

●Absolute maximum ratings (Ta = 25°C)

Parameter	Symbol	Limits	Unit
Power supply voltage	V _{CC}	2.2	V
Power dissipation	P _d	650*	mW
Operating temperature	T _{opr}	-25~+75	°C
Storage temperature	T _{stg}	-55~+125	°C

* When mounted on a 90mm × 50mm × 1.6mm glass epoxy board. Reduced by 6.5mW for each increase in Ta of 1°C over 25°C.

●Recommended operating conditions (Ta = 25°C)

Parameter	Symbol	Min.	Typ.	Max.	Unit
Power supply voltage	V _{CC}	0.9	1.25	2.0	V

●Electrical characteristics (unless otherwise noted, Ta = 25°C, V_{CC} = 1.25V, and f = 1kHz)

Parameter	Symbol	Min.	Typ.	Max.	Unit	Conditions
Quiescent current	I _Q	0.3	0.9	1.6	mA	V _{IN} =0V _{rms}
Open loop voltage gain	G _{VO}	50	65	—	dB	V _O =-20dBV
Input conversion noise voltage	V _{NIN}	—	1.2	2.0	μV _{rms}	R _g =2.2kΩ, V _{IN} =0V _{rms}
Maximum output voltage	V _{OM}	200	350	—	mV _{rms}	THD=1%
Channel separation	CS	50	60	—	dB	R _g =2.2kΩ, V _O =0.2V _{rms}
A / B crosstalk	CT _{A-B}	50	65	—	dB	R _g =2.2kΩ, V _O =0.2V _{rms}
Total harmonic distortion	THD	—	0.05	0.2	%	V _O =0.2V _{rms}
Input bias current	I _B	—	125	500	nA	V _{IN} =0V _{rms}
Metal mute level	MUTE	3.0	4.5	7.0	dB	V _O =-20dBV, f=10kHz

● Measurement circuit

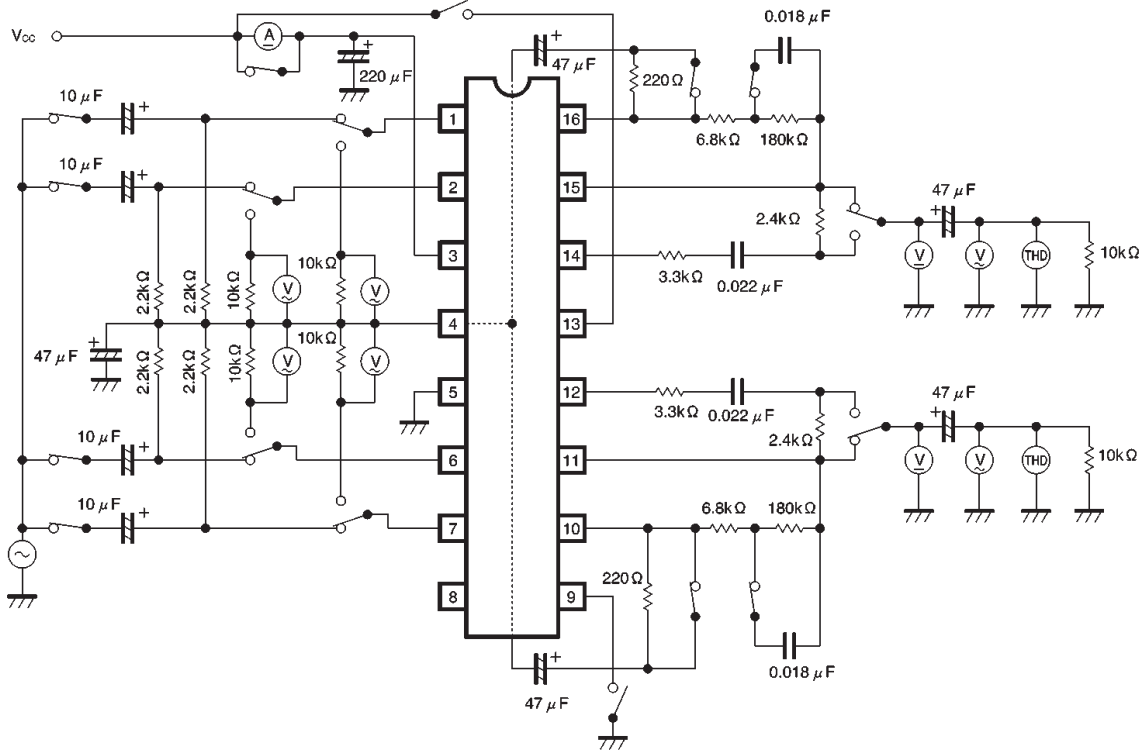

Fig.1

● Application example

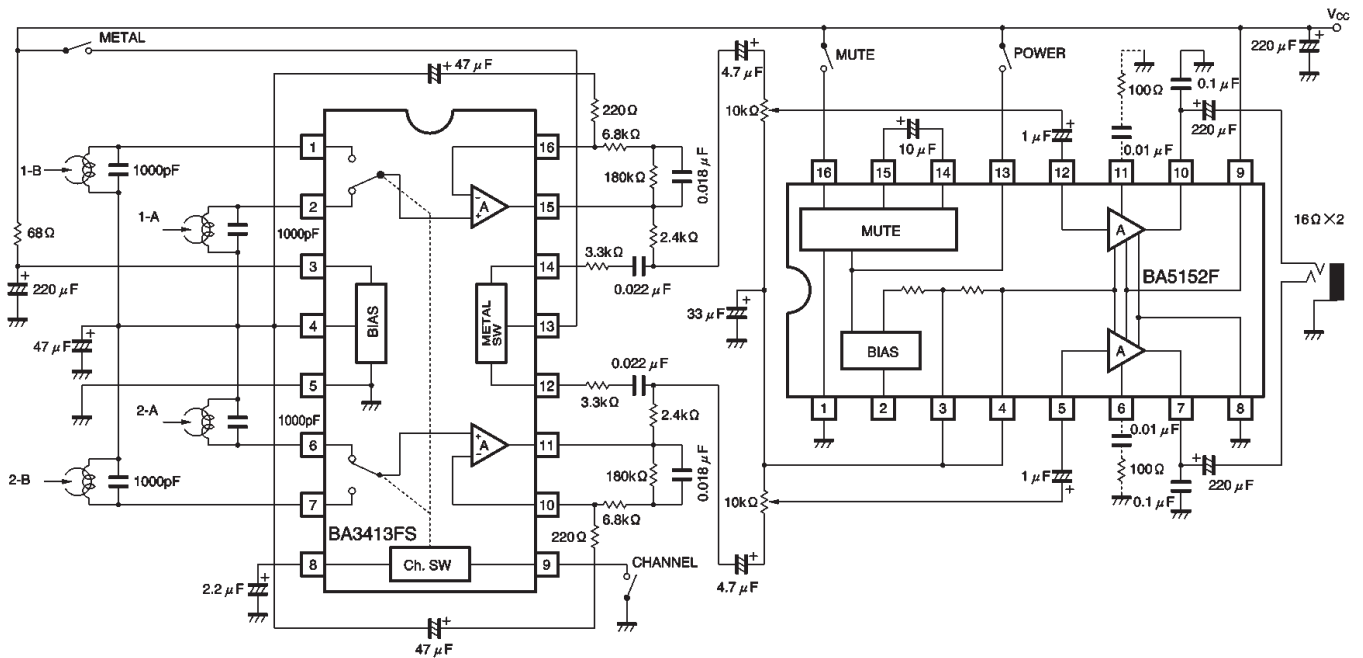

Fig.2

●Circuit operation

(1) Input stage

At the input stage the pin 4 bias is the input and the negative feedback virtual earth, and the bias for the input stage transistor is taken from pin 4. This allows direct head coupling. Connect a 1000pF capacitor in parallel with the tape head to prevent high-frequency interference.

(2) Input switching

The auto-reverse switching circuit switches the constant current supply for the first-stage transistor, and responds depending on whether pin 9 is open circuit or connected to GND. The reverse timing can be adjusted by changing the value of the capacitor connected to pin 8 (see Fig. 3).

(3) Equalizer

The equalizer is based on a NAB120μS NF-type equalizer, and has 70μS muting added for metal tape applications. The equalizer constants can be changed by switching pin 13 between open circuit and V_{CC} (see Fig. 4).

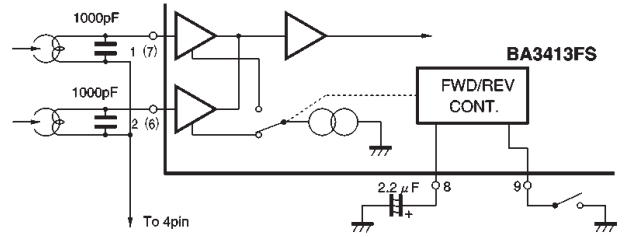

Fig. 3

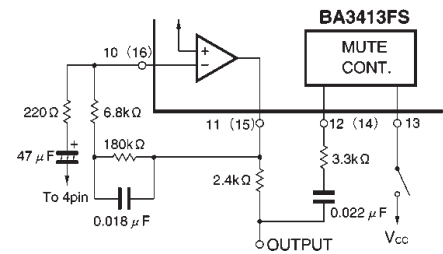

Fig. 4

●Electrical characteristics curves (Ta = 25°C)

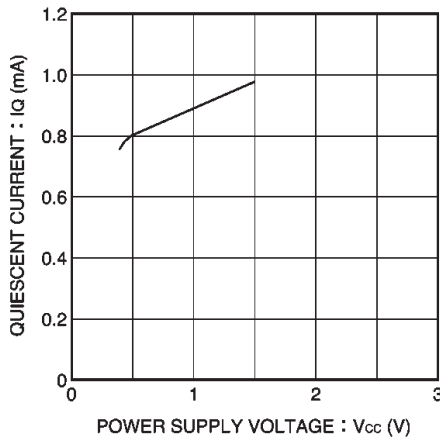

Fig. 5 Quiescent current vs. power supply voltage

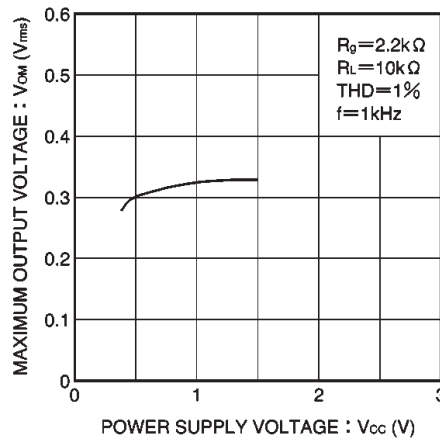

Fig. 6 Maximum output voltage vs. power supply voltage

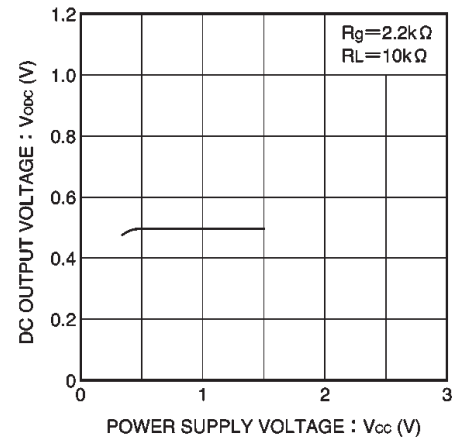

Fig. 7 DC output voltage vs. power supply voltage

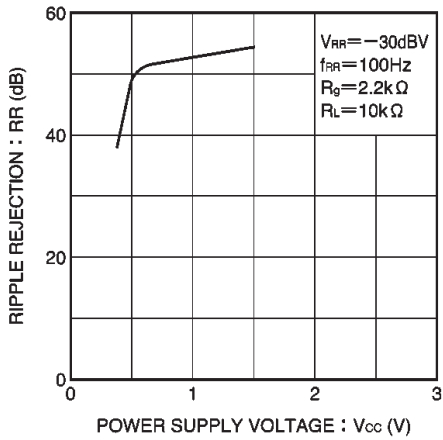

Fig. 8 Ripple rejection ratio vs. power supply voltage

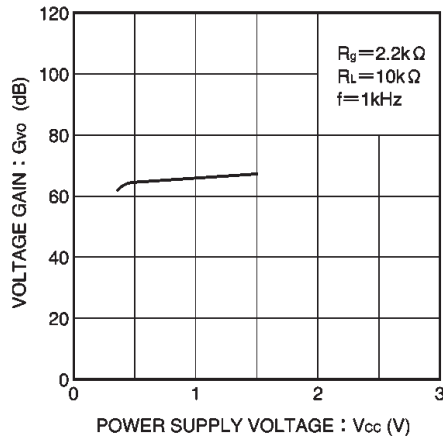

Fig. 9 Voltage gain vs. power supply voltage

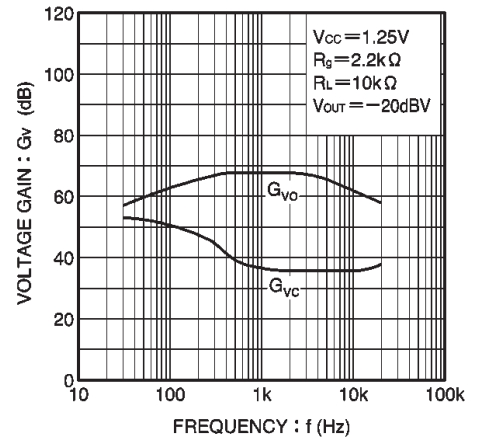

Fig. 10 Voltage gain vs. frequency

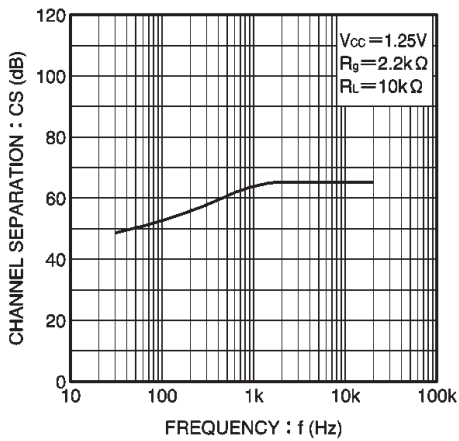

Fig. 11 Crosstalk vs. frequency

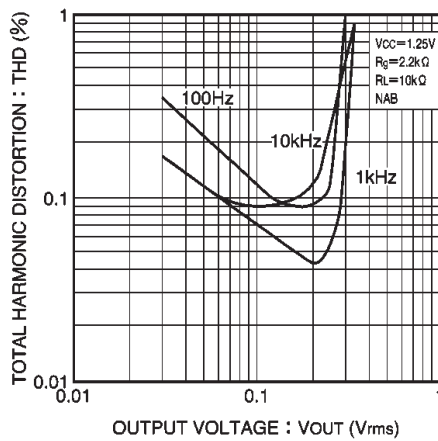

Fig. 12 Total harmonic distortion vs. output voltage

● External dimensions (Units: mm)

