

ACOUSTAR[®]

24 BIT STEREO DIRECT DRIVE DIGITAL AUDIO AMPLIFIER

SUMMARY

The ZXCW6100S28 is part of the Acoustar™ range of new generation digital audio power devices from Zetex. It has a level of performance not offered by any other solution and with minimal components forms a complete audio interface from digital audio data to the loudspeaker.

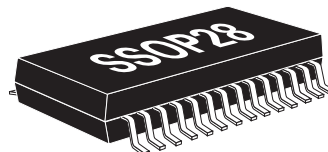

FEATURES

- Typical solution performance
 THD+N (1W into 4Ω) 0.05%
 Dynamic range 101dB
 Noise floor -110dB
- 24 Bit Conversion
- All common digital audio standards supported
- All sampling rates up to 192kHz supported
- 768 times over sampling (single speed mode)
- 16 times digital filtering (single speed mode)
- Digital De-emphasis 32,44.1,48kHz
- ATAPI mux/mute CD-ROM standard
- 3 wire SPI control interface
- ZTA filter system
- Soft Mute, digital silence
- Direct Drive PWM output
- Noise Shaper stability up to full modulation
- Effective PWM frequency up to 1MHz
- Digital Volume, Mute, Bass and Treble control
- NOVALOAD™ for clipping control
- 28 pin SSOP package

APPLICATIONS

- 5.1 Integrated DVD amplifiers
- Home theatre systems
- Mini Hi-fi
- Automotive audio
- PC audio

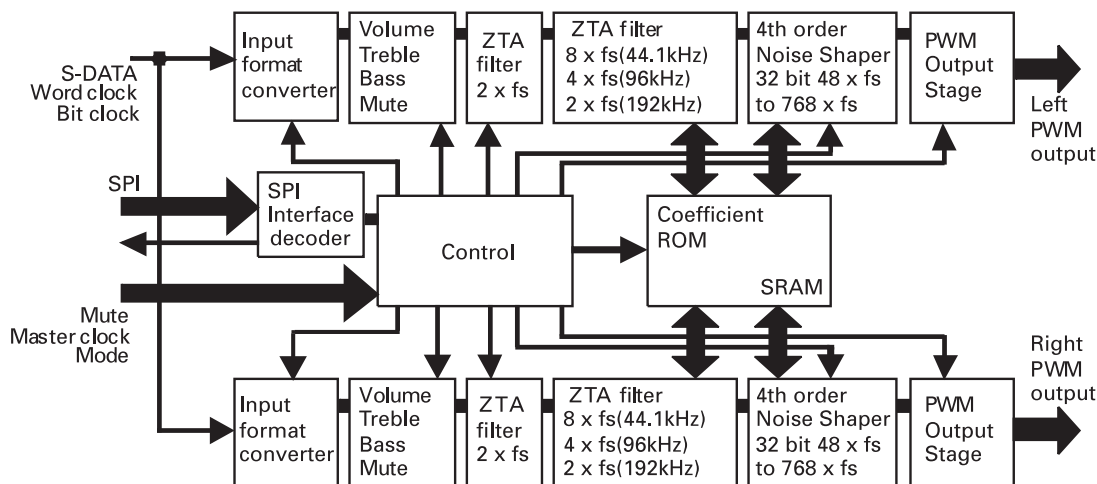

ZXCW6100S28

DESCRIPTION

The ZXCW6100 is part of a new generation of stereo digital audio power amplifier devices. The device offers a move forward to a new level of performance not offered by another solution. The ZXCW6100 operates in direct drive mode and can be selected to be with or without dead time.

Exceptional performance can be achieved with the ZXCW6100 device in direct drive mode, the dynamic range is 101dB, the noise floor sits at -110dB and when driving 1W into 4Ω THD+N is 0.05%. The device supports all common digital audio input formats.

Sampling frequencies up to 192kHz are fully supported, dependant on which sampling frequency is selected then the device can operate in single, dual or quad speed modes. In single speed mode, then the popular 44.1kHz sampling from audio CDs is oversampled up to 768 times. This results in a master clock speed of 33MHz. Digital de-emphasis is also supported as well as mixing and muting according to the ATAPI CD-ROM standard.

Other key features include user definable digital control of Volume, Mute, Bass & Treble. The device also features Zetex unique overload management system NOVALOAD™. NOVALOAD™ can operate in several ways to modify either volume, tone or both with user definable attack and decay rates. There is a hard mute available as well as a mute with digital silence, whereby the output stage is set to the quiescent state.

The device is controlled via a 3 wire SPI (Serial Peripheral Interface) interface from the host system controller. Device function control is achieved by writing an 8-bit control and 64 bit data string to internal registers within the ZXCW6100 chip. The SPI interface is bi-directional, allowing the configuration to be read back as required.

Multiple devices can easily be configured together by using the SPI enable of each ZXCW6100. This means that in 5.1 surround sound systems, for example, three ZXCW6100 devices can be configured together.

The device provides direct drive Pulse Width Modulation (PWM) 2 channel stereo outputs which, via a FET drive interface with an H Bridge output stage, forms a full solution to Digital Power Amplification. Reference designs are available for the solutions with typical power levels up to 60W.

The ZXCW6100 device operates from a 3.3V supply with an operating temperature range from -40°C to +85°C. The device is supplied in a 28 pin SSOP package.

ZXCW6100S28

ABSOLUTE MAXIMUM RATINGS

Supply voltage (V_{CC})	-0.3 to 4.0V
Digital input current	+/-20mA
Digital output current	+/-20mA
Digital input voltage	-0.3 to $V_{CC} + 0.3V$
Digital output voltage	-0.3 to $V_{CC} + 0.3V$
Package power dissipation	1.4W
Storage temperature	-55 to 125°C

Note: The Absolute Maximum Ratings indicate levels where permanent damage to the device may occur. Functional operation is not guaranteed under these conditions. Operation at any of the absolute maximum conditions for extended periods may adversely affect the long term reliability of the device.

PACKAGE CHARACTERISTICS

Thermal resistance	
θ_{JA} (junction to ambient)	49°C/W

OPERATING CONDITIONS

Symbol	Parameter	Conditions	Min	Typ	Max	Unit
V_{CC}	Supply voltage		3	3.3	3.6	V
T_O	Operating temperature range		-40		85	°C

DC ELECTRICAL CHARACTERISTICS

TEST CONDITIONS (Unless otherwise stated): $V_{CC} = 3.3V$, $T_{AMB} = 25^\circ C$

SUPPLY CHARACTERISTICS

Symbol	Parameter	Conditions	Min	Typ	Max	Unit
I_S	Static Supply current	All clocks & data static			10.5	μA
I_{DD}	Operational supply current			112	144	mA
P_D	Dissipation			380	475	mW

DIGITAL INPUT CHARACTERISTICS

Symbol	Parameter	Conditions	Min	Typ	Max	Unit
V_{IH}	High level input voltage	$V_{OUT} \geq V_{OH(min)}$ or	2		$V_{CC}+0.3$	V
V_{IL}	Low level input voltage	$V_{OUT} \leq V_{OUT(max)}$	-0.3		0.8	V
I_{IN}	Input current	$V_{IN} = 0V$ or V_{CC}			+/-0.5	μA
I_C	Input capacitance			4.7		pF

DIGITAL INPUT WITH ACTIVE PULL-UP CHARACTERISTICS

Symbol	Parameter	Conditions	Min	Typ	Max	Unit
V_{IH}	High level input voltage	$V_{OUT} \geq V_{OH(min)}$ or	2		$V_{CC}+0.3$	V
V_{IL}	Low level input voltage	$V_{OUT} \leq V_{OUT(max)}$	-0.3		0.8	V
I_{IL}	Low level Input current	$V_{IN} = 0V$		-53	-70	μA
I_{IH}	High level Input current				0.5	μA
I_C	Input capacitance			4.7		pF

ISSUE 2 - FEBRUARY 2004

ZXCW6100S28

DIGITAL INPUT WITH ACTIVE PULL-DOWN CHARACTERISTICS

Symbol	Parameter	Conditions	Min	Typ	Max	Unit
V _{IH}	High level input voltage	V _{OUT} ≥ V _{OH(min)} or V _{OUT} ≤ V _{OUT(max)}	2		V _{CC} +0.3	V
V _{IL}	Low level input voltage		-0.3		0.8	V
I _{IL}	Low level Input current	V _{IN} = V _{CC}			-0.5	μA
I _{IH}	High level Input current			60	75	μA
I _C	Input capacitance			4.7		pF

DIGITAL OUTPUT CHARACTERISTICS

Symbol	Parameter	Conditions	Min	Typ	Max	Unit
V _{OH}	High level output voltage	V _{CC} = 3V, or I _{OH} = -12mA	2.4			V
V _{OL}	Low level output voltage	V _{CC} = 3V, or I _{OL} = 12mA			0.4	V

DIGITAL IO CHARACTERISTICS

Symbol	Parameter	Conditions	Min	Typ	Max	Unit
V _{IH}	High level input voltage	V _{OUT} ≥ V _{OH(min)} or V _{OUT} ≤ V _{OUT(max)}	2		V _{CC} +0.3	V
V _{IL}	Low level input voltage		-0.3		0.8	V
I _{IN}	Input current	V _{IN} = 0V or V _{CC}			+/-0.5	μA
I _C	Input capacitance			4.71		pF
V _{OH}	High level output voltage	V _{CC} = 3V, or I _{OH} = -8mA	2.4			V
V _{OL}	Low level output voltage	V _{CC} = 3V, or I _{OL} = 8mA			0.4	V

AC ELECTRICAL CHARACTERISTICS

TEST CONDITIONS (Unless otherwise stated): V_{CC} = 3.3V, T_{AMB} = 25°C

MASTER CLOCK

Symbol	Parameter	Conditions	Min	Typ	Max	Unit
M _{CK}	Clock frequency			33.8688	40	MHz
M _{MS}	Mark to space ratio		40:60		60:40	%

ZXCW6100S28

SWITCHING CHARACTERISTICS: SPI INTERFACE - WRITE

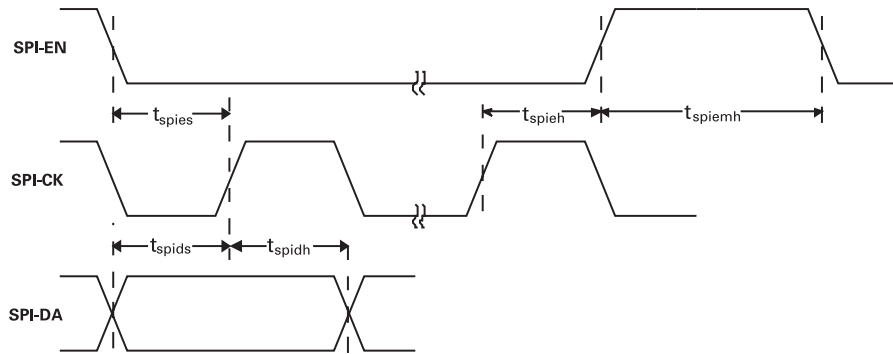

Symbol	Parameter	Conditions	Min	Typ	Max	Unit
S_{CK}	SPI-CK clock frequency			$M_{CK}/8$	40	MHz
t_{spids}	SPI-DA set-up time		0.5			ns
t_{spidh}	SPI-DA hold time		0.1			ns
t_{spies}	SPI-EN hold time		0.7			ns
t_{spieh}	SPI-EN hold time		0.1			ns
t_{spiemh}	SPI-EN minimum high time		3			M-CK ¹

Note: ¹ M-CK = Master Clock Cycles.

SWITCHING CHARACTERISTICS: SPI INTERFACE - READ

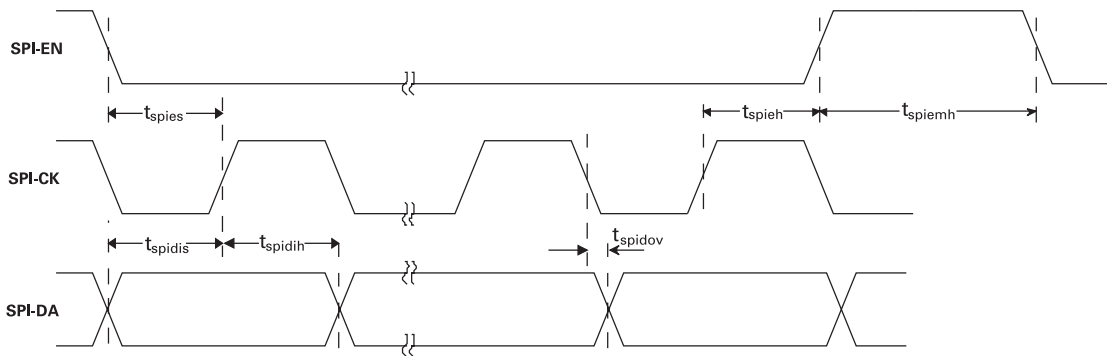

Symbol	Parameter	Conditions	Min	Typ	Max	Unit
S_{CK}	SPI-CK clock frequency				40	MHz
t_{spids}	SPI-DA set-up time		0.5			ns
t_{spidh}	SPI-DA Data hold time		0.1			ns
t_{spidov}	time to valid SPI-DA data out	Load capacitance (C_L) = 50pf			2.1	ns
t_{spies}	SPI-EN hold time		0.7			ns
t_{spieh}	SPI-EN hold time		0.1			ns
t_{spiemh}	SPI-EN minimum high time		3			M-CK ¹

Note: ¹ M-CK = Master Clock Cycles.

ISSUE 2 - FEBRUARY 2004



ZXCW6100S28

SWITCHING CHARACTERISTICS: AUDIO INPUT DATA

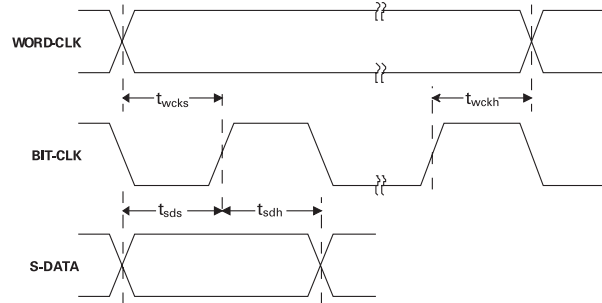

Symbol	Parameter	Conditions	Min	Typ	Max	Unit
B _{CK}	BIT-CK clock frequency			M _{CK} /8	40	MHz
t _{sds}	S-DATA set-up time		1			M-CK ¹
t _{sph}	S-DATA hold time		1			M-CK ¹
t _{wcks}	WORD-CLK set-up time		1			M-CK ¹
t _{wckh}	WORD-CLK hold time		1			M-CK ¹

Note: ¹ M-CK = Master Clock Cycles.

MASTER CLOCK TO PWM OUTPUT CHARACTERISTICS

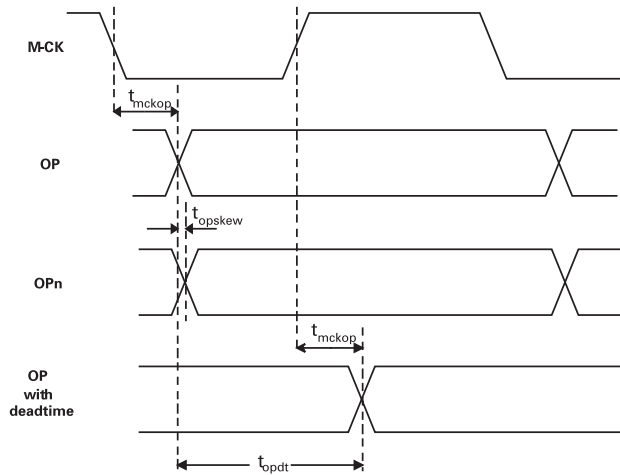

Symbol	Parameter	Conditions	Min	Typ	Max	Unit
t _{mckop}	M-CK to PWM output delay			3.0		ns
t _{opskew}	PWM output to output skew			250		ps
t _{spdt}	PWM output to deadband output time			14.8		ns ²

Note: ² This translates to the low period of the Master Clock (M-Cl) cycles.

ZXCW6100S28

TYPICAL CHARACTERISTICS

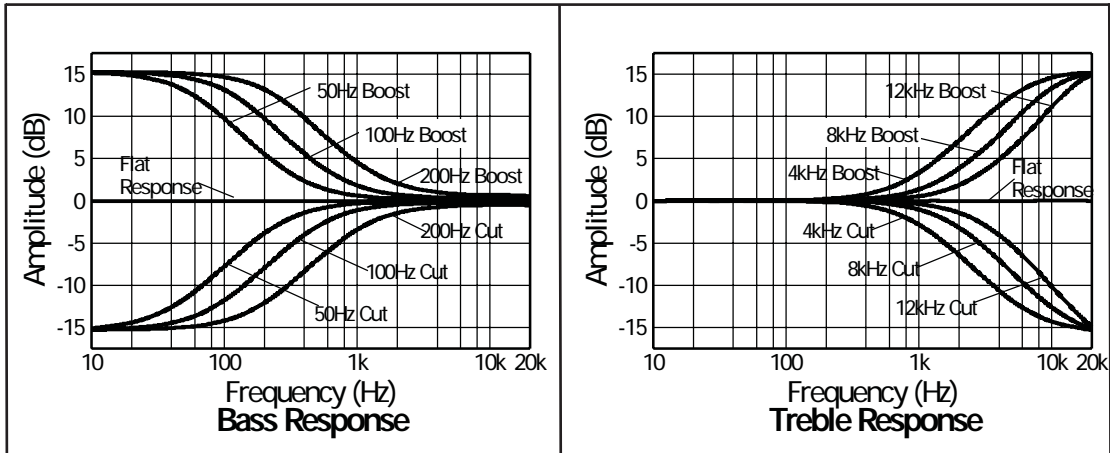

ZXCW6100S28

PINOUT DIAGRAM

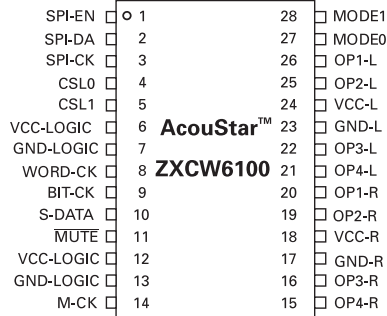

PIN DESCRIPTIONS

Pin	Name	Type	Description
1	SPI-EN	LVTTTL IP	SPI interface enable, active low
2	SPI-DA	LVTTTL I/O	SPI data
3	SPI-CK	LVTTTL IP	SPI clock
4	CSLO	LVTTTL IP+PU	Connect to logic Gnd
5	CSL1	LVTTTL IP+PU	Connect to logic Gnd
6	VCC-LOGIC		Core logic supply voltage, 3.3V
7	GND-LOGIC		Core logic ground
8	WORD-CK	LVTTTL IP	Digital audio word clock, matches to system sampling rate
9	BIT-CK	LVTTTL IP	Digital audio bit clock
10	S-DATA	LVTTTL IP	Serial digital audio data input
11	MUTE	LVTTTL IP+PU	Mute enable, active low
12	VCC-LOGIC		Core Logic supply, 3.3V
13	GND-LOGIC		Core Logic ground
14	M-CK	LVTTTL IP	System master clock
15	OP4-R	LVTTTL OP	Right channel PWM drive output, see applications section
16	OP3-R	LVTTTL OP	Right channel PWM drive output, see applications section
17	GND-R		Right channel PWM drive output ground
18	VCC-R		Right channel PWM drive output supply, 3.3V
19	OP2-R	LVTTTL OP	Right channel PWM drive output, see applications section
20	OP1-R	LVTTTL OP	Right channel PWM drive output, see applications section
21	OP4-L	LVTTTL OP	Left channel PWM drive output, see applications section
22	OP3-L	LVTTTL OP	Left channel PWM drive output, see applications section
23	GND-L		Left channel PWM drive output ground
24	VCC-L		Left channel PWM drive output supply, 3.3V
25	OP2-L	LVTTTL OP	Left channel PWM drive output, see applications section
26	OP1-L	LVTTTL OP	Left channel PWM drive output, see applications section
27	MODE0	LVTTTL IP+PU	Mode select, direct drive with or without dead time
28	MODE1	LVTTTL IP+PD	Connect to Gnd

Note +PU = with Pull-up Device

+PD = with Pull-down Device



ISSUE 2 - FEBRUARY 2004

ZXCW6100S28

BLOCK DIAGRAM

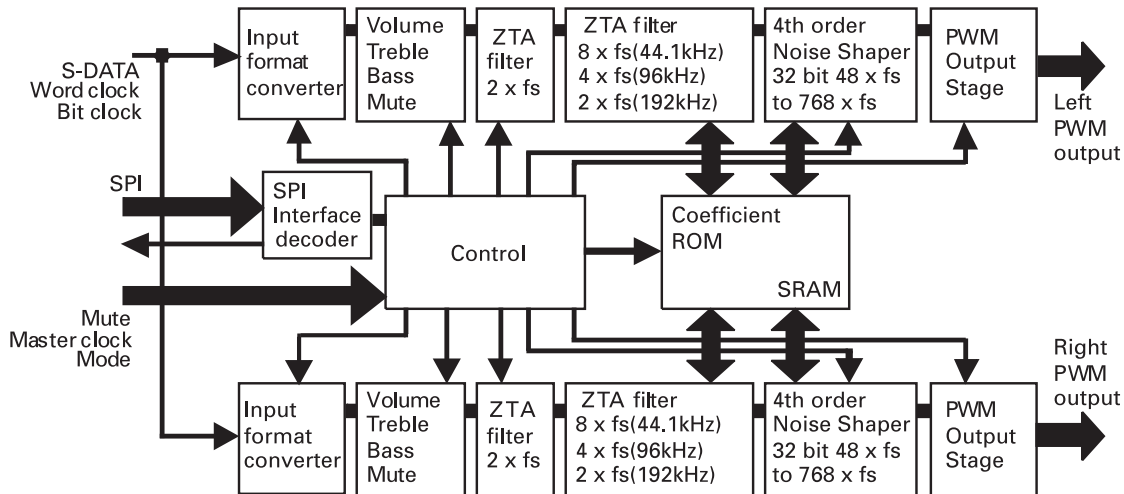

FUNCTIONAL DEVICE DESCRIPTION

The ZXCW6100 device is an integrated stereo digital amplifier. It takes in digital audio data, in any of the common digital audio formats, processes it and delivers a PWM direct drive left and right channel output. The direct drive PWM output stage can be used to drive full bridge tied load output stages configured to deliver typical power in the range 10W to 50W and above.

SPI Interface

The device is controlled by a 3 wire SPI interface. The 8 bit control and 64 bit data words directed through the SPI interface are used to control all the functions of the ZXCW6100 device:

- Chip address
- Volume/Mute
- Bass/Treble
- De-emphasis
- NOVALOAD™
- Audio data format
- ATAPI CD-ROM standard
- PWM drive outputs
- Auto power low
- Speed mode

The SPI interface is bi-directional such that the appropriate programmed configuration and data can be read back if required.

ISSUE 2 - FEBRUARY 2004

Format converter

The format converter ensures the device is compatible with all the normal digital input standards. The standards supported are:

- 24 bit I²S
- Left justify 24 bit
- Right justify 16 bit
- Right justify 24 bit

The audio data for left and right channels is transmitted in the high and low periods of the word clock depending on the format chosen. The first received audio data is held until the corresponding channel data is received. The left and right channels data are then processed in parallel. The word clock represents the sampling rate of the audio data input, also referred to as Fs.

Volume

Digital volume control is achieved through the SPI port. Volume can be set anywhere in the range of -94.5dB to +25dB in 0.5dB steps. A code is included in the volume register to enable a soft mute function to be achieved, this set to -95dB.

A digital silence function is also available, this is selected by activating the auto low power mode. In this case, if no serial digital data is detected for a period of 4096 word clocks then the output stage is switched off. In this mode minimum EMC signature is experienced.

ZXCW6100S28

Bass

The bass control can be set to a selection of corner frequencies:

50Hz
100Hz
1200Hz

These corner frequencies are stated for a nominal 44.1kHz sampling frequency. If the sampling frequency is altered then the corner frequency is automatically adjusted. Once selected then the bass control can be set to either cut or boost with gain from 0dB up to 15dB in 1dB steps.

Treble

The treble control can be set to a selection of corner frequencies:

4kHz
8kHz
12kHz

These corner frequencies are stated for a nominal 44.1kHz sampling frequency. If the sampling frequency is altered then the corner frequency is automatically adjusted. Once selected then the treble control can be set to either cut or boost with gain from 0dB up to 15dB in 1dB steps.

Master clock

Essential to the performance of the system is the provision of a low jitter clock to the ZXCW6100 device, a jitter of less than +/-1ns is required. As well as low jitter the master clock needs to be a consistent mark to space ratio. This master clock is generated from the external audio system, consistency needs to be better than 3ns with a 33MHz master clock.

The relationship between the master clock and the word clock provided with the audio data input determines the device speed and oversampling rate for the ZTA filters and the Noise shaper/PWM drive. The master clock is a nominal 33.8688MHz for a 44.1kHz fs (sampling rate) with 768 times oversampling.

Sampling Rates

The ZXCW6100 device supports a wide range of sampling rates depending on the media being played. Typically as follows:

Single speed	32kHz, 44.1kHz, 48kHz
Dual speed	88.2kHz, 96kHz
Quad speed	176.4kHz, 192kHz

ZTA filters

The ZTA filters use the proprietary ZTA algorithm to perform up to 48 times digital filtering. The speed mode of the device selects the oversampling performed:

Single speed	16 times
Dual speed	8 times
Quad speed	4 times

In addition to providing state of the art out of band noise performance, the ZTA filter gives superior transient resolution, which improves sound stage imaging, timing, focus and bass definition.

Noise shaper & PWM drive

The noise shaper effectively offers continuous feedback to the system. It enables removal of any dead time distortion and enables the drive to the PWM FET switching. Switching distortions are also removed by the noise shaper.

The PWM output converts the noise shaper output into four PWM drive lines per channel. These output lines, suitably buffered, drive a full MOSFET H bridge. The output is configured as a bridge tied load. Each of the four output lines drives N and P channel MOSFET pairs. The effective PWM frequency is 1MHz, significantly faster than alternative solutions. This high frequency allows for greater resolution and enables lower noise and distortion figures to be achieved. The PWM output can be utilised either with or without dead time enabled.

Two different modulation schemes are available, known as HPWM and RPWM, these two schemes have different strengths that the user can take advantage of as they are selectable through the SPI interface. Accompanying the two PWM schemes is the ability to select one of two switching frequencies to help attain the best performance from the PWM scheme and output stage combination.

HPWM is a conventional digital PWM strategy that is to be found in current applications. The frequency of operation is 1.058MHz, derived from 24 times the 44.1kHz sampling frequency.

HPWM provides a lower level of overall RF noise in the AM band with that noise concentrated on multiples of the switching frequency. With very careful OP stage design it is capable of the best measured dynamic range.

ZXCW6100S28

RPWM is a proprietary PWM scheme that applies different data to both sides of a conventional H bridge output stage. The primary purpose of this is to maximise the resolution of the internal noise shaper. This doubles the noise shaper resolution. The other advantage of RPWM is that the FET switching frequency is halved. RPM therefore can have two speeds of 529kHz and 1.058MHz. This lower speed does not reduce the noise shaper performance.

The nature of RPWM also ensures that it is less susceptible to correlated jitter on the master clock resulting in a better signal to noise ratio with jittery clocks.

The recommended mode of operation for new users is HPWM.

Chip select

It is possible to cascade several ZXCW6100 devices for multi-channel applications. Each chip is accessed using the appropriate SPI enable line. Valid data for the individual ZXCW6100 is clocked in during SPI enable low periods. SPI data and clock can be common. A separate enable line per device is required.

Mute

A hard mute facility is provided for the device when used in direct drive mode. Active low, this control will shut off the output drive. Once released, the output will remain disabled for approximately 0.5 seconds. Additionally this facility can be used to provide thermal and current overload protection.

Mode

The direct drive ZXCW6100 device can be operated in different modes. In the configuration provided, the device can operate with or without dead time depending on the selection of output drive characteristics. The direct drive ZXCW6100 device can be selected through external input pins to operate with or without dead time. It is recommended to run the device without dead time.

Full details about the use of these modes is available in the associated Application document. Contact your nearest Zetex office for full details.

Supplies

The device is provided with several power supply connections. A nominal 3.3 volt supply is required with the supply pairs being de-coupled separately and as close to the device as possible.

NOVALOAD™

The NOVALOAD™ system provides a mechanism for overload control. It can operate in several different ways as it acts to back off the gain of the volume or bass blocks. Once activated there are two modes of operation available for the user to select. With the NOVALOAD™ Mode register bit NOVLM = 1 any overload in the volume circuit block will result in the gain of the volume block being reduced and if any overload takes place in the bass circuit block then the volume is again reduced keeping the bass boost unaffected. With the NOVLM = 0 any overload in the volume block will result in the gain of the volume block being reduced, however, if any overload is present due to bass boost the bass boost is removed completely. When no bass clipping has occurred for a period of time greater than that set by the limiter release rate register (but not greater than two times that period) the bass boost is fully restored to its previous level as determined by the bass gain register.

The rate at which the volume is reduced in response to clipping can be programmed through the SPI interface. The gain reduces by 0.5dB over a selected number of word clock periods. Typically this will be set to 0.5dB in 4 word clocks. Once the overload condition is removed then the gain is released to increase again. This is also programmable as 0.5dB per selected number of word clocks. Typically this will be set to 0.5dB per 16 word clock periods.

The release rate coming out of NOVALOAD™ is critical to a good sound. Typically 2 seconds is suggested for pop and rock, 4 to 8 seconds for classical.

De-emphasis

De-emphasis is activated when older audio recordings are used in the system. These will have used pre-emphasis to achieve noise reduction. The de-emphasis frequency response curve is selected versus the system sampling rate. De-emphasis only applies in single speed mode.

ZXCW6100S28

PIN FUNCTIONAL DESCRIPTIONS

SPI interface

Pins SPI-EN, SPI-DA, SPI-CK form the SPI interface. The enable, SPI-EN, is active low. Data is transmitted on SPI-DA as a 72 bit word, there are 8 control bits and 64 data bits, SPI-CK provides the clock for the SPI interface. The function of the control and data bits is detailed in the Register Description section. The SPI interface is also bi-directional with the read/write function set in the first 8 control bits.

In write mode (figure 1) a full 72 bits is sent from the host controller consisting of the 8 preamble control bits with the R/W bit set low and the 64 SPI data bits. The SPI-EN signal must be held low, enabled, for all 72 clocks and data bits as a validity check is run on the incoming data string and any string not 72 bit long is rejected. It is recommended to perform a read back of the SPI data registers to validate the receipt of the correct instruction.

In read mode (figure 2) the host controller sends the first 8 preamble control bits with the R/W bit set high. The SPI-DA pin of the ZXCW6100 device changes state from being an input to being an output on the falling edge following the R/W bit. The device then reads out the data from the internal SPI register onto the SPI-DA wire.

Data can be sent to SPI interface using two methods - burst mode or continuous mode. In burst mode data will be sent as a single 72 bit SPI data word accompanied by 72 SPI-CK clock bits. This data would be sent as and when operating parameters are required to be changed.

In continuous mode the SPI-CK clock will run continuously with the SPI-DA data being resent regardless of whether operating parameters are required to be changed or not. The only requirement for this mode, or for burst mode, as regard the frequency of SPI update is that the SPI-EN enable line is returned high for a minimum of 3 M-CK master clock cycles between SPI data words.

The SPI interface can operate asynchronously to the M-CK master clock and to any other data inputs. It can run up to a maximum of 40 MHz however, it is expected that one eighth the M-CK clock frequency would be normal for most requirements.

SPI Interface - Write Mode (figure 1)

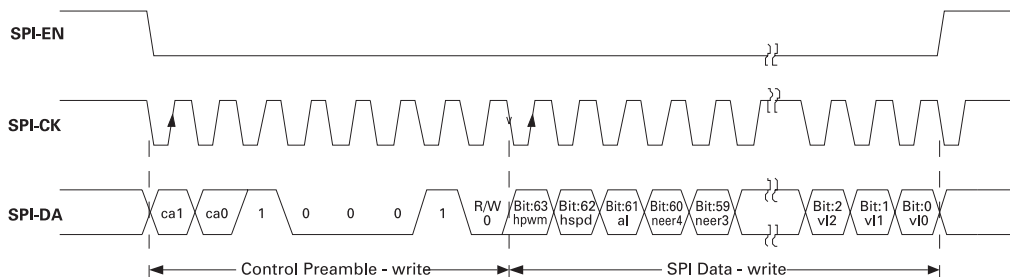

SPI Interface - Read Mode (figure 2)

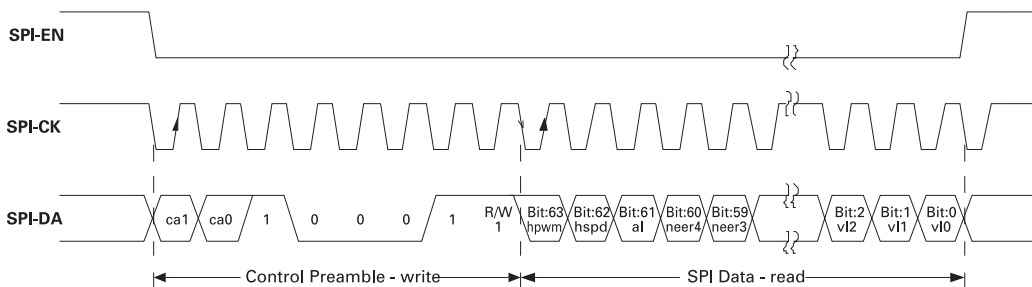

ZXCW6100S28

Audio input data

The audio input utilises three pins, WORD-CK, BIT-CK and S-DATA. The diagrams below indicate the appropriate timing diagrams for the 4 possible input formats.

Left Justify 24 bit

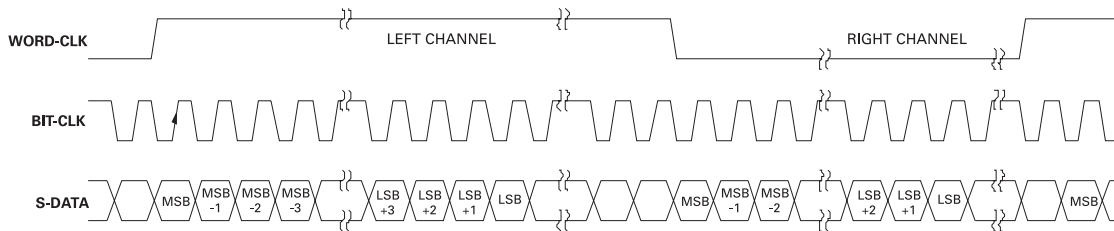

24 bit I²S Compatible

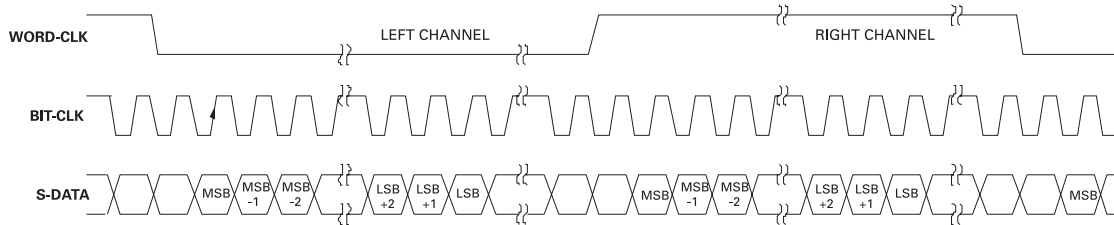

Right Justify 16 or 24 bit

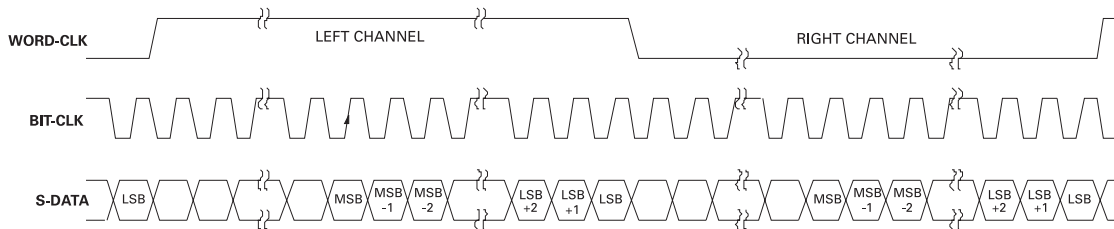

ZXCW6100S28

Mute

Mute is enabled with the MUTE pin. Mute is active low.

Master clock

The system master clock is applied to pin M-CK

Output drive

Output drive is provided on 8 pins, 4 each for left and right. For each channel the pins are OP1 to OP4 then L or R. OP1 and OP2 as a pair drive the gates of an N & P channel MOSFET pair through a gate drive buffer that includes dead time control. OP3 and OP4 drive a similar pair. These pairs in turn drive a BTL (bridge tied load) loudspeaker – see the Typical Applications Diagram for details. Timing diagrams are shown in the AC Characteristics section.

Operating mode	MODE0 pin	MODE1 pin
Direct drive no dead time	0	0
Direct drive with dead time	1	0

Mode (dead/no dead time)

MODE0 and MODE1 are used to set the operating mode of the ZXCW6100 device. There are two modes available, direct drive with and without dead time.

Without dead time the output stage on and off switching to the N and P channel MOSFETs occurs at the same time. The user can then design any dead time or cross conduction into the output stage as required by the characteristics of the MOSFET being used.

When dead time is selected a delay is introduced between the N and P channel MOSFET switching such that the active MOSFET is switched off before the inactive MOSFET is switched on. This is particularly useful where MOSFETs have a slow turn off time and might otherwise give a large amount of cross conduction in the N and P channel MOSFET pair.

Dead time is a function of the master clock frequency and is effectively a half the master clock rate. For the nominal 33MHz master clock, dead time is therefore approximately 15ns.

Whilst this digital dead time is available it is recommended for most applications that shorter periods of dead time are used by including dead time control within the FET drive buffer circuit.

SPI REGISTER SUMMARY

The following indicates the general structure of the 72 bit SPI word used for control and data.

Control

SPI preamble: ca1 ca0 1 00011 read
 ca1 ca0 1 00010 write

Bits ca1 and ca0 should be set low. The next 4 bits are a silicon reference to the ZXCW6100 part number. The other two bits determine if the SPI interface is in read or write modes.

ZXCW6100S28

SPI bi-directional interface register

The interface control register defines the functionality of the device. It is a 64 bit register. Bit 64 is read as the MSB, bit 0 is the LSB, MSB stated first. The default setting is 0 except where stated.

Bit No.	Function	Bit Identifier	Comments/Example	
0	volume left	vl0	vl8.....vl0	
1		vl1		
2		vl2		011111110 is 0dB
3		vl3		100110000 is +25 dB
4		vl4		001000001 is -94.5dB
5		vl5		001000000 = soft mute
6		vl6		011111010 is default power up, -2 dB
7		vl7		See volume code tables
8		vl8		
9	volume right	vr0	vr8.....vr0	
10		vr1		
11		vr2		011111110 is 0dB
12		vr3		100110000 is +25 dB
13		vr4		001000001 is -94.5dB
14		vr5		001000000 = soft mute
15		vr6		011111010 is default power up, -2 dB
16		vr7		See volume code tables
17		vr8		
18	bass boost	bb	1 = bass boost, 0 = bass cut	
19	bass gain	bg0	bg = 1111 gives +/- 15dB bg = 0000 gives +/- 0dB See bass code table	
20		bg1		
21		bg2		
22		bg3		
23	bass freq	bf0	bf = 00: 50Hz, bf = 01: 100 Hz, bf = 10: 1.2kHz	
24		bf1		
25	treble boost	tb	1 = treble boost, 0 = treble cut	
26	treble gain	tg0	tg = 1111 gives +/- 15dB tg = 0000 gives +/- 0dB See treble code table	
27		tg1		
28		tg2		
29		tg3		
30	treble freq	tf0	tf = 00: 4kHz, tf = 01: 8kHz, tf = 10: 12kHz	
31		tf1		

ZXCW6100S28

SPI bi-directional interface register (cont)

Bit No.	Function	Bit Identifier	Comments/Example
32	50/15 μ s standard de-emphasis	de0	de = 00: none, de = 01: 44.1kHz
33		de1	de = 10: 32kHz, de = 11: 48kHz
34	novaload	novl	0 = disable, 1 = enable
35	novaload mode	novlm	0 adjust vol if vol clips, remove bass if bass clips 1 adjust vol if vol clips, adjust vol if bass clips
36	dc dither	dcadd	1= dc dither on
37	limiter attack rate	lar0	adjusts how quickly the volume is reduced during a clip
38		lar1	see attack code table
39		lar2	default 001, 0.5 ms per -3dB
40	limiter release rate	lrr0	adjusts how quickly the volume is increased after a clip see release code table default 1010, 2 sec per +3dB
41		lrr1	
42		lrr2	
43		lrr3	
44	digital interface	dif0	dif = 00: I ² S, dif = 01: left justified,
45		dif1	dif = 10: right just 16 bit, dif = 11: right just 24 bit.
46	ATAPI mix	ATI0	Hard mute, mono and channel switch see ATAPI select tables 1001 default
47		ATI1	
48		ATI2	
49		ATI3	
50	H-bridge on	hbon	hbon = 0: bridge off, hbon = 1 bridge on in direct drive mode, default=0
51	P-channel compensation	peer0	P error default: 10000 P-channel switching compensation Valid range: 00000-10000
52		peer1	
53		peer2	
54		peer3	
55		peer4	
56	N-channel compensation	neer0	N error default: 00000 N channel switching compensation Valid range: 00000-10000
57		neer1	
58		neer2	
59		neer3	
60		neer4	
61	auto low power	al	auto low power mode al = 0: disabled, al = 1: enabled
62	set speed & pwm combination	hspd	Low speed = 0 High speed = 1
63		hpwm	hpwm = 1 rpwm = 0

ZXCW6100S28

SPI REGISTER DETAILED DESCRIPTION

Volume

The volume register increments digitally in 0.5dB steps. The volume range is from -94.5dB to +25dB. The final used code in the sequence it termed a soft mute and sets the volume to -95dB. The code sequence applies equally to left and right volume controls. The bit numbers for the volume controls are 0 to 8 for the left channel and 9 to 17 for the right.

The control of the volume should not jump directly from one level to the next but should pass through all 0.5dB steps between the two required levels.

Code examples in the sequence follow:

100110000	=	25dB
100101111	=	24.5dB
100101110	=	24dB

011111111	=	0.5dB
011111110	=	0dB
011111101	=	-0.5dB

011111010	=	-2dB
-----------	---	------

(default and start up)

001000010	=	-94dB
001000001	=	-94.5dB
001000000	=	-95dB

(-95dB is the soft mute)

Bass

The bass register increments digitally in steps of 1dB. The range is from 0dB to +/-15dB depending on whether the bass control is set to cut or boost (bit18). The bit numbers for the bass level control are 19 to 22.

Bit18: boost=1, cut=0

Code examples in the sequence follow:

0000	=	+/-0dB
0001	=	+/-1dB

1110	=	+/-14dB
1111	=	+/-15dB

The bass corner frequency is selected by bits 23 and 24.

00	=	50Hz
01	=	100Hz
10	=	200Hz

Treble

The treble register increments digitally in steps of 1dB. The range is from 0dB to +/-15dB depending on whether the treble control is set to cut or boost (bit25). The bit numbers for the treble level control are 26 to 29.

Bit25: boost=1, cut=0

Code examples in the sequence follow:

0000	=	+/-0dB
0001	=	+/-1dB

1110	=	+/-14dB
1111	=	+/-15dB

The treble corner frequency is selected by bits 30 & 31.

00	=	4kHz
01	=	8kHz
10	=	12kHz

50/15µs Standard De-emphasis

The ZXCW6100 incorporates a standard 50/15µs digital de-emphasis filter. De-emphasis is applicable in single speed mode only.

Bits 32 and 33 match to sampling frequencies as below:

00	=	no de-emphasis
01	=	44.1kHz
10	=	32kHz
11	=	48kHz

ZXCW6100S28

DC Dither

A function is provided to help eliminate small signal digital zero point switching distortion by the addition of a small DC voltage. This is intended to move the signal away from the DAC zero to prevent the distortion that is sometimes discernible when the DAC switches around zero.

DC Dither would be required when using the recommended HPWM mode. If using RPWM DC dither would not normally be set, however, the requirement is application dependant and full details on use are available in the associated Application document. Contact your nearest Zetex office for full details.

Bit 36: 0 = DC dither off, 1 = DC dither on

Digital interface select

Bits 44 and 45 select the digital interface standard required as below:

00	24 bit I ² S
01	Left justify 24 or 32 bit
10	Right justify 16 bit
11	Right justify 24 bit

NOVALOAD™

NOVALOAD™ is selected using bits 34 and 35 as below:

Bit 34: 0 = NOVALOAD™ off, 1 = NOVALOAD™ on

Bit 35: 0 = remove bass control if bass clips,
1 = adjust volume control if bass clips

NOVALOAD™ limiter attack rate

The limiter attack rate is governed by bits 36 to 39. The code chosen sets the number of word clock periods to reduce the gain by 0.5dB. The number of word clock periods quadruples per digital increment.

Code sequence follow:

000	=	1 word clock period per 0.5dB
001	=	4 word clock periods per 0.5dB
010	=	16 word clock periods per 0.5dB
011	=	64 word clock periods per 0.5dB
100	=	256 word clock periods per 0.5dB
101	=	1024 word clock periods per 0.5dB
110	=	4096 word clock periods per 0.5dB
111	=	16384 word clock periods per 0.5dB

The default condition is 0010 which is 4 word clock periods.

NOVALOAD™ limiter release rate

The limiter release rate is governed by bits 40 to 43. The code chosen sets the number of word clock periods to reduce the gain by 0.5dB. The number of word clock periods doubles per digital increment

Code examples in the sequence follow:

0000	=	16 word clock periods per 0.5dB
0001	=	32 word clock periods per 0.5dB
0010	=	64 word clock periods per 0.5dB
1110	=	262144 word clock periods per 0.5dB
1111	=	524288 word clock periods per 0.5dB

The default condition is 1010 which is 16384 word clock periods.

ATAPI

The ATAPI CD-ROM standard for mixing and muting is supported by bits 46 to 49. The following logic table defines how the left and right channels are affected by the codes set on these bits:

ATI3	ATI2	ATI1	ATI0	L channel	R channel
0	0	0	0	MUTE	MUTE
0	0	0	1	MUTE	R
0	0	1	0	MUTE	L
0	0	1	1	MUTE	{{(L+R)/2}}
0	1	0	0	R	MUTE
0	1	0	1	R	R
0	1	1	0	R	L
0	1	1	1	R	{{(L+R)/2}}
1	0	0	0	L	MUTE
1	0	0	1	L	R
1	0	1	0	L	L
1	0	1	1	L	{{(L+R)/2}}
1	1	0	0	{{(L+R)/2}}	MUTE
1	1	0	1	{{(L+R)/2}}	R
1	1	1	0	{{(L+R)/2}}	L
1	1	1	1	{{(L+R)/2}}	{{(L+R)/2}}

The default setting is 1001 which is left channel = L, right channel = R



ZXCW6100S28

TYPICAL CONNECTION DIAGRAM

The following shows a typical connection diagram for the output circuit of one channel of the ZXCW6100 device. For dedicated Applications Notes please contact your nearest Zetex office.

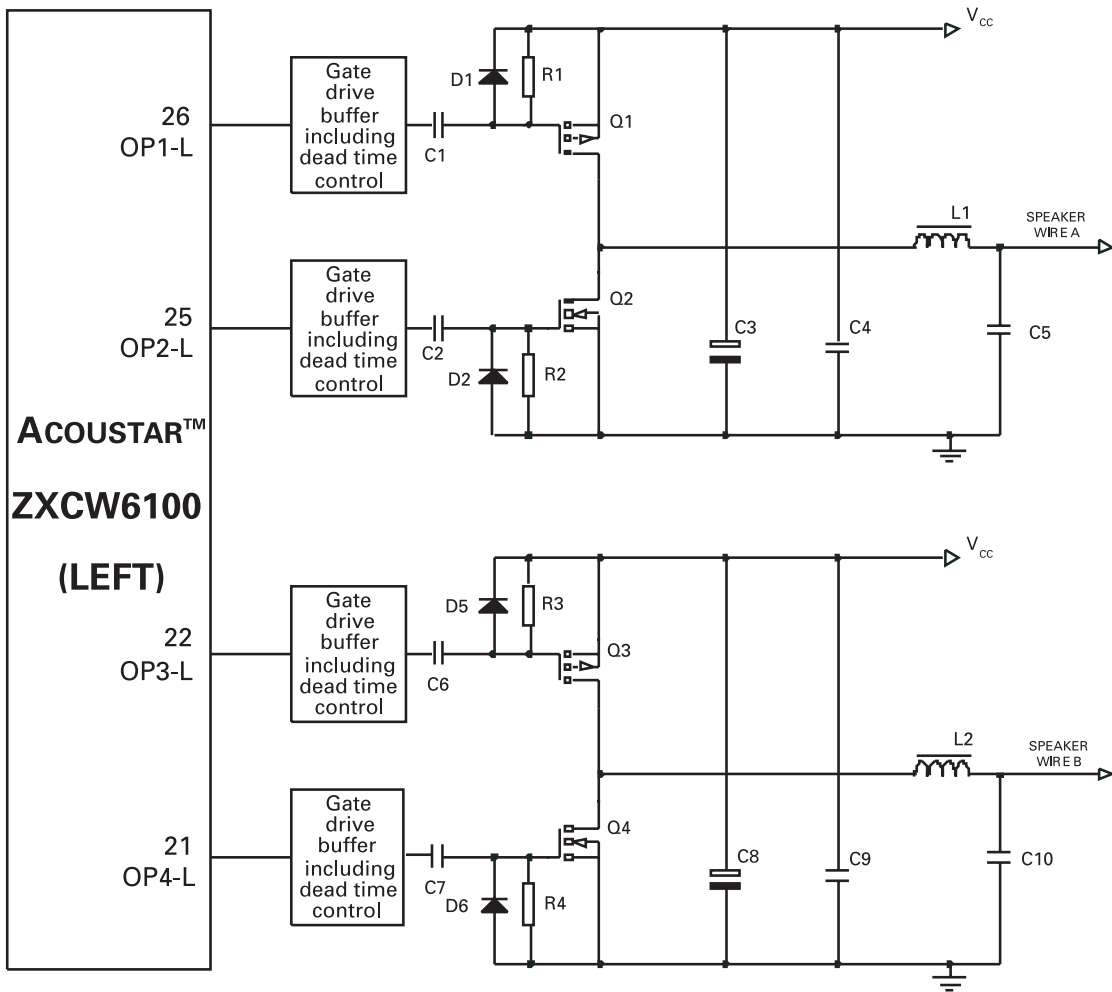

TYPICAL PERFORMANCE CHARACTERISTICS

Parameter	Conditions	Min	Typ	Max	Unit
THD+N	HPWM 1W		0.05		%
Dynamic range			101		dB
Noise floor			-110		dB

ZXCW6100S28

ISSUE 2 - FEBRUARY 2004

21



ZXCW6100S28



ISSUE 2 - FEBRUARY 2004

ZXCW6100S28

ISSUE 2 - FEBRUARY 2004

23



ZXCW6100S28

PACKAGE OUTLINE

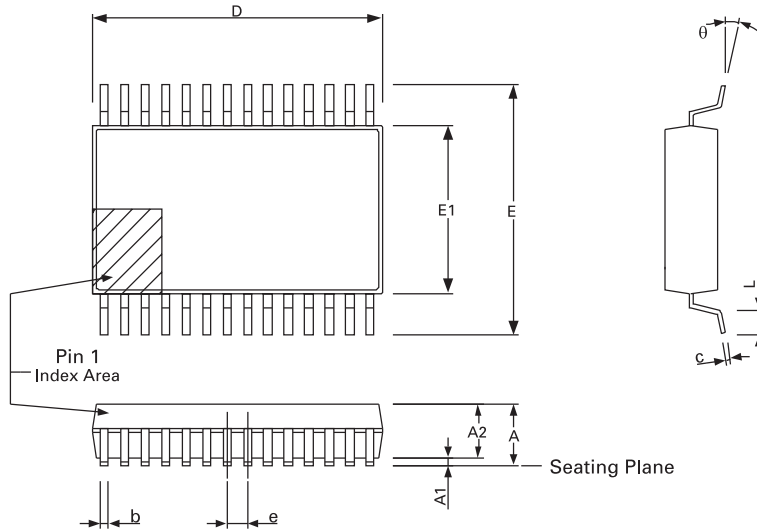

	MILLIMETRES	
	MIN.	MAX.
A	1.70	2.00
A1	0.05	0.15
A2	1.65	1.85
D	9.90	10.50
E	7.40	8.20
E1	5.00	5.60
L	0.55	0.95
e	0.65 BSC	
b	0.22	0.38
c	0.09	0.25

Comforms to JEDEC MO-187 VARIATION BA

ORDERING INFORMATION

DEVICE	PART MARKING
ZXCW6100S28	Zetex Acoustar™ ZXCW6100

© Zetex plc 2002

Europe		Americas	Asia Pacific
Zetex plc Fields New Road Chadderton Oldham, OL9 8NP United Kingdom Telephone: (44) 161 622 4422 Fax: (44) 161 622 4420 uk.sales@zetex.com	Zetex GmbH Streitfeldstraße 19 D-81673 München Germany Telephone: (49) 89 45 49 49 0 Fax: (49) 89 45 49 49 49 europe.sales@zetex.com	Zetex Inc 700 Veterans Memorial Hwy Hauppauge, NY11788 USA Telephone: (631) 360 2222 Fax: (631) 360 8222 usa.sales@zetex.com	Zetex (Asia) Ltd 3701-04 Metroplaza, Tower 1 Hing Fong Road Kwai Fong Hong Kong Telephone: (852) 26100 611 Fax: (852) 24250 494 asia.sales@zetex.com

These offices are supported by agents and distributors in major countries world-wide.

This publication is issued to provide outline information only which (unless agreed by the Company in writing) may not be used, applied or reproduced for any purpose or form part of any order or contract or be regarded as a representation relating to the products or services concerned. The Company reserves the right to alter without notice the specification, design, price or conditions of supply of any product or service.

For the latest product information, log on to www.zetex.com



ISSUE 2 - FEBRUARY 2004